

THIS DRAWING IS SUPPLIED FOR INFORMATION ONLY. DESIGN FEATURES, SPECIFICATIONS AND PERFORMANCE DATA SHOWN HEREON ARE THE PROPERTY OF THE AMPHENOL CORPORATION. NO RIGHTS OF REPRODUCTION ARE IMPLIED. ALL DIMENSIONS ARE SUBJECT TO NORMAL MANUFACTURING VARIATIONS.

CUSTOMER DRAWING

REVISIONS					
REV#	ECN#	REVISION ACTION	REV.BY:	APPR.BY:	DATE
A	--	INITIAL RELEASE	Jack	James	03/12/2020
B	--	增加规格参数	Star	James	10/29/2020

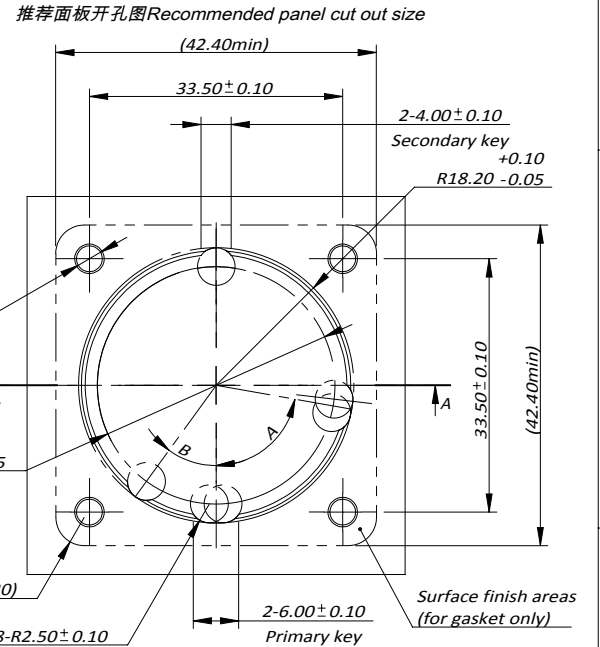
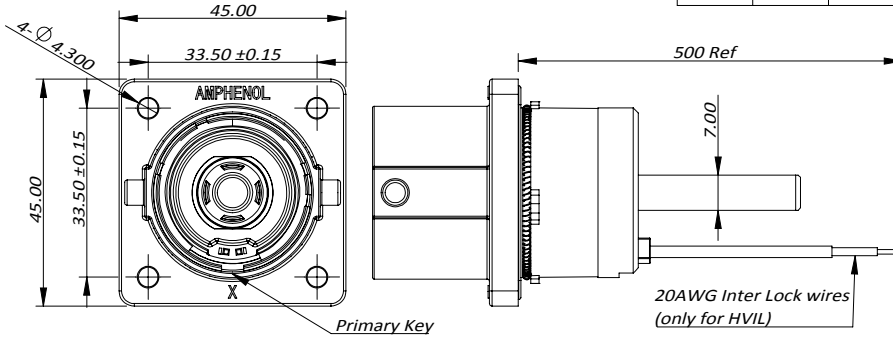
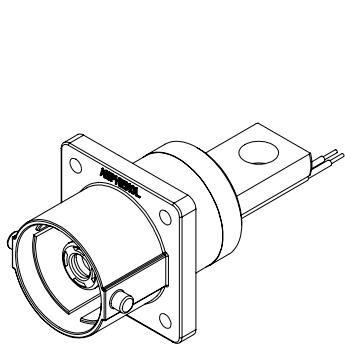

键位 Key	A	B
X	80°	36°
Y	50°	86°
U	36°	76°
V	100°	56°
W	130°	60°
T	144°	96°

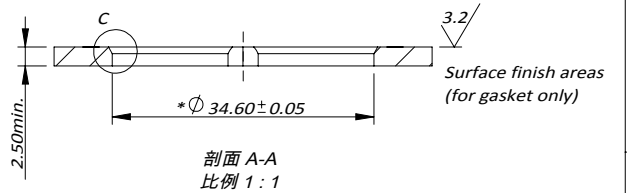
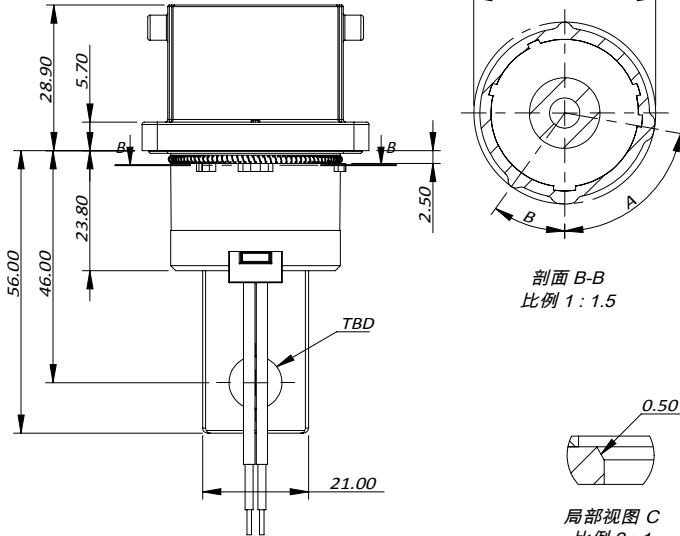

规格参数 (Spec.):

- 工作温度 Operating temperature: -40°C ~ +125°C.
- 带高压互锁 Electrical interlock (HVIL).
- 额定电流 Current rating:
Power: 500A; HVIL: 5A.
- 额定电压 Operating voltage:
Power: 1000 VDC; Signal: 60 VDC.
- 耐电压 Dielectric withstanding voltage:
A. 与插头对插后, Pin与铁壳之间
When mated, between pin and metal shell: 5000 VDC.
B. 与插头对插后, Pin与HVIL之间
When mated, between pin and HVIL: 5000 VDC.
C. 与插头对插后, HVIL与铁壳之间
When mated, between HVIL and metal shell: 500 VDC.
D. 与插头对插前, 两个HVIL端子之间耐压
Before mating, between two HVIL terminals: 500 VDC.
- 防护等级 Protection class: Mated-IP6k9k & IP67, unmated-IP2X.
- 电磁屏蔽 360° full Shielding.
- 机械寿命 Mating cycle: 100 Min.
- 绝缘材料满足 UL94V-0 Inner insulation material satisfy UL94V-0.
- 推荐法兰盘螺丝安装扭矩 Recommended Screw Assembly Torque on Flange: 1.6~2.4Nm
- 推荐铜排安装扭矩 Recommended Fasten Torque on Lug:
M8: 7.2~8.8Nm, M10: 17.1~20.9Nm
- 镀灰锌/镍合金, 符合RoHS, 满足500H中性盐雾实验
Gray Zinc/Nickel(ZnNi)Plating. RoHS compliant, Rated at 500hours salt spray.

订购信息 Ordering Information

PL 00 X -50X - 10X X -2

Key and Color	HVIL	Hole Type	Hole Size
"X", Orange	"0", NO HVIL	"D", Through Hole	
"Y", Black	"1", With HVIL	"M", Thread Hole	
"U", Yellow		"H", Slot Hole	
"V", Green			
"W", Red			
"T", Blue			





Amphenol Technical Products International Asia.

第三角投影 THIRD ANGLE PROJECTION	页面 SHEET	幅面 SIZE	版次 REV.	比例 SCALE	PART NAME:
	1 OF 2	A4	B		PwrLok 14mm G2 Rcpt Lug
签名 SIGNATURE	日期 DATE	UNLESS OTHERWISE SPECIFIED 1) All dimensions are in metric (mm). 2) Tolerances are as follows: 1.PL DEC ± 1.00 2.PL DEC ± 0.50 3.PL DEC ± 0.20			DWG NO:
制图 DRAWN	Star	10/29/2020	Angles ±1°		PL00X-50X-10XX-2
审核 CHECKED					CUST PART #
批准 APPROVAL					CUST REV.

THIS DRAWING IS SUPPLIED FOR INFORMATION ONLY. DESIGN FEATURES, SPECIFICATIONS AND PERFORMANCE DATA SHOWN HEREON ARE THE PROPERTY OF THE AMPHENOL CORPORATION. NO RIGHTS OF REPRODUCTION ARE IMPLIED. ALL DIMENSIONS ARE SUBJECT TO NORMAL MANUFACTURING VARIATIONS.

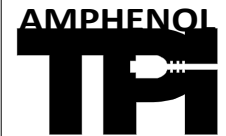
1	2	3	4	5	6	7	8	
A	Model No. 型号	AC P/N 料号	REVISIONS					
	PL00X-500-10M8-2	AC-HA011160	REV#	ECN#	REVISION ACTION	REV.BY:	APPR.BY:	DATE
	PL00Y-500-10M8-2	AC-HA011161	A	--	INITIAL RELEASE	Jack	James	03/12/2020
	PL00U-500-10M8-2	AC-HA011162	B	--	增加规格参数	Star	James	10/29/2020
	PL00V-500-10M8-2	AC-HA011163						
	PL00W-500-10M8-2	AC-HA011164						
	PL00X-500-10M10-2	AC-HA011165						
	PL00Y-500-10M10-2	AC-HA011166						
	PL00U-500-10M10-2	AC-HA011167						
	PL00V-500-10M10-2	AC-HA011168						
	PL00W-500-10M10-2	AC-HA011169						
	PL00X-500-10D8-2	AC-HA011170						
	PL00Y-500-10D8-2	AC-HA011171						
	PL00U-500-10D8-2	AC-HA011172						
	PL00V-500-10D8-2	AC-HA011173						
	PL00W-500-10D8-2	AC-HA011174						
	PL00X-500-10D10-2	AC-HA011175						
	PL00Y-500-10D10-2	AC-HA011176						
	PL00U-500-10D10-2	AC-HA011177						
	PL00V-500-10D10-2	AC-HA011178						
	PL00W-500-10D10-2	AC-HA011179						
	PL00X-501-10M8-2	AC-HA011180						
	PL00Y-501-10M8-2	AC-HA011181						
	PL00U-501-10M8-2	AC-HA011182						
	PL00V-501-10M8-2	AC-HA011183						
	PL00W-501-10M8-2	AC-HA011184						
	PL00X-501-10M10-2	AC-HA011185						
	PL00Y-501-10M10-2	AC-HA011186						
	PL00U-501-10M10-2	AC-HA011187						
	PL00V-501-10M10-2	AC-HA011188						
	PL00W-501-10M10-2	AC-HA011189						
	PL00X-501-10D8-2	AC-HA011190						
	PL00Y-501-10D8-2	AC-HA011191						
	PL00U-501-10D8-2	AC-HA011192						
	PL00V-501-10D8-2	AC-HA011193						
	PL00W-501-10D8-2	AC-HA011194						
	PL00X-501-10D10-2	AC-HA011195						
	PL00Y-501-10D10-2	AC-HA011196						
	PL00U-501-10D10-2	AC-HA011197						
	PL00V-501-10D10-2	AC-HA011198						
	PL00W-501-10D10-2	AC-HA011199						
	PL00T-500-10D8-2	AC-HA011969						
	PL00T-500-10M8-2	AC-HA011970						
	PL00T-500-10M10-2	AC-HA011971						
	PL00T-500-10D10-2	AC-HA011972						
	PL00T-501-10D8-2	AC-HA011973						
	PL00T-501-10M8-2	AC-HA011974						
	PL00T-501-10M10-2	AC-HA011975						
	PL00T-501-10D10-2	AC-HA011976						

	Amphenol Technical Products International Asia.						PART NAME: PwrLok 14mm G2 Rcpt Lug
	第三角投影 THIRD ANGLE PROJECTION	页面 SHEET	幅面 SIZE	版次 REV.	比例 SCALE		
		2 OF 2	A4	B			
签名 SIGNATURE	日期 DATE	UNLESS OTHERWISE SPECIFIED 1) All dimensions are in metric(mm). 2) Tolerances are as follows: 1.PL DEC ± 1.00 2.PL DEC ± 0.50 3.PL DEC ± 0.20			DWG NO: PL00X-50X-10XX-2		CUST REV.
制图 DRAWN	Star	10/29/2020			CUST PART #		
审核 CHECKED							
批准 APPROVAL							