

# Easy9

Affordable circuit protection  
you can depend on





Schneider Electric is a global specialist in energy management. Established as a circuit breaker designer and manufacturer in France since 1920, Schneider Electric are the worldwide leader of electrical protection technologies, present in more than 100 countries.

# Easy9

Affordable circuit protection  
you can depend on

## Contents

### Introduction

A complete range of modular devices.....p.4

New Easy9 circuit protection provides long-lasting protection.....p.6

### Product information

Insulated enclosures .....p.10

Metal enclosures .....p.11

Switch-disconnectors.....p.12

RCCB residual current circuit breakers .....p.13

Miniature circuit breaker .....p.14

RCBO residual current devices .....p.15

Product selector .....p.16

### Technical

Technical information .....p.18

# Easy9

Affordable circuit protection  
you can depend on

## A complete range of modular devices



Just what you need from circuit protection

We work closely with electricians worldwide to help bring safe electricity to homes and buildings around the globe. Now you can take pride in delivering to your customers the enhanced safety and peace of mind they deserve.

---

*“I would recommend Easy9 to anyone”*



New, robust circuit protection from a brand you trust

The new Easy9 range better supports your business as an electrician, helping you to be more effective through:

- > A high-quality, user-friendly design
- > Availability when and where you need it
- > Reliability you can count on



# Easy9

Affordable circuit protection  
you can depend on

## New Easy9 circuit protection provides long-lasting protection

Easy9 brings you the quality, peace of mind, and reliability of a high-end device at a mid-range price. Thanks to consistent design and high manufacturing standards, Easy9 is a durable range you can be proud to install.

- > Guaranteed compliance to product standards
- > Certification by independent authorities

Since  
**1920**

Leader in electrical  
switchgear





## Quality

- **100% designed and manufactured** by Schneider Electric
- All sites with **ISO 9000 certification**
- **Brand selected everywhere** for industry, hospitals and airports



## Availability

- **Always available** at your distributor
- **Complete coverage** of protection features
- **Large assortment** of ratings



## Customer satisfaction

- **Highly reliable and safe** circuit protection
- **Dependable** power supply



## Safety

- **Protection from** electric shocks, overloads and short circuits
- **Compliance to standards**



## Time saving

- **Consistent design** and connection features
- **One-stop shopping** for all parts
- **Proven robustness** to withstand wear and tear

# Easy9

Affordable circuit protection  
you can depend on

Schneider Electric warranty

Comprehensive range

Full compliance  
with international  
IEC standards 3rd  
party certification

Installer-friendly wiring  
with only 1 screwdriver





Class II front face

Full range coherence

Clear and visible production information. Whatever the toggle position

Full trip indication on the front panel by position of handle  
On-Off engraved

Neutral terminal identification engraved

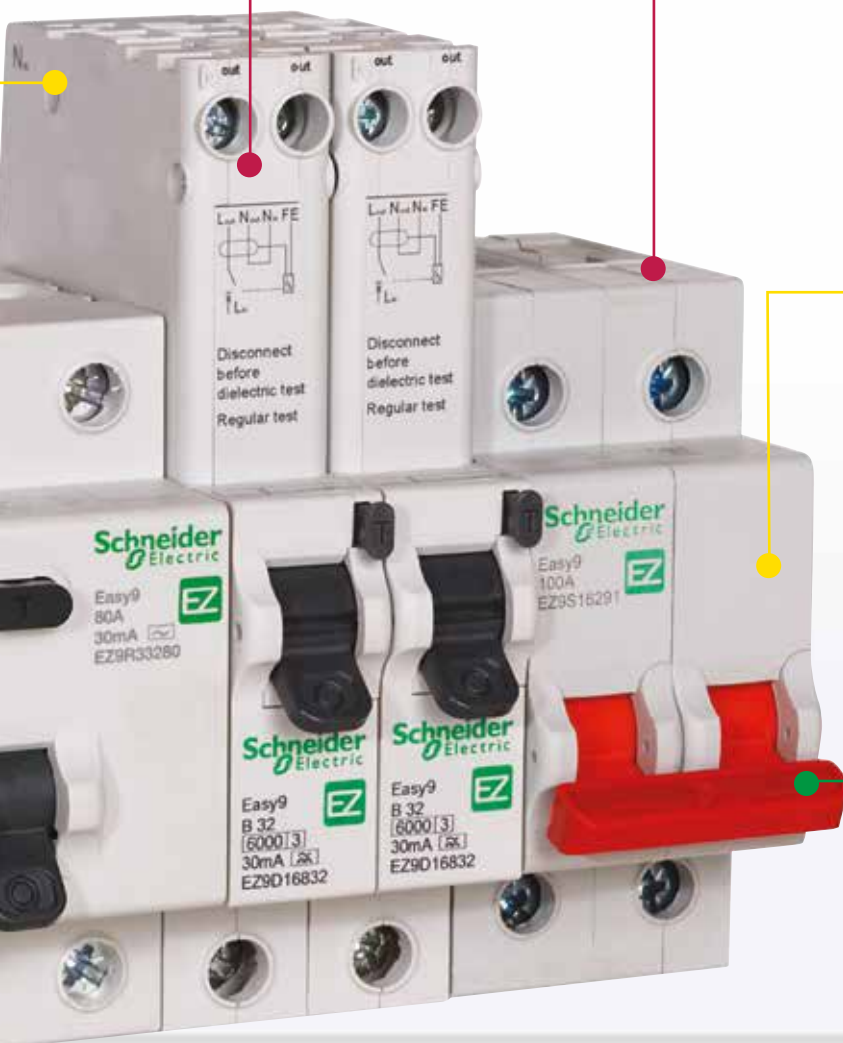

## Description

The surface mounting enclosure consists of:

- Surface mounting enclosure with:
- Multiple cable entry points and rear knock out slots
- Fixing holes with level adjustment
- Secure fixed DIN rail
- Earth terminal block and a neutral terminal blocks fitted as standard
- Secure busbar shield
- Configurable on site
- Options for smoked transparent door
- Standard consumer units up to 20 ways
- Enclosure colour: White RAL 9003



| Insulated Consumer Unit | Smoked Front Consumer Unit |                          |         |
|-------------------------|----------------------------|--------------------------|---------|
| Reference               | Reference                  | Description              | No Ways |
| EZ92CU                  |                            | 2 way EZ9 Consumer unit  | 2       |
| EZ94CU                  | EZ94SGCU                   | 4 way EZ9 Consumer unit  | 4       |
| EZ96CU                  | EZ96SGCU                   | 6 way EZ9 Consumer unit  | 6       |
| EZ98CU                  | EZ98SGCU                   | 8 way EZ9 Consumer unit  | 8       |
| EZ912CU                 |                            | 12 way EZ9 Consumer unit | 12      |
| EZ916CU                 |                            | 16 way EZ9 Consumer unit | 16      |
| EZ920CU                 |                            | 20 way EZ9 Consumer unit | 20      |

## Consumer units with switch/RCD's fitted

| Reference     | Description                         |
|---------------|-------------------------------------|
| EZ9R4R4CU     | 4+4W EZ9 CU 100A Sw, 63A RCCB X 2   |
| EZ9R6R6CU     | 6+6W EZ9 CU 100A Sw, 63A RCCB X 2   |
| EZ9R6R6DCU    | 6+6W EZ9 CU 100A Sw, 80A RCCB X 2   |
| EZ9R8R8DCU    | 8+8W EZ9 CU 100A Sw, 80A RCCB X 2   |
| EZ9S2R5R5DCU  | 2+5+5W EZ9 CU 100A Sw, 80A RCCB X 2 |
| EZ9S2R7R7DCU  | 2+7+7W EZ9 CU 100A Sw, 80A RCCB X 2 |
| Smoked front  |                                     |
| EZ9S2R5R5SGCU | 2+5+5W EZ9 100A Sw, 80A RCCB X 2    |
| EZ9S2R7R7SGCU | 2+7+7W EZ9 100A Sw, 80A RCCB X 2    |

## Flexible Split Load Boards

| Reference | Description                   | Max No of Ways Per Split | Total No Ways |
|-----------|-------------------------------|--------------------------|---------------|
| EZ9FS12CU | EZ9 Flexible split load board | 4/7/7                    | 12            |
| EZ9FS16CU | EZ9 Flexible split load board | 4/9/9                    | 16            |

## Shower / Garage units

| Reference     | Description                  | No Ways   |
|---------------|------------------------------|---|
| EZ9SHOWER6340 | 63A CU including 40A MCB     | 2 way enclosure + 63A 30mA RCCB and 40A MCB<br>Electric shower supply                 |
| EZ9SHOWER6345 | 63A CU including 50A MCB     | 2 way enclosure + 63A 30mA RCCB and 50A MCB<br>Electric shower supply                 |
| EZ9GARAGE63   | 63A CU including 6 & 16A MCB | 2 way IP55 enclosure + 63A 30mA RCD, 6A and 16A MCB<br>Electricity supply to a garage |

## Description

The surface mounting enclosure consists of:

- Metal surface mounting enclosure with:
- Multiple cable entry points and rear knock out slots
- Secure fixed DIN rail
- Earth terminal block and a neutral terminal blocks fitted as standard
- Secure busbar shield
- Standard consumer units up to 16 ways
- Enclosure colour: White RAL 9003.



## Metal Consumer Unit

| Reference       | Description                    | No Ways |
|-----------------|--------------------------------|---------|
| <b>EZ92MCU</b>  | 2 Way Metal EZ9 Consumer Unit  | 2       |
| <b>EZ94MCU</b>  | 4 Way Metal EZ9 Consumer Unit  | 4       |
| <b>EZ96MCU</b>  | 6 Way Metal EZ9 Consumer Unit  | 6       |
| <b>EZ98MCU</b>  | 8 Way Metal EZ9 Consumer Unit  | 8       |
| <b>EZ912MCU</b> | 12 Way Metal EZ9 Consumer Unit | 12      |
| <b>EZ916MCU</b> | 16 Way Metal EZ9 Consumer Unit | 16      |

## Functions

The switch-disconnectors are used for:

- Control (opening and closing of circuits under load).
- Disconnection of on-load electrical circuits already protected against overloads and short-circuits.



## 2P

### Easy9 control switches

| Rating (Ie)           |                  |
|-----------------------|------------------|
| 63 A                  | <b>EZ9S16263</b> |
| 100 A                 | <b>EZ9S16291</b> |
| Voltage rating (Ue)   | 400 V, 50/60 Hz  |
| Width in 9-mm modules | 4                |

## Certified compliant BSEN60947-3

### Connection

6.5 mm

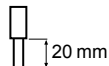

#### Rigid copper cables

≤ 50 mm<sup>2</sup> Tightening torque: 3.5 Nm

#### Flexible copper cables

≤ 35 mm<sup>2</sup> Tightening torque: 3.5 Nm

## Functions

- Tripping in case of leakage current only.
- One RCCB protects several circuits when fitted upstream of a group of circuit breakers.



## 2P

| Residual current circuit breakers AC |                       |
|--------------------------------------|-----------------------|
| Rating (In)                          | 30 mA                 |
| 63 A                                 | EZ9R33263             |
| 80 A                                 | EZ9R33280             |
| Voltage rating (Ue)                  | 127 - 230 V, 50/60 Hz |
| Width in 9-mm modules                | 4                     |

## Certified compliant BSEN61008-1

### Additional feature

|   |                |                           |
|---|----------------|---------------------------|
| Endurance (O-C)                                   | Electrical     | 2000 cycles               |
|   | Mechanical     | 5000 cycles               |
| Conditional rated short circuit current (Inc/IΔc) | With fuse      | 3000 A                    |
|   | With Easy9 MCB | 3000 A                    |
| Operating temperature                             |                | -5°C to +60°C             |
| Storage temperature                               |                | -40°C to +85°C            |
| Electrical feeding                                |                | By the top and the bottom |

## Connection

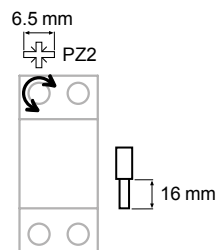

### Rigid copper cables

1 to 35 mm<sup>2</sup>      Tightening torque: 3.5 Nm

### Flexible copper cables

1 to 25 mm<sup>2</sup>      Tightening torque: 3.5 Nm



## 1P

### Circuit breakers

| Rating (In)           | Curve B   | Curve C   |
|-----------------------|-----------|-----------|
| 3 A                   | EZ9F16103 | -         |
| 6 A                   | EZ9F16106 | EZ9F66106 |
| 10 A                  | EZ9F16110 | EZ9F66110 |
| 16 A                  | EZ9F16116 | EZ9F66116 |
| 20 A                  | EZ9F16120 | EZ9F66120 |
| 25 A                  | EZ9F16125 | -         |
| 32 A                  | EZ9F16132 | EZ9F66132 |
| 40 A                  | EZ9F16140 | EZ9F66140 |
| 50 A                  | EZ9F16150 | EZ9F66150 |
| Width in 9-mm modules | 2         |           |

## Certified compliant BS EN 60898-1

### Additional feature

#### According to EN 60898-1

##### Breaking capacity (Icn)

|      |          |        |
|------|----------|--------|
| Ph/N | 230 V AC | 6000 A |
|------|----------|--------|

##### Additional characteristics

|                       |            |                |
|-----------------------|------------|----------------|
| Endurance (O-C)       | Electrical | 4,000 cycles   |
|                       | Mechanical | 10,000 cycles  |
| Operating temperature |            | -5°C to +60°C  |
| Storage temperature   |            | -40°C to +85°C |

### Connection

6.5 mm



PZ2



16 mm

#### Rigid copper cables

3 to 25 A 1 to 25 mm<sup>2</sup> Tightening torque: 2 Nm

32 to 50 A 1 to 35 mm<sup>2</sup> Tightening torque: 3.5 Nm

#### Flexible copper cables

3 to 25 A 1 to 16 mm<sup>2</sup> Tightening torque: 2 Nm

32 to 50 A 1 to 25 mm<sup>2</sup> Tightening torque: 3.5 Nm

## Functions

- Protection from short-circuits.
- Protection of cable from overloads.
- Protection of persons from electric shocks by direct contact (30 mA sensitivity)
- Can be fitted instead of a miniature circuit breaker for complete protection of one circuit.

The Earth Reference Cable "FE": enables RCD to protect users from electric shocks, even in case of supply neutral loss, neutral conductor breakage or supply voltage drop (FE= Functional Earth).

## 1P+N



| Easy9 RCBO type A  30 mA |                 |
|---|-----------------|
| Rating (In)   | B curve         |
| 6 A   | EZ9D16806       |
| 10 A  | EZ9D16810       |
| 16 A  | EZ9D16816       |
| 20 A  | EZ9D16820       |
| 25 A  | EZ9D16825       |
| 32 A  | EZ9D16832       |
| 40 A  | EZ9D16840       |
| 50 A  | EZ9D16850       |
| Voltage rating (Ue)   | 230 V AC, 50 Hz |
| Width in 9-mm modules   | 2               |

## Certified compliant BS EN 61009-1

### Connection

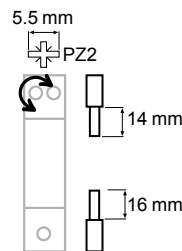

#### Rigid copper cables

|             |                         |                         |
|-------------|-------------------------|-------------------------|
| L in        | 1 to 25 mm <sup>2</sup> | Tightening torque: 2 Nm |
| L and N out | 1 to 16 mm <sup>2</sup> | Tightening torque: 2 Nm |

#### Flexible copper cables

|             |                         |                         |
|-------------|-------------------------|-------------------------|
| L in        | 1 to 16 mm <sup>2</sup> | Tightening torque: 2 Nm |
| L and N out | 1 to 10 mm <sup>2</sup> | Tightening torque: 2 Nm |

| Insulated Consumer Unit | Smoked front Consumer Unit | Metal Consumer Unit |                          |         |
|-------------------------|----------------------------|---------------------|--------------------------|---------|
| Reference               | Reference                  | Reference           | Description              | No Ways |
| EZ92CU                  |                            | EZ92MCU             | 2 Way EZ9 Consumer unit  | 2       |
| EZ94CU                  | EZ94SGCU                   | EZ94MCU             | 4 Way EZ9 Consumer unit  | 4       |
| EZ96CU                  | EZ96SGCU                   | EZ96MCU             | 6 Way EZ9 Consumer unit  | 6       |
| EZ98CU                  | EZ98SGCU                   | EZ98MCU             | 8 Way EZ9 Consumer unit  | 8       |
| EZ912CU                 |                            | EZ912MCU            | 12 Way EZ9 Consumer unit | 12      |
| EZ916CU                 |                            | EZ916MCU            | 16 Way EZ9 Consumer unit | 16      |
| EZ920CU                 |                            |                     | 20 Way EZ9 Consumer unit | 20      |



### Incoming Devices

| Reference | Device | Rating    | Description  |
|-----------|--------|-----------|--|
| EZ9S16263 | Switch | 63A       | EZ9 Switch Disconnecter 2P 63A 400V                                |
| EZ9S16291 | Switch | 100A      | EZ9 Switch Disconnecter 2P 100A 400V                               |
| EZ9R33263 | RCCB   | 63A, 30mA | EZ9 RCCB 2P 63A 30mA AC-type 230V Residual Current Circuit Breaker |
| EZ9R33280 | RCCB   | 80A, 30mA | EZ9 RCCB 2P 80A 30mA AC-type 230V Residual Current Circuit Breaker |

### For split load applications select a split load kit

| Reference    | Description     | Rating   |
|--------------|-----------------|----------|
| EZ963R30KIT2 | RCCB and cables | 63A 30mA |
| EZ980R30KIT2 | RCCB and cables | 80A 30mA |

or

### Select consumer units with switch/RCD's fitted

| Reference   | Description                         | Un/P Ways | RCD1 ways | RCD2 ways |
|---|-------------------------------------|-----------|-----------|-----------|
| <b>Split boards with dual RCD's</b>                       |                                     |           |           |           |
| EZ9R4R4CU   | 4+4W EZ9 CU 100A Sw, 63A RCCB X 2   |           | 4         | 4         |
| EZ9R6R6CU   | 6+6W EZ9 CU 100A Sw, 63A RCCB X 2   |           | 6         | 6         |
| EZ9R6R6DCU  | 6+6W EZ9 CU 100A Sw, 80A RCCB X 2   |           | 6         | 6         |
| EZ9R8R8DCU  | 8+8W EZ9 CU 100A Sw, 80A RCCB X 2   |           | 8         | 8         |
| <b>High integrity boards with dual RCD's</b>              |                                     |           |           |           |
| EZ9S2R5R5DCU  | 2+5+5W EZ9 CU 100A Sw, 80A RCCB X 2 | 2         | 5         | 5         |
| EZ9S2R7R7DCU  | 2+7+7W EZ9 CU 100A Sw, 80A RCCB X 2 | 2         | 7         | 7         |
| <b>Smoked front high integrity boards with dual RCD's</b> |                                     |           |           |           |
| EZ9S2R5R5SGCU   | 2+5+5W EZ9 CU 100A Sw, 80A RCCB X 2 | 2         | 5         | 5         |
| EZ9S2R7R7SGCU   | 2+7+7W EZ9 CU 100A Sw, 80A RCCB X 2 | 2         | 7         | 7         |
| <b>Metal Split boards with dual RCD's</b>                 |                                     |           |           |           |
| EZ9R4R4MCU  | 4+4W EZ9 CU 100A Sw, 63A RCCB X 2   |           | 4         | 4         |
| EZ9R6R6DMCU   | 6+6W EZ9 CU 100A Sw, 80A RCCB X 2   |           | 6         | 6         |
| <b>Metal High integrity boards with dual RCD's</b>        |                                     |           |           |           |
| EZ9S2R5R5DMCU   | 2+5+5W EZ9 CU 100A Sw, 80A RCCB X 2 | 2         | 5         | 5         |





Select outgoing devices or accessories

### SP 6kA MCBs (B curve)

| Reference | Description   | Current Rating |
|-----------|---------------|----------------|
| EZ9F16103 | MCB (B curve) | 3A             |
| EZ9F16106 | MCB (B curve) | 6A             |
| EZ9F16110 | MCB (B curve) | 10A            |
| EZ9F16116 | MCB (B curve) | 16A            |
| EZ9F16120 | MCB (B curve) | 20A            |
| EZ9F16125 | MCB (B curve) | 25A            |
| EZ9F16132 | MCB (B curve) | 32A            |
| EZ9F16140 | MCB (B curve) | 40A            |
| EZ9F16150 | MCB (B curve) | 50A            |

### SP 6kA MCBs (C curve)

| Reference | Description   | Current Rating |
|-----------|---------------|----------------|
| EZ9F66106 | MCB (C curve) | 6A             |
| EZ9F66110 | MCB (C curve) | 10A            |
| EZ9F66116 | MCB (C curve) | 16A            |
| EZ9F66120 | MCB (C curve) | 20A            |
| EZ9F66132 | MCB (C curve) | 32A            |
| EZ9F66140 | MCB (C curve) | 40A            |
| EZ9F66150 | MCB (C curve) | 50A            |

### SP 6kA 1 module RCBO (B curve)

| Reference | Description             | Current rating |
|-----------|-------------------------|----------------|
| EZ9D16806 | RCBO 30mA 1 Module 1P&N | 6A             |
| EZ9D16810 | RCBO 30mA 1 Module 1P&N | 10A            |
| EZ9D16816 | RCBO 30mA 1 Module 1P&N | 16A            |
| EZ9D16820 | RCBO 30mA 1 Module 1P&N | 20A            |
| EZ9D16825 | RCBO 30mA 1 Module 1P&N | 25A            |
| EZ9D16832 | RCBO 30mA 1 Module 1P&N | 32A            |
| EZ9D16840 | RCBO 30mA 1 Module 1P&N | 40A            |
| EZ9D16850 | RCBO 30mA 1 Module 1P&N | 50A            |

### Accessories

| Reference   | Description   |
|-------------|---|
| EZ9LKIT     | Door lock kit (for metal enclosure only)                              |
| EZ9EARTHKIT | Additional earth terminals for clean earth or high integrity earthing |
| EZ916BKIT   | Replacement/spare main busbar   |
| SEDNBP      | Blanking plate  |

# Technical information



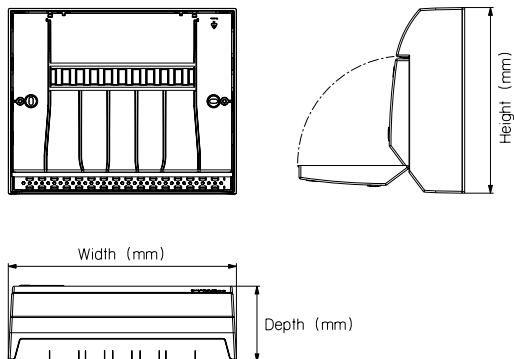

### Insulated Units

| Ref No.       | No Ways | Height (mm) | Width (mm) | Depth (mm) |
|---------------|---------|-------------|------------|------------|
| EZ92CU        | 2       | 240         | 189        | 127        |
| EZ94CU        | 4       | 240         | 224        | 127        |
| EZ96CU        | 6       | 240         | 260        | 127        |
| EZ98CU        | 8       | 240         | 296        | 127        |
| EZ912CU       | 12      | 240         | 368        | 127        |
| EZ916CU       | 16      | 240         | 440        | 127        |
| EZ920CU       | 20      | 240         | 510        | 127        |
| EZ9R4R4CU     | 8       | 240         | 368        | 127        |
| EZ9R6R6CU     | 12      | 240         | 440        | 127        |
| EZ9R6R6DCU    | 12      | 240         | 440        | 127        |
| EZ9S2R5R5DCU  | 12      | 240         | 440        | 127        |
| EZ9R8R8DCU    | 16      | 240         | 510        | 127        |
| EZ9S2R7R7DCU  | 16      | 240         | 510        | 127        |
| EZ94SGCU      | 4       | 240         | 224        | 127        |
| EZ96SGCU      | 6       | 240         | 260        | 127        |
| EZ98SGCU      | 8       | 240         | 296        | 127        |
| EZ9S2R5R5SGCU | 12      | 240         | 440        | 127        |
| EZ9S2R7R7SGCU | 16      | 240         | 510        | 127        |
| EZ9FS12CU     | 12      | 240         | 440        | 127        |
| EZ9FS16CU     | 16      | 240         | 510        | 127        |

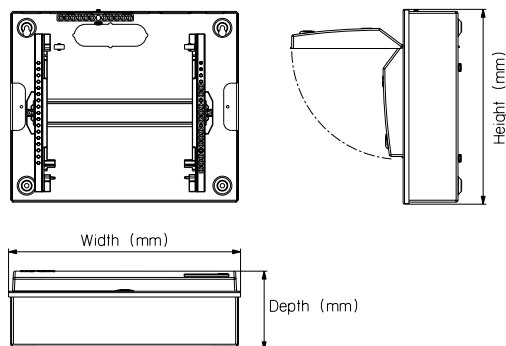

### Metal Units

| Ref No.       | No Ways | Height (mm) | Width (mm) | Depth (mm) |
|---------------|---------|-------------|------------|------------|
| EZ92MCU       | 2       | 247         | 186        | 111        |
| EZ94MCU       | 4       | 247         | 222        | 111        |
| EZ96MCU       | 6       | 247         | 258        | 111        |
| EZ98MCU       | 8       | 247         | 294        | 111        |
| EZ912MCU      | 12      | 247         | 366        | 111        |
| EZ916MCU      | 16      | 247         | 438        | 111        |
| EZ9R4R4MCU    | 8       | 247         | 366        | 111        |
| EZ9R6R6DMCU   | 12      | 247         | 438        | 111        |
| EZ9S2R5R5DMCU | 12      | 247         | 438        | 111        |

Note: Incoming and outgoing devices must be selected separately from the devices section -

only applies to EZ9\*\*CU and EZ9\*\*MCU

Incoming devices available

- Switch disconnecter 63A & 100A

- RCCB's 63A/30mA 80A/30mA

Max. busbar splits - for split load

8 way 2+4 to 4+2

12 way 4+6 to 6+4

16 way 6+8 to 8+6

### Technical data

Max. busbar current (A) 100A

Max. operating voltage 230/240V @ 50Hz

Max. cable capacity 25 mm<sup>2</sup> (earth and neutral bars)

**Certification BS EN 61439-3**



Position contact indication  
 Suitable for isolation according to BSEN 60947-3 standard  
 Manual control on front face by O-I lever

## Characteristics

### Main characteristics

|  |                 |
|--|-----------------|
| Operating category                                   | AC-22A          |
| Permissible rated short-time withstand current (Icw) | 12 Ie, 1 second |
| Conditional rated short-circuit current (Inc)        | 5000 A          |
| Rated short-circuit closing current (Icm)            | 15 Ie           |

### Additional characteristics

|                                  |   |                          |
|----------------------------------|---|--------------------------|
| Degree of protection (IEC 60529) | Device only                                     | IP20                     |
| Endurance (O-C)                  | Mechanical                                      | 40 -100 A<br>8500 cycles |
|                                  | Electrical                                      | 40-100 A<br>1500 cycles  |
| Operating temperature            | -5°C to +55°C                                   |                          |
| Storage temperature              | -5°C to +70°C                                   |                          |
| Tropicalisation (IEC 60068-1)    | Treatment 2<br>(relative humidity 95 % to 55°C) |                          |

## Dimensions (mm)

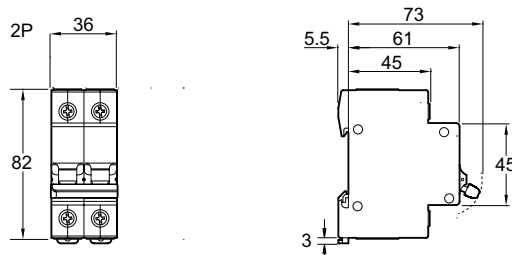

## Weight (g)

|      |                           |
|------|---------------------------|
| Type | Easy9 switch-disconnector |
| 2P   | 175                       |



**+** Positive contact indication.  
 Fault tripping indication on the front panel by the position of the handle (O - I engraved)

## Characteristics

### Main characteristics

|   |      |
|---|------|
| Rated impulse withstand voltage (U <sub>imp</sub> ) | 4 kV |
|---|------|

### According to IEC 61008-1

|   |       |
|---|-------|
| Making and breaking capacity (I <sub>m</sub> /I <sub>Δm</sub> ) | 500 A |
|---|-------|

### Additional characteristics

|                                  |  |      |
|----------------------------------|--|------|
| Degree of protection (IEC 60529) | Device only                                  | IP20 |
| Hazardous substances             | RoHS 2003 compliant                          |      |
| Tropicalisation (IEC 60068-1)    | Treatment 2 (relative humidity 95 % to 55°C) |      |

## Dimensions (mm)

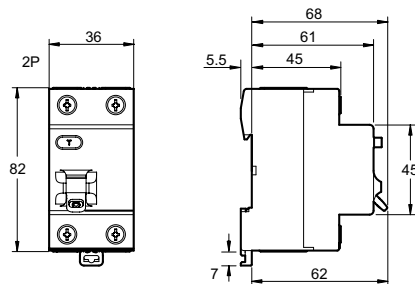

## Weight (g)

| Type | Easy9 RCCB |
|------|------------|
| 2P   | 195        |

Easy9 circuit breakers combine the following functions:



Circuit protection against short-circuit currents.

Circuit protection against overload currents.



Fault tripping indication on the front panel by the position of the handle (O - I engraved)

### Characteristics

#### Main characteristics

|                     |                       |
|---------------------|-----------------------|
| Voltage rating (Ue) | 230/400 V AC          |
| Operating frequency | 50/60 Hz              |
| Electrical feeding  | By the top and bottom |

#### Additional characteristics

|                                  |             |  |
|----------------------------------|-------------|--|
| Degree of protection (IEC 60529) | Device only | IP20   |
| Hazardous substances             |             | RoHS 2003 compliant                          |
| Tropicalisation (IEC 60068-1)    |             | Treatment 2 (relative humidity 95 % to 55°C) |

### Dimensions (mm)

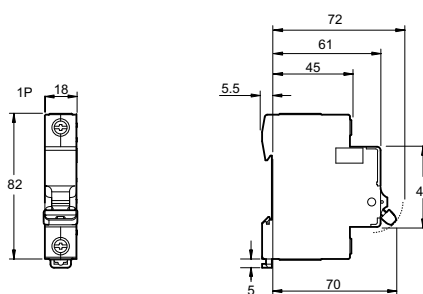

### Weight (g)

| Type | Easy9 MCB |
|------|-----------|
| 1P   | 100       |

## Certified compliant BS EN 61009-1

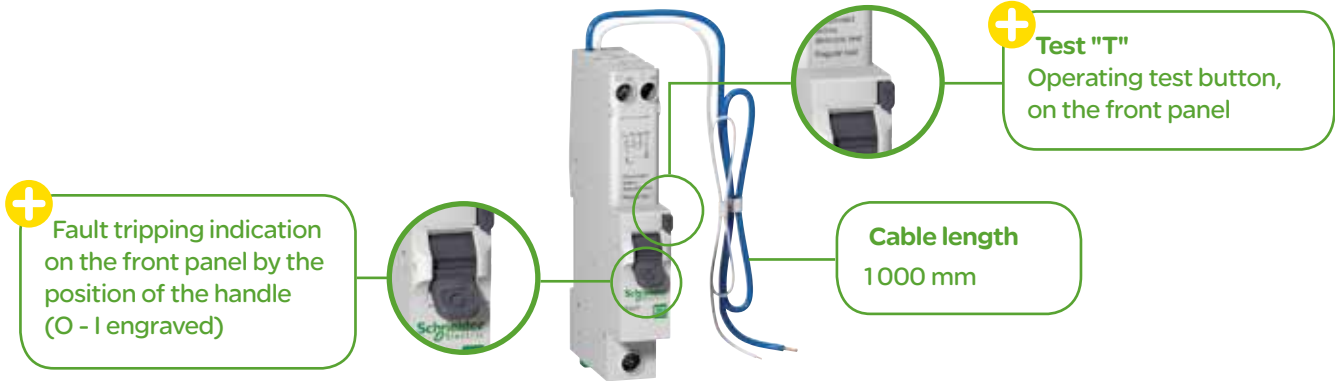

## Characteristics

### Main characteristics

|                 |            |              |
|-----------------|------------|--------------|
| Endurance (O-C) | Electrical | 4000 cycles  |
|                 | Mechanical | 10000 cycles |

### Additional characteristics

|                                  |             |  |
|----------------------------------|-------------|--|
| Degree of protection             | Device only | IP20   |
| Overvoltage category (IEC 60364) |             | IV   |
| Operating temperature            |             | -15°C to +60°C                               |
| Storage temperature              |             | -40°C to +85°C                               |
| Hazardous substances             |             | RoHS 2003 compliant                          |
| Tropicalisation (IEC 60068-1)    |             | Treatment 2 (relative humidity 95 % to 55°C) |

## Dimensions (mm)

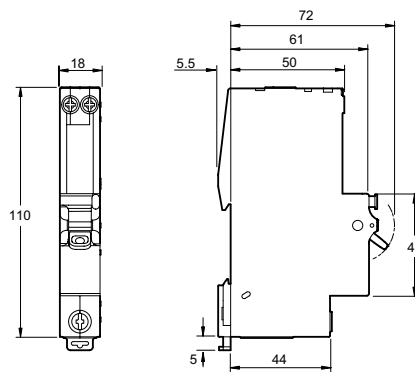







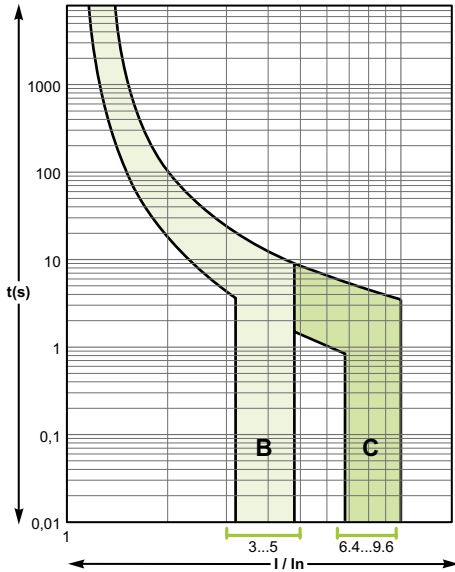



## Weight (g)

|             |                   |
|-------------|-------------------|
| <b>Type</b> | <b>Easy9 RCBO</b> |
| 1P+N        | 180               |

## Time current tripping curves



## MCB selection chart for household appliances

| Appliance  | Capacity   | MCB rating (A) | Tripping curves |
|--|------------|----------------|-----------------|
| Air conditioner<br>             | 1 ton      | 16             | "C"             |
|  | 1.5 ton    | 20             |                 |
|  | 2 ton      | 20             |                 |
|  | 3 ton      | 25             |                 |
| Refrigerator<br>                | 165 litres | 2              |                 |
|  | 285 litres | 2              |                 |
| Water heater<br>                | 1 kW       | 6              | "B"             |
|  | 3 kW       | 16             |                 |
| Electric kettle<br>             | 1.5 kW     | 10             |                 |
| Food processor (50 % load)<br> | 200 W      | 1              | "C"             |
| Vacuum cleaner<br>            | 50 W       | 0.5            |                 |
| Toaster<br>                   | 1.2 kW     | 6              | "B"             |
| Cooking range<br>             | 750 W      | 4              |                 |
|  | 2 kW       | 10             |                 |
|  | 4.5 kW     | 25             |                 |
| Room heater<br>               | 1 kW       | 6              |                 |
|  | 2 kW       | 10             |                 |
| Washing machine<br>           | 300 W      | 2              | "C"             |
|  | 1.3 kW     | 10             |                 |
| Electric iron<br>             | 750 W      | 6              | "B"             |
|  | 1.25 kW    | 6              |                 |



### Miniature circuit breakers

#### Function

- Protection from short-circuits.
- Protection of cable from overload.

#### Selection of circuit breakers according to the cables to be protected (BS 7671)

- PVC-insulated, copper, flexible or rigid cable.
- Ambient temperature:
  - 30°C in the open air (methods A, B, C, E)
  - 20°C if buried (method D),
- For other situations, refer to BS 7671 standard (or UK wiring regulations).

#### MCB current rating

#### Single-phase circuit

| Cable cross section (in mm <sup>2</sup> )  | 1.5   | 2.5 | 4  | 6  | 10 | 16 | 25 | 35  |     |
|--|---|-----|----|----|----|----|----|-----|-----|
| <b>Type of installation</b>  | <b>Maximum rating of the circuit breaker used there (in Ampere)</b> |     |    |    |    |    |    |     |     |
| <b>A: in conduit or directly in thermally insulated wall, moulding, architrave, window frame</b> |   |     |    |    |    |    |    |     |     |
| Single core  |   | 10  | 16 | 25 | 32 | 40 | 50 | 80  | 80  |
| Multicore  |   | 10  | 16 | 25 | 32 | 40 | 50 | 70  | 80  |
| <b>B: in conduit in a wall, in conduit trunking or cable duct on a wall, in building cavity</b>  |   |     |    |    |    |    |    |     |     |
| Single core  |   | 16  | 20 | 32 | 40 | 50 | 70 | 100 | 125 |
| Multicore  |   | 16  | 20 | 25 | 32 | 50 | 50 | 80  | 80  |
| <b>C: direct on a wall, suspended from ceilings, on unperforated cable tray, in masonry wall</b> |   |     |    |    |    |    |    |     |     |
| Single core or multicore   |   | 16  | 25 | 32 | 40 | 63 | 80 | 100 | 125 |
| <b>D: in conduit in the ground</b>   |   |     |    |    |    |    |    |     |     |
| Multicore or single core   |   | 20  | 25 | 32 | 40 | 50 | 70 | 80  | 80  |
| <b>D: directly in the ground</b>   |   |     |    |    |    |    |    |     |     |
| Multicore or single core   |   | 20  | 25 | 32 | 40 | 63 | 80 | 100 | 125 |
| <b>E: in free-air, on cable ladder, on perforated cable tray</b>                                 |   |     |    |    |    |    |    |     |     |
| Multicore  |   | 20  | 25 | 40 | 40 | 70 | 80 | 100 | 125 |



## Residual current devices

### Function

- Protection of persons against electric shock by direct contact (30 mA).
- Protection of installations against the risk of fire (300 mA).
- Protection of persons against electric shock by indirect contact (100 mA to 300 mA).

### Operating principle

Protection from electric shocks by direct contact:

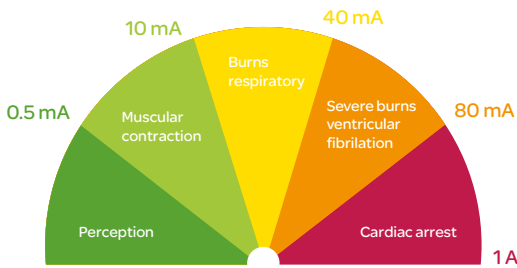

Research worldwide shows that the intensity of current flowing through the body determines the extent and severity of an electric shock.

- Injuries become serious when currents exceed 40 to 50 mA during one second.
- Theoretically, a 150 mA current flows through the body when a person touches a 230 V energised conductor under dry conditions.

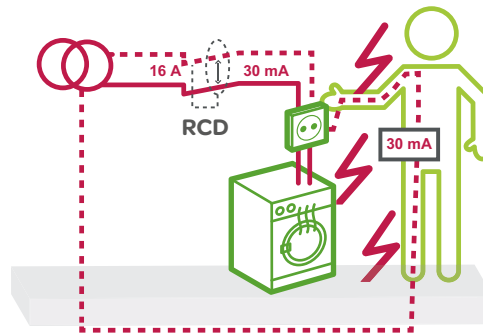

By measuring the intensity difference between live and neutral conductors, RCDs actually detect the current flowing through the human body. If this current reaches the 30 mA limit, the RCD trips within a few milliseconds, so preventing injury or worse.

### Check RCDs regularly



#### Test



! Testing the RCD every 3 months enables detection of any event that may have impaired its operation

### Selection

#### Residual current sensitivity

| Protection from   | Residential   | Non-residential  | Sensitivity  |
|---|---|--|--|
|  <p>Electric shocks by direct contact</p>  | <ul style="list-style-type: none"> <li>■ Mandatory protection for all socket outlets</li> <li>■ Mandatory protection for all electrical equipment in bathroom</li> <li>■ Recommended for lighting circuits</li> </ul> | <ul style="list-style-type: none"> <li>■ Mandatory protection for all socket outlets</li> <li>■ Mandatory protection for all equipment located                             <ul style="list-style-type: none"> <li>■ Close to water points</li> </ul> </li> </ul> | <ul style="list-style-type: none"> <li>■ 30 mA</li> <li>■ 10 mA for all applications where required by the standard (e.g.: jacuzzi, swimming pools, etc.)</li> </ul> |
|  <p>Fire ignited by leakage current</p>    | <ul style="list-style-type: none"> <li>■ Recommended in old buildings (presence of dust or moisture)</li> </ul>   | <ul style="list-style-type: none"> <li>■ Mandatory in all locations under risk of fire or explosion</li> <li>■ Recommended in all premises under presence of dust, moisture, chemical agents...</li> </ul>   | <ul style="list-style-type: none"> <li>■ 300 mA</li> </ul>   |
|  <p>Electric shock by indirect contact</p> | <ul style="list-style-type: none"> <li>■ All circuits in case of "TT" earthing system</li> </ul>  | <ul style="list-style-type: none"> <li>■ All circuits in case of "TT" earthing system</li> </ul>   | <ul style="list-style-type: none"> <li>■ 100 mA or 300 mA</li> </ul>   |



**Current rating:** shall not be in excess of upstream MCB current rating

#### Requirements from wiring regulation (411.3.3)

Protection by means of a residual current protective device (RCD), shall be provided for:

- Socket outlets with a rated current not exceeding 20 A, that are for ordinary persons and intended for general use, mobile equipment with a current rating not exceeding 32 A for use outdoors.
- In rooms containing a bath or a shower.

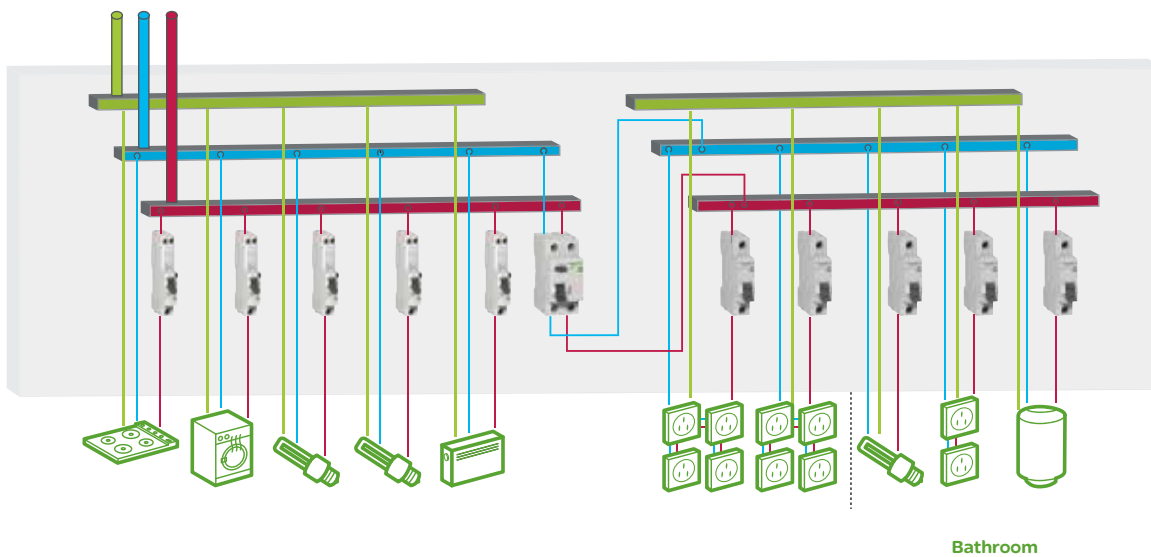



## UK contact details -

# 0870 608 8 608

Fax 0870 608 8 606

---

## Ireland contact details -

# 01 601 2200

Fax 01 601 2201

As a global specialist in energy management with operations in more than 100 countries, Schneider Electric offers integrated solutions across multiple market segments, including leadership positions in energy and infrastructure, industrial processes, building automation and data centres/networks, as well as a broad presence in residential applications.

Focused on making energy safe, reliable, efficient, productive and green, the company's 150,000 plus employees achieved sales of 24 billion euros in 2013, through an active commitment to help individuals and organisations Make the most of their energy<sup>SM</sup>.

We are changing our brand names and becoming one Schneider Electric. You'll get the same great quality products, but from one name you can remember and trust. This provides you and your customers with the reassurance associated with Schneider Electric.

Some of our market leading brands have already become Schneider Electric including **Merlin Gerin, Telemecanique, Square D, GET, Mita, Sarel, Himel, Thorsman, Tower and TAC.**

Working as one Schneider Electric makes it clearer that our ranges are highly compatible for integrated solutions.

## Schneider Electric Ltd

United Kingdom  
Stafford Park 5,  
Telford  
Shropshire  
TF3 3BL  
Tel: 0870 608 8 608  
Fax: 0870 608 8 606  
[www.schneider-electric.com/uk](http://www.schneider-electric.com/uk)

Ireland  
Head office,  
Block a  
Maynooth Business Campus  
Maynooth, Co. Kildare  
Tel: (01) 601 2200  
Fax: (01) 601 2201  
[www.schneider-electric.com/ie](http://www.schneider-electric.com/ie)

Schneider Electric Limited is a company registered in England and Wales.  
Registered number: 1407228. Registered office: Stafford Park 5, Telford, Shropshire TF3 3BL.

© 2014 Schneider Electric. All Rights Reserved. Schneider Electric, Active Energy Management, Compact, EcoStruxure, ION Enterprise, iRIO, Make the most of your energy, Masterpact, Micrologic, Power Plant To Plug, Modbus, and PowerLogic are owned by Schneider Electric Industries SAS, or its affiliated companies in the United States and other countries.

As standards, specifications and designs change from time to time, please ask for confirmation of the information given in this publication.

member of

