

## Specification

Part Number:	MCT046A12W800320LML		
Version:	1		
Date:	08/09/2016		
<b>Revision</b>			
VERSION	DATE	REVISED PAGE NO.	Note
0	2016/09/06		First issue



# Contents

1. Module Classification Information

2. Summary

3. General Specification

4. Interface

5. Contour Drawing

6. Block Diagram

7. Absolute Maximum Ratings

8. Electrical Characteristics

9. Interface Timing Characteristics

10. Optical Characteristics

11. Reliability

12. Other

MIDAS

design • manufacture • supply

## 2.Summary

This technical specification applies to 4.6' color TFT-LCD panel. The 4.6' color TFT-LCD panel is designed for camcorder, digital camera application and other electronic products which require high quality flat panel displays. This module follows RoHS.

MIDAS

design • manufacture • supply

### 3.General Specifications

- Size: 4.6 inch
- Dot Matrix: 800 x RGBx320(TFT) dots
- Module dimension: 120.7(W) x 56.16(H) x 3.1(D) mm
- Active area: 108 x 43.2 mm
- Dot pitch: 0.045(W)x 0.135(H) mm
- LCD type: TFT, Normally White, Transmissive
- View Direction: 12 o'clock
- Gray Scale Inversion Direction: 6 o'clock
- Backlight Type: LED, Normally White
- With /Without TP: Without TP
- Surface: Anti-Glare

\*Color tone slight changed by temperature and driving voltage.

design • manufacture • supply

## 4.Interface

### 4.1. LCM PIN Definition

No.	Symbol	Description
1	VLED-	Backlight LED Cathode
2	VLED+	Backlight LED Anode.
3	GND	System Ground
4	VDD	Power supply for logic operation
5~12	R0~R7	Data bus
13~20	G0~G7	Data bus
21~28	B0~B7	Data bus
29	GND	System Ground
30	DCLK	Pixel clock signal
31	DISP	Display on/off control
32	NC	No connect
33	NC	No connect
34	DE	Data Enable
35	NC	No connect
36	GND	System Ground
37	NC	No connect
38	NC	No connect
39	NC	No connect
40	NC	No connect

# 5. Contour Drawing

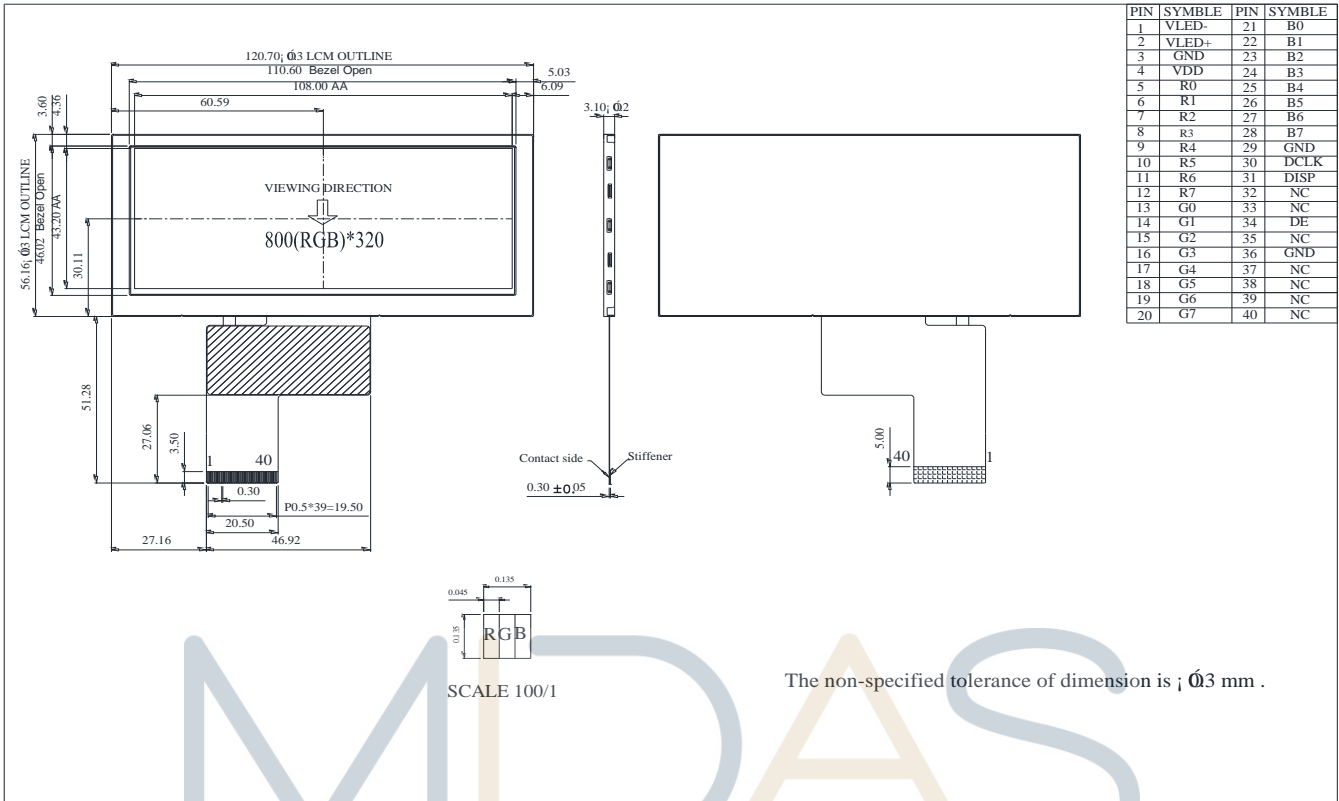

MIDAS

design • manufacture • supply

## 6. Block Diagram

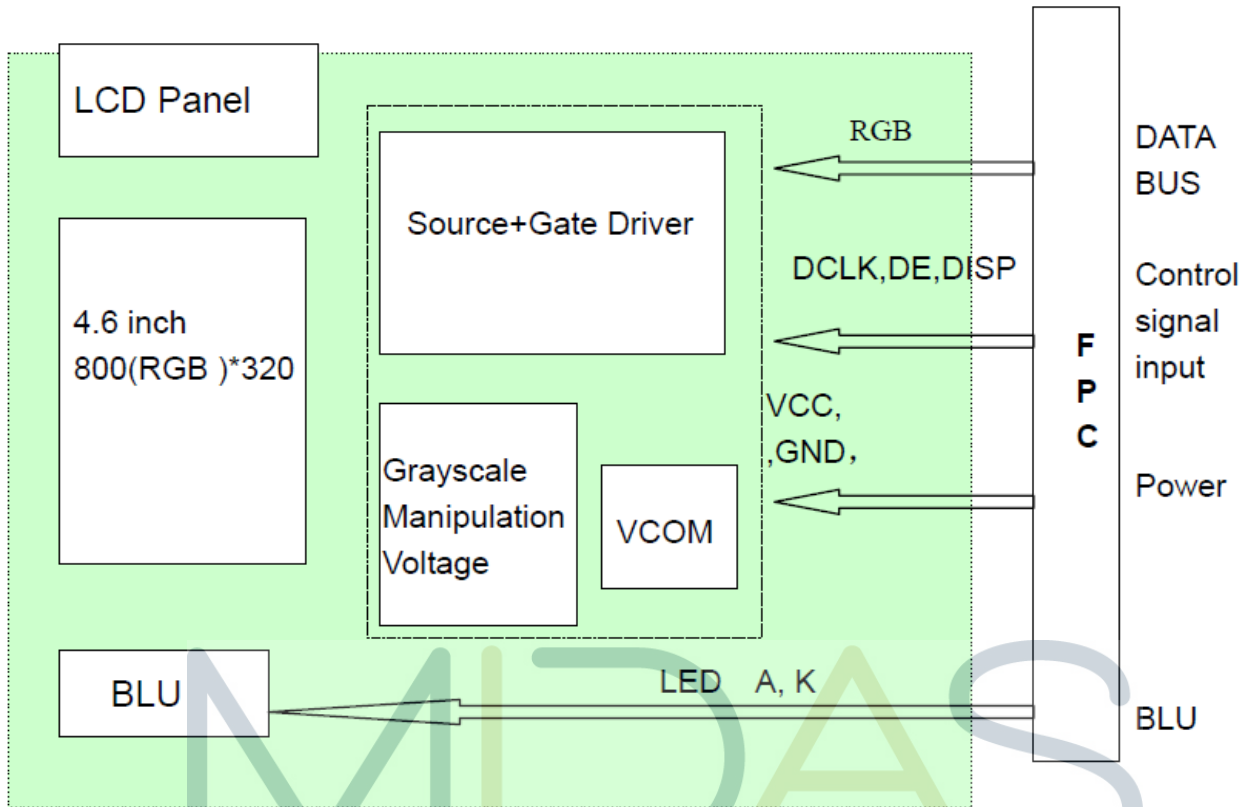

MIDAS

design • manufacture • supply

## 7. Absolute Maximum Ratings

Item	Symbol	Min	Typ	Max	Unit
Operating Temperature	TOP	-20	-	+70	°C
Storage Temperature	TST	-30	-	+80	°C

Note: Device is subject to be damaged permanently if stresses beyond those absolute maximum ratings listed above

- Temp.  $\leq 60^{\circ}\text{C}$ , 90% RH MAX. Temp.  $> 60^{\circ}\text{C}$ , Absolute humidity shall be less than 90% RH at  $60^{\circ}\text{C}$

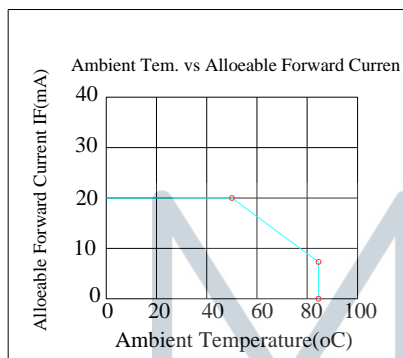

MIDAS

design • manufacture • supply



## 8. Electrical Characteristics

### 8.1. Operating conditions:

Item	Symbol	Values			Unit	Remark
		MIN	TYP	MAX		
Power Voltage	DVDD	3.0	3.3	3.6	V	Note 2
	AVDD	10.2	10.4	10.6	V	
	VGH	15.3	16.0	16.7	V	
	VGL	-6.7	-6.0	-5.3	V	
Input signal voltage	VCOM	3.09	4.09	5.09	V	Note 4
Input logic high voltage	VIH	0.7DVDD		DVDD	V	Note 3
Input logic low voltage	VIL	0		0.7DVDD	V	

Note 1: Be sure to apply DVDD and VGL to the LCD first, and then apply VGH.

Note 2: DVDD setting should match the signals output (refer to note3) of customer's system board.

Note 3: DCLK, HS, VS, RESET, U/D, L/R, DE, R0~R7, G0~G7, B0~B7, MODE, DITHB

Note 4: Typical VCOM is only a reference value. It must be optimized according to each LCM. Please use VR and base on below application circuit.

### 8.2. Current Consumption

Item	Symbol	Values			Unit	Remark
		MIN	TYP	MAX		
Current for driver	IGH	-	0.50	1	mA	VGH=16.0V
	IGL	-	0.54	1	mA	VGL=-6.0V
	IDVDD	-	4.2	10	mA	DVDD=3.3V
	IAVDD	-	19	50	mA	AVDD=10.4V

### 8.3. LED driving conditions

Item	Symbol	MIN	TYP	MAX	Unit	Remark
Forward Current	IF	-	40	50	mA	
Forward Voltage	VF		19.6	21	V	
Backlight Power consumption	WBL	-	0.784	-1.05	W	
LED Lifetime		-	25000	-	Hrs	

Note 1 : There are 1 Groups LED

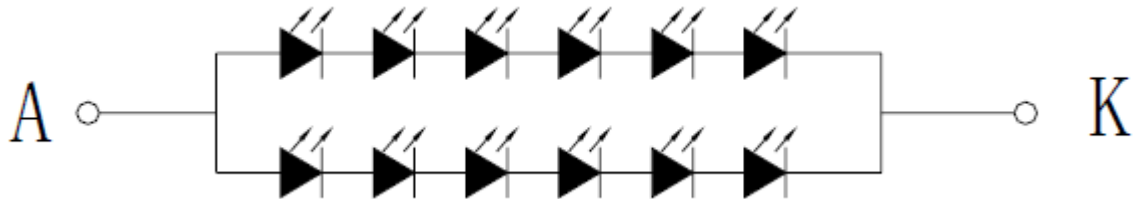

Note 2 :  $T_a = 25\text{ }^\circ\text{C}$

Note 3 : Brightness to be decreased to 50% of the initial value

Note 4 : The single LED lamp case

# MIDAS

design • manufacture • supply

# 9.Interface Timing

## 9.1. Power Sequence

To prevent a latch-up or DC operation of the LCD module, the power on/off sequence should be as the diagram below.

### a. Power on sequence:

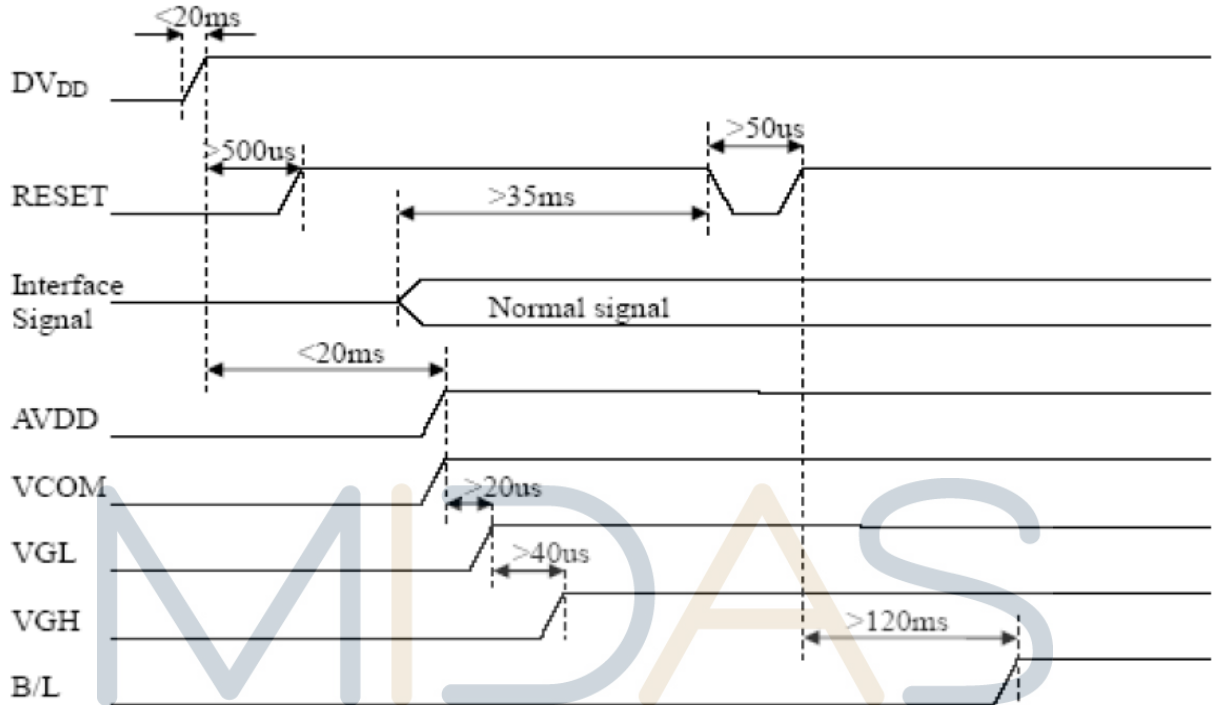

### b. Power off sequence:

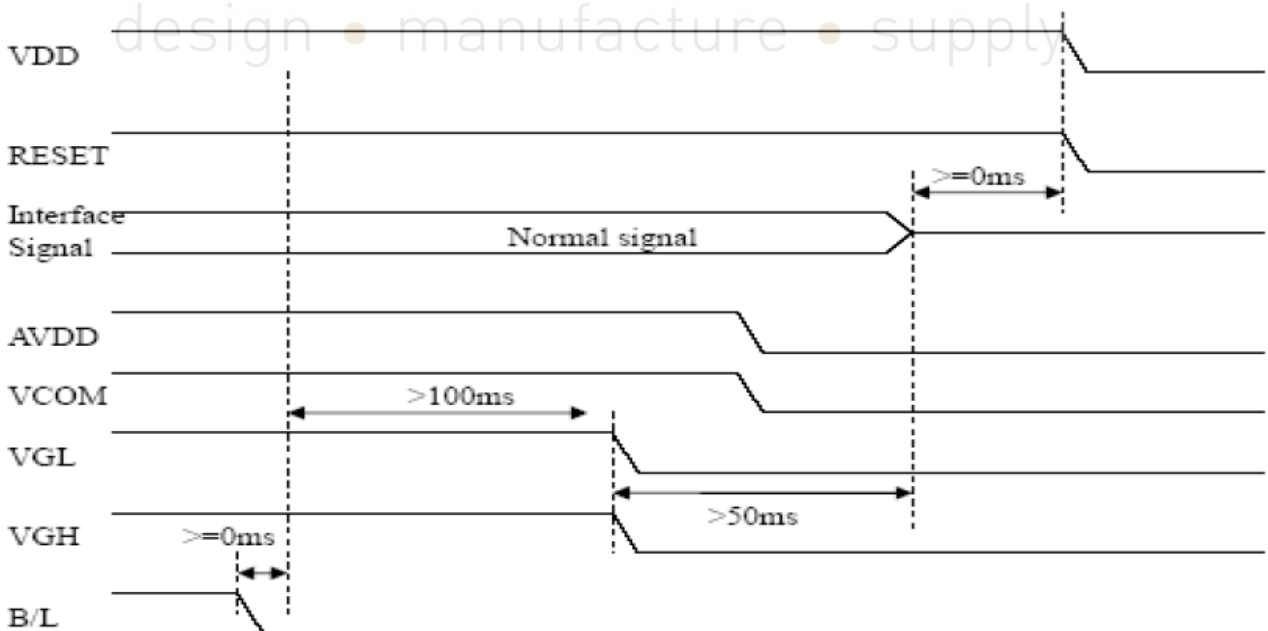

### 9.2. Timing Conditions

Item	Symbol	Values			Unit	Remark
		MIN	TYP	MAX		
HS setup time	Thst	8	-	-	ns	
HS hold time	Thhd	8	-	-	ns	
VS setup time	Tvst	8	-	-	ns	
VS hold time	Tvhd	8	-	-	ns	
Data setup time	Tdsu	8	-	-	ns	
Data hold time	Tdhd	8	-	-	ns	
DE setup time	Tesu	8	-	-	ns	
DE hold time	Tehd	8	-	-	ns	
DVDD power on slew rate	Tpor	-	-	20	ms	From 0 to 90% DVDD
RESET pulse width	Trst	1	-	-	ms	
DCLK cycle time	Tcoh	20	-	-	ns	
DCLK pulse duty	Tcwh	40	50	60	%	

### 9.3. Timing Diagram

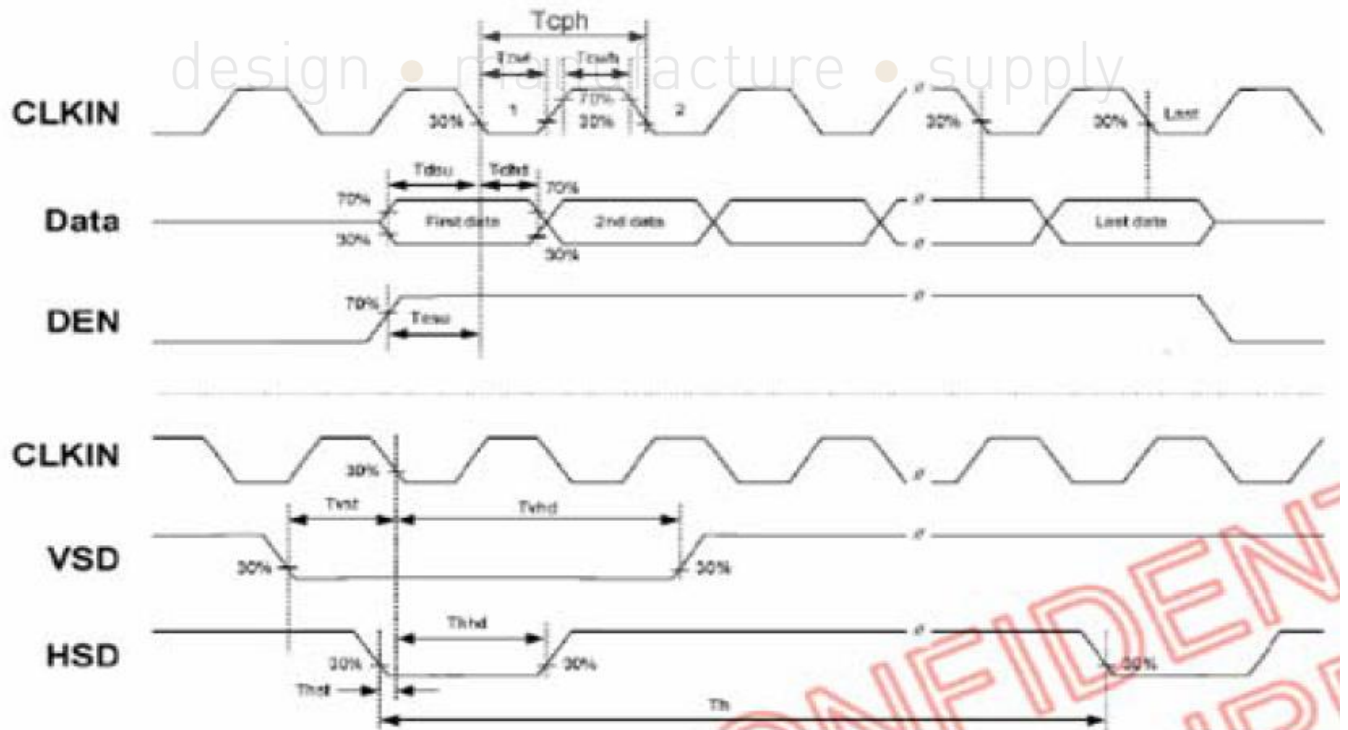

#### 9.4. Timing

Item	Symbol	Values			Unit	Remark
		MIN	TYP	MAX		
Horizontal Display Area	thd	-	800	-	DCLK.	
DCLK Frequency	fclk	26.4	33.3	46.8	MHz	
One Horizontal Line	th	862	1056	1200	DCLK	
HS pulse width	thpw	1	-	40	OCLK	
HS Blanking	thb	46	46	46	DCLK	
HS Front Porch	lfp	16	210	354	OCLK.	

Item	Symbol	Values			Unit	Remark
		MIN	TYP	MAX		
Vertical Display Area	tvd	-	480	-	TH	
VS period time	tv	510	525	650	TH	
VS pulse width	tvpw	1	-	20	TH	
VS Blanking	tvp	23	23	23	TH	
VS Front Porch	tvfp	7	22	147	TH	

## 9.5. Data Input Format

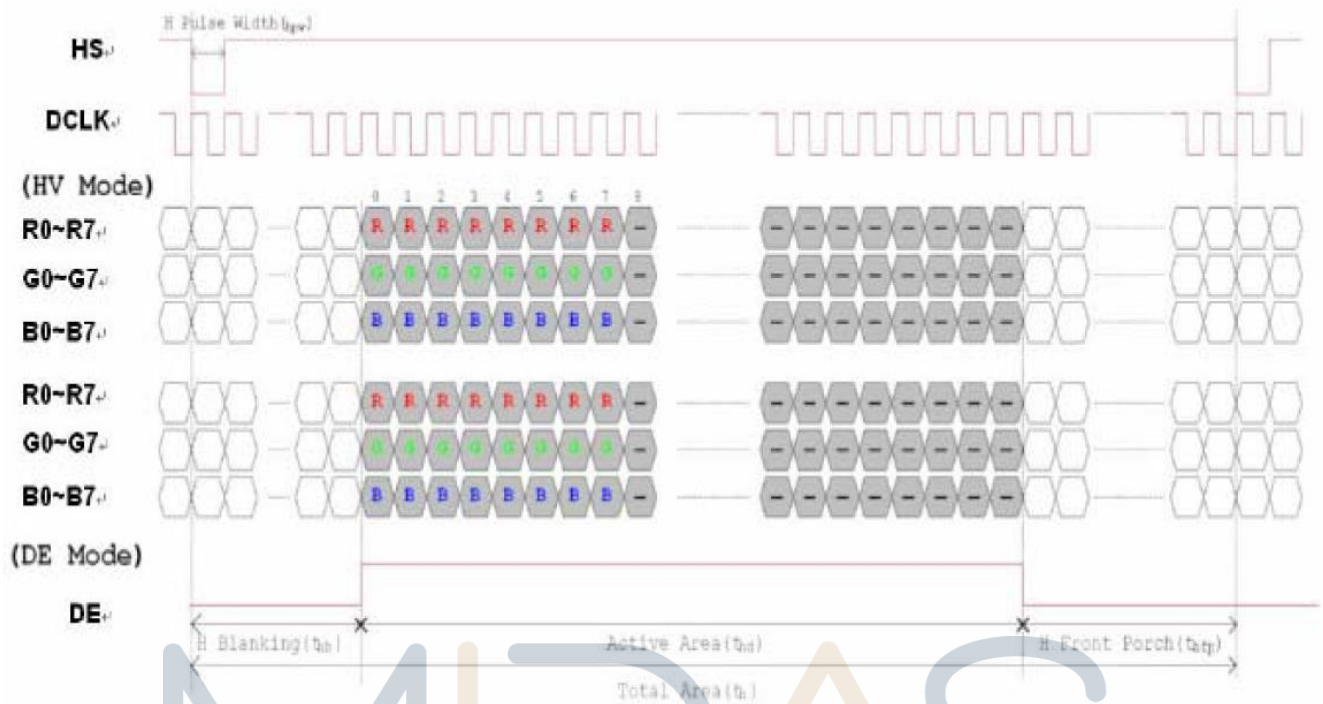

Figure 1 Horizontal input timing diagram.

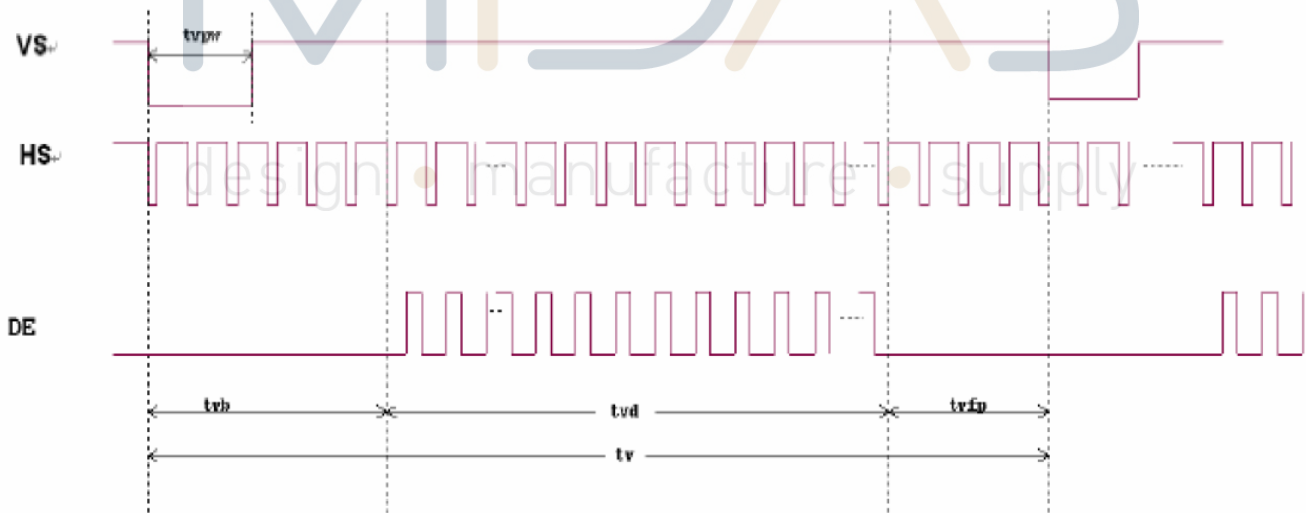

Figure 2 Vertical input timing diagram.

## 10. Optical Characteristics

Item	Symbol	Condition.	Min	Typ.	Max.	Unit	Remark	
Response time	Tr	$\theta=0^\circ$ 、 $\phi=0^\circ$	-	20	30	ms	Note 3	
	Tf		-	20	30			
Contrast ratio	CR	At optimized viewing angle	500	600	-	-	Note 4	
Color Chromaticity	White	$\theta=0^\circ$ 、 $\phi=0$	Wx	0.324	0.326	0.328	-	Note 2,5
			Wy	0.364	0.366	0.368	-	
Viewing angle (Gray Scale Inversion Direction)	Hor.	$CR \geq 10$	$\theta_R$	60	70	-	Deg	Note 1
			$\theta_L$	60	70	-		
	Ver.		$\phi_T$	40	50	-		
			$\phi_B$	60	70	-		
Brightness	-	-	350	400	-	cd/ m <sup>2</sup>	Center of display	

Ta=25±2℃,

Note 1: Definition of viewing angle range

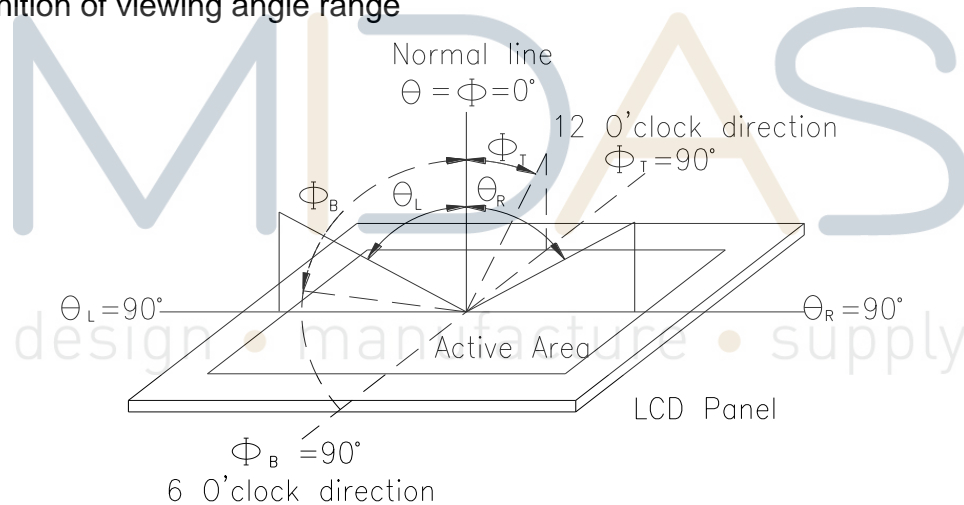

Fig. 10.1. Definition of viewing angle

Note 2: Test equipment setup:

After stabilizing and leaving the panel alone at a driven temperature for 10 minutes, the measurement should be executed. Measurement should be executed in a stable, windless, and dark room. Optical specifications are measured by Topcon BM-7 or BM-5 luminance meter 1.0° field of view at a distance of 50cm and normal direction.

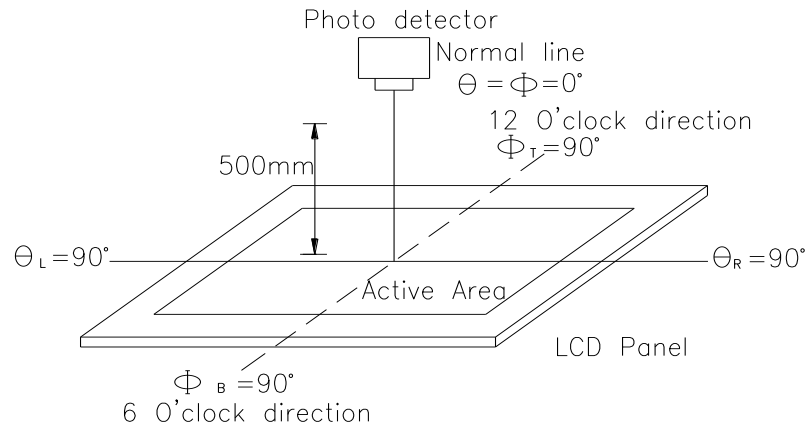
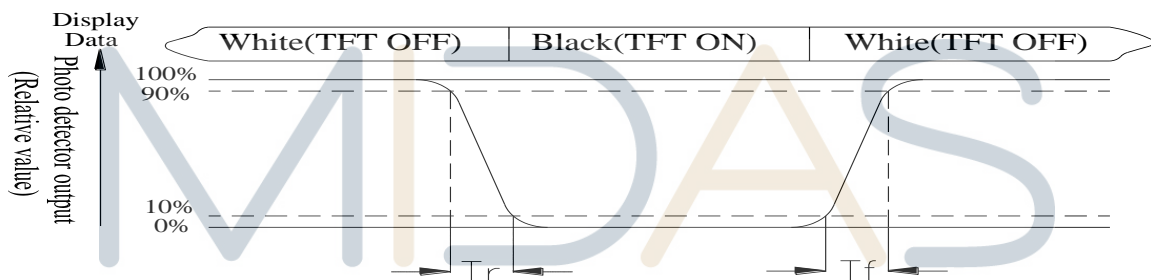

Fig. 10.2. Optical measurement system setup

Note 3: Definition of Response time:

The response time is defined as the LCD optical switching time interval between “White” state and “Black” state. Rise time,  $T_r$ , is the time between photo detector output intensity changed from 90% to 10%. And fall time,  $T_f$ , is the time between photo detector output intensity changed from 10% to 90%



Note 4: Definition of contrast ratio:

The contrast ratio is defined as the following expression.

$$\text{Contrast ratio (CR)} = \frac{\text{Luminance measured when LCD on the "White" state}}{\text{Luminance measured when LCD on the "Black" state}}$$

Note 5: White  $V_i = V_{i50} \pm 1.5V$

Black  $V_i = V_{i50} \pm 2.0V$

“±” means that the analog input signal swings in phase with VCOM signal.

“±” means that the analog input signal swings out of phase with VCOM signal.

The 100% transmission is defined as the transmission of LCD panel when all the input terminals of module are electrically opened.

Note 6: Definition of color chromaticity (CIE 1931)

Color coordinates measured at the center point of LCD

Note 7: Measured at the center area of the panel when all the input terminals of LCD panel are electrically opened.



# 11. Reliability

Content of Reliability Test (Wide temperature, -20°C~70°C)

Environmental Test			
Test Item	Content of Test	Test Condition	Note
High Temperature storage	Endurance test applying the high storage temperature for a long time.	80°C 200hrs	2
Low Temperature storage	Endurance test applying the low storage temperature for a long time.	-30°C 200hrs	1,2
High Temperature Operation	Endurance test applying the electric stress (Voltage & Current) and the thermal stress to the element for a long time.	70°C 200hrs	—
Low Temperature Operation	Endurance test applying the electric stress under low temperature for a long time.	-20°C 200hrs	1
High Temperature/ Humidity Operation	The module should be allowed to stand at 60°C,90%RH max	60°C,90%RH 96hrs	1,2
Thermal shock resistance	The sample should be allowed stand the following 10 cycles of operation  <div style="text-align: center;"> <p>-20°C    25°C    70°C</p> <p>30min    5min    30min</p> <p>1 cycle</p> </div>	-20°C/70°C 10 cycles	—
Vibration test	Endurance test applying the vibration during transportation and using.	Total fixed amplitude : 3 1.5mm Vibration Frequency : 10~55Hz One cycle 60 seconds to 3 directions of X,Y,Z for Each 15 minutes	3
Static electricity test	Endurance test applying the electric stress to the terminal.	VS=±600V(contact) ,±800v(air), RS=330Ω CS=150pF 10 times	—

Note1: No dew condensation to be observed.

Note2: The function test shall be conducted after 4 hours storage at the normal Temperature and humidity after remove from the test chamber.

Note3: The packing have to including into the vibration testing.