

SPECIFICATIONS FOR LCD MODULE

CUSTOMER	
CUSTOMER PART NO.	
AMPIRE PART NO.	AM-1024768Q2TMQW-00H
APPROVED BY	
DATE	

- Approved For Specifications
- Approved For Specifications & Sample

AMPIRE CO., LTD.

4F., No.116, Sec. 1, Xintai 5th Rd., Xizhi Dist., New Taipei City221, Taiwan (R.O.C.)

新北市汐止區新台五路一段 116 號 4 樓(東方科學園區 A 棟)

TEL:886-2-26967269 , FAX:886-2-26967196 or 26967270

APPROVED BY	CHECKED BY	ORGANIZED BY

RECORD OF REVISION

Revision Date	Page	Contents	Editor
2013/04/22	-	New Release	Rober
2013/4/24	3	Correct PHYSICAL SPECIFICATIONS	Rober

1. FEATURES

The TFT is a color active matrix TFT LCD module using amorphous silicon TFT's (Thin Film Transistors) as an active switching devices. This module is composed of a TFT LCD panel, a driving circuit and a back light system. This TFT LCD has a 15.0 inch diagonally measured active display area with (1024 x 768 pixel) resolution.

- (1) 15.0 inch configuration
- (2) One channel LVDS interface
- (3) 16.2M color by 8 bit R.G.B signal input
- (4) RoHS Compliance

2. PHYSICAL SPECIFICATIONS

Item	Specifications	Unit	Note
LCD size	15.0" (Diagonal)	inch	
Active area	304.128 (H) ×228.096 (V)	mm	
Number of pixels	1024(H) ×768(V)	pixels	
Pixel pitch	0.297(H) × 0.297(V)	mm	
Pixel arrangement	RGB Vertical stripe		
Display colors	16.2M	colors	
Display mode	Normally white		
Dimensional outline	326.5 (Typ) ×253.5 (Typ) ×12.7(D)	mm	
Back-light	Single LED (Side-Light type)		
Gray Inversion	6	H	
Weight	TBD	g	
Surface treatment	Anti-glare, Hard-Coating (3H)		

3. ABSOLUTE MAX. RATINGS

The followings are maximum values which, if exceed, may cause faulty operation or damage to the unit.

Item	Symbol	Values		UNIT	Note
		Min.	Max.		
LED Power Supply Voltage	V _{LED}	-0.3	15.0	V	GND=0
Logic Supply Voltage	V _{DD}	-0.3	5.0	V	
Operating Temperature	T _{OPA}	-30	80	°C	
Storage Temperature	T _{STG}	-30	80	°C	

4. ELECTRICAL CHARACTERISTICS

4.1 TFT LCD Module

Item	Symbol	Values			UNIT	Note
		Min.	Typ.	Max.		
Power voltage	VDD	3.0	3.3	3.6	V	Note1
Current of power supply	IDD	-	0.3	-	A	VDD=3.3V Black pattern
Power voltage for LED driver	VLED	-	12	-	V	
LED driver current of power supply	ILED	-	3		A	VLED=12V ADJ=100%

Note 1: VDD-dip condition :

when $2.7V \leq VDD < 3.0V$, $t_d \leq 10ms$.

$VDD > 3.0V$, VDD-dip condition should be same as VDD-turn-con condition.

4.3 LVDS Input Data Mapping

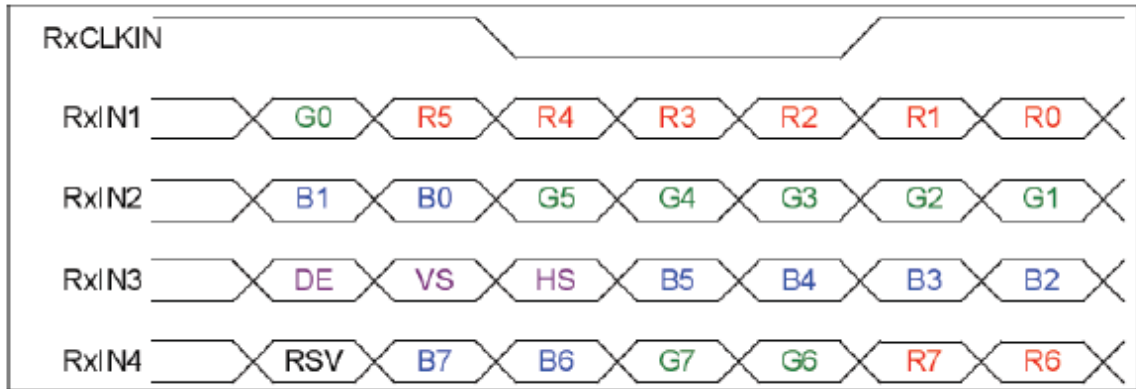

4.4 Timing characteristics of input signals

Synchronization Method : DE only

Parameter	Symbol	Unit	Min.	Typ.	Max.
LVDS Clock Frequency <single >	fdck	MHz	50	65	80
H Total Time	Thp	clocks	1056	1344	1720
H Active Time	HA	clocks	1024	1024	1024
H Front Porch	Thfp	clocks	-	48	-
H Sync Pulse Width	HSPW	clocks	-	32	-
H Back Porch	Thbp	clocks	-	240	-
H Frequency	fh	kHz	46.32	48.36	59.40
V Total Time	Tvp	lines	772	806	990
V Active Time	VA	lines	768	768	768
V Front Porch	Tvfp	lines	-	3	-
V Sync Pulse Width	VSPW	lines	-	12	-
V Back Porch	Tvbp	lines	-	23	-
V Frequency	fv	Hz		60	

Note: H Blank area and V Blank area can not be changed at every frame

4.5 Backlight Driving Conditions

Item	Symbol	Values			Unit	Note
		Min.	Typ.	Max.		
LED Driver voltage	VLED	-	12	-	V	
Power Supply Current For LED Driver	ILED	-	3	-	A	VLED=12V VADJ=5V (duty 100%)
ADJ Input Voltage	V _{ADJ}	-	5	VLED	V	duty=100% Note(3)
LED voltage	V _{AK}	--	45.5	--	V	I _{AK} =600mA Ta=25°C
LED current	I _{AK}	--	600	--	mA	Ta=25°C
		--	480	--	mA	Ta=60°C
LED Life Time	-	--	50K	--	Hour	Note (2)

Note (1) The constant current source is needed for white LED back-light driving.

When LCM is operated over 60 deg.C ambient temperature, the I_L of the LED back-light should be adjusted to 480mA max

There are 4 Groups LED shown as below , V_{LEDA-LEDK}=45.5V , Ta=25°C

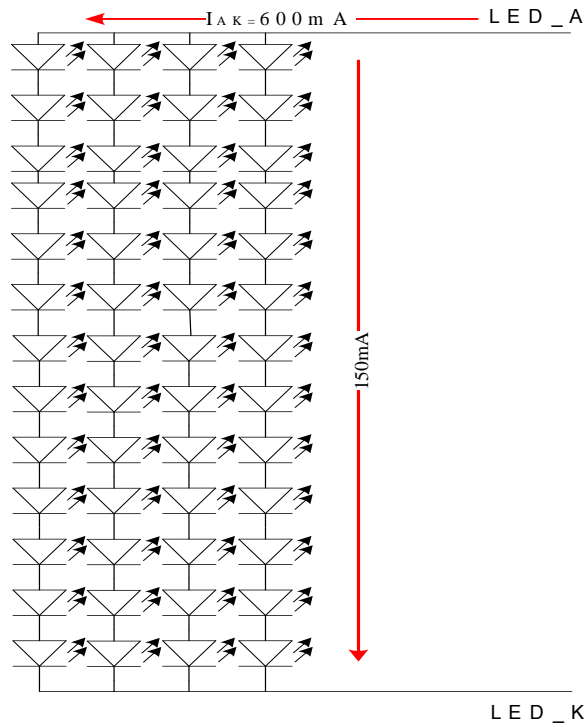

Note2 : Condition: $T_a=25^{\circ}\text{C}$, continuous lighting

Life time is estimated data.

Definitions of failure:

1. LCM brightness becomes half of the minimum value.
2. LED doesn't light normally.

When LCM is operated over 40°C ambient temperature, the I_{LED} should be follow :

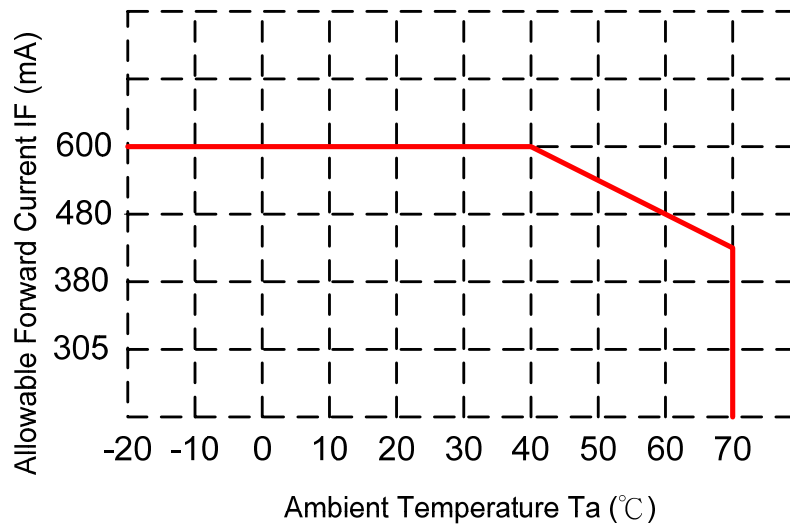

5. OPTICAL SPECIFICATION

5.1 Optical specification

Item	Symbol	Condition	Values			Unit	Note
			Min.	Typ.	Max.		
Viewing angle	θL	$(CR \geq 10)$	70	80	--	degree	Note1 Note2
	θR		70	80	--		
	θU		70	80	--		
	θD		60	80	--		
Response time	TR	Normal $\theta = \Phi = 0^\circ$	--	5	--	msec	Note3
	TF		--	20	--	msec	
Contrast ratio	CR		450	800	--	--	Note2
Color chromaticity	WX		0.27	0.32	0.37	--	Note1 Note4
	WY		0.29	0.34	0.39	--	
	RX		0.57	0.62	0.67	--	
	RY		0.30	0.35	0.4	--	
	GX		0.27	0.32	0.37	--	
	GY		0.58	0.63	0.68	--	
	BX		0.1	0.15	0.2	--	
	BY	0.02	0.07	0.12.	--		
Luminance	L	800	1000	--	cd/m ²	Note4	
Luminance uniformity	YU	70	75	--	%	Note5	

5.2 Measuring Condition

- Measuring surrounding : dark room
- Ambient temperature : 25±2℃
- 15min. warm-up time

5.2 Measuring Equipment

The optical characteristics should be measured in dark room. After 30 minutes operation, the optical properties are measured at the center point of the LCD screen. (Response time is measured by Photo detector TOPCON BM-7 of view : 1° / Height : 120mm.)

Note 1 : Definition of viewing angle range

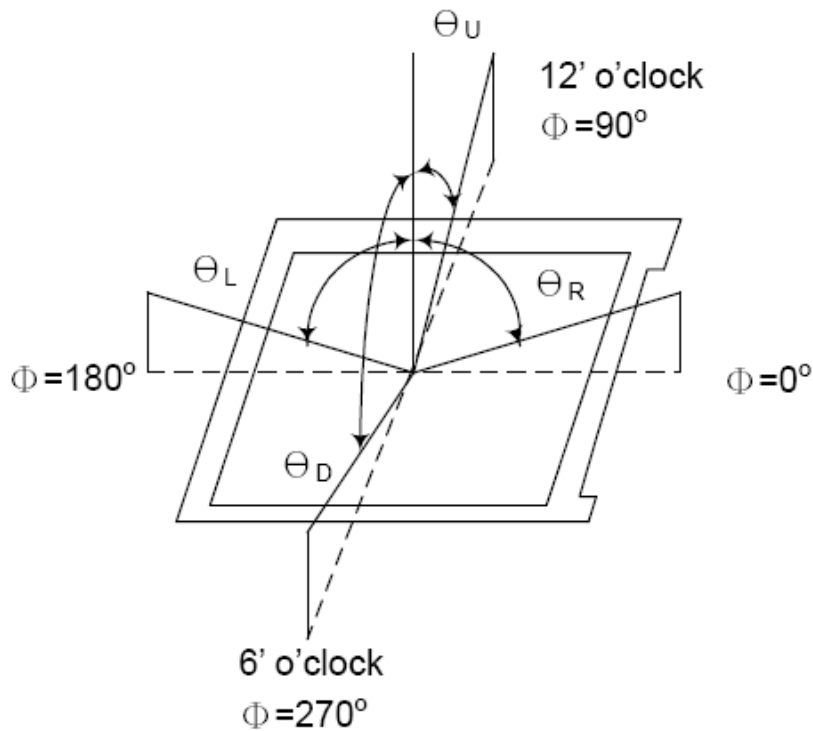

Note 2 : Definition of Contrast Ratio (CR) :
measured at the center point of panel

$$CR = \frac{\text{Luminance with all pixels white}}{\text{Luminance with all pixels black}}$$

Note 3 : Definition of Response time : Sum of Tr and T

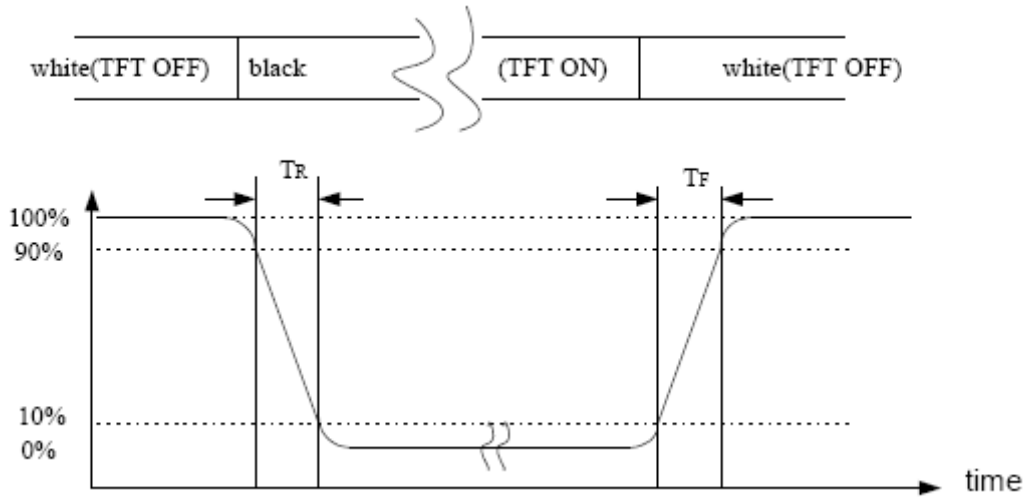

Note 4 : Definition of optical measurement setup

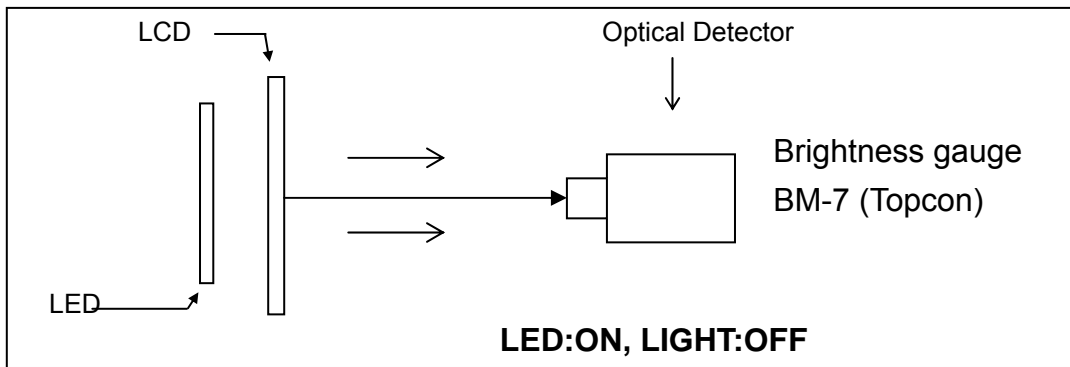

Note 5 : Definition of brightness uniformity

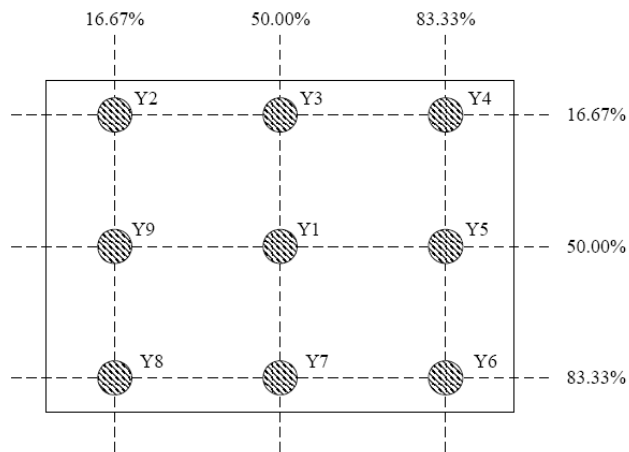

(Min Luminance of 9 points)

$$\text{Luminance uniformity} = \frac{\text{Min Luminance of 9 points}}{\text{Max Luminance of 9 points}} \times 100\%$$

Note 6 : Rubbing Direction (The different Rubbing Direction will cause the different optima view direction)

Note 7 : Condition: $T_a=25^{\circ}\text{C}$, Life time is estimated data.

Definitions of failure:

- i. LCM brightness becomes half of the minimum value.
- ii. LED doesn't light normally.

6. BLOCK DIAGRAM

6.1 TFTLCD Module

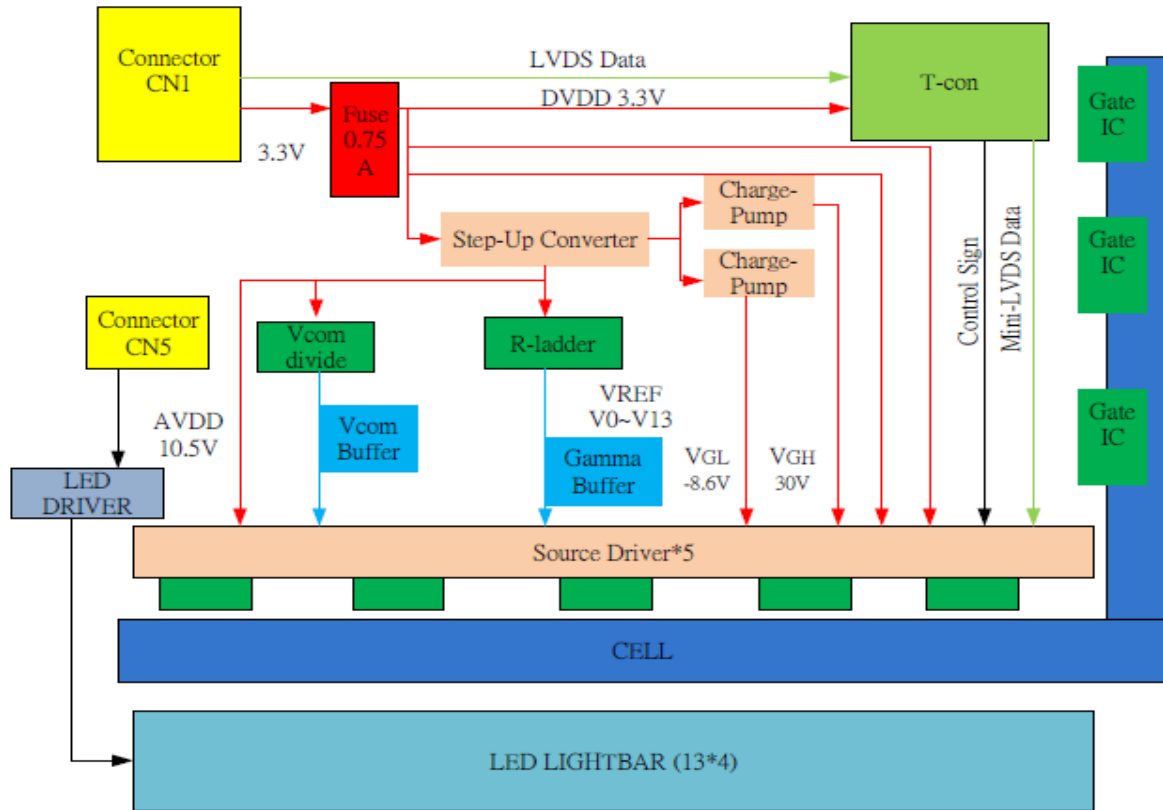

6.2 Pixel format

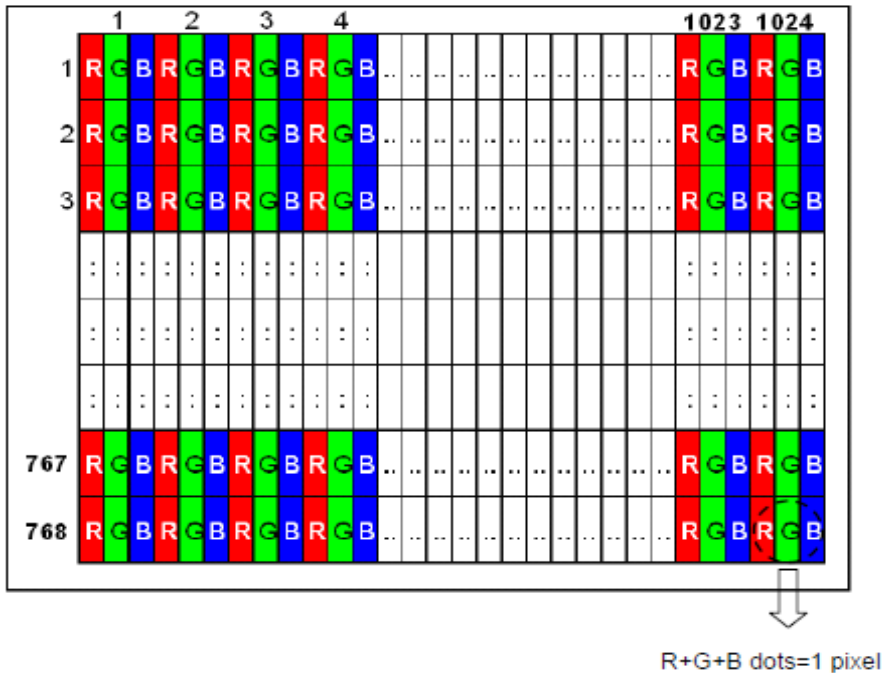

7.INTERFACE

7.1 Electrical Interface Connection

CN1(Input signal): MSB240420HD

Pin No.	Symbol	Description	Note
1	VDD	3.3V Power	
2	VDD	3.3V Power	
3	VSS	Ground	
4	REV	Reverse Scan selection	Note1*
5	Rin1-	LVDS Data Signal - Rin1-	
6	Rin1+	LVDS Data Signal+ Rin1+	
7	VSS	Ground	
8	Rin2-	LVDS Data Signal – Rin2-	
9	Rin2+	LVDS Data Signal+ Rin2+	
10	VSS	Ground	
11	Rin3-	LVDS Data Signal – Rin3-	
12	Rin3+	LVDS Data Signal+ Rin3+	
13	VSS	Ground	
14	CIKIN-	LVDS Clock Signal - CIKIN-	
15	CIKIN+	LVDS Clock Signal+ CIKIN+	
16	GND	Ground	
17	Rin4-	LVDS Data Signal – Rin4-	
18	Rin4+	LVDS Data Signal+ Rin4+	
19	VSS	Ground	
20	NC	6/8bit Selection	Note2*

Note1* : About REV Please refer to <2.1.2 Display Scanning Directions>;

Note2* : About Pin20---NC 8 Bit=NC orGND

6 Bit=Pull High

CN4(Input signal): FPHTI-104TTW000

Pin No.	Symbol	Description	Note
1	VIN	12V Power	
2	LED_EN	Function selection:5V-Backlight ON , GND-Backlight OFF	
3	GND	Ground	
4	PWN	Adjust for LED brightness	

8. Power On/Off Sequence

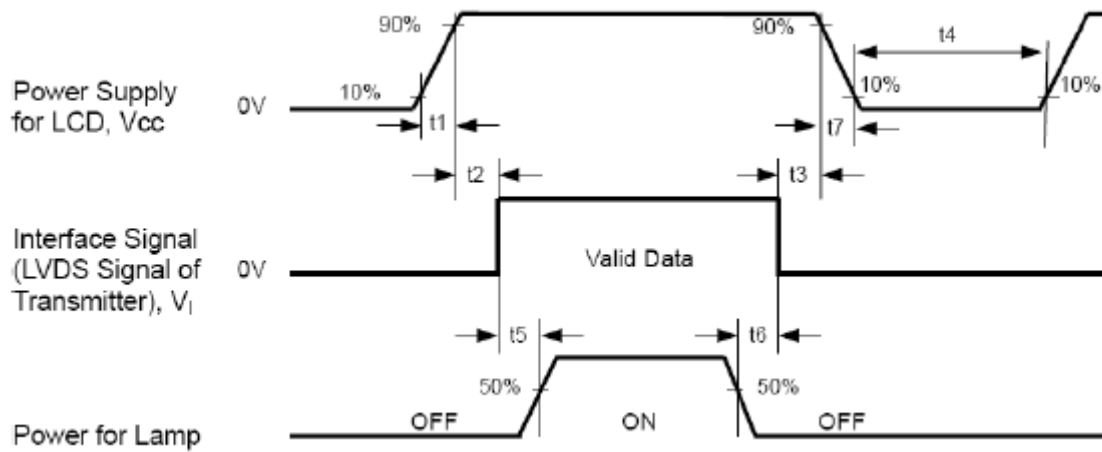

Parameter	Symbol	Unit	min	typ	max
VDD Rise Time	T1	ms	0.02	-	10
VDD Good to Signal Valid	T2	ms	0	-	20
Signal Disable to Power Down	T3	ms	0	-	1000
Power Off	T4	ms	1000	-	
Signal Valid to Backlight On	T5	ms	300	-	
Backlight Off to Signal Disable	T6	ms	200	-	
VDD Fall Time	T7	ms	0	-	100

9. RELIABILITY TEST CONDITIONS

Item	Test Conditions	Note
High Temperature Storage	Ta = 80°C 240 hrs	
Low Temperature Storage	Ta = -30°C 240 hrs	
High Temperature Operation	Ts = 80°C 240 hrs	
Low Temperature Operation	Ta = -30°C 240 hrs	
Operating Humidity	10~80 %RH	
Storage Humidity	10~80 %RH	

10. HANDLING & CAUTIONS

10.1 Cautions when taking out the module

Pick the pouch only, when taking out module from a shipping package.

10.2 Cautions for handling the module

10.2.1 As the electrostatic discharges may break the LCD module, handle the LCD module with care. Peel a protection sheet off from the LCD panel surface as slowly as possible.

10.2.2 As the LCD panel and backlight element are made from fragile glass material, impulse and pressure to the LCD module should be avoided.

10.2.3 As the surface of the polarizer is very soft and easily scratched, use a soft dry cloth without chemicals for cleaning.

10.2.4 Do not pull the interface connector in or out while the LCD module is operating.

10.2.5 Put the module display side down on a flat horizontal plane.

10.2.6 Handle connectors and cables with care.

10.3 Cautions for the operation

10.3.1 When the module is operating, do not lose MCLK, DE signals. If any one of these signals were lost, the LCD panel would be damaged.

10.3.2 Obey the supply voltage sequence. If wrong sequence were applied, the module would be damaged.

10.4 Cautions for the atmosphere

10.4.1 Dewdrop atmosphere should be avoided.

10.4.2 Do not store and/or operate the LCD module in a high temperature and/or humidity atmosphere. Storage in an electro-conductive polymer-packing pouch and under relatively low temperature atmosphere is recommended.

10.5 Cautions for the module characteristics

10.5.1 Do not apply fixed pattern data signal to the LCD module at product aging.

10.5.2 Applying fixed pattern for a long time may cause image sticking.

10.6 Other cautions

10.6.1 Do not disassemble and/or re-assemble LCD module.

10.6.2 Do not re-adjust variable resistor or switch etc.

10.6.3 When returning the module for repair or etc, please pack the module not to be broken. We recommend using the original shipping packages.

10.6.4 AMIPRE will provide one year warrantee for all products and three months warrantee for all repairing products.

10.6.5

The residual image may exist if the same display pattern is shown for hours. This residual image, however, disappears when another display pattern is shown or the drive is interrupted and left for a while. But this is not a problem on reliability.

PRELIMINARY

The contents of this document are confidential and must not be disclosed wholly or in part to any third party without the prior written consent of AMPIRE CO., LTD.

REV	REVISION RECORD	DATE NAME
0	NEW RELEASE	01-04-13 EMILY

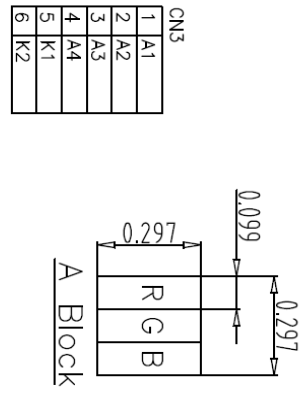

CN1	
1	VDD
2	VDD
3	VSS
4	REV
5	Rin1-
6	Rin1+
7	VSS
8	Rin2-
9	Rin2+
10	VSS
11	Rin3-
12	Rin3+
13	VSS
14	CIKIN-
15	CIKIN+
16	GND
17	Rin4-
18	Rin4+
19	VSS
20	INC

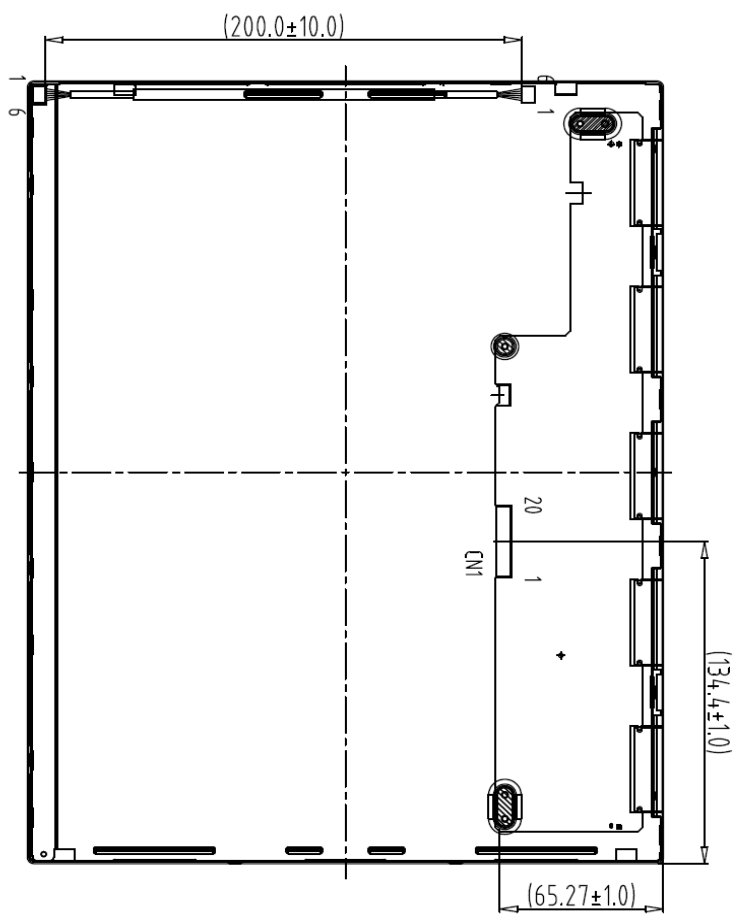

Back view

Note:
 1. Unless indicated, Tolerance "±0.5"
 2. UV Glue For OLB Protection.

- CN1:P1.25 20Pin/STM MSB240420HD or Equivalent; Mating Connector: STM P240420 or Equivalent
- CN3:P1.0 6pin, Mating Connector: Cvilux C11406M1HRL-NH or Equivalent
- LCD 1024X3(R.G.B)x768=> 15.0" Digital TFT LCD

1	2	7	TOLERANCE	GRADE(±)	A	B	DIM.	MAN	DRW.	EMILY	DATE	DATE	DATE	DATE	DATE
		8									01-04-13				
		9													
		10													
		11													
		12													

晶采光电科技
 1024768Q2
 DWG. NO. *130108MA
 SHEET 1 OF 1

