

DRAWING MADE IN THIRD ANGLE PROJECTION

THIS DRAWING IS UNPUBLISHED. RELEASED FOR PUBLICATION

© COPYRIGHT 19 BY AMP INCORPORATED, HARRISBURG, PA. ALL INTERNATIONAL RIGHTS RESERVED. AMP PRODUCTS MAY BE COVERED BY U.S. AND FOREIGN PATENTS AND/OR PATENTS PENDING.

		REVISIONS			
P	F	ZONE/LTR	DESCRIPTION	DATE	APPROVED
		O	RLSD PER TTI 85-50	6/12/85	RP/RS
✓			REV PER ECN CM 243		
✓		A	REV PER ECN CM 262	7/14/85	DM/RS
✓		B	REV PER CM-626	6/28/86	KL/RS
✓		C	REVISED PER CM-3000	7-12-90	MC/RS

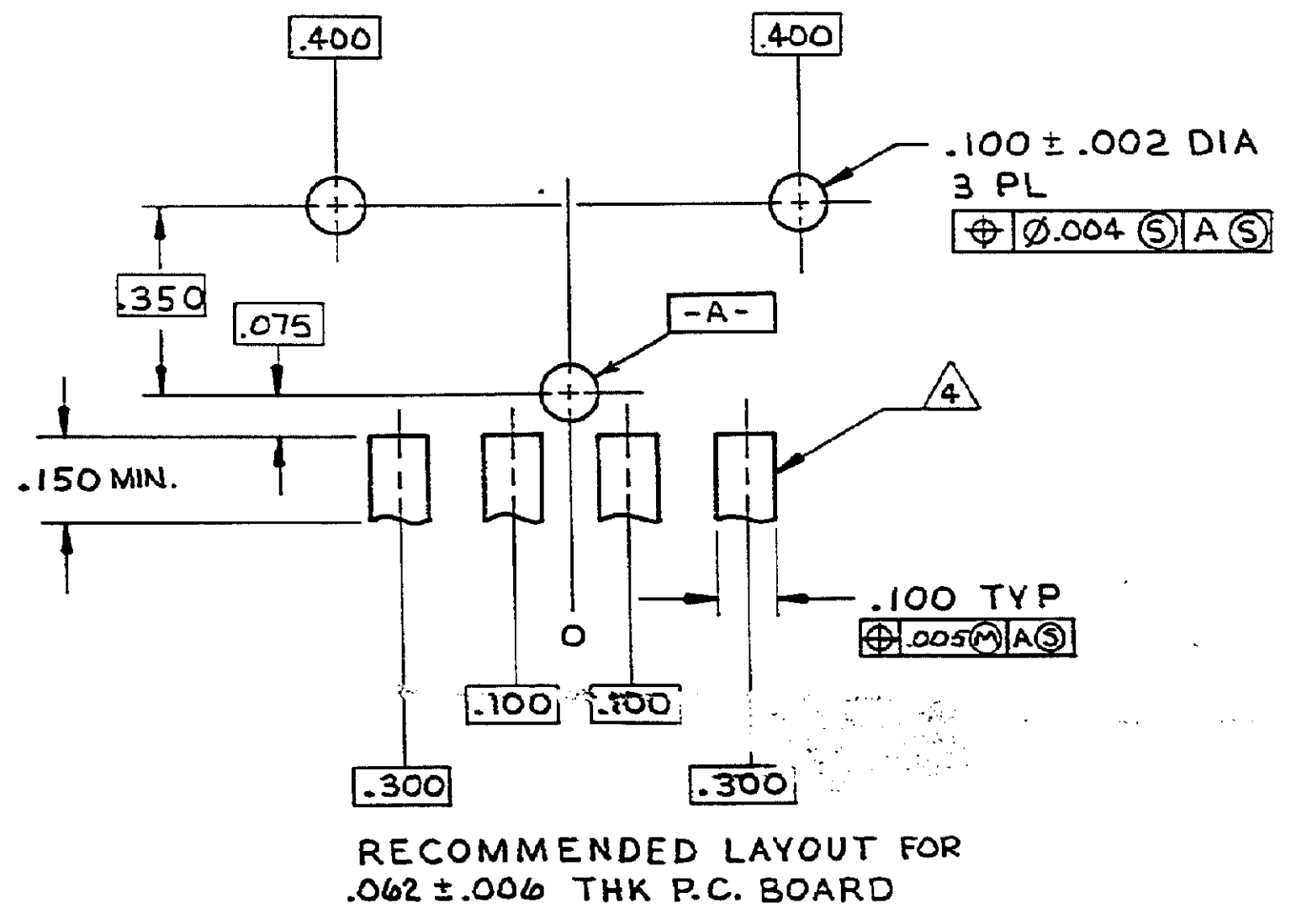
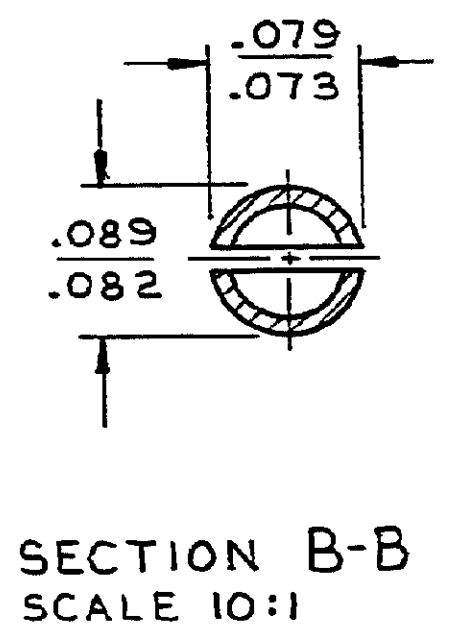
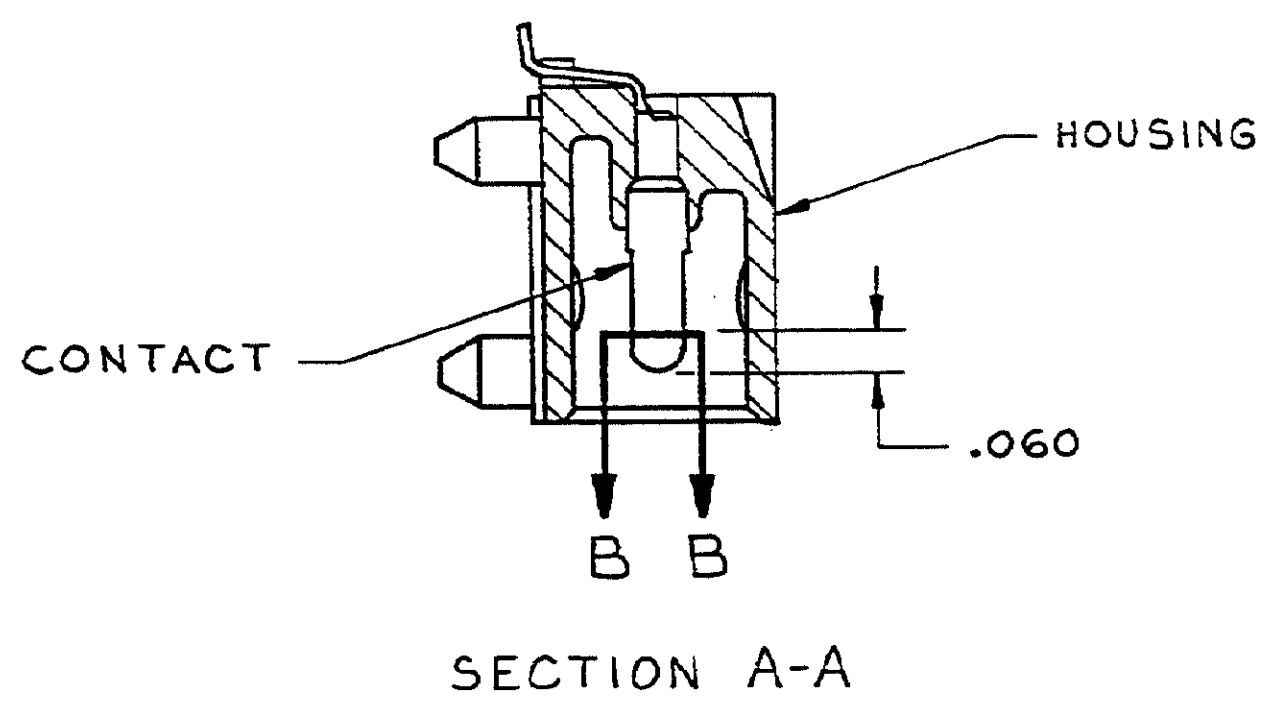
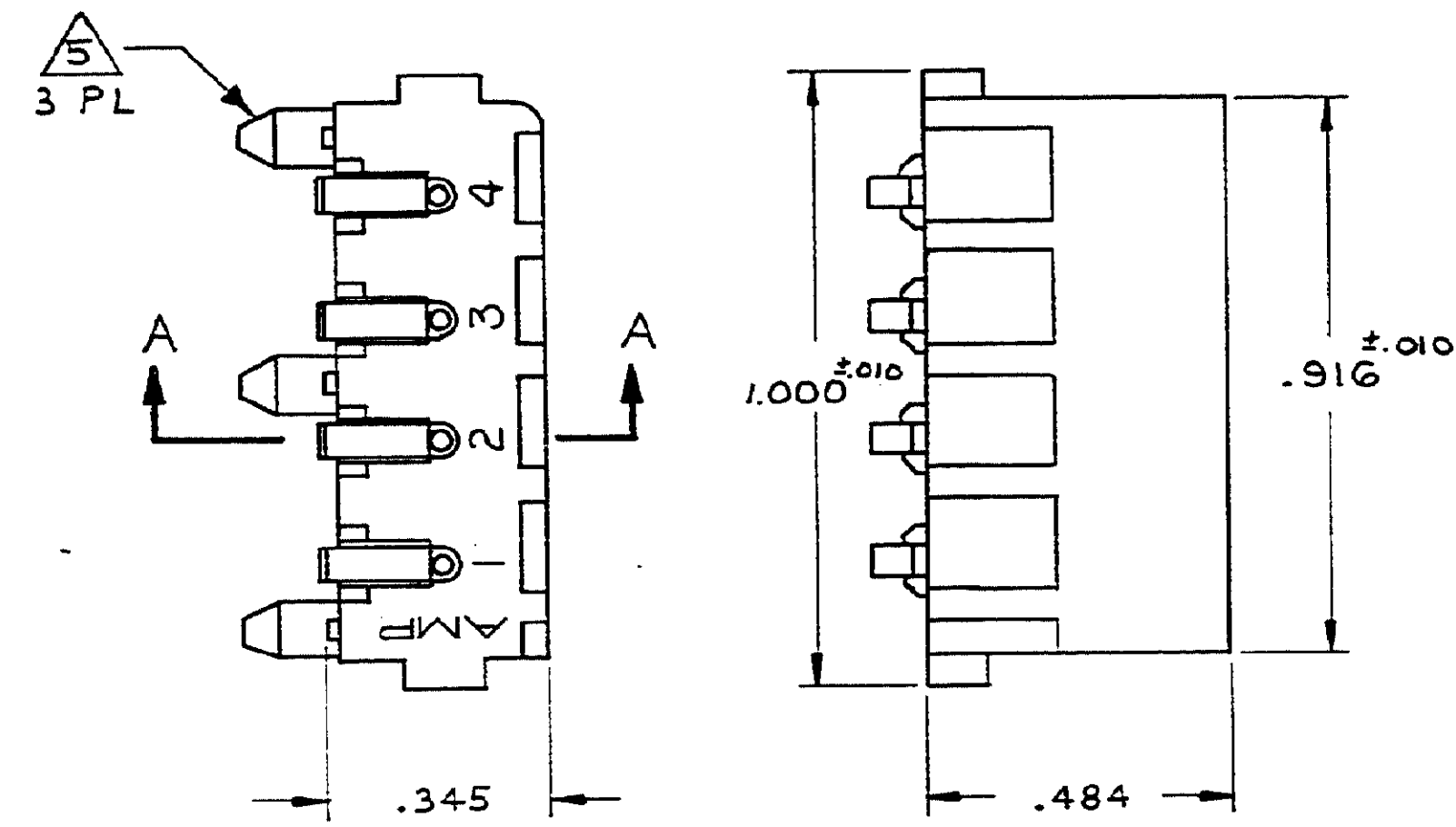
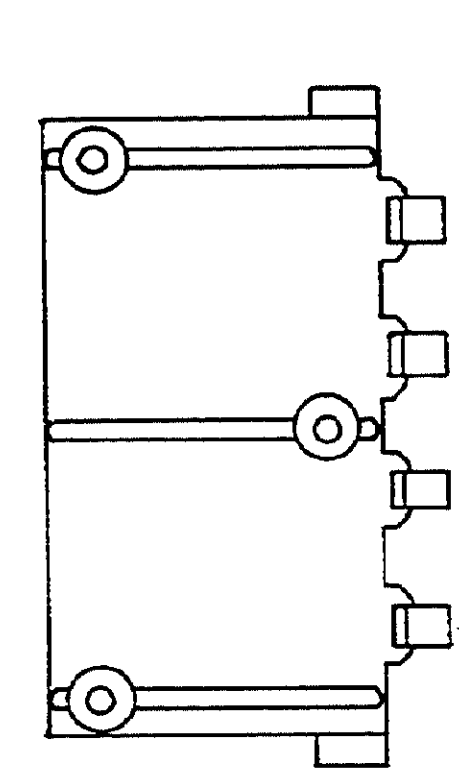

- PARTS COMPLY WITH AMP SOLDERABILITY SPEC 109-11-3.
  - RECOMMENDED EXPOSURE TO VAPOR PHASE REFLOW SOLDERING NOT TO EXCEED 3 MIN.
- ⚠ MATERIAL-HOUSING: NYLON, UL94V-2 (NATURAL)  
CONTACT: PH BRZ (PRE-TIN).
  - ⚠ .010 MIN THICK SOLDER PASTE, 63/37 TIN-LEAD.
  - ⚠ PINS TO BE HEAT STAKED TO RETAIN CONNECTOR TO BOARD

770149-1 SHOWN

UNLESS OTHERWISE SPECIFIED DIMENSIONS ARE IN INCHES. TOLERANCES ON: DECIMALS = .005 ANGLES =		CONTRACT NO	AMP INCORPORATED Harrisburg, Pa. 17105	
MATERIAL		DR T Beck 6/12/85	NAME PIN HEADER ASSEMBLY, RIGHT ANGLE MOUNT, 4 CKT, COMMERCIAL MATE-N-LOK	
FINISH		CHK 6-13-85	SIZE D	FSCM NO 00779
		APPR 7-16-85	DRAWING NO 770149	SHEET
		OTHER APPR	SCALE 4:1	

CUSTOMER DRAWING