

**GLASS PASSIVATED
BRIDGE RECTIFIERS**

REVERSE VOLTAGE - 50 to 1000Volts
FORWARD CURRENT - 15/25/35/50Amperes

FEATURES

- Surge overload -300~450 amperes peak
- Low forward voltage drop
- Mounting position :Any
- Electrically isolated base-2000 Volts
- Materials used carries U/L recognition

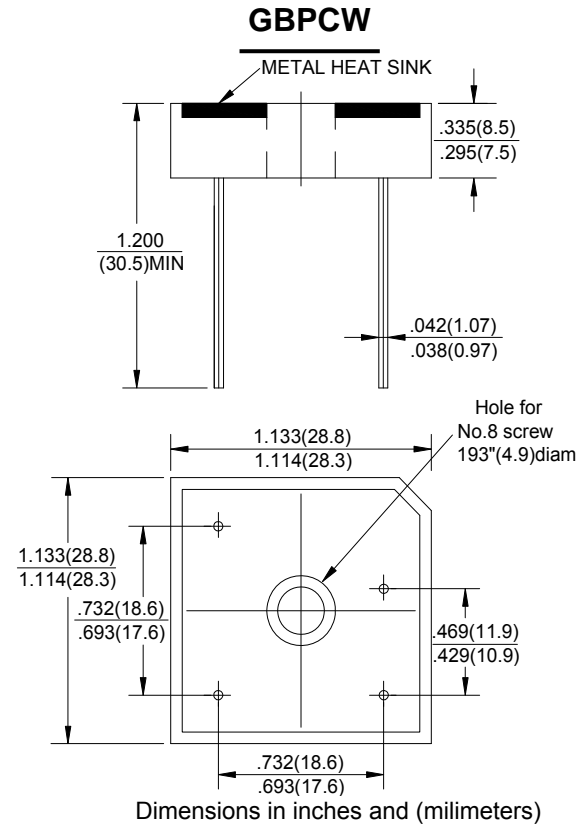

MAXIMUM RATINGS AND ELECTRICAL CHARACTERISTICS

Rating at 25°C ambient temperature unless otherwise specified.

Single phase, half wave ,60Hz, resistive or inductive load.

For capacitive load, derate current by 20%

| CHARACTERISTICS | SYMBOL | GBPC-W | GBPC-W | GBPC-W | GBPC-W | GBPC-W | GBPC-W | GBPC-W | UNIT | |
|-----------------------------------------------------------------------------------------|-------------------|-------------|--------|----------|--------|----------|--------|----------|------|---|
| | | 15005 | 1501 | 1502 | 1504 | 1506 | 1508 | 1510 | | |
| | | 25005 | 2501 | 2502 | 2504 | 2506 | 2508 | 2510 | | |
| | | 35005 | 3501 | 3502 | 3504 | 3506 | 3508 | 3510 | | |
| | | 50005 | 5001 | 5002 | 5004 | 5006 | 5008 | 5010 | | |
| Maximum Recurrent Peak Reverse Voltage | V _{RRM} | 50 | 100 | 200 | 400 | 600 | 800 | 1000 | v | |
| Maximum RMS Bridge Input Voltage | V _{RMS} | 35 | 70 | 140 | 280 | 420 | 560 | 700 | v | |
| Maximum Average Forward Rectified Output Current @ T _c =55°C | I _(AV) | GBPC 15W | 15 | GBPC 25W | 25 | GBPC 35W | 35 | GBPC 50W | 50 | A |
| Peak Forward Surge Current 8.3ms Single Half Sine-Wave Super Imposed on Rated Load | I _{FSM} | 15W | 300 | 25W | 350 | 35W | 400 | 50W | 450 | A |
| Maximum Forward Voltage Drop Per Element at 7.5/12.5/17.5 /25.0A Peak | V _F | 1.1 | | | | | | | v | |
| Maximum Reverse Current at Rated DC Blocking Voltage Per Element @ T _J =25°C | I _R | 10 | | | | | | | µA | |
| Operating Temperature Range | T _J | -55 to +150 | | | | | | | °C | |
| Storage Temperature Range | T _{STG} | -55 to +150 | | | | | | | °C | |

RATING AND CHARACTERISTIC CURVES

GBPC15/25/35/50W SERIES



FIG.1-MAXIMUM FORWARD SURGE CURRENT

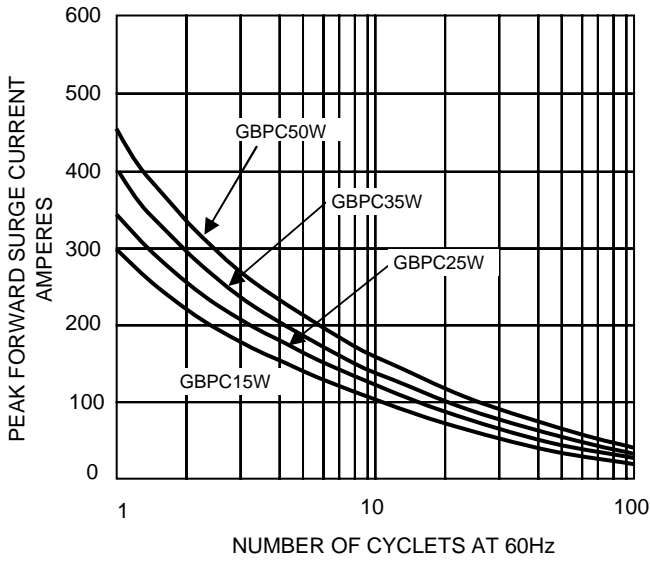

FIG.2- DERATING CURVE OUTPUT RECTIFIED CURRENT

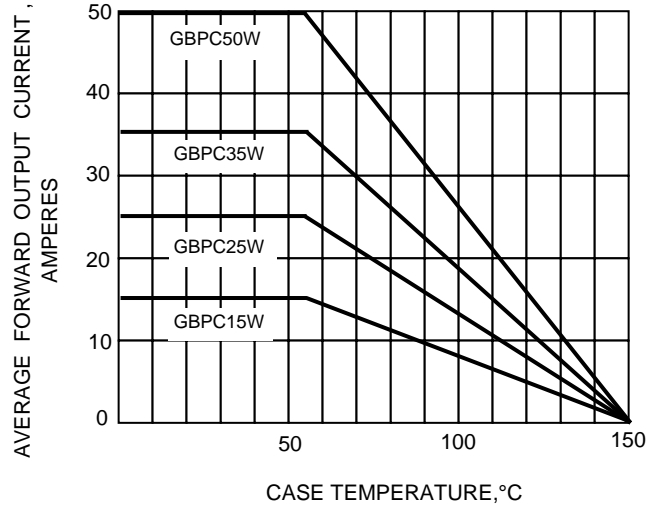

FIG.3-TYPICAL FORWARD CHARACTERISTICS

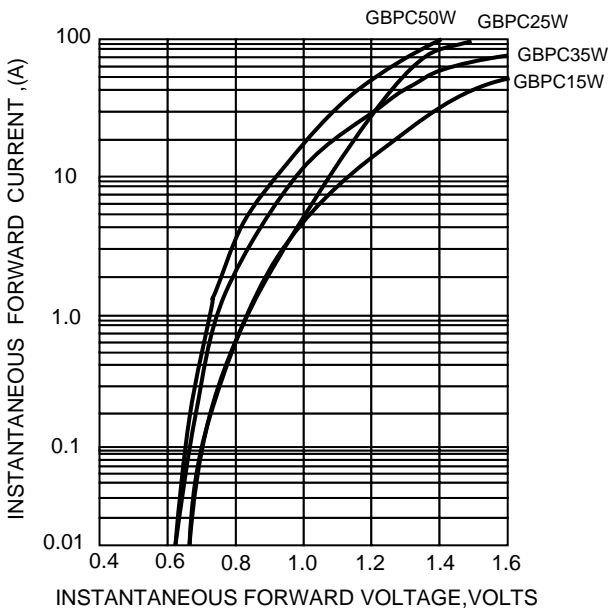
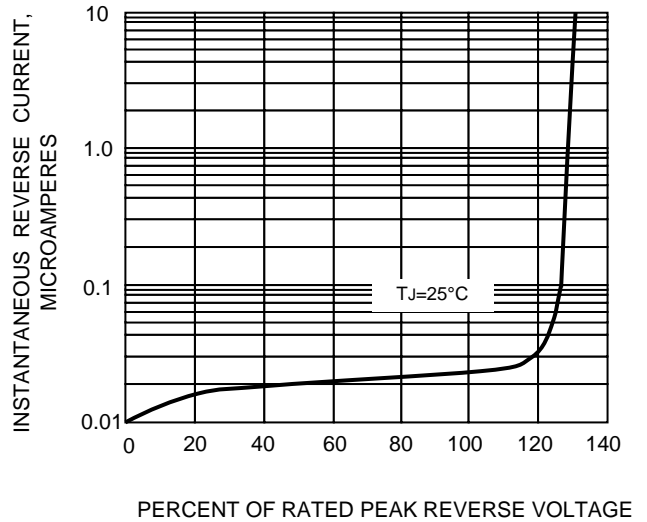

FIG.4-TYPICAL REVERSE CHARACTERISTICS



The cruve graph is for reference only, can't be the basis for judgment(曲线图仅供参考)!