

PROGRAMMABLE LOGIC CONTROLLERS

FX Positioning Family

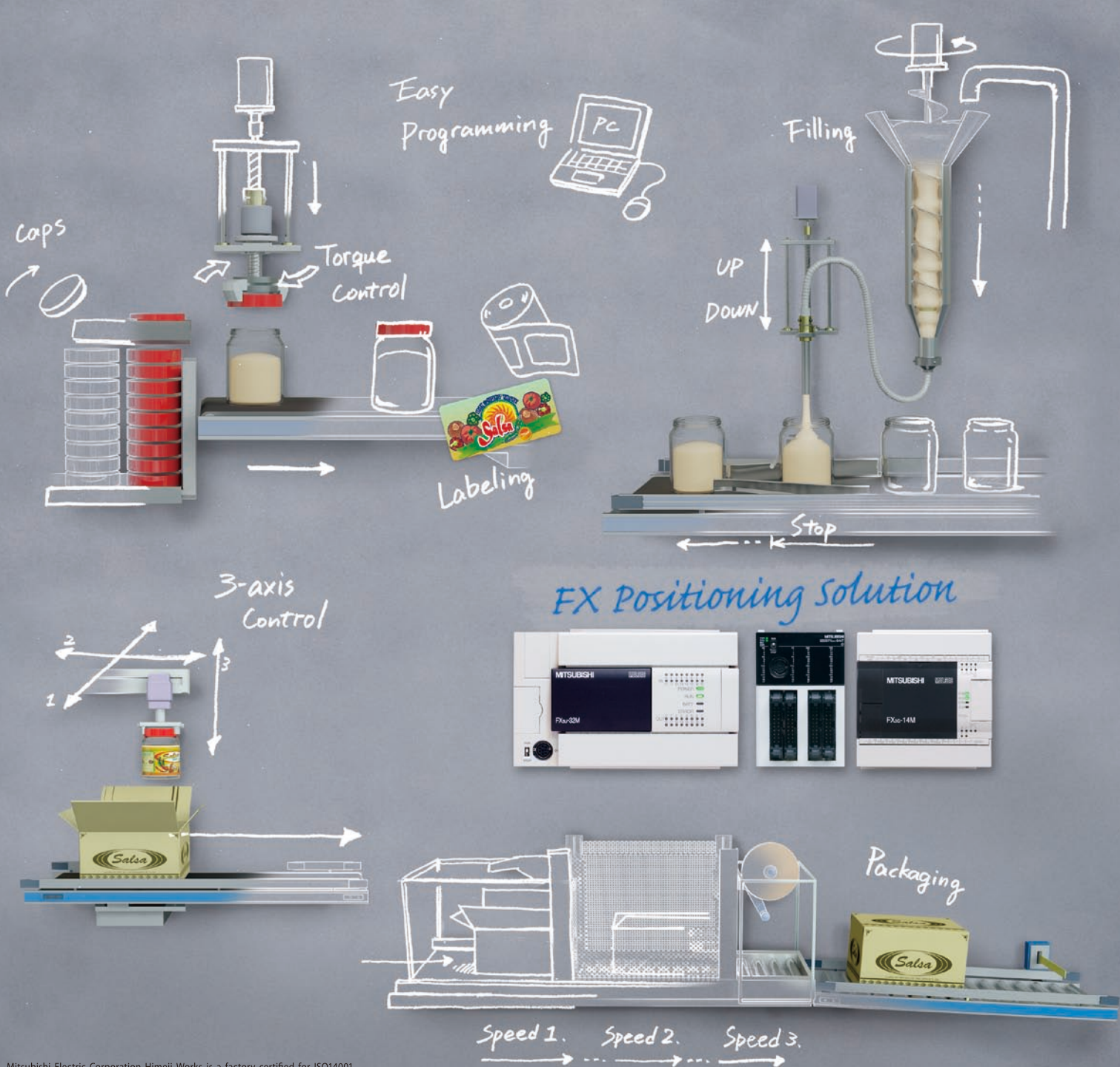

Mitsubishi Electric Corporation Himeji Works is a factory certified for ISO14001 (standards for environmental management systems) and ISO9001(standards for quality assurance management systems)



Empowering Industries

A tradition
in refining
excellence.



Ease of use

Control systems that require minimum setup and keep program development time to a minimum.



Flexible

A configurable design that permits open communication, large I/O handling, as well as precise positioning and analog control, creating systems that mold to customer requirements.



Affordable

A high performance to cost ratio makes economical design solutions for a diverse range of applications a reality. These features combined with Mitsubishi Electric's legacy in quality and reliability ensures that the 3rd generation of controller will continue to be at the forefront of the compact PLC market and provide customers with a leading edge.

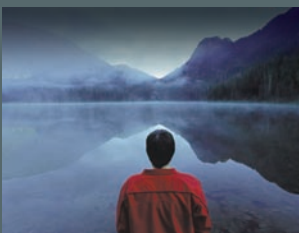

Customer Confidence

With a design philosophy spanning more than quarter of a century, a customer base spread across the globe, a host of industrial certifications and almost 9 million CPUs sold, the FX3 series continues to sustain its position as the compact PLC of choice.

FX3 series The bench

Built-in high-speed pulse outputs and easy to use special instructions for complete positioning tasks enable all FX series main units with transistor outputs to control up to 3 independent axes of servo motion from the main unit itself. Through use of special adapters or function blocks, positioning functions can be further expanded. The available options ranges from single additional axis up to interpolated and networked servo control solutions.

In addition to complete positioning control FX family PLCs incorporate 6 to 8 high speed counters in each model. Thanks to this the FX family is perfectly suited for applications in need of pulse-catch functions, closed-loop feedback processing, or high-speed sensor use.

FX3G filling application

Practical example of a FX3G in a food packaging machine. The PLC senses the position of the can, stops the conveyor and doses the exact amount of the beverage via the worm screw. For accelerating the filling process and ensuring that no air bubbles are enclosed, the filling tube is inserted then drawn out of the can during filling operation.

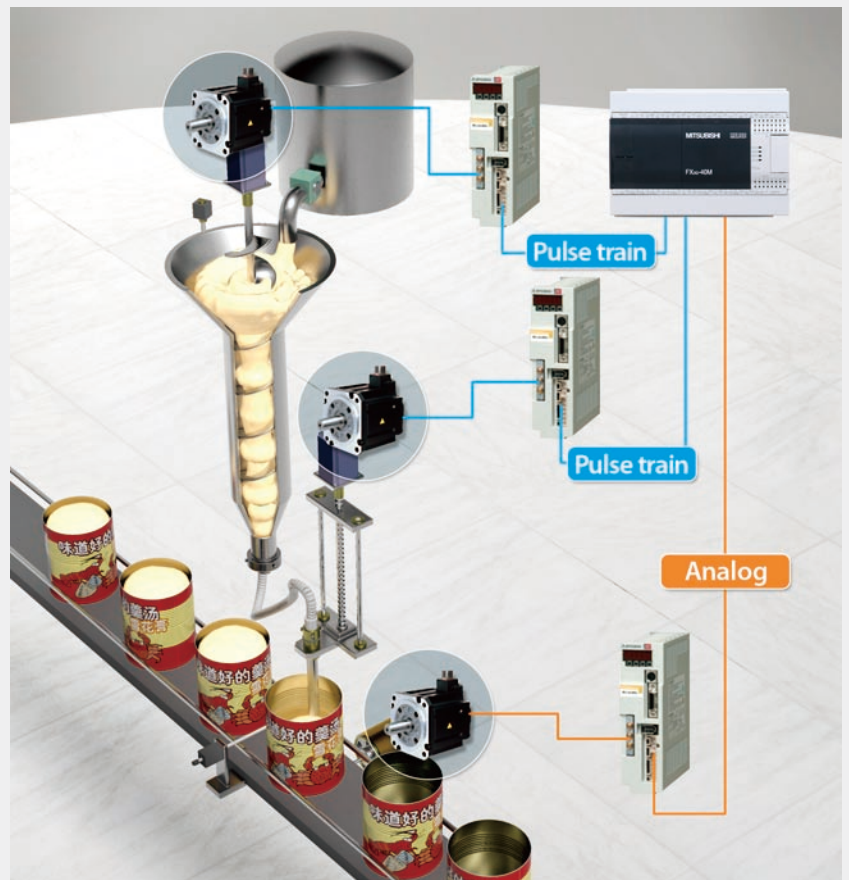

Standards and International Acceptance

Compliance with CE and UL/cUL standards enables users worldwide to put faith in the FX brand. The FX range is also certified to a variety of shipping approvals that include Lloyds, German Lloyds, American Bureau of Shipping, Registro Italiano Navale, DET Norse Veritas, Bureau Veritas and Nippon Kaiji Kyokai.



mark in Positioning Control

Basic positioning

Embedded high-speed outputs in all FX PLC main units allow user friendly positioning control via pulse trains. The wide range of special application oriented positioning commands allows straight forward programming. To keep programming time at a minimum all positioning commands make use of the axis parameters stored in special D registers. Programming the *FX3 series* is even easier as all parameters are conveniently setup via a dedicated parameters window. Using this, positioning instructions can be defined in a table, enhancing the readability and maintainability of the PLC code.

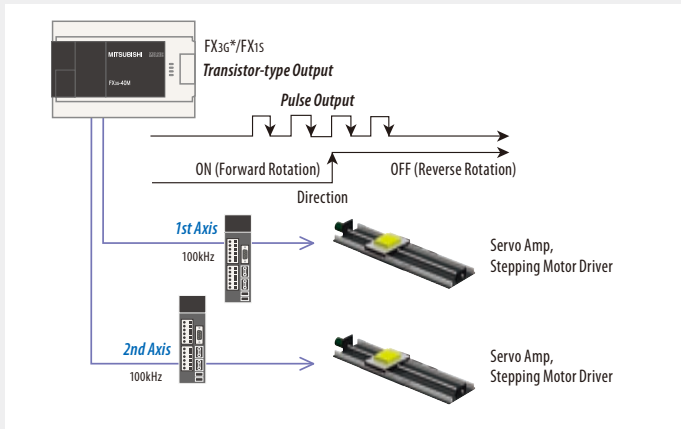

* : The FX3G 40 and 60 I/O points version features 3 axes positioning.

Advanced positioning

Expanding the FX3U and FX3UC with various pulse train output units gives them the ability to overcome advanced application challenges when more axes or a higher frequency is required. Adding up to two pulse train out output adapters to the FX3U main does not require different programming then with the integrated high speed outputs, but supports a higher frequency and up to 4 differential line driver outputs. Expand the main unit with 1 to 8 FX2N-1PG-E or FX2N-10PG special function blocks to add 1 to 8 additional pulse train outputs.

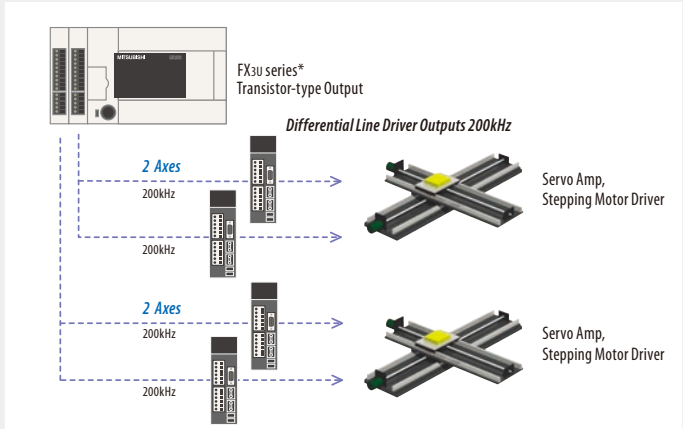

* : FX3U built-in axes are not available when the High-Speed Output ADPs are attached.

Ultra positioning

Combining the most advanced positioning network with the most sophisticated compact PLC lets you build tomorrow's solution today. The special function block for SSCNET III connects the FX3U and FX3UC series to all advantages of the MR-J3 series servo system. Easy wiring with plug and play fiber optic wiring features an easy, fast and noise immune communication to the connect servo amplifiers. Setup of the servo amplifiers is managed centrally within the FX Configurator-FP software which is also used to define all positioning movements. Having the possibility of real time monitoring of the servo status brings maintenance and troubleshooting to a new level of refinement.

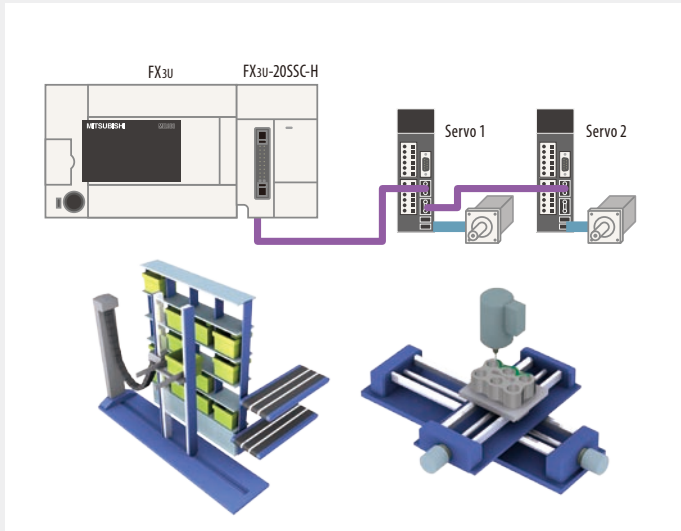

Alternative positioning

All *FX3 series* PLCs offer control of the MR-J3 CC-Link enabled servo amplifier. In this case the amplifier contains a table with various movements which is initiated via the FX2N-16CCL-M unit. This allows the customer to control servos far away from the control location.

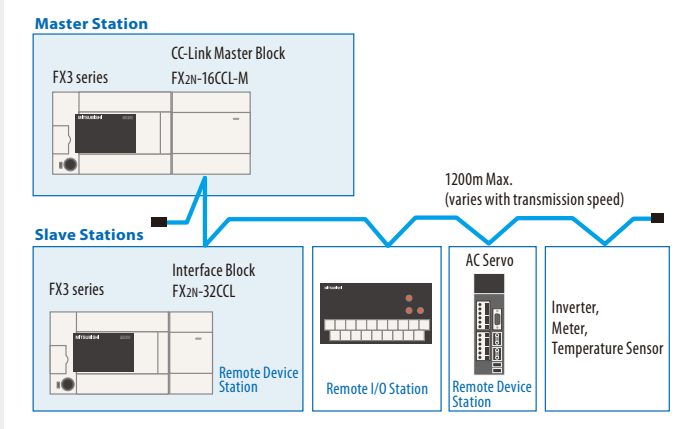

Another option to control servos is to use analog output expansion options. Control using analog signals allows setting the speed or torque of the motor. This makes this setup suitable for those applications in which speed or torque has to be smoothly controlled.

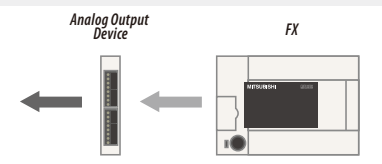

Basic positioning solutions can be effectively managed within a standard FX PLC via pulse train control.

FX series main units



FX3U

TOP OF THE LINE The FX3U is the original dual system-bus, high-speed, fully expandable compact PLC designed to seamlessly control communication, networking, analog and positioning systems.

The combination of 8 high speed inputs, 3 embedded high speed outputs and a full set of positioning instructions lets it challenge applications where previously special controllers were applied to.



FX3UC

SLIM FIT The FX3UC is the ultra-compact high speed, fully expandable PLC. Designed around 24V DC power and using connector-type transistor I/O, the FX3UC is designed for space conscious and modular applications. The same embedded functions of the FX3U but with a much smaller footprint plus special function blocks for positioning control makes the FX3UC the perfect PLC for space and performance critical applications.



FX3G

REACH OUT The FX3G is an introductory compact PLC and is the newest addition to the FX3 series, designed for simple yet performance-critical applications.

2 or 3 high speed outputs combined with 6 high speed inputs with all basic positioning instructions makes the FX3G the a complete all-around PLC.



FX1S

KEEPING IT SIMPLE The FX1S is the fit-and-forget PLC solution for space and cost conscious applications requiring up to 30 I/O.

This minimum-expandability, battery-less maintenance free controller is the optimal solution for simple applications requiring up to 2 high speed outputs and 6 high speed inputs.

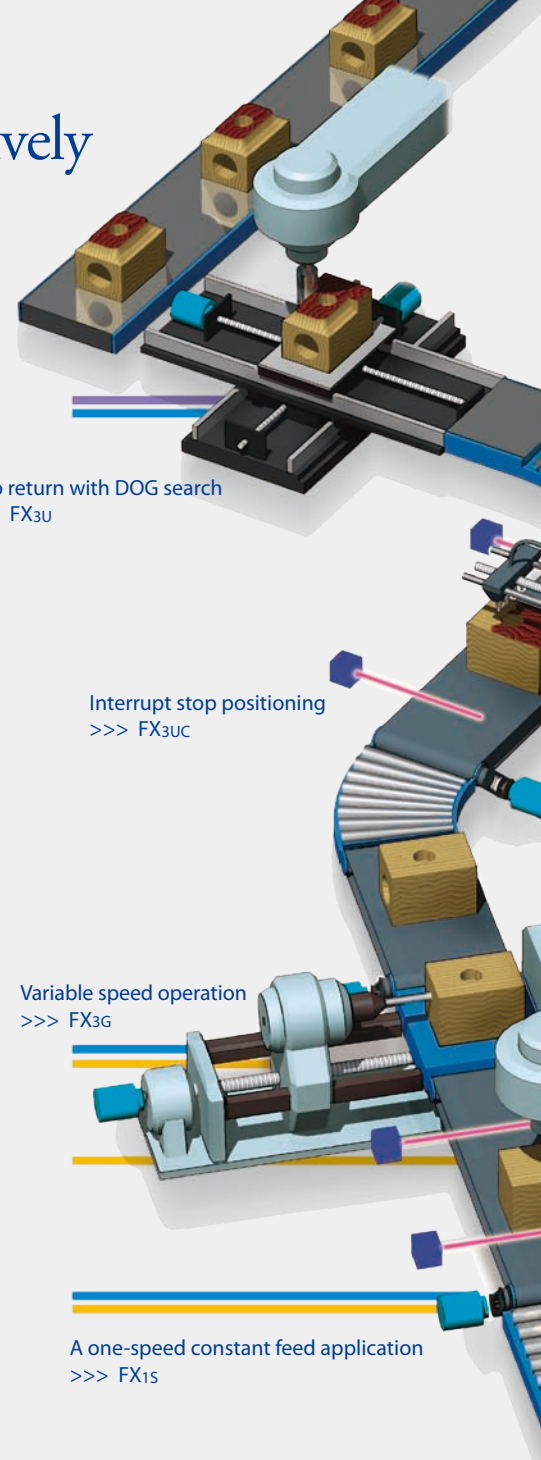

Zero return with DOG search
>>> FX3U

Interrupt stop positioning
>>> FX3UC

Variable speed operation
>>> FX3G

A one-speed constant feed application
>>> FX1S

The embedded high speed inputs of all FX PLCs can be applied for various pulse input functions like high speed counters, frequency measurement or high speed comparison. Additionally real time response input interrupts, pulse catch, and input filter adjustment are available as well. Depending on the main unit type, up to 8 high speed inputs with up to 100 kHz are available to solve all kinds of time-critical tasks.

High speed counting and comparison

High speed counting and high speed comparison is a growing requirement for various industries, like round table applications in blow molding machines which require a precise and high speed response. The FX3U(C) delivers a dedicated instruction to meet this demanding task. HSCT instructions connect a user defined data table of positions and output pattern with a high-speed counter. The maximum comparison speed of 80kHz provides ample performance for all-around table applications.

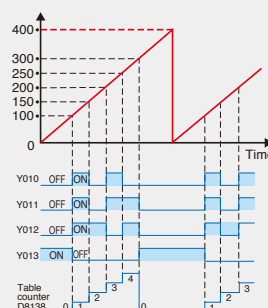

Interrupt handling

Interrupting the PLC program for ultimate process response is the primary function for the using interrupts. By combining interrupt characteristics and positioning functionality, positioning challenges like stretching films become an issue of the past. The FX3U(C) features a dedicated command which uses both a 5µsec interrupt and a 100kHz high speed output. The DVIT function is the solution for all feeding applications.

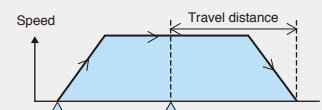

Advanced positioning solutions precisely solved by expansion options

Adapter and Special Function Blocks

FX3U-2HSY-ADP

The high speed output adapter

This high speed output adapter can be used on the left side of the FX3U main units. Therefore the integrated outputs of the PLC main unit are rerouted to the adapter making program changes unnecessary. All commands of the FX3U are supported and with the usage of two adapters, the number of pulse train outputs controlled directly by the PLC main units increases to 4. Additionally the maximum frequency is increased to 200 kHz for more dynamic and precise operations. Having differential line driver outputs makes wiring easier and more resilient to noise.

One of the most common applications is to use together with larger relay output main units, which naturally does not support high speed outputs.



Variable speed operation >>>
FX3U-2HSY-ADP

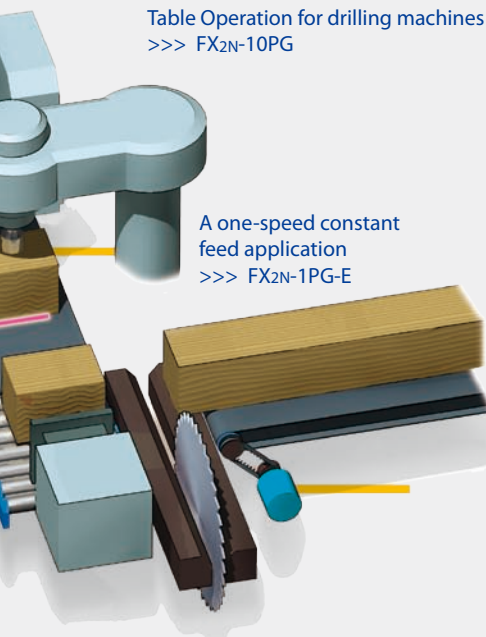

Table Operation for drilling machines
>>> FX2N-10PG

A one-speed constant
feed application
>>> FX2N-1PG-E

FX2N-10PG

The high performance pulse train output special function block

This high performance pulse train output special function block for the right side of the FX3U and FX3UC provides a 1 MHz differential line driver output for high dynamical and very precise applications. With embedded advanced functionality like pulse generator input operation or interrupt two speed positioning users are supplied with ready-made sophisticated functions to solve demanding tasks.

The table operation function makes complete positioning CAMs possible without stopping and waiting for the PLC to start the next positioning command.



FX2N-1PG-E

The basic pulse train output special function block

The basic pulse train output special function block for the right side of the FX3U and FX3UC incorporates a 100 kHz output for a variety of positioning functions. As with all special function blocks once a process e.g. interrupt positioning is started, the unit will execute it independently from the main unit.

Direct wiring of the output and input signals makes commissioning easy. With the maximum number of 8 connectable special function blocks to one PLC main unit, up to 8 independent outputs can be added to the PLC main unit.



Higher precision thanks to more speed and independent counting.

FX3U-4HSX-ADP

Being mounted on the left side of a FX3U main unit, this adapter reroutes the internal high speed inputs for a higher counting speed. By utilizing a differential line receiver easier wiring and better noise protection is achieved. The 4 high speed inputs of the adapter support up to 200 kHz per channel. When using 2 adapters the FX3U can make use of 8 x 200 kHz inputs for all kinds of input signals from single phase counting up to 4 phase counting. Naturally, all other FX3U functions like high speed feed comparison or cam switching are supported as well.



FX3U-2HC and FX2N(C)-1HC

These high speed counter special function blocks are designed for extending the number of high speed counters of the FX3U and FX3UC PLCs. The FX3U-2HC module count 1- or 2-phase pulses up to a frequency of 200 kHz using 16 or 32 bits, the FX2N-1HC and FX2NC-1HC supports frequencies up to 50 kHz. The integrated transistor outputs can be switched independently of one another by means of internal comparison functions. Hence, simple positioning tasks can also be handled economically. In addition, all modules can be used as a ring counter.

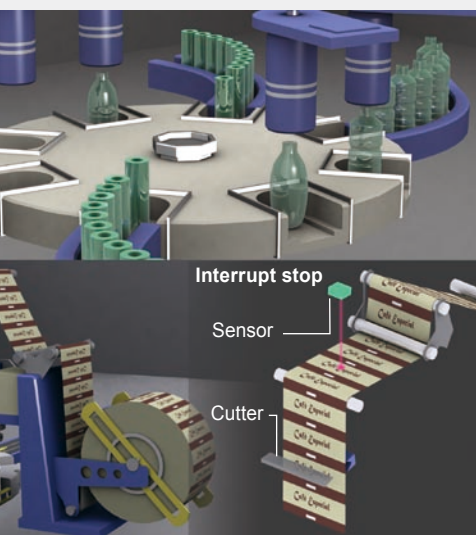

Interrupt stop

Sensor

Cutter

FX3 series with Ultra Positioning Solution.

SSCNET III Offers NEW Advantages

Smooth, high speed, high accuracy operations are now attainable with the new generation SSCNET III synchronous communication network.

Plug-and-Play Fiber Optic Wiring

Cabling setup time is reduced with direct, Plug-and-Play connectivity to servo equipment. Absolute system control eliminates the need for re-wiring, and advanced synchronous control on SSCNET III is achievable for distances up to 50 m (FX3U-20SSC-H to servo Amplifier). Additionally, fiber optic wiring enhances data transfer reliability, improves noise resistance and simplifies wiring diagrams.

High Speed with High Accuracy

Smooth control with high speed serial communication cycle times up to 1.7ms improve positioning accuracy. Synchronous control on high-performance devices is realized with 50 Mbps communication speed.

Short communication cycle

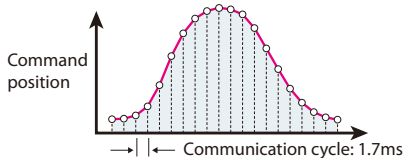

FX3U-20SSC-H

SSCNET III fiber optic high speed, Plug-and-Play wiring with improved noise resistance and long-distance capability enhances positioning control.



FX3U Series PLC



100 kHz Manual Pulsar Input
Up to 2 manual pulsar dials can be connected to generate input pulses for simultaneous ratio operation.

Fiber Optic Cable,
Noise Reduction,
Max. 50m

The Easy Programming Software for Parameter Setting, Monitoring, and Testing

FX Configurator-FP

FX Configurator-FP is useful for setting up table operation information, servo amplifier parameters, and positioning parameters for the FX3U-20SSC-H. Positioning operations and their associated parameters (speeds, addresses, torque limits, etc.) can be monitored and tested with the Monitor and Test functions.



With the new Table Operation feature, program development time is reduced.

Control patterns from simple to complicated combinations of positioning commands can easily be configured with new methods. (Communication is possible with the FX3U-20SSC-H buffer memory or with the FX Configurator-FP software.)

No.	Command code	Address x [PLS] y [PLS]	Speed v [Hz] fr [Hz]	Arc center i [PLS] j [PLS]	Arc radius r [PLS]	Time [10ms]	Jump No.	m code
0								
1	Circular interpolation (CNT, CW)	x: 17000000 y: 17000000	fr: 13100000	i: 120000 j: 120000				-1
2	XY-axis positioning at 1-step speed	x: 8000000 y: 8000000	fr: 300000					-1
3	Circular interpolation (CNT, CCW)	x: 14000000 y: 14000000	fr: 500000	i: 120000 j: 120000				-1
4	Linear interpolation	x: 80000000 y: 140000000	fr: 20000000					-1
5	X-axis present address changing	x: 80000000						-1

FX Configurator-FP GX Developer

- FX3U-20SSC-H positioning parameters
- MR-J3-B servo amplifier parameters
- Table operation information
- Monitor/Control data



High Speed Positioning with High Precision Control

With the high resolution encoder on the MR-J3 servo motor, pulses may be counted for rates up to 262,144 pulses/rev. Performance is enhanced for stable control in low speed regions where precision is essential.

2 Axes for Advanced Operation Control

High precision control on 2 axes with synchronous capability via SSCNET III optical wiring is available.

Storage and Sorting

Independent 2 axes for product placement.

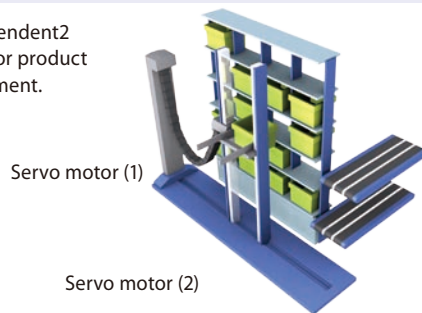

Drilling and Sealing

Linear/Circular interpolation for table operations.

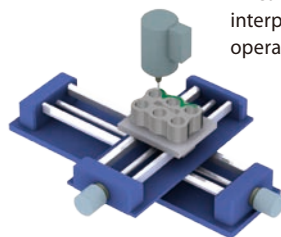

The operation speed and target position can change during positioning for more flexibility in positioning applications.

Variable Speed Operation

Operation speeds change to user-specified speeds according to arbitrary timing intervals.

Override Function

To change the operation speed at an arbitrary timing during positioning, the override function may be used for amplifying the signal from 0.1% to 3000%.

Target Address Change

The target address may be changed to a new location during a positioning operation.

3 Settings for Zero Return Method

Various modes are available for setting a workpiece's mechanical zero return method including Dog type zero return, Data-type zero return, and Stopper type zero return.

DOG Type Mechanical Zero Return

When a workpiece stops with a DOG type mechanical zero return, the zero-point position is set.

Stopper Type Mechanical Zero Return

A workpiece stops at the stopper position according to the zero return torque limit value and a new zero-point is defined.

Data-set Type Mechanical Zero Return

For operations without a mechanical zero-point or DOG return, the Data-set Type Mechanical Zero Return procedure is convenient for setting the zero-point of a workpiece.

Inching Operation

A pulse string of ± 1 (user unit) is output when the forward/reverse rotation JOG activation time is less than the user defined JOG command determination time

Torque Limit Change

The torque limit for stopping the servo motor when a workpiece hits a mechanical stopper can be changed with a sequence program. Depending on the mass of the device being controlled in a goods processing application, for example, the torque limit parameter can be adjusted accordingly.

Central Networking Management

From one location, large volumes of data can be monitored and effectively managed in real-time. Positioning addresses, speeds and servo amplifier parameters are displayed for diagnostic monitoring and testing during data transfer between the controller (FX3U-20SSC-H) and servo amplifier.

Max. of 8 units

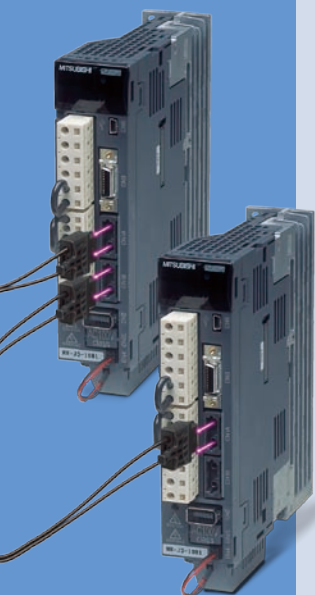

MR-J3 servo

FX Series Servo Control System

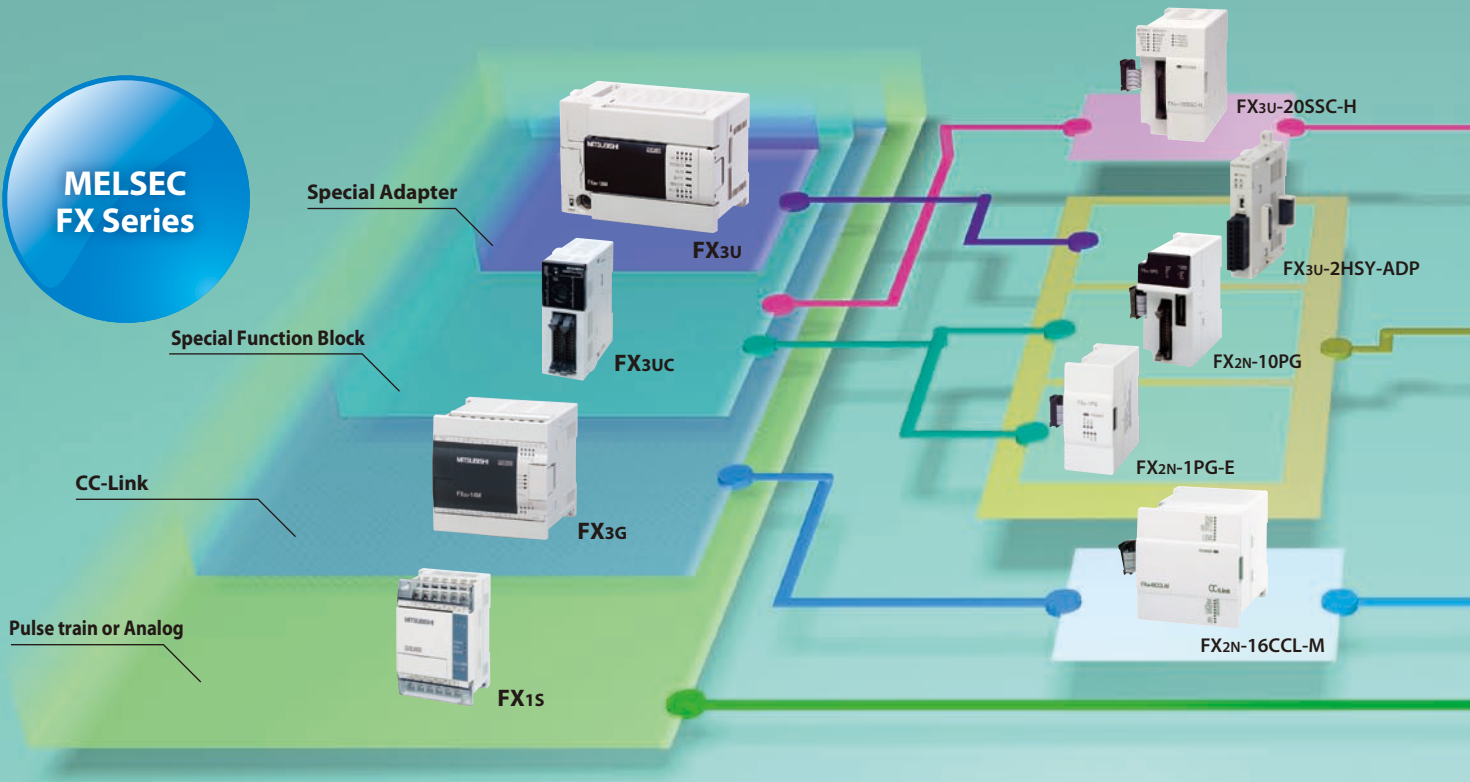

Positioning Instructions

Jog operation

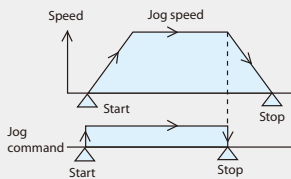

At START, the JOG operation begins. The machine decelerates to STOP when the JOG command is disabled.

20SSC-H FX3U* FX3UC FX3G* FX1s* 1PG-E/10PG

* Drive and stop the one-speed positioning instruction for this functionality.

Zero return - Mechanical

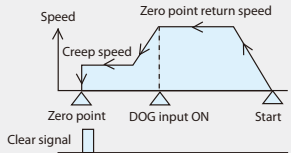

The machine moves at return speed toward the zero point. When the DOG input is triggered, the machine returns to the DOG position momentarily and proceeds to zero at creep speed.

20SSC-H FX3U* FX3UC FX3G* FX1s* 1PG-E/10PG

*Use DSR for FX3U/FX3G and ZRN for FX1s.

One-speed positioning

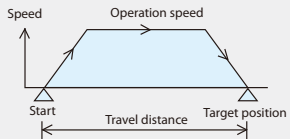

The axis is positioned at the specified operation speed. Two independent axes are available for the FX2N-20GM.

20SSC-H FX3U* FX3UC FX3G* FX1s* 1PG-E/10PG

* Use DRV1 or DRVA (Use One-speed positioning instruction).

Two-speed positioning

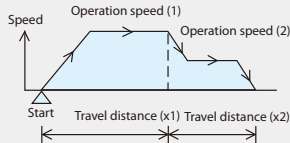

At START, the machine moves to position, X1, at Speed (1), then moves to position, X2, at Speed (2).

20SSC-H 1PG-E/10PG

Variable speed operation

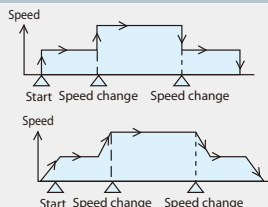

At START, this operation outputs pulses at a designated frequency. The frequency can be changed several times during the operation.

20SSC-H FX3U*1 FX3UC FX3G*1 *1*2 1PG-E*2/10PG

*1 Use PLSV
*2 Acceleration to different speeds is approximated with the RAMP instruction

Multi-speed operation

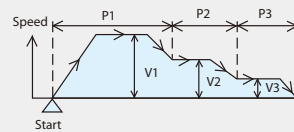

At START, the machine moves to consecutively to positions (P1/P2/P3) at the respective operation speeds (V1/V2/V3) without stopping.

20SSC-H 10PG

Interrupt stop

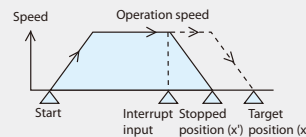

If an interrupt is received during a positioning operation, the machine will decelerate and stop immediately (x).

20SSC-H 10PG

Interrupt one-speed positioning

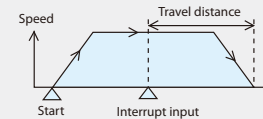

At START, the machine moves at the operation speed. When the interrupt input is received the machine moves to the specified position and stops.

20SSC-H FX3U* FX3UC 1PG-E/10PG

*Use DVIT

Interrupt two speed positioning (1)

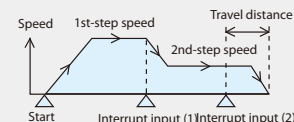

At START, the machine moves at the operation speed. When the interrupt input is received, the machine decelerates to the second speed. When the second interrupt input is received, the machine travels to the target position, decelerates and stops.

20SSC-H 10PG

Interrupt two speed positioning (2)

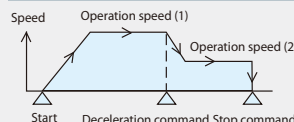

In the FX2N-1PG-E variation of this instructions, the machine will stop immediately at the second interrupt. This operation is also known as External Command Positioning Operation.

1PG-E



MELSERVO J3 series

The ever-evolving new generation of servos

Mitsubishi Servo Line Up

HF series

- HF-KP 50W to 750W Low inertia
- HF-MP 50W to 750W Ultra-low inertia
- HF-SP 500W to 7kW Medium inertia
- HF-JP 500W to 15kW Low inertia

HC series

- HC-RP 1kW to 5kW Ultra-low inertia
- HC-LP 500W to 3kW Low inertia
- HC-UP 750W to 5kW Flat type

HA series

- HA-LP 5kW to 55kW Low inertia

MR-E-A (Puls train)

MR-E-AG (Analog)

HF series

- HF-KE 100W to 750W Low inertia
- HF-SE 500W to 2kW Medium inertia

MELSERVO MR-E Super series

User-friendly servos with easy operation

Linear interpolation

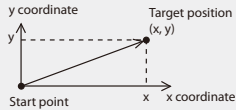

The machine moves to a specified target position at a specified vector speed. Consecutive targets can be reached without stopping (continuous pass operation).

20SSC-H

Circular interpolation

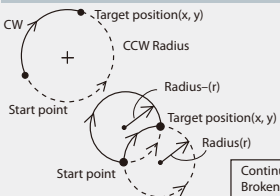

The machine moves to a specified target position at a specified peripheral speed. Consecutive targets can be reached without stopping (continuous pass operation).

20SSC-H

Manual Pulse Generator

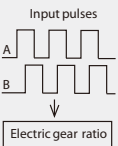
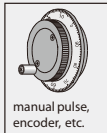

A manual pulse generator can be connected to generate pulses manually. Simultaneous ratio operation using the manual pulse generator, encoder, etc. is possible. Maximum frequency for input pulses.

FX3U-20SSC-H: Max. 100kHz
FX2N-10PG: Max. 30kHz

20SSC-H

10PG

Absolute Position detection

This instruction reads the absolute position from a servo amplifier equipped with absolute position detection. Occupies 6 I/O (hard-wired).

20SSC-H

*1 FX3U/*2 FX3UC

FX3G

FX1S*2

1PG-E/10PG*1&2

*1 PLC is necessary
*2 Use ABS

Table Operation

No.	Position	Speed
0	200	500	
1	500	1000	
2	1000	2000	

Positions and speeds can be stored in a table format. Max. points: 300/axis (FX3U-20SSC-H) Max. points: 200/axis (FX2N-10PG)

20SSC-H

*1 10PG

*1 Using FX Configurator-PP

DTBL(Batch Data Positioning Mode)

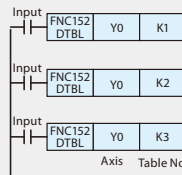

Axis Table No.
Y000 is positioned by the operation in table number 1-3

FX3U

FX3UC

FX3G

This convenient new feature allows for a fast and easy setup of positioning instructions for basic motor control applications. A simple table layout is used to enter machine pulses and frequencies to reduce program code and decrease engineering project time. Programmed positions can be uploaded to GX Developer for back-up and documentation. They can also be copied to a memory cassette attached to a FX3 series PLC.

DTBL example

1. Set basic parameters including the acceleration/deceleration time and creep speed for each axis using GX Developer.
2. Define positioning commands in a table including steps and maximum speed.
3. Call the pre-defined positioning commands in the PLC program using the dedicated instruction (DTBL).
4. Positioning control via the embedded high speed outputs.
5. Change all positioning parameters via the GOT.

Configuration rules/expandability

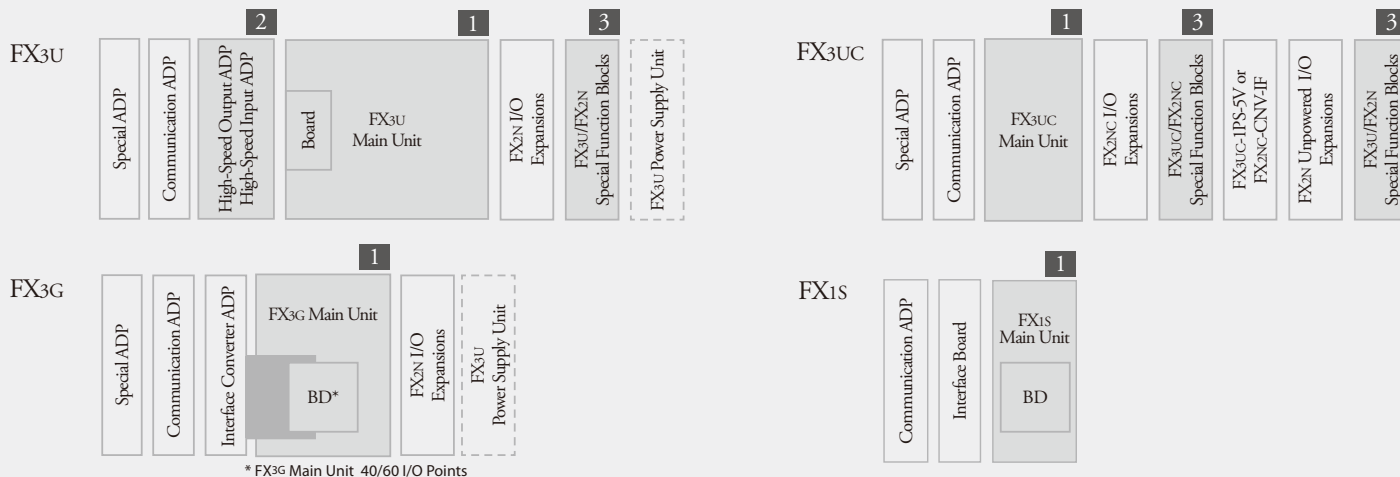

* FX3G Main Unit 40/60 I/O Points

1 FX3U Main Units 16-128 I/O

FX3U-16M[] T/ES: AC D2 T1
 FX3U-32M[] T/ESS: AC D2 T2
 FX3U-48M[] R/ES: AC D2 R
 FX3U-64M[] T/D/S: DC D2 T1
 FX3U-80M[] T/DSS: DC D2 T2
 FX3U-128M[] R/D/S: DC D2 R

1 FX3UC Main Units 16-96 I/O

FX3UC-16MT[]
 FX3UC-32MT[]
 FX3UC-64MT[]
 FX3UC-96MT[]
 D: DC D1 T1
 DSS: DC D2 T2

1 FX3G Main Units 14-60 I/O

FX3G-14M[] T/ES: AC D2 T1
 FX3G-24M[] R/ES: AC D2 R
 FX3G-40M[]
 FX3G-60M[] T/D/S: DC D2 T1
 T/DSS: DC D2 T2
 R/D/S: DC D2 R

Note: FX3G DC units are available from Spring 2010.

1 FX1S Main Units 10-30 I/O

FX1S-10M[] R-ES/UL AC D2 R
 FX1S-14M[] T-ESS/UL AC D2 T2
 FX1S-20M[] R-DS DC D2 R
 FX1S-30M[] T-DSS DC D2 T2

2 Special Adapter

Positioning
 FX3U-2HSY-ADP
 High Speed Counter
 FX3U-4HSX-ADP

FX3U-4HSX-ADP
 FX3U-2HSY-ADP

3 Special Function Blocks

Positioning
 FX2N-1PG-E
 FX2N-10PG
 FX3U-20SSC-H
 FX2N-1RM-E-SET

High Speed Counter
 FX2N-1HC
 FX2NC-1HC
 FX3U-2HC*

*This module is available from spring 2010.

- AC AC Power supply
- DC DC Power supply
- D1 DC Input(sink)
- D2 DC Input(sink/source)
- R Relay output
- T1 Transistor(sink)
- T2 Transistor(source)

Group	System Item	FX3U	FX3UC	FX3G	FX1S	Item Specification*1
1 Main Unit	Positioning	★	★	✓	✓	2 100kHz Axis Built-in Positioning
		✓	✓	✓+2		Up to 3 100kHz Axis Built-in Positioning
		✓				Up to 4 200kHz Axis with High-Speed Output Adapters
		✓	✓			Up to 8 1MHz Axis with Special Function Blocks
		✓	✓			Up to 16 SSCNET-III Axis with Special Function Blocks
		✓	✓			Cam switching
	High-Speed Counters	★	★	✓	✓	Up to 6 high speed counter, max 60kHz
		✓	✓			Up to 8 high speed counter, max 100kHz
✓					Up to 8-high speed counter with 200kHz Adapter	
	✓	✓			Additional Expansion using High-Speed Counter Block	

Group	Function	Product Name	FX3U	FX3UC	FX3G	FX1S	Description					
2 Adapter	Positioning	FX3U-2HSY-ADP	✓				Axis	Max. Frequency	Output Type			
	High-Speed Counters						Input	Max. Frequency	Input Type			
		FX3U-4HSX-ADP	✓					4	200kHz	Differential line receiver		
3 Special Function Blocks	Positioning	FX2N-1PG-E	✓	✓+3			Axis	Max. Frequency	Output Type			
		FX2N-10PG	✓	✓+3			1	100kHz	Open collector			
		FX3U-20SSC-H	✓	✓+3			2	SSCNET-III positioning network				
		FX2N-1RM-E-SET	✓	✓+3			1	Electronic cam module				
	High-Speed Counters							Input	Max. Frequency	Output	Output Type	Note
		FX2N-1HC	✓	✓+3				1	50kHz	2	Transistor	-
		FX2NC-1HC		✓				1	50kHz	2	Transistor	-
		FX3U-2HC	✓	✓+3				2	200kHz	4	Transistor	-

✓ : Contains required functionality
 ★ : Higher functionality or more expandability
 * 1 : Some items require additional expansion modules in order to function where other connection rules and requirements may apply. For more details, refer to the respective product manuals.
 * 2 : Only for the 40 and 60 I/O points main units
 * 3 : For the connection to an FX3UC main unit, the FX2NC-CNV-IF interface adapter or the FX3UC-1PS-5V power supply unit is required.

Specifications

Model	FX3U	FX3UC	FX3G	FX1S
Number of controlled axes (independent)	3	3	2*1	2
Number of output points	FX3U-16MT*: 8	FX3UC-16MT*: 8	FX3G-14MT*: 6	FX1S-10MT*: 4
	FX3U-32MT*: 16	FX3UC-32MT*: 16	FX3G-24MT*: 10	FX1S-14MT*: 6
	FX3U-48MT*: 24	FX3UC-64MT*: 32	FX3G-40MT*: 16	FX1S-20MT*: 8
	FX3U-64MT*: 32	FX3UC-96MT*: 48	FX3G-60MT*: 24	FX1S-30MT*: 14
	FX3U-80MT*: 40	–	–	–
FX3U-128MT*: 64	–	–	–	
Pulse output format	Open collector			
Output system	Transistor output (sink or source type available)			
Output method	Pulse train + direction Pulse train + direction			
Output spec.	5 to 30V DC / (0.5A / 1 point)	5 to 30V DC / (0.3A / Y0, Y1, Y2)	5 to 30V DC / (0.5A / 1 point)	5 to 30V DC / (0.5A / 1 point)
	–	0.1A/ Y004 or more	–	–
Response time (ms)	< 0.2ms (< 5µs for Y0-Y2)	< 0.2ms (< 5µs for Y0-Y2)	< 0.2 ms(< 5µs for Y0, Y1)*2	< 0.2ms (< 5µs for Y0, Y1)
Number of input points	FX3U-16MT*: 8	FX3UC-16MT*: 8	FX3G-14MT*: 8	FX1S-10MT*: 6
	FX3U-32MT*: 16	FX3UC-32MT*: 16	FX3G-24MT*: 14	FX1S-14MT*: 8
	FX3U-48MT*: 24	FX3UC-64MT*: 32	FX3G-40MT*: 24	FX1S-20MT*: 12
	FX3U-64MT*: 32	FX3UC-96MT*: 48	FX3G-60MT*: 36	FX1S-30MT*: 16
	FX3U-80MT*: 40	–	–	–
FX3U-128MT*: 64	–	–	–	
Input signal	24V DC	24V DC	24V DC	24V DC
	6mA (24V DC X0 to X5)	6mA (24V DC X0 to X5)	7mA (24V DC X0 to X7)	7mA (24V DC X0 to X7)
	7mA (24V DC X6, X7)	7mA (24V DC X6, X7)	5mA (24V DC X10 or later)	5mA (24V DC X10 or later)
	5mA (24V DC X10 or later)	5mA (24V DC X10 or later)	–	–
Input response time	5µs (X0 to X5)	5µs (X0 to X5)	10µs (X0, X1, X3, X4)	10µs (X0-X1)
	50µs(X6, X7)	50µs(X6, X7)	50µs(X2, X5, X6, X7)	50µs (X02-X5)
	All Inputs Approx. 10 ms	All Inputs Approx. 10 ms	All Inputs Approx. 10 ms	All Inputs Approx. 10 ms

* : ESS/UL or DSS for FX1S, ES, ESS, DS or DSS for FX3U/FX3G,DS or DSS for FX3UC.

* 1 : The 40 and 60 I/O points main units support 3 positioning axis.

* 2 : The 40 and 60 I/O points main units support 5 µs for Y2.

Positioning Units				
Model	FX3U-20SS-H	FX3U-2HSY-ADP	FX2N-10PG	FX2N-1PG-E
Number of controlled axes	2	2	1	1
Number connected to PLCs	8	2	8	8
Pulse frequency	Fiber optical positioning network , 50Mbps full duplex	200kHz	1MHz	100kHz
Output system		differential line driver	differential line driver	open collector
Output method		pulse train + direction / forward/reverse pulse train		
Output specification		25 mA or less	5 to 24V DC / 25mA or less:FP,RP 5 to 24V DC / 20mA or less:CLR	5 to 24V DC / 20mA or less:FP,RP, CLR

High Speed Counter Units				
Model	FX3U-4HSX-ADP	FX2N-1HC	FX2NC-1HC	FX3U-2HC*3
Number of controlled axes	4	1	1	2
Number connected to PLCs	2	8	8	8
Pulse frequency	200kHz	50kHz	50kHz	200kHz
Input system	differential line driver	open collector, differential line driver	open collector, differential line driver	open collector, differential line driver
Input specification	1 edge, 2 edges, 4 edges			

* 3 : This module is available from spring 2010.

Visualization

GRAPHIC OPERATION TERMINAL GOT1000

Industrial control panels are increasingly turning into multifunctional human-machine interfaces.
The GOT1000 family features 3 different series to provide the best fit of functionality for all kind of user requirements

GT16

The all-in-one model

- Multimedia
- Video RGB
- Network
- Backup/restore
- Serial



15-inch XGA TFT
GT1695M 65,536 colors



12.1-inch SVGA TFT
GT1685M 65,536 colors



10.4-inch SVGA VGA TFT
GT1675M 65,536 colors



8.4-inch SVGA VGA TFT
GT1665M 65,536 colors

GT11

Standard functions for demanding users

- Hand health
- Scripting
- Parts movement
- System monitor



5.7-inch QVGA TFT
GT1155 256 colors



QVGA STN
GT1155 256 colors



QVGA STN
GT1150 16 gray scales



QVGA Handy GOT/STN
GT1155HS 256 color
GT1150HS 16 gray scales

GT10

Affordability with basic functionality

- Multi language
- Multi action switch
- Recipe functions



5.7-inch QVGA STN
GT1055 256 colors
GT1050 16 blue scales



4.7-inch QVGA STN
GT1045 256 colors
GT1040 16 blue scales



4.5-inch STN GT1030
Monochrome Tricolor LED
[Green/Orange/Red] [White/Pink/Red]
Black Frame / White Frame



3.7-inch STN GT1020
Monochrome Tricolor LED
[Green/Orange/Red] [White/Pink/Red]
Black Frame / White Frame

Global Partner. Local Friend. Worldwide Mitsubishi Electric Sales Offices

- | | | |
|--|---|--|
| <p>Australia Mitsubishi Electric Australia Pty. Ltd.
348 Victoria Road, Rydalmere, N.S.W 2116, Australia
Tel: +61-2-9684-7777 Fax: +61-2-9684-7245</p> <p>Brazil MELCO-TEC Rep. com.e Assessoria Tecnica Ltda.
Rua Correia Dias, 184, Edificio Paraiso Trade Center-8 ander Paraiso, Sao Paulo, SP Brasil
Tel: +55-11-5511-3146-2200 Fax: +55-11-5511-3146-2217</p> <p>China Mitsubishi Electric Automation (Shanghai) Ltd.
17/F., ChuangXing Financial Center, No.288 West Nanjing Road, Shanghai, 200003, P.R.C
Tel: +86 (21) 2322-3030 Fax: +86 (21) 2322-3000</p> <p>Czech Mitsubishi Electric Europe B.V. - o.s. Czech Branch
Radlická 714/113a 158 00 Praha 5 Czech Republic
Tel: +420 251 551 470 Fax: +420 251 551 471</p> <p>France Mitsubishi Electric Europe B.V. French Branch
25, Boulevard des Bouvets, F-927 41 Nanterre Cedex, France
Tel: +33-1-55 6855 68 Fax: +33-1-55 68 57 57</p> <p>Germany Mitsubishi Electric Europe B.V. German Branch
Gothaer Strasse 8 D-40880 Ratingen, GERMANY
Tel: +49-2102-486-0 Fax: +49-2102-486-1120</p> <p>India Messung Systems Pvt. Ltd.
Electronic Sadan NO:III Unit No15, M.I.D.C. Bhosari, Pune-411026, India
Tel: +91-20-27 12-3130 Fax: +91-20-27 12-8108</p> | <p>Indonesia P.T. Autoteknindo SUMBER MAKMUR
Murara Karang Selatan, Block A/ Utara No.1 Kav. No.11 Kawasan Industri Pergudangan, Jakarta - Utara 14440, P.O. Box 5045 Jakarta, 11050 Indonesia
Tel: +62-21-6630833 Fax: +62-21-66300832</p> <p>Ireland Mitsubishi Electric Europe B.V. Irish Branch
Westgate Business Park, Ballymount IRL-Dublin 24
Tel: + 353 1 / 4198800 Fax: + 353 1 / 4198890</p> <p>Italy Mitsubishi Electric Europe B.V. Italian Branch
Centro Dir. Colleoni, Pal. Perseo-Ingr.2 Via Paracelso 12, I-20041 Agrate Brianza Milano, Italy
Tel: +39-039-6053-1 Fax: +39-039-6053-312</p> <p>Korea Mitsubishi Electric Autoamation Korea Co., Ltd.
1480-6, Gayang-dong, Gangseo-ku Seoul 157 -200, Korea
Tel: +82-2-3660-9552 Fax: +82-2-3664-8372</p> <p>Poland Mitsubishi Electric Europe B.V. Polish Branch
ul. Krakowska 50 32-083 Balice, Poland
Tel: +48 12 630 47 00 Fax: +48 12 630 47 01</p> <p>Russia Mitsubishi Electric Europe B.V.
Moscow Representative Office 52 /5, Kosmodamianskaya. nab., 115054, Moscow, Russia
Tel: +7-812-633-3497 Fax: +8-812-633-3499</p> <p>Singapore Mitsubishi Electric Asia Pte, Ltd.
307 Alexandra Road #05-01/02 Mitsubishi Electric Building, Singapore 1599 43
Tel: +65-6470-2460 Fax: +65-6476-7439</p> | <p>South Africa Circuit Breaker Industries Ltd.
Private Bag 2016, ZA-1600 Isando, South Africa
Tel: +27-11-92 8-2000 Fax: +27-11-392-2354</p> <p>Spain Mitsubishi Electric Europe B.V. Spanish Branch
Carretera de Rubi 76-80, E-08190 Sant Cugat del Valles, Barcelona, Spain
Tel: +34-93-565-3131 Fax: +34-93-589-1579</p> <p>Taiwan Setsuyo Enterprise Co., Ltd.
6F No.105 Wu Kung 3rd RD, Wu-Ku Hsiang, Taipei Hsien, Taiwan
Tel: +886-2-2299-2499 Fax: +886-2-2299-2509</p> <p>Thailand Mitsubishi Electric Automation (Thailand) Co., Ltd.
Bang-Chan Industrial Estate No.111 Moo 4, Serithai Rd, T.Kannayao, A.Kannayao, Bangkok 10230 Thailand
Tel: +66-2-517-1326 Fax: +66-2-517-3239</p> <p>U.K. Mitsubishi Electric Europe B.V. UK Branch
Travellers Lane, Hatfield, Hertfordshire., AL10 8XB, U.K.
Tel: +44-1707-27 6100 Fax: +44-1707-27 8695</p> <p>U.S.A. Mitsubishi Electric Automation, Inc.
500 Corporate Woods Parkway, Vernon Hills, IL60061, U.S.A.
Tel: +1-847-478-2100 Fax: +1-847-478-0327</p> |
|--|---|--|

MITSUBISHI ELECTRIC CORPORATION
 HEAD OFFICE: TOKYO BLDG., 2-7-3, MARUNOUCHI, CHIYODA-KU, TOKYO 100-8310, JAPAN
<http://Global.MitsubishiElectric.com>