



ORIENT DISPLAY

Your Total LCD Solution Provider

Specification for TFT

AFY1280800A0-10.1INTH-C



Revision G

A	Orient Display
FY	TFT Type
1280800	Resolution 1280 x 800
A0	Serial A0
10.1	10.1", Module Dimension 232.90 x 154.60 x 6.55mm
I	IPS Display
N	Top: -20~+70°C; Tstr: -30~+80°C
T	Transmissive
H	High Brightness, 900 cd/m2
C	Capacitive Touch Panel
/	Controller HX8695-A + HX8288-A Or Compatible
/	CTP Controller GT 9271
/	LVDS Interface



CONTENTS

1. GENERAL INFORMATION	3
2. ABSOLUTE MAXIMUM RATINGS.....	3
3. ELECTRICAL CHARACTERISTICS.....	4
4. BACKLIGHT CHARACTERISTICS	5
5. TOUCH PANEL CHARACTERISTICS.....	5
6. EXTERNAL DIMENSIONS	6
7. ELECTRO-OPTICAL CHARACTERISTICS.....	6
8. INTERFACE DESCRIPTION.....	9
9. AC CHARACTERISTICS	11
10. POWER SEQUENCE.....	15
11. RELIABILITY TEST CONDITIONS	18
12. INSPECTION CRITERION.....	19
13. HANDLING PRECAUTIONS	33
14. PRECAUTION FOR USE.....	34
15. PACKING SPECIFICATION.....	34

1. GENERAL INFORMATION

No.	Item	Contents	Unit
1	LCD size	10.1 inch (Diagonal)	/
2	Display mode	IPS/Normally black/Transmissive	/
3	Viewing direction(eye)	Free	/
4	Gray scale inversion direction	-	/
5	Resolution(H*V)	1280*800 Pixels	/
6	Module size (L*W*H)	232.90*154.60*6.55	mm
7	Active area (L*W)	216.96*135.60	mm
8	Pixel pitch (L*W)	0.1695* 0.1695	mm
9	Interface type	LVDS interface	/
10	Color Depth	16.7M	/
11	Module power consumption	TBD	W
12	Back light type	LED	/
13	Driver IC	HX8288-A/HX8695-B OR COMPATIBLE(TFT)	/
14	Weight	TBD	g

2. ABSOLUTE MAXIMUM RATINGS

Item	Symbol	Min.	Max.	Unit	Note
Power supply input voltage for TFT	VDD	-0.3	+3.9	V	
Power supply input voltage for CTP	VDD	-0.3	3.6	V	
Backlight current (normal temp.)	ILED	-	225	mA	
Operation temperature	Top	-20	+70	°C	Note1
Storage temperature	Tst	-30	+80	°C	Note1
Humidity	RH	20%	90%	/	Note1

Note1 :

- 1).The relative humidity and temperature range are as below sketch,90%RH Max.
- 2).The maximum wet bulb temperature $\cong 40^{\circ}\text{C}$ and without dewing.

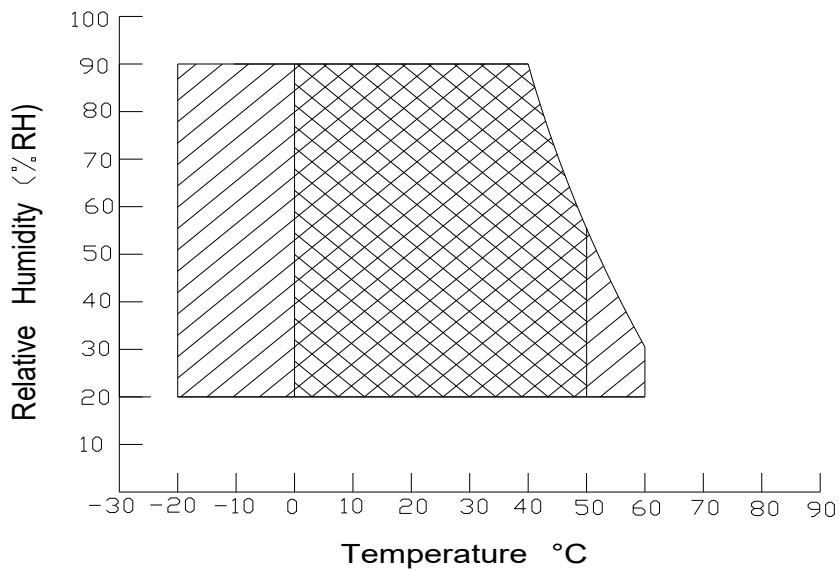

Operating Range



Storage Range

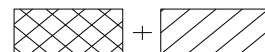

3. ELECTRICAL CHARACTERISTICS

TFT DC CHARACTERISTICS(at Ta=25°C)

Item	Symbol	Min.	Typ.	Max.	Unit	Note
Power supply input voltage	VDD	2.3	2.5	2.7	V	
I/O logic voltage	VDDIO	-	-	-	V	
Input voltage 'H' level	VIH	0.7VDDIO	-	VDDIO	V	
Input voltage 'L' level	VIL	VSS	-	0.3VDDIO	V	
Power supply current	IVDD	-	-	-	mA	
TFT gate on voltage	VGH	21.7	-	22.3	V	
TFT gate off voltage	VGL	-7.3	-	-6.7	V	
Analog power supply voltage	AVDD	8.0	8.2	8.4	V	
Differential input common mode voltage	Vcom	2.7	-	3.3	V	Note1

Note1 : The value is just the reference value. The customer can optimize the setting value by the different D-IC
Vcom must be adjusted to optimize display quality, as Crosstalk and Contrast Ratio etc..

CTP DC CHARACTERISTICS(at Ta=25°C)

Item	Symbol	Min.	Typ.	Max.	Unit	Note
Power supply input voltage	VDD	2.6	3.3	3.6	V	Note2
Input Power ripple	Vpp	-	-	50	mV	
I/O Signal Voltage	VDDIO	1.7	1.8	1.9	V	Note2
Input voltage 'H' level	VIH	0.7VDDIO	-	VDDIO	V	
Input voltage 'L' level	VIL	VSS	-	0.3VDDIO	V	
Operating Current (Normal Mode)	IVDD	-	-	-	mA	
Operating Current (Sleep mode)	IVDD	-	-	-	mA	

Note2 : If you need more information of CTP, please refer to our Spec of CTP.

4. BACKLIGHT CHARACTERISTICS

(at Ta=25°C,RH=60%)

Item	Symbol	Min.	Typ.	Max.	Unit	Note
LED forward voltage	VF	19.6	21.7	23.8	V	
LED forward current	IF	-	180	-	mA	
LED power consumption	PLED	-	3.906	-	W	Note1
Number of LED	-		42		PCS	
Connection mode	-	7 in series 6 in parallel			/	
LED life-time	-	20000	30000	-	Hrs	Note2

Note1 : Calculator value for reference : $IF \cdot VF = PLED$

Note2 : The LED life-time define as the estimated time to 50% degradation of initial brightness at Ta=25°C and IF =180mA. The LED lifetime could be decreased if operating IF is larger than 180mA.

5. TOUCH PANEL CHARACTERISTICS

(at Ta=25°C)

Item	Description	Remark
Product Structure	G+G	
Surface Hardness	6H	Pencil, Loading 500g, 45 deg
Ball-falling Test	60cm	Steel ball weight 64g
Touch Count Max	10 points	
I2C Slave Address*	0xBB&0xBA	
Origin of Coordinate*	top left corner	

7. ELECTRO-OPTICAL CHARACTERISTICS

Item	Symbol	Condition	Min.	Typ.	Max.	Unit	Remark	Note
Response time	Tr+ Tf	-	-	25	50	ms	FIG.1	Note 1
Contrast ratio	Cr		600	800	-	-	FIG.2	Note 2
Surface luminance	Lv	$\theta=0^\circ$	600	900	-	cd/m ²	FIG.2	Note 3
Luminance uniformity	Yu	$\theta=0^\circ$	75	80	-	%	FIG.2	Note 4
NTSC	-	$\theta=0^\circ$	-	50	-	%	FIG.2	Note 5
Viewing angle	θ	$\varnothing=90^\circ$	75	85	-	deg	FIG.3	Note 6
		$\varnothing=270^\circ$	75	85	-	deg	FIG.3	
		$\varnothing=0^\circ$	75	85	-	deg	FIG.3	
		$\varnothing=180^\circ$	75	85	-	deg	FIG.3	
CIE (x,y) chromaticity	Red x	$\theta=0^\circ$ $\varnothing=0^\circ$ Ta=25°C	Typ -0.04	TBD	Typ +0.04	-	FIG.2 CIE1931	Note 5
	Red y			TBD		-		
	Green x			TBD		-		
	Green y			TBD		-		
	Blue x			TBD		-		
	Blue y			TBD		-		
	White x			TBD		-		
	White y			TBD		-		

Note1. Definition of response time

The response time is defined as the LCD optical switching time interval between “White” state and “Black” state. Rise time (T_{ON}) is the time between photo detector output intensity changed from 90% to 10%. And fall time (T_{OFF}) is the time between photo detector output intensity changed from 10% to 90%. For additional information see FIG1.

Note2. Definition of contrast ratio

Contrast ratio(Cr) is defined mathematically by the following formula. For more information see FIG.2.

$$\text{Contrast ratio} = \frac{\text{Luminance measured when LCD on the "White" state}}{\text{Luminance measured when LCD on the "Black" state}}$$

Measured at the center area of the LCD

Note3. Definition of surface luminance

Surface luminance is the luminance with all pixels displaying white. For more information see FIG.2.

$$L_v = \text{Average Surface Luminance with all white pixels}(P_1, P_2, P_3, \dots, P_n)$$

Note4. Definition of luminance uniformity

The luminance uniformity in surface luminance is determined by measuring luminance at each test position 1 through n, and then dividing the maximum luminance of n points luminance by minimum luminance of n points luminance. For more information see FIG.2.

$$Y_u = \frac{\text{Minimum surface luminance with all white pixels } (P_1, P_2, P_3, \dots, P_n)}{\text{Maximum surface luminance with all white pixels } (P_1, P_2, P_3, \dots, P_n)}$$

Note5. Definition of color chromaticity (CIE1931)

CIE (x,y) chromaticity, The x,y value is determined by screen active area center position P5. For more information see FIG.2.

Note6. Definition of viewing angle

Viewing angle is the angle at which the contrast ratio is greater than 10. angles are determined for the horizontal or x axis and the vertical or y axis with respect to the z axis which is normal to the LCD surface. For more information see FIG.3.

For viewing angle and response time testing, the testing data is base on Autronic-Melchers's ConoScope or DMS series Instruments or compatible. For contrast ratio, Surface Luminance, Luminance uniformity and CIE, the testing data is base on TOPCON's BM-5or BM-7 photo detector or compatible.

FIG.1. The definition of response Time

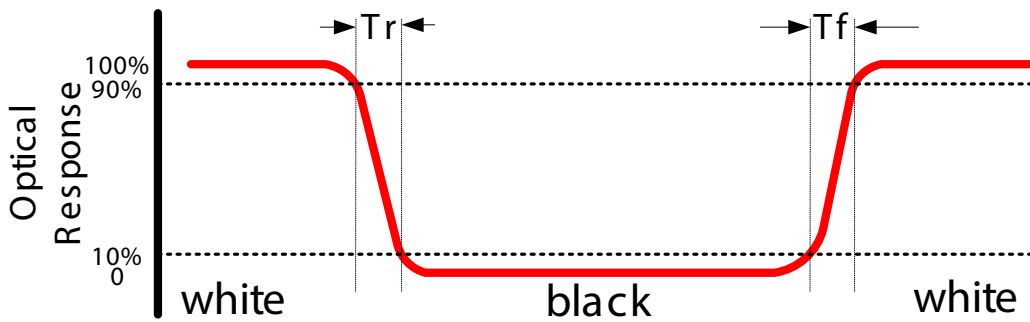

FIG.2. Measuring method for contrast ratio, surface luminance, luminance uniformity, CIE (x,y) chromaticity

H,V : Active area

Light spot size $\varnothing=1.5\text{mm}$ (BM-7)50cm distance or compatible distance from the LCM surface to detector lens.

Test spot position : see Figure a.

measurement instrument : TOPCON's luminance meter BM-7 or compatible ,see Figure b.

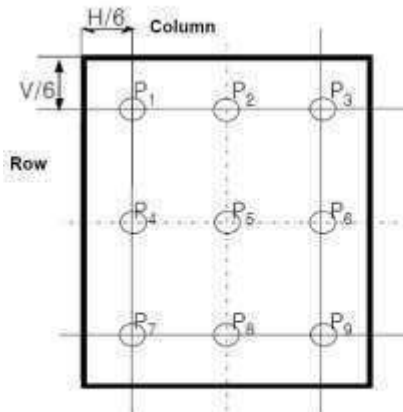

Figure a

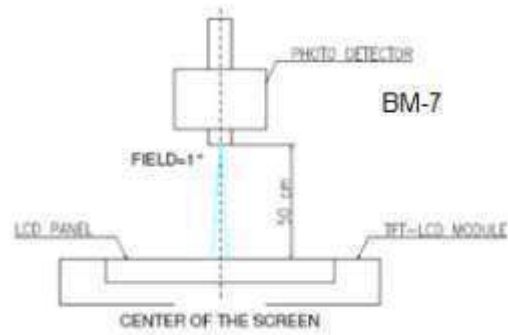
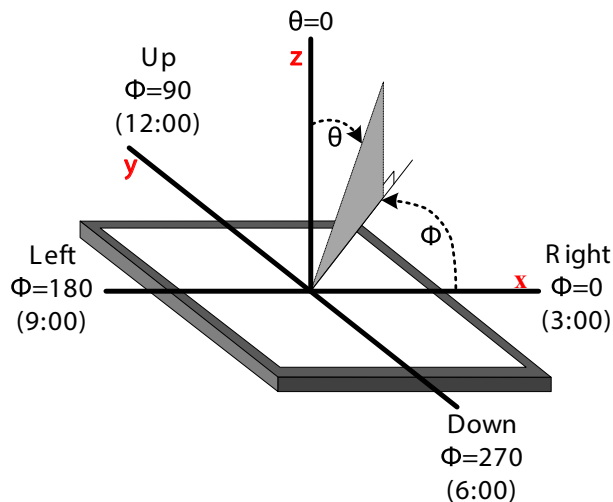

Figure b

FIG.3. The definition of viewing angle



8. INTERFACE DESCRIPTION

TFT Module Interface description

Interface NO.	NAME	I/O or connect to	DESCRIPTION
1	VCOM	P	Power Ground
2~3	VDD	P	LCD power supply
4	NC	/	No connection
5	NC	/	No connection
6	NC	/	No connection
7	GND	P	Power Ground
8	RXin0-	I	LVDS CH0 data signal(-)
9	RXin0+	I	LVDS CH0 data signal(+)
10	GND	P	Power Ground
11	RXin1-	I	LVDS CH1 data signal(-)
12	RXin1+	I	LVDS CH1 data signal(+)
13	GND	P	Power Ground
14	RXin2-	I	LVDS CH2 data signal(-)
15	RXin2+	I	LVDS CH2 data signal(+)
16	GND	P	Power Ground
17	CLKIN-	I	LVDS CLK data signal(-)
18	CLKIN+	I	LVDS CLK data signal(+)
19	GND	P	Power Ground
20	RXin3-	I	LVDS CH3 data signal(-)
21	RXin3+	I	LVDS CH3 data signal(+)
22	GND	P	Power Ground
23-24	NC	/	No connection
25	GND	P	Power Ground
26	NC	/	No connection
27	NC	/	No connection
28	NC	/	No connection

29	AVDD	P	Power for Analog circuit
30	GND	P	Power Ground
31	LEDK	P	Backlight Cathode
32	LEDK	P	
33	NC	/	No connection
34	NC	/	No connection
35	VGL	P	Gate off voltage
36	NC	/	No connection
37	NC	/	No connection
38	VGH	P	Gate on voltage
39	LEDA	P	Backlight Anode
40	LEDA	P	

CTP interface description

Interface No.	Name	I/O or connect to	Description
1	RST	I	Reset low
2	VDD	P	Power for CTP
3	GND	P	Ground
4	INT	O	State change interrupt
5	SCL	I	Serial interface clock
6	SDA	I/O	Serial interface data

9. AC CHARACTERISTICS

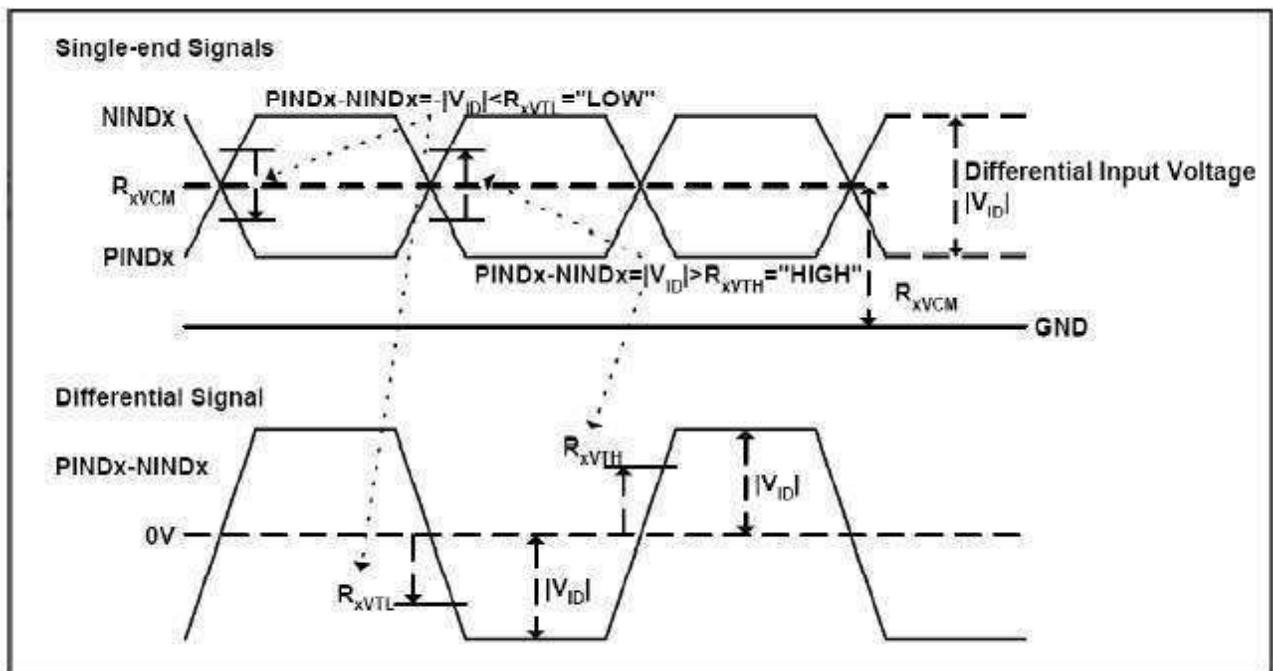

Timing table

Item	Symbol	Values			Unit	Remark
		Min.	Typ.	Max.		
Clock Frequency	$1/T_c$	68.9	71.1	73.4	MHz	Frame rate = 60Hz
Horizontal display area	t _{HD}	1280				
HS period time	t _H	1410	1440	1470	T _c	
HS Width +Back Porch +Front Porch	t _{HW} + t _{HBP} + t _{HFP}	60	160	190	T _c	
Vertical display area	t _{VD}	800				
VS period time	t _v	815	823	833	t _H	
VS Width +Back Porch +Front Porch	t _{vW} + t _{vBP} + t _{vFP}	15	23	33	t _H	

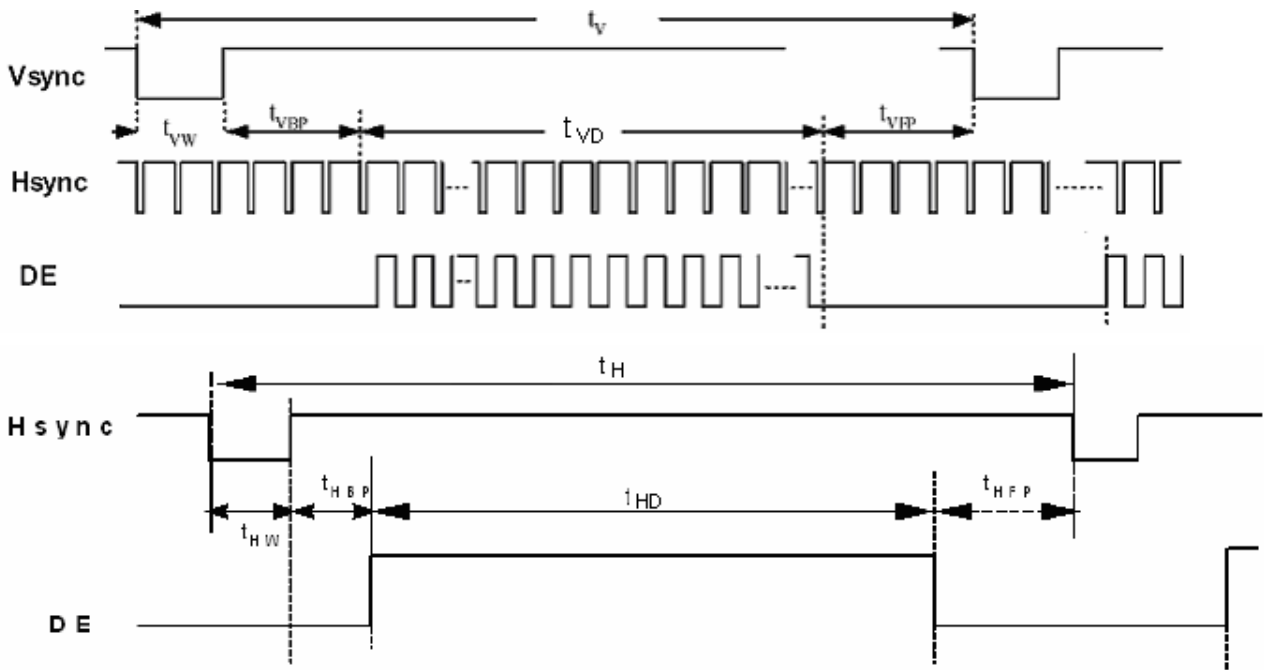

LVDS Data Input Format

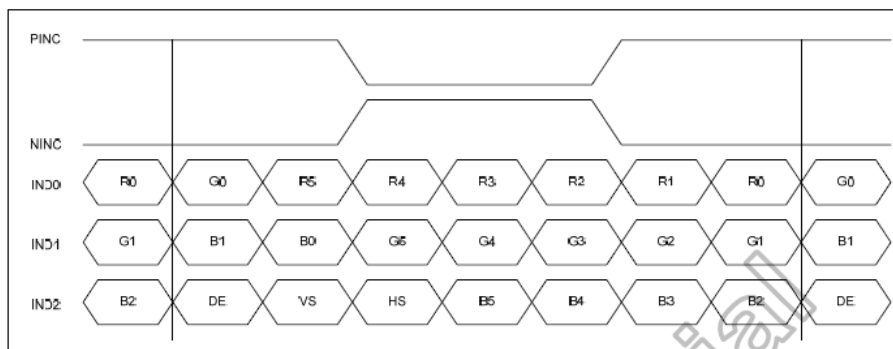
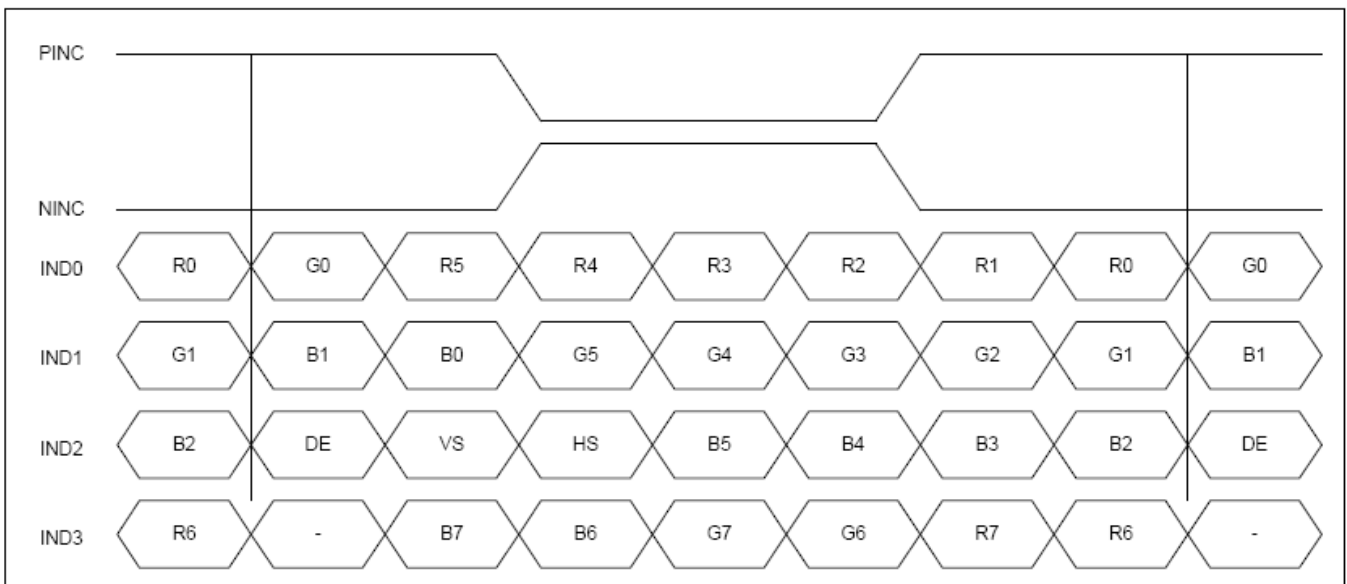

Figure 10.4: 6-bit LVDS input

CTP AC CHARACTERISTICS

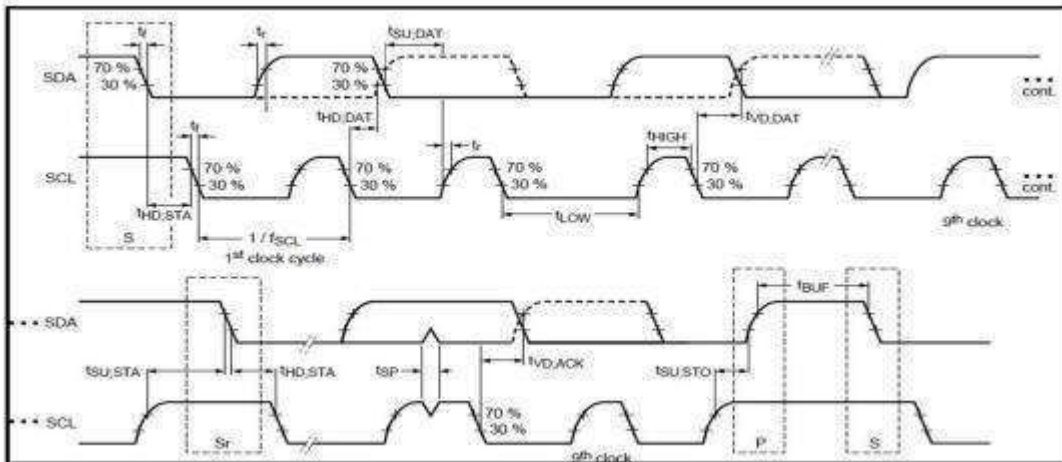

Table 5-7: I2C AC Characteristics

Parameter	Symbol	Standard-mode		Fast-mode		Unit
		Min	Max	Min	Max	
SCL clock frequency	f_{SCL}	0	100	0	400	kHz
Hold time START condition	$t_{HD,STA}$	4.0	-	0.6	-	us
LOW period of the SCL clock	t_{LOW}	4.7	-	1.3	-	us
HIGH period of the SCL clock	t_{HIGH}	4.0	-	0.6	-	us
Set-up time for a repeated START condition	$t_{SU,STA}$	4.7	-	0.6	-	us
Data hold time	$t_{HD,DAT}$	300	-	300	-	ns
Data set-up time	$t_{SU,DAT}$	250	-	100	-	ns
Rise time of both SDA and SCL signals (30% to 70%)	t_r	-	1000	20	300	ns
Fall time of both SDA and SCL signals (70% to 30%)	t_f	-	300	20	300	ns
Set-up time for STOP condition	$t_{SU,STO}$	4.0	-	0.6	-	us
Bus free time between a STOP and START condition	t_{BUF}	4.7	-	1.3	-	us
Capacitive load for each bus line	C_b	-	400	-	400	pF
Noise margin at the LOW level for each connected device	V_{NL}	$0.1V_{DD}$	-	$0.1V_{DD}$	-	V
Noise margin at the HIGH level for each connected device	V_{NH}	$0.2V_{DD}$	-	$0.2V_{DD}$	-	V

*SCL = I2C Host must to support clock stretching mode for using 400 kHz.

10. POWER SEQUENCE

Power on timing sequence

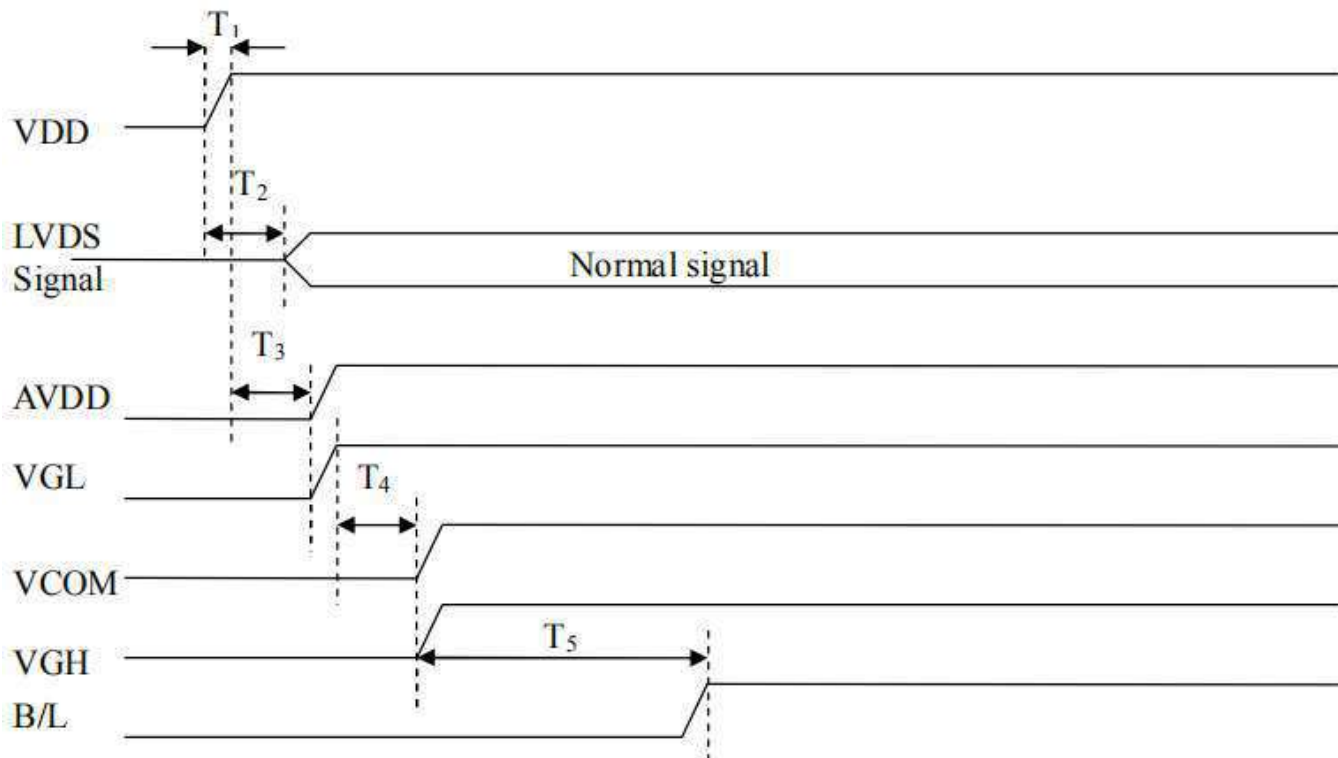

symbol	Value			Unit Min.
	Min.	Typ.	Max.	
T1	0.5	2	10	ms
T2	0	5	50	ms
T3	0	5	50	ms
T4	0	6	100	ms
T5	120	130	200	ms

Power off timing sequence

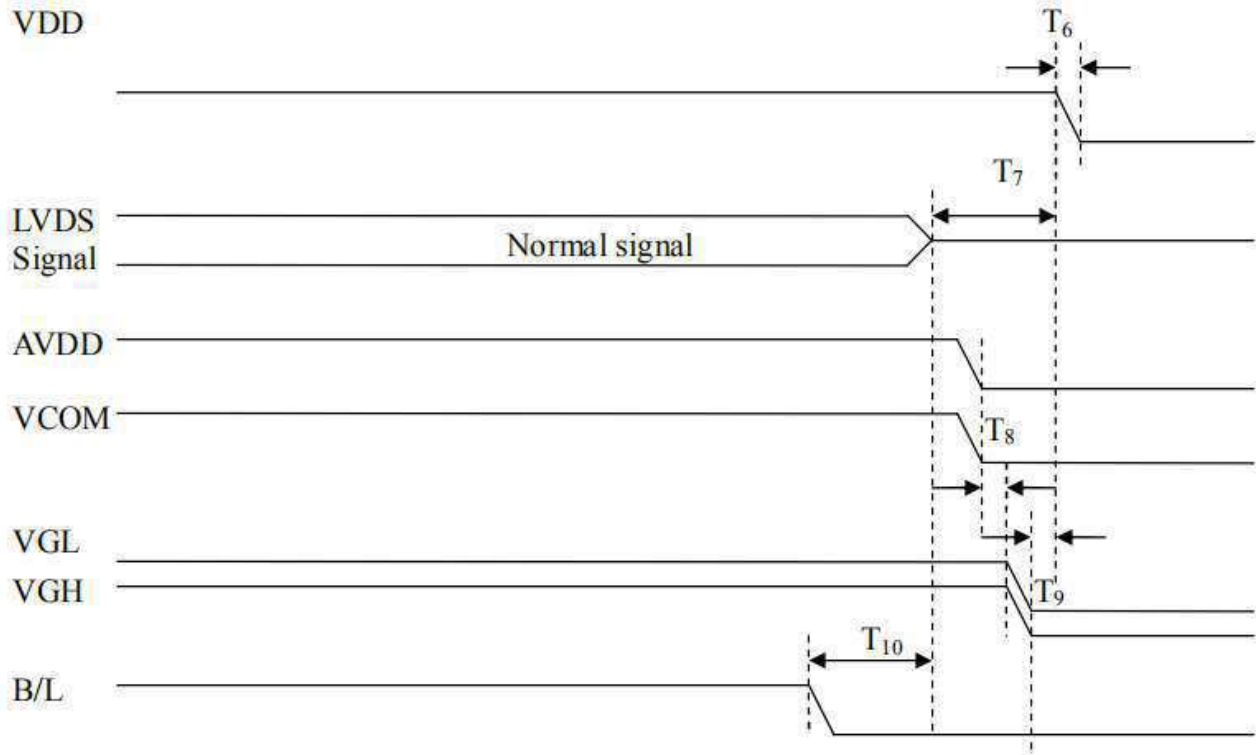

symbol	Value			Unit Min.
	Min.	Typ.	Max.	
T6	0.5	2	10	ms
T7	0	7	50	ms
T8	0	5	10	ms
T9	0	1	10	ms
T10	0	2	100	ms

CTP POWER SEQUENCE Power On

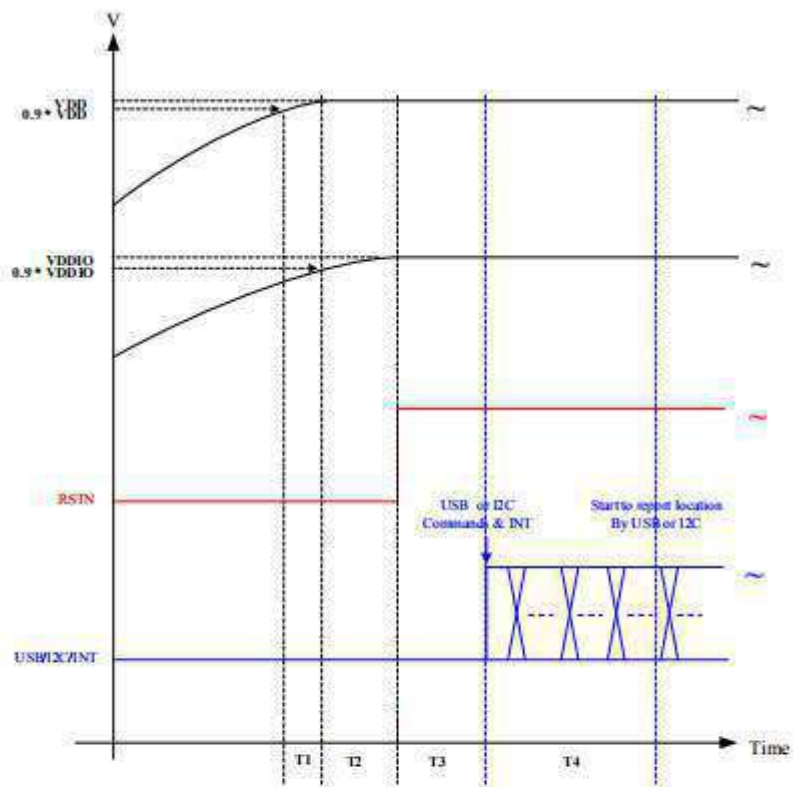

1. T1: the time difference between 0.9*VDD and 0.9*VDDIO. T1 must be ≥ 0 sec.
2. T2: the time difference between 0.9*VDDIO and RSTN. T2 must be ≥ 200 us.
3. T3: the time difference between RSTN and Commands. T3 must be ≥ 150 ms.
4. T4: IC start to report point location to host. T4 must be ≥ 300 ms.

Power Off

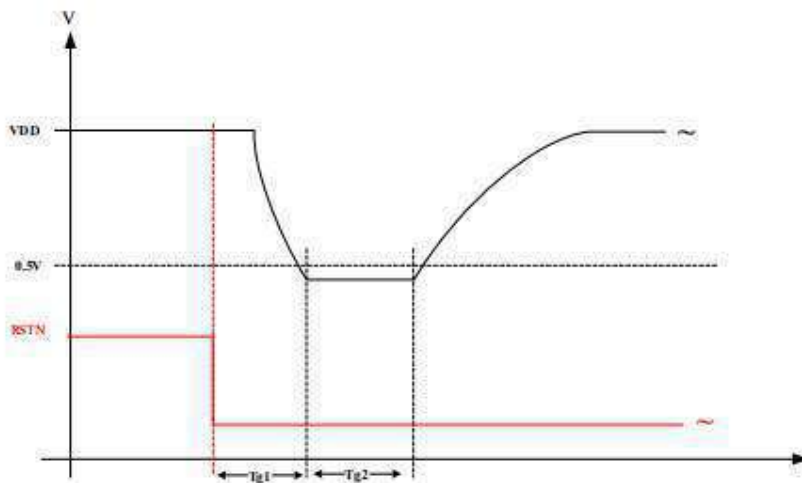

Tg1 : the time difference between power-off and power-on. Tg1 must be $> 10\mu\text{s}$.

Tg2 : the time difference between power-off and power-on. Tg2 must be $> 10\mu\text{s}$.

Note. During the power off time, the VDD must be lower than 0.5V that make sure the touch controller have been correctly reset.

11. RELIABILITY TEST CONDITIONS

No.	Test item	Test condition	Inspection after test	
11.1	High temperature storage test	+60°C/240 hours	Inspection after 2~4hours storage at room temperature, the sample shall be free from defects : 1.Current changing value before test and after test is 50% larger; 2. Function defect : Non-display,abnormal-d isplay,missing lines, Short lines,I TO corrosion; 3.Visual defect : Air bubble in the LCD,Seal leak,Glass crack.	
11.2	Low temperature storage test	-20°C/240 hours		
11.3	High temperature operating test	+50°C/120 hours		
11.4	Low temperature operating test	0°C/120 hours		
11.5	Temperature cycle storage test	-20°C ~ 25°C ~ +60°C/10cycles (30min.) (10min.) (30min.)		
11.6	High temperature high humidity test	+50°C*90% RH/120 hours		
11.7	Vibration test	Frequency : 250 r/min Amplitude : 1 inch Time: 45min		
11.8	Drop test	Drop direction: 1 corner/3 edges/6 sides 10 time		
		Packing weight(kg)		Drop height(cm)
		<11		80±1.6
		11≤G<21		60±1.2
		21≤G<31	50±1.0	
		31≤G<40	40±0.8	
11.9	ESD test	Air discharge: ±8KV, 10time Contact discharge: ±4KV, 10time		
Remark : 1.The test samples should be applied to only one test item. 2.Sample size for each test item is 3~5pcs. 3.For High temperature high humidity test, Pure water(Resistance>10MΩ) should be used. 4.In case of malfunction defect caused by ESD damage, if it would be recovered to normal state after resetting, it would be judged as a good part. 5.B/L evaluation should be excepted from reliability test with humidity and temperature: Some defects such as black spot/blemish can happen by natural chemical reaction with humidity and Fluorescence B/L has. 6.Failure judgment criterion: Basic specification, Electrical characteristic, Mechanical characteristic, Optical characteristic.				

12. INSPECTION CRITERION

12.1. Objective

The CTP test criterion are set to formalize CTP quality standards for ODNA with reference to those of the customer for inspection, release and acceptance of finished CTP products in order to guarantee the quality of CTP products required by the customer.

12.2. Scope

This specification is applicable to capacitive touch panel manufactured by ODNA.

12.3. Equipment for Inspection

lamp-box、ionizing fan、10X microscopes、film card、alcohol/oil ether/acetone、finger cots、vernier caliper、anti-static wrist straps、microcalliper、feeler、pencil hardness tester、spectrophotometer、drop ball test,etc.

12.4. Sampling Plan and Reference Standards

Sampling plan:Refer to National Standard GB/T 2828.1---2012/ISO2859-1:1999, level II of normal levels:

Product Category	Consumer	Non-consumer	Industrial	Automobile
AQL	MA=0.4 MI=1.5	MA=0.4 MI=1.0	MA=0.25 MI=0.65	MA=0.15 MI=0.40

12.5. Inspection 5.Conditions and Inspection Reference

12.5.1. Inspection environment: temperature: 23±3°C; humidity: 40~70%RH; cleanness: 10000 grade;

12.5.2 .Inspection distance: 30cm±5cm;

12.5.3. Inspection angle: vertical rotate angle: ±45°, up->down;horizontal rotate angle:±45°,left->right

12.5.4 .Inspection luminance :

(1) appearance inspection: Inspection luminance is 800~1200Lux

12.5.5 background: white/black

12.5.6. Inspection time : 10~15s/ pcs;

Black Booth or Black Background

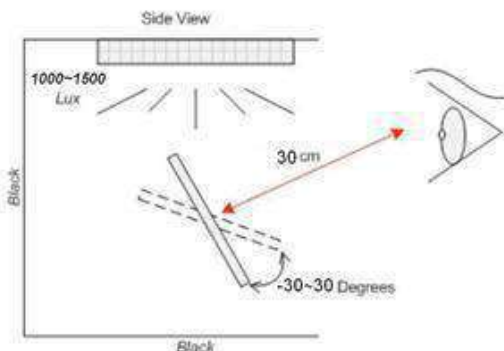

12.5.7.2 VA area: Visual Windows area (refer to below sketch Red blank);

12.5.7.3 Area A: visual area from front side view((refer to below sketch Blue blank))

12.5.7.4 Area B: four sides and FPC area((refer to below sketch Green blank))

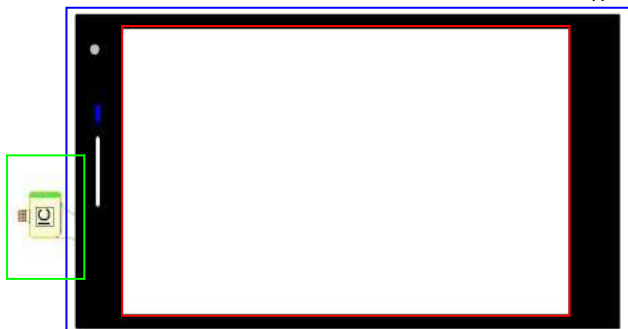

12.5.7.5 Undefined items or other special items, refer to mutual agreement and limited sample. If criterion does not match product specifications/ technical requirement, both should be subject to special inspection criterion agreed by customer.

12.5.8 Defect define:

12.5.8.1 Defect in AA area: pixel defect, function defect (no display, miss line, dark line, wrong polarizer angle, image retention, flicker, abnormal display, dim/bright display, Contrast ratio, dot defect(white dot, black dot, dark dot, Convex-concave point, bubble, foreign material), visual line defect(fiber, scratch, foreign material), stain and so on

12.5.8.2 Defect in VA area: dot defect(white dot, black dot, dark dot, Convex-concave point, bubble, foreign material), visual line defect(fiber, scratch, foreign material), stain and so on

12.5.8.3 Defect in A area: Line defect (scratch, soft flocks, fibre), dot defect (white dot, black dot, same color dot, different color dot, dust, bubble), surface stain, pin-hole, light leak, scratch.

12.5.8.4 Defect in B area: Broken, crack/chipping, FPC defect

12.5.9 Undefined items or other special items, refer to mutual agreement and limited sample. If criterion does not match product specifications/ technical requirement, both should be subject to special inspection criterion agreed by customer.

12.5.10. To the touch screen and display size of different products: The defects of TFT screen are determined according to the corresponding TFT screen size.; The defects in TP VA area are determined according to the corresponding criteria of the corresponding VA area, and the outside of the VA area is determined by the dimension standard.

12.6. Defects and Acceptance Standards

12.6.1 Function defect for TP

12.6.1 Electrical properties test

Check in ODNA tester. The program will release result automatically. There are “OK”、“PASS”、“NG” and the final judgment must be “OK”、“PASS”, and we need to pass the draw line test.

Refer to 《**serise IC test program》

No.	Defects	Descriptions	Accepted standard	MAJ	MIN
12.6.1.1	Short	Measured data has much difference compared with normal; line is not stable	Reject	√	
12.6.1.2	Open	Measured data has no change. Line is open	Reject	√	
12.6.1.3	No reaction	No reaction and there is no line in screen	Reject	√	
12.6.1.4	Mis-display/ abnormal display	Screen has display but line is open or bent	Reject	√	
12.6.1.5	Button no reaction	Press the button but no reaction	Reject	√	
12.6.1.6	Button not correct	Press the button. Reaction is not stable	Reject	√	

12.6.2 Appearance inspection

12.6.2.1 Normal lens dot/line defect

12.6.2.1.1. Industrial product point/line standard

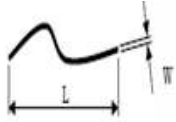
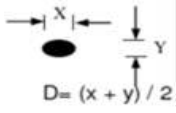
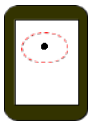
Defect	≦5”	5~10”	10~15”	>15”	Accepted standard	MAJ	MIN
S/C,line defect W:width L:length 	Tactile S/C->NG	Tactile S/C->NG	Tactile S/C->NG	Tactile S/C->NG	Reject		√
	W≦0.05mm, ->OK; Density is high ->NG	W≦0.05mm, ->OK; Density is high ->NG	W≦0.05mm, ->OK; Density is high ->NG	W≦0.08mm, ->OK; Density is high ->NG	Accept		√
	0.05mm<W ≦0.10mm, L ≦8mm quantity≦3 distance>10mm	0.05mm<W≦0.1mm, L≦10mm quantity≦6 distance>10mm	0.05mm<W≦0.1mm, L≦20mm quantity≦5 distance>10mm	0.08mm<W ≦0.1mm, L≦25mm quantity≦5 distance>10mm	Accept		√
	W>0.10mm L>8mm	W>0.1mm L>10mm	W>0.1mm L>20mm	W>0.1mm L>25mm	Reject		√
Dot defect D:Diameter  	D≦0.15mm, ->OK;	D≦0.15mm, ->OK;	D≦0.20mm, ->OK;	D≦0.30mm, ->OK;	Accept		√
	0.15mm<D≦0.25mm quantity≦3 0.25mm<D≦0.3mm quantity≦1 distance>10mm	0.15mm<D≦0.30mm quantity≦3 0.30mm<D≦0.40mm quantity≦1 distance>10mm	0.20mm<D≦0.50mm quantity≦5 distance>10mm	0.30mm<D≦0.50mm quantity≦5 distance>10mm	Accept		√
	D>0.30mm	D>0.40mm	D>0.50mm	D>0.50mm	Reject		√
Note: within 1 mm, if there are more than three (round shape), two (linear) or round shape and line shape, it is called density;							

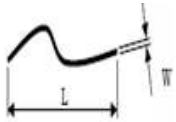

12.6.2.1.2. Non-industrial product point/line standard

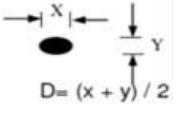
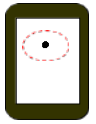
Defect	≦5”	5~10”	10~15”	>15”	Accepted standard	MAJ	MIN
S/C ,line defect W:width L:length 	Tactile S/C->NG	Tactile S/C->NG	Tactile S/C->NG	Tactile S/C->NG	Reject		√
	W≦0.03mm, ->OK; Density is high ->NG	W≦0.05mm, ->OK; Density is high ->NG	W≦0.05mm, ->OK; Density is high ->NG	W≦0.05mm, ->OK; Density is high ->NG	Accept		√
	0.03mm<W ≦0.08mm, L ≦5mm quantity≦2	0.05mm<W≦0.1mm, L≦8mm quantity≦3	0.05mm<W≦0.1mm, L≦10mm quantity≦3	0.05mm<W ≦0.1mm, L≦20mm quantity≦5	Accept		√
	W>0.08mm L>5mm	W>0.1mm L>8mm	W>0.1mm L>10mm	W>0.1mm L>20mm	Reject		√

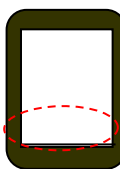
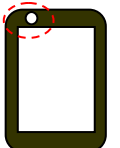
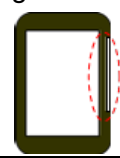

<p>Dot defect D:Diameter</p>  	$D \leq 0.10\text{mm}$, ->OK;	$D \leq 0.15\text{mm}$, ->OK;	$D \leq 0.15\text{mm}$, ->OK;	$D \leq 0.2\text{mm}$, ->OK;	Accept		✓
	$0.10\text{mm} < D \leq 0.2\text{mm}$ quantity ≤ 2 $0.2 < D \leq 0.25$, quantity ≤ 1 distance $> 10\text{mm}$	$0.15\text{mm} < D \leq 0.25\text{mm}$ quantity ≤ 3 $0.25 < D \leq 0.3$ quantity ≤ 1 distance $> 10\text{mm}$	$0.15\text{mm} < D \leq 0.30\text{mm}$ quantity ≤ 3 $0.30\text{mm} < D \leq 0.40\text{mm}$ quantity ≤ 1 distance $> 10\text{mm}$	$0.20\text{mm} < D \leq 0.50\text{mm}$ quantity ≤ 5 distance $> 10\text{mm}$	Accept		✓
	$D > 0.25\text{mm}$	$D > 0.30\text{mm}$	$D > 0.40\text{mm}$	$D > 0.50\text{mm}$	Reject		✓
Note: the scratches, lines, and points are all density and unreceiving (two or more in 1MM are called density);							

12.6.2.2. Normal lens (thickness < 1.8mm, surface without AG/AR treatment)Screen printing standard

Defect	Description	Accepted standard	MAJ	MIN
Printing zigzag 	zigzag width which is almost the same with VA area $W \leq 0.15\text{mm}$	Accept		✓
	zigzag width which is almost the same with VA area $W > 0.15\text{mm}$	Reject		✓
Wire mark 	$\leq 0.15\text{mm}$	Accept		✓
	$> 0.15\text{mm}$	Reject		✓
Ink pinhole 	Invisible with reflector light	Accept		✓
Ink film defect	Ink film:s/c、 soft flocks、 fibre Ink film stain/color shift:refer to limited sample Ink film foreign material/scratch: refer to 6.1.1 visible area judgment	Accept		✓
Ink light leak 	LENS thickness $\leq 0.7\text{mm}$: The leakage width of the edge area $\leq 0.15\text{mm}$, Unilateral light-leaking ≤ 1 LENS thickness $> 0.7\text{mm}$: The leakage width of the edge area $\leq 0.25\text{mm}$, Unilateral light-leaking ≤ 1	Accept		✓
Ink color shift	Refer to limited sample			✓
font、 glass silver line (ink area)	$D \leq 0.20\text{mm}$; $N \leq 2 \uparrow$	Accept		✓

<p>width \geq 0.2mm</p> 	<p>$D > 0.20\text{mm}$</p>	<p>Reject</p>		<p>✓</p>
	<p>Refer to limited sample, if it's out of spec</p>	<p>Reject</p>		<p>✓</p>
<p>word/color error</p>	<p>Word or color or position is different from drawing and sample.</p>	<p>Reject</p>	<p>✓</p>	
<p>word missing width \leq 0.2mm</p> 	<p>height, $a \leq 1/4h$, width $\leq 1/2w$</p>	<p>Accept</p>		<p>✓</p>
<p>Font thickness different and color nonuniform</p> 	<p>Refer to limited sample, if it's out of spec</p>	<p>Reject</p>		<p>✓</p>
<p>IR/video/ Receive hole /Button hole</p>	<p>Irregular hole , offside, refer to drawing</p>	<p>Accept</p>		<p>✓</p>
	<p>Foreign material/scratch exist in hole, refer to 6.1.1</p>	<p>Reject</p>		<p>✓</p>
<p>LENS broadside foreign material</p>	<p>Width $\leq 0.15\text{mm}$</p>	<p>Accept</p>		<p>✓</p>
<p>Ink spill</p>	<p>LENS broadside or receive hole or button hole have ink spill defect, refer to limited sample.</p>	<p>Accept</p>		<p>✓</p>

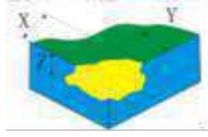
12.6.2.3 Normal lens breakdown standard

Defect	≤5”	5~10”	10~15”	>15”	Accepted standard	MAJ	MIN
LENS breakage 	X≤.3mm, Y≤.3mm, one side≤1	X≤0.3mm, Y≤0.4mm, one side≤1	X≤0.4mm, Y≤0.4mm, one side≤1	X≤0.5mm, Y≤0.5mm, one side≤1	Accept		√
	X>0.3mm, Y>0.3mm	X>0.3mm, Y>0.4mm	X>0.4mm, Y>0.4mm	X>0.5mm, Y>0.5mm	Reject		√
Sensor breakage	Not affect ITO line, not lengthen,function test is OK And be non-visual after attaching Lens				Accept		√
	affect ITO line and be visual				Reject		√
Glass crack 	Crack lengthen to outside				Accept		√
	Crack lengthen to inside				Reject		√

12.6.2.4 special lens standard

12.6.2.4.1 AG/AR processing LENS standard

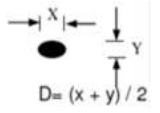
Thick ness	Defect type	S <5 inch	5≤S<10 inch	10≤S<15 inch	15 inch≤S	accept ance criterio n
thickn ess< 1.8m m	Scratch: W: width, L: length	W≤0.05, Ignore, dense except	W≤0.05, Ignore, dense except	W≤0.05, Ignore, dense except	W≤0.05, Ignore, dense except	accept
		0.05mm<W≤0.1mm, L≤12mm, N≤3	0.05mm<W≤0.1mm, L≤15mm, N≤3	0.05mm<W≤0.1mm, L≤20mm, N≤4	0.05mm<W≤0.1mm, L≤25mm, N≤5	accept
		0.1mm<W≤0.15mm, L≤12mm, N≤2	0.1mm<W≤0.15mm, L≤15mm, N≤2	0.1mm<W≤0.15mm, L≤20mm, N≤3	0.1mm<W≤0.15mm, L≤25mm, N≤4	accept
		W>0.15mm, L>12mm	W>0.15mm, L>15mm	W>0.15mm, L>20mm	W>0.15mm, L>25mm	reject
	Dot:D:diameter 	D<0.2mm,ignore, dense except	D<0.2mm,ignore, dense except	D<0.2mm,ignore, dense except	D<0.2mm,ignore, dense except	accept
		0.2mm≤D<0.3mm, N≤3	0.2mm≤D<0.3mm, N≤3, 0.3mm≤D<0.4mm, N≤1	0.2mm≤D<0.4mm, N≤3 0.4mm≤D<0.5mm, N≤1	0.2mm≤D<0.4mm, N≤3 0.4mm≤D<0.6mm, N≤2	accept
Note: point defect,the diameter is based on the etching defect , not including the ripple marks on the etching defect						
thickn ess≥ 1.8m m	Scratch: W: width, L: length	W≤0.05, Ignore, dense except	W≤0.05, Ignore, dense except	W≤0.05, Ignore, dense except	W≤0.05, Ignore, dense except	accept
		0.05mm<W≤0.1mm, L≤12mm, N≤3	0.05mm<W≤0.1mm, L≤15mm, N≤3	0.05mm<W≤0.15mm, L≤20mm, N≤4	0.05mm<W≤0.2mm, L≤25mm, N≤5	accept
		0.1mm<W≤0.15mm, L≤12mm, N≤2	0.1mm<W≤0.2mm, L≤15mm, N≤2	0.15mm<W≤0.25mm, L≤20mm, N≤2	0.2mm<W≤0.3mm, L≤25mm, N≤2	accept

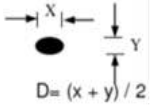
<p>Dot: D: diameter</p>  <p>$D = (x + y) / 2$</p>	<p>$D < 0.2\text{mm}$, Ignore, dense except</p>	<p>$D < 0.2\text{mm}$, Ignore, dense except</p>	<p>$D < 0.2\text{mm}$, Ignore, dense except</p>	<p>$D < 0.2\text{mm}$, Ignore, dense except</p>	accept	
	<p>$0.2\text{mm} \leq D < 0.3\text{mm}$, $N \leq 3$</p>	<p>$0.2\text{mm} \leq D < 0.3\text{mm}$, $N \leq 3$ $0.3\text{mm} \leq D < 0.4\text{mm}$, $N \leq 1$</p>	<p>$0.2\text{mm} \leq D < 0.4\text{mm}$, $N \leq 3$ $0.4\text{mm} \leq D < 0.5\text{mm}$, $N \leq 2$</p>	<p>$0.2\text{mm} \leq D < 0.4\text{mm}$, $N \leq 3$ $0.4\text{mm} \leq D < 0.6\text{mm}$, $N \leq 3$</p>	accept	
	<p>$D \geq 0.3\text{mm}$</p>	<p>$D \geq 0.4\text{mm}$</p>	<p>$D \geq 0.5\text{mm}$</p>	<p>$D \geq 0.6\text{mm}$</p>	reject	
	<p>Note: point defect, the diameter is based on the etching defect, not including the ripple marks on the etching defect</p>					
All the thickness	Edge breakage	<p>$X \leq 0.5\text{ mm}$ $Y \leq 0.5\text{ mm}$ $Z \leq 1/2 T$ One-sided only allows 1</p>	<p>$X \leq 0.5\text{ mm}$ $Y \leq 0.5\text{ mm}$ $Z \leq 1/2 T$ One-sided only allows 1</p>	<p>$X \leq 0.5\text{ mm}$ $Y \leq 0.5\text{ mm}$ $Z \leq 1/2 T$ One-sided only allows 2</p>	<p>$X \leq 0.5\text{ mm}$ $Y \leq 0.5\text{ mm}$ $Z \leq 1/2 T$ One-sided only allows 2</p>	accept
	Corner breakage	<p>$X \leq 0.5\text{ mm}$ $Y \leq 0.5\text{ mm}$ $Z \leq 1/2 T$, unilateral allowable: $N \leq 1$;</p>				
	Glass crack	<p>The crack is extended to the outer edge and is calculated according to the collapse; Progressive cracks extending to the inner edge are not allowed</p>				
	Sand edge	<p>$W \leq 0.3\text{mm}$, ignore; $W > 0.3\text{mm}$, reject</p>				
	Sawtooth	<p>The width of the sawtooth near the VA area : $W \leq 0.3\text{mm}$, allow, $W > 0.3\text{ mm}$, reject;</p>				
	Main color ink light leak	<p>Edge area leakage width : $W \leq 0.25\text{mm}$ Only unilateral leakage is allowed; Edge area leakage width $> 0.25\text{mm}$ reject</p>				
	Screen printing	<p>$W \leq 0.15\text{mm}$, allow, $W > 0.15\text{mm}$, reject</p>				
	Main color ink pinhole	<p>Outside the 2mm edge of the VA area, Reflection conditions check for invisible permission, Any pinholes are not allowed within 2mm of the area of the VA area</p>				
	Defects in the main color ink layer	<p>The ink layer has fiber, impurity reference visual area standard; Standards for scratch within the ink layer: $0.05\text{mm} < W \leq 0.08\text{mm}$, $L \leq 3\text{mm}$, $N \leq 1$, allow; $W > 0.08\text{mm}$, $L > 3\text{mm}$, reject</p>				
	Ink pattern spillage	<p>$D \leq 0.15\text{mm}$; $N \leq 2$, allow; $D > 0.15\text{mm}$, reject</p>				
	Ink pattern gap	<p>Gap width $\leq 1/4h$ (h is the height of the pattern) or gap width $\leq 1/2w$ (w is the width of the pattern) allow</p>				
	Dirty mark	<p>Printing main color stain $W \leq 0.3\text{mm}$ ignore, Not visible under fluorescent lamps, allow; Printing main color stain $W > 0.3\text{mm}$, visible under fluorescent lamps, reject</p>				
	IR semi-permeable area ink pinhole	<p>$D \leq 0.15\text{mm}$, $N \leq 1$, allow; $D > 0.15\text{mm}$, reject;</p>				
	IR semi-permeable area ink color difference	<p>Reflector is not visible in black background, acceptable</p>				
	IR semi-permeable area ink internal impurities	<p>$D \leq 0.35\text{mm}$; $N \leq 5$, allow; $D > 0.35\text{mm}$; $N > 5$, reject</p>				
	Dander foreign body	<p>$W \leq 0.3\text{mm}$, $L \leq 10\text{mm}$, $N \leq 3$, allow; $W > 0.3\text{mm}$, reject ;</p>				
	Appearance	<p>The surface is attached to a slight wipes smudge acceptable, and the air gun can be blown off of the dandruff acceptable</p>				
	AG/AR	<p>Refer to the technical signature</p>				

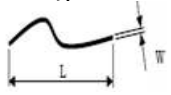
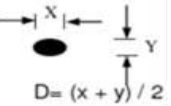
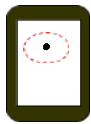

	Glass color difference	
Note: 5 or more defects within 10mm are called intensive. (intensive defects: not allowed). The spacing of all defects is 10mm		

12.6.2.4.2 Lens thickness is greater than or equal to 1.8mm product(with/without ink printing)

Defect	≦5"	5~10"	10~15"	>15"	Accepted standard
S/C , line defect W:width L:length 	W≦0.08 ignore except dense		W≦0.1 ignore except dense		accept
	0.08<W≦0.15 L≦18 mm; N≦3 0.15<W≦0.3 L≦18; N≦2	0.08<W≦0.15 L≦20mm; N≦3 0.15<W≦0.3 L≦20mm; N≦3	0.1<W≦0.2 L≦25mm; N≦4 0.2<W≦0.5 L≦25mm; N≦3	0.1<W≦0.2 L≦30mm; N≦5 0.2<W≦0.5 L≦30mm; N≦4	accept
	W>0.3, L>18	W>0.3, L>20	W>0.5mm, L>25mm	W>0.5mm, L>30mm	reject
Dot defect D:Diameter  D= (x + y) / 2 	D≦0.2mm Ignore, except dense	D≦0.2mm Ignore, except dense	D≦0.3mm Ignore, except dense	D≦0.3mm Ignore, except dense	accept
	0.2<D≦0.25, N≦2	0.2<D≦0.5, N≦5	0.3<D≦0.8, N≦5	0.3<D≦0.8, N≦6	accept
	D>0.25mm	D>0.50mm	D>0.80mm	D>0.80mm	reject
Side damage	X ≦0.5 mm Y ≦0.5 mm Z≦1/2 T Unilateral:N≦1	X ≦0.5 mm Y≦0.5 mm Z≦1/2 T Unilateral:N≦1	X ≦0.5 mm Y≦0.5 mm Z≦1/2 T Unilateral:N≦2	X ≦0.5 mm Y≦0.5 mm Z≦1/2 T Unilateral:N≦2	accept
Angle damage	X ≦0.5 mm Y≦0.5 mm Z≦1/2 T, Unilateral:N≦1				accept
Glass crack	The crack is extended to the outer edge and is calculated according to the collapse; Progressive cracks extending to the inner edge are not allowed				
Sand edge	W≦0.25mm , ignore; W>0.25mm , reject				
Sawtooth	The width of the sawtooth near the VA area : W≦0.3mm , allow, W>0.3 mm , reject;				
Main color ink light leak	Edge area leakage width : W≦0.25mm Only unilateral leakage is allowed; Edge area leakage width>0.25mm reject				
Screen printing	W≦0.15mm , allow, W>0.15mm , reject				
Main color ink pinhole	Outside the 2mm edge of the VA area, Reflection conditions check for invisible permission, Any pinholes are not allowed within 2mm of the area of the VA area				
Defects in the main color ink layer	The ink layer has fiber, impurity reference visual area standard; Standards for scratch within the ink layer: 0.05mm<W≦0.08mm, L≦3mm,N≦1, allow; W>0.08mm, L>3mm, reject				
Ink pattern spillage	D≦0.15mm; N≦2, allow; D>0.15mm , reject				
Ink pattern gap	Gap width≦1/4h (h is the height of the pattern) or gap width≦1/2w (w is the width of the pattern) allow				
Dirty mark	Printing main color stain W≦0.3mm ignore, Not visible under fluorescent lamps, allow; Printing main color stain W>0.3mm, visible under fluorescent lamps, reject				
IR semi-permeabl	D≦0.15mm, N≦1, allow; D>0.15mm, reject;				

e area ink pinhole	
IR semi-permeable area ink color difference	Reflector is not visible in black background, acceptable
IR semi-permeable area ink internal impurities	$D \leq 0.35\text{mm}$; $N \leq 5$, allow; $D > 0.35\text{mm}$; $N > 5$, reject
Note: 1. 5 or more defects within 10mm are called intensive. (intensive defects: not allowed). The spacing of all defects is 10mm 2. inspection distance: $750 \pm 50\text{mm}$, if appearance is invisible, ignore	

12.6.2.5 . FPC defect

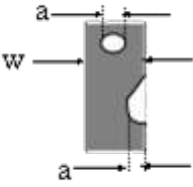
Defect	Description	Accepted standard	MAJ	MIN
FPC folding 	FPC is folding and can not restore-> Reject FPC is folding and can restore->compare with limited sample	Reject		✓
FPC cover layer defect	FPC cover layer peeling off	Reject		✓
FPC color shift and bubble	PI layer have color shift or bubbled due to high welding temperature or long welding time.	Reject		✓
Golden finger defect 	peeling off、bonding deformed、glue remained、oxidized, stained	Reject		✓
Joggle defect 	bent, broken, peeling off	Reject		✓
FPC defect 	(golden finger) dented, pin hole $a \leq w/3$	Accept		✓
	open/scratch/cracked/Gold finger has glue/FPC surface has glue accumulation	Reject		✓
	oxidized, stained	Reject		✓
FPC loophole	In the protected line area Or not affecting normal lines, The soft batch $\leq 2.5\text{ mm}$, accept , Hard board (PCB, PC, steel sheet reinforcing plate)The soft batch $\leq 1.0\text{mm}$ Or less than half of the edge of the wire to the edge (Take a smaller value)	Accept		✓

12.6.2.6. Attaching defect (protective film/adhesive tape/foam/PC...)

Defect	Description	Accepted standard	MAJ	MIN
High temperature glue paper	Glue paper attached in FPC doesn't cover component or FPC cove layer. 2.Glue paper attached in golden finger doesn't cover golden finger or peel off	Reject		√
Protective film	Clean、 attaching flat、 no shifting or bubble	Accept		√
	Protective film attaching bubble in VA: D≤2.0mm N≤5 distance≤20mm	Accept		√
	Protective film attaching bubble in VA: D>2.0mm N>5 distance>20mm	Reject		√
Tape	Attach position refer to the drawing	Accept		√
Foam	1. Follow the drawings first 2. If the drawings are not specified in size, refer to the following requirements Gap spec:0.5+/-0.5mm, foam must be smaller than sensor edge side and can not enter into VA.	Accept		√
PC board/ adhesive tape	Tape must be smaller than LENS edge side and can not be folding ,dent or shifting.Do not obstruct the hole;	Accept		√
Anti-explosion fim/Anti-glare film/blue film/AG film	Impression print refer to the limited sample	Accept		√
	Attach position refer to the drawing	Accept		√
	The bubbles are not allowed in the OCA rubber layer, and the bubbles are ignored between the lens and the AG layer or the explosion-proof film layer	Accept		√

12.6.2.7. Metal frame (Metal Bezel)

No.	Item	Description	Accepted criterion	MAJ	MIN
12.6.2.7.1	Material & surface treatment	Metal frame/surface treatment do not conform to the specifications.	Rejected	√	
12.6.2.7.2	Tab twist Unconformity/ Tab not twisted	Wrong twist method or direction and twist tabs are not twisted as required.	Rejected	√	
12.6.2.7.3	Bezel paint loss	Scratch/paint loss/Bezel surface concave-convex dot/dent	1.Front surface: Paint peel off and scratch to the bottom Dot:D≤0.5mm, exceeds 3; Line:L≤3.0mm,W≤0.05mm exceeds 2; 2.Front dent, air bubble and side with paint peeling off scratch to the bottom Dot: D≤1.0mm, exceeds 3; Line:L≤3.0mm,W≤0.05mm, exceeds 2;	√	
12.6.2.7.4	Bezel scratch			√	
12.6.2.7.5	Painting peel off, discoloration,dent, and scratch			√	
12.6.2.7.6	Burr	Burr(s) on metal bezel is so long as to get into viewing area.	Rejected	√	

12.6.2.8. Others

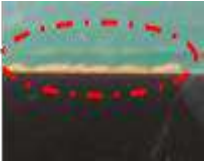
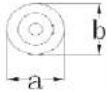
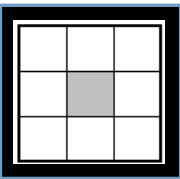
Defect	Description	Accepted standard	MAJ	MIN
Glue flow 	Insulation oil flow in VA area	Reject		✓
	ACF/insulation oil flow in VA area	Reject		✓
	Sensor edge side glue flow	Accept		✓
IC/FPC gap glue	FPC gap glue:cover FPC connect point totally IC glue: cover IC line connect totally	Accept		✓
	Glue height : follow the technology spec	Accept		✓
Newton circles (rainbow) 	Circles quantity > 2	Reject		✓
Layering	LENS/Sensor layering	Reject	✓	
Surface	Stain defect which can be removed by cleaning solvent and cloth Defect quantity ≤ 10% Lot total quantity->Accept Remark: defect product which is sorted out by AQL is not included in the 10% part.Unmovable stain refer to 6.1.1 specification.	Reject		✓
Isolation point  VA diagram	Gray area In 8X8mm area, all isolation points are missing	Reject		✓
	White area In 15X15mm area,all isolation points are missing	Reject		✓
	5mm within VA (black area) , isolation points missing ->Ignored	Accept		✓
	Isolation points are overlaid	Accept		✓

12.6.3 .Function inspection standard for TFT-LCM final goods

12.6.3.1 normal defect in TFT screen

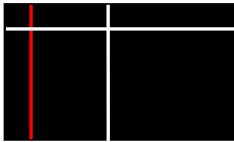
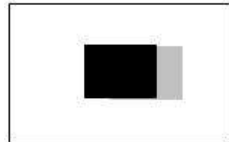
Defects	Inspection Criterion	Pictures	Inspection method/tools	Defect category
Flicker No display /reaction	Not accepted shows no picture/display in normal connected situation. ->Rejected		Naked eyes/ testers Naked eyes/ testers	MA MA
Missing segment	Shows missing lines in normal display		Naked eyes/ testers	MA
Image retention (sticking)	The previous picture stays in the next picture.Disappear time <10s, OK; time>10s, NG		Naked eyes/ testers	MA

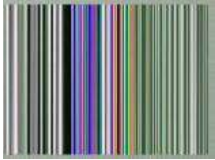
Display abnormal	Not accepted		Naked eyes/ testers	MA
Display dim/bright	Refer to limited sample	/	Naked eyes/ limited sample	MA
Contrast	Refer to limited sample	/	Naked eyes/ limited sample	MA
White dot	Refer to dot criterion	/	Naked eyes	MI
White speckle	Refer to limited sample	/	Naked eyes/ limited sample	MI
Yellow speckle	Refer to limited sample	/	Naked eyes/ limited sample	MI

12.6.3.2 LCD pixel dot defect in TFT screen (defect category: MI)

Item	Inspection criterion			
	S < 5"	5 ≤ S < 10"	10 ≤ S < 15"	> 15"
Color pixel dot defect(RGB dot)	1	2	2	3
2 connected bright dot	0	0	1	1
3 connected bright dot or more	0	0	0	0
Bright dot quantity	1	2	3	4
Random dark dot quantity	2	3	4	5
2 connected dark dot	1	1	2	2
3 connected dark dot or more	0	0	0	0
Dark dot quantity	3	4	5	6
Multi-bright dot	ND 5% hidden, OK			
Remark: 2 bright dots distance DS ≥ 15mm 2 dark dots distance DS ≥ 5mm				
1) Bright dot: Power on TFT and RGB dot in black display				
2) Dark dot: Power on TFT and gray or black dot in RGB display				
3) Multi-bright dot: Power on TFT and fluorescent tiny dot in black display(only visible in black display)				

12.6.3.3 Metal frame (Metal Bezel)

Item	Description	Accepted criterion	MAJ	MIN
Material & surface treatment	Metal frame/surface treatment do not conform to the specifications.	Rejected	√	
Tab twist Unconformity/ Tab not twisted	Wrong twist method or direction and twist tabs are not twisted as required.	Rejected	√	
Bezel paint loss	Scratch/paint loss/Bezel surface concave-convex dot/dent	1.Front surface: Paint peel off and scratch to the bottom Dot:D ≤ 0.5mm, exceeds 3;	√	
Bezel scratch			√	

Painting peel off, discoloration, dent, and scratch		Line: $L \leq 3.0\text{mm}$, $W \leq 0.05\text{mm}$ exceeds 2; 2. Front dent, air bubble and side with paint peeling off scratch to the bottom Dot: $D \leq 1.0\text{mm}$, exceeds 3; Line: $L \leq 3.0\text{mm}$, $W \leq 0.05\text{mm}$, exceeds 2;	√	
Burr	Burr(s) on metal bezel is so long as to get into viewing area.	Rejected	√	

12.6.3.3 Backlight components

Item	Description	Accepted criterion	MAJ	MIN
No backlight wrong Color	/	Rejected	√	
Color deviation	When powered on, the LCD color differs from its sample and found that the color not conforming to the drawing after testing.	Refer to sample and drawing.		√
Brightness deviation	When powered on, the LCD brightness differs from its sample and is found after testing not conforming to the drawing; or if it conforms to the drawing but the brightness over $\pm 40\%$ than its typical value.	Refer to sample and drawing.		√
Uneven brightness	Uneven on the same LCD and out of the specification of the drawing. The no specification evenness = $(\text{the max value} - \text{the min value}) / \text{mean value} < 70\%$.	Refer to sample and drawing.		√
Spot/line /scratch	When power on, it has dirty spot, scratches and so on spot and line defects.	Refer to dot/line standard		√

12.6.3.4. Others

Item	Description	Accepted criterion	MAJ	MIN
Assembly foreign material	Dot/linear stain after assembly backlight and diffuse film TP assembly foggy stain	Invisible when power on -> OK Refer to 6.1.1 dot/line spec		√
Product mark	Missing, unclear, incorrect, or misplaced part	Rejected		√
Newton' s rings	Area < 1/6 screen area quantity ≤ 1	Accepted		√
Mura	In black display ND 5% invisible -> OK; visible -> NG 2. Naked eyes inspection RGB display invisible Black display, area < 1/4 screen area	Refer to limited sample 		√

Light leak	LCD edge (near backlight) shadow by LCD lamps irregular illuminate Judge in black/white/gray display (slight leaky is yellowish, greenish, blueish ->NG) ; 	Refer to limited sample		√
Polarizer	Polarizer slant. Cover VA and not over LCD edge 2.No unmovable stain or finger print in polarizer VA 3.Bubble/warped but not enter VA	Accepted		√

12.6.4. General Appearance and Dimension (Major)

Common inspection equipment : micro calliper、 vernier caliper、 pencil hardness tester、 spectrophotometer、 drop ball test and etc.

Items	Spec
Dimension	According to drawing
Curl	≤0.3% -> OK, " S" curl ->NG
Surface hardness	According to drawing
VA TT (550nm)	According to drawing
IR TT-- (550nm & 850nm)	According to drawing
Intensity (drop ball test)	According to drawing

Remark: the criterion is common for all product and if some components are not included, just ignore it.

12.7. Others

Items not specified in this document or released on compromise should be inspected with reference to mutual agreement and limit samples.

13. HANDLING PRECAUTIONS

13.1 Mounting method

The LCD module consists of two thin glass plates with polarizers which easily be damaged. And since the module is so constructed as to be fixed by utilizing fitting holes in the printed circuit board.

Extreme care should be needed when handling the LCD modules.

13.2 Caution of LCD handling and cleaning

When cleaning the display surface, Use soft cloth with solvent [recommended below] and wipe lightly :

- .Isopropyl alcohol
- .Ethyl alcohol

Do not wipe the display surface with dry or hard materials that will damage the polarizer surface.

Do not use the following solvent :

- .Water
- .Aromatics

Do not wipe ITO pad area with the dry or hard materials that will damage the ITO patterns

Do not use the following solvent on the pad or prevent it from being contaminated :

- .Soldering flux
- .Chlorine (Cl) , Sulfur (S)

If goods were sent without being silicon coated on the pad, ITO patterns could be damaged due to the corrosion as time goes on.

If ITO corrosion happens by miss-handling or using some materials such as Chlorine (Cl), Sulfur (S) from customer, Responsibility is on customer.

13.3 Caution against static charge

The LCD module uses C-MOS LSI drivers, so we recommend that you :

Connect any unused input terminal to Vdd or Vss, do not input any signals before power is turned on, and ground your body, work/assembly areas, assembly equipment to protect against static electricity.

13.4 Packing

Module employs LCD elements and must be treated as such.

- .Avoid intense shock and falls from a height.
- .To prevent modules from degradation, do not operate or store them exposed direct to sunshine or high temperature/humidity.

13.5 Caution for operation

- .It is an indispensable condition to drive LCD's within the specified voltage limit since the higher voltage than the limit causes the shorter LCD life.
- .An electrochemical reaction due to direct current causes LCD's undesirable deterioration, so that the use of direct current drive should be avoided.
- .Response time will be extremely delayed at lower temperature than the operating temperature range and on the other hand at higher temperature LCD's show dark color in them. However those phenomena do not mean malfunction or out of order with LCD's, which will come back in the specified operation temperature.
- .If the display area is pushed hard during operation, some font will be abnormally displayed but it resumes normal condition after turning off once.
- .A slight dew depositing on terminals is a cause for electro-chemical reaction resulting in terminal open circuit.
- .Usage under the maximum operating temperature, 50%Rh or less is required.
- .When fixed patterns are displayed for a long time, remnant image is likely to occur.

13.6 Storage

In the case of storing for a long period of time for instance, for years for the purpose of replacement use, the following ways are recommended.

- .Storing in an ambient temperature 10°C to 30°C, and in a relative humidity of 45% to 75%. Don't expose to sunlight or fluorescent light.
- .Storing in a polyethylene bag with the opening sealed so as not to enter fresh air outside in it . And with no desiccant.
- .Placing in a dark place where neither exposure to direct sunlight nor light's keeping the storage temperature range.
- .Storing with no touch on polarizer surface by anything else.

It is recommended to store them as they have been contained in the inner container at the time of delivery from us.

13.7 Safety

- .It is recommendable to crash damaged or unnecessary LCD's into pieces and wash off liquid crystal by _____

either of solvents such as acetone and ethanol, which should be burned up later.

- .When any liquid leaked out of a damaged glass cell comes in contact with your hands, please wash it off well with soap and water.

14. PRECAUTION FOR USE

14.1 A limit sample should be provided by the both parties on an occasion when the both parties agreed its necessity. Judgment by a limit sample shall take effect after the limit sample has been established and confirmed by the both parties.

14.2 On the following occasions, the handing of problem should be decided through discussion and agreement between responsible of the both parties.

- .When a question is arisen in this specification.
- .When a new problem is arisen which is not specified in this specifications.
- .When an inspection specifications change or operating condition change in customer is reported to ODNA, and some problem is arisen in this specification due to the change.
- .When a new problem is arisen at the customer's operating set for sample evaluation in the customer site.

15. PACKING SPECIFICATION

Please consult our technical department for detail information.