

NOTES :

HOLE SIZE : 6.85/6.85

THICKNESS RANGE : 1.6/3.2

SCREW SIZE : 6

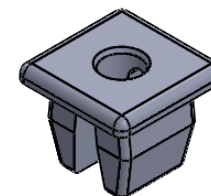
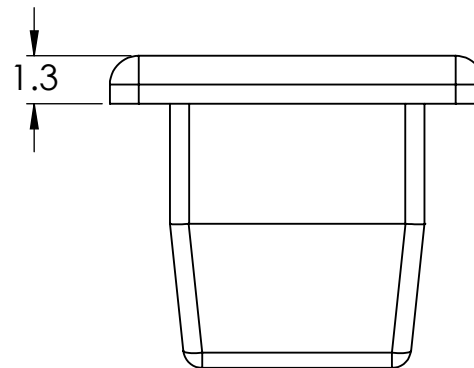
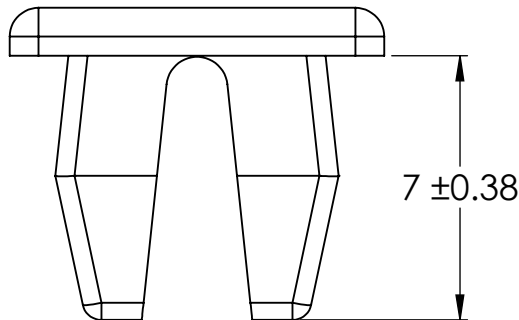

2:1

UNLESS OTHERWISE STATED

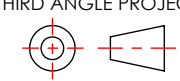
ALL DIMENSIONS IN mm	DO NOT SCALE
LINEAR TOLERANCE	THIRD ANGLE PROJECTION
SIZE (0) (0.0) (0.00)	
0-10mm ±0.5 ±0.15 ±0.10	ANGULAR TOLERANCE ±0.5 DEGREES
>10-30 ±0.5 ±0.20 ±0.15	UNSPECIFIED RADII 0.25mm
>30-50 ±0.5 ±0.30 ±0.20	DRAFT ANGLE 0.5 DEGREES
>50-100 ±0.8 ±0.50 ±0.25	DIMENSIONS IN BRACKETS [ ] ARE IN INCHES FOR REFERENCE ONLY
>100-200 ±1.5 ±0.80 ±0.40	
>200-300 ±2.0 ±1.20 ±0.80	
>300-500 ±3.0 ±2.00 ±1.00	
>500 ±5.0 ±3.00 ±1.50	

ORG. SCALE: 5:1 CREATE DATE: 10/12/2018

MATERIAL: PA 66

Part ID: 1456115 Project: P160230-1

TITLE: GROMMET NUT 1.58-3.17 H 1.27

DWG. No. 60SGN01165 SHEET 1 of 1 ISSUE 1

APPROVED - UNCONTROLLED