

86 mm sq. (3.39 inch sq.)

1.8° /step RoHS

Bipolar winding, Lead wire type
 Bipolar winding, Lead wire type CE/UL model
 Bipolar winding, Terminal block type CE/UL model
 Unipolar winding, Lead wire type ▶ p. 78
 Unipolar winding, Lead wire type CE/UL model ▶ p. 78

Customizing

Hollow Shaft modification
Encoder

Varies depending on the model number and quantity. Contact us for details.

Bipolar winding, Lead wire type

Model number		Holding torque at 2-phase energization [N·m (oz·in) min.]	Rated current A/phase	Wiring resistance Ω /phase	Winding inductance mH/phase	Rotor inertia [×10 ⁻⁴ kg·m ² (oz·in ²)]	Mass (Weight) [kg (lbs)]	Motor length (L) mm (in)
Single shaft	Dual shaft							
SH2861-5041	SH2861-5011	3.3 (467.3)	2	2.2	15	1.48 (8.09)	1.75 (3.92)	66 (2.6)
SH2861-5141	SH2861-5111	3.3 (467.3)	4	0.56	3.7	1.48 (8.09)	1.75 (3.92)	66 (2.6)
SH2861-5241	SH2861-5211	3.3 (467.3)	6	0.29	1.7	1.48 (8.09)	1.75 (3.92)	66 (2.6)
SH2862-5041	SH2862-5011	6.4 (906.3)	2	3.2	25	3.0 (16.4)	2.9 (6.5)	96.5 (3.8)
SH2862-5141	SH2862-5111	6.4 (906.3)	4	0.83	6.4	3.0 (16.4)	2.9 (6.5)	96.5 (3.8)
SH2862-5241	SH2862-5211	6.4 (906.3)	6	0.36	2.8	3.0 (16.4)	2.9 (6.5)	96.5 (3.8)
SH2863-5041	SH2863-5011	9 (1274.4)	2	4.0	32	4.5 (24.6)	4.0 (8.96)	127 (5)
SH2863-5141	SH2863-5111	9 (1274.4)	4	1.0	7.9	4.5 (24.6)	4.0 (8.96)	127 (5)
SH2863-5241	SH2863-5211	9 (1274.4)	6	0.46	3.8	4.5 (24.6)	4.0 (8.96)	127 (5)

Bipolar winding, Lead wire type CE/UL model

Model number		Holding torque at 2-phase energization [N·m (oz·in) min.]	Rated current A/phase	Wiring resistance Ω /phase	Winding inductance mH/phase	Rotor inertia [×10 ⁻⁴ kg·m ² (oz·in ²)]	Mass (Weight) [kg (lbs)]	Motor length (L) mm (in)
Single shaft	Dual shaft							
SM2861-5051	SM2861-5021	3.3 (467.3)	2	2.2	15	1.48 (8.09)	1.75 (3.92)	66 (2.6)
SM2861-5151	SM2861-5121	3.3 (467.3)	4	0.56	3.7	1.48 (8.09)	1.75 (3.92)	66 (2.6)
SM2861-5251	SM2861-5221	3.3 (467.3)	6	0.29	1.7	1.48 (8.09)	1.75 (3.92)	66 (2.6)
SM2862-5051	SM2862-5021	6.4 (906.3)	2	3.2	25	3.0 (16.4)	2.9 (6.5)	96.5 (3.8)
SM2862-5151	SM2862-5121	6.4 (906.3)	4	0.83	6.4	3.0 (16.4)	2.9 (6.5)	96.5 (3.8)
SM2862-5251	SM2862-5221	6.4 (906.3)	6	0.36	2.8	3.0 (16.4)	2.9 (6.5)	96.5 (3.8)
SM2863-5051	SM2863-5021	9 (1274.4)	2	4.0	32	4.5 (24.6)	4.0 (8.96)	127 (5)
SM2863-5151	SM2863-5121	9 (1274.4)	4	1.0	7.9	4.5 (24.6)	4.0 (8.96)	127 (5)
SM2863-5251	SM2863-5221	9 (1274.4)	6	0.46	3.8	4.5 (24.6)	4.0 (8.96)	127 (5)

Bipolar winding, Terminal block type CE/UL model

Model number		Holding torque at 2-phase energization [N·m (oz·in) min.]	Rated current A/phase	Wiring resistance Ω /phase	Winding inductance mH/phase	Rotor inertia [×10 ⁻⁴ kg·m ² (oz·in ²)]	Mass (Weight) [kg (lbs)]	Motor length (L) mm (in)
Single shaft	Dual shaft							
SM2861-5066		3.3 (467.3)	2	2.03	15	1.48 (8.09)	1.9 (4.19)	97.9 (3.9)
SM2861-5166		3.3 (467.3)	4	0.52	3.7	1.48 (8.09)	1.9 (4.19)	97.9 (3.9)
SM2861-5266		3.3 (467.3)	6	0.27	1.7	1.48 (8.09)	1.9 (4.19)	97.9 (3.9)
SM2862-5066		6.4 (906.3)	2	3.08	25	3.0 (16.4)	3.05 (6.72)	128.4 (5.1)
SM2862-5166		6.4 (906.3)	4	0.79	6.4	3.0 (16.4)	3.05 (6.72)	128.4 (5.1)
SM2862-5266		6.4 (906.3)	6	0.33	2.8	3.0 (16.4)	3.05 (6.72)	128.4 (5.1)
SM2863-5066		9 (1274.4)	2	3.83	32	4.5 (24.6)	4.15 (9.15)	158.8 (6.3)
SM2863-5166		9 (1274.4)	4	0.96	7.9	4.5 (24.6)	4.15 (9.15)	158.8 (6.3)
SM2863-5266		9 (1274.4)	6	0.48	3.8	4.5 (24.6)	4.15 (9.15)	158.8 (6.3)

Characteristics diagram

SH2861-5041
SH2861-5011

SM2861-5051
SM2861-5021

SM2861-5066

Constant current circuit
 Source voltage: 100 VAC
 Operating current:
 2 A/phase, 2-phase
 energization (full-step)
 $J_L = [15.3 \times 10^{-4} \text{kg} \cdot \text{m}^2 (83.65 \text{oz} \cdot \text{in}^2)]$ use the rubber
 coupling]
 f_s : Maximum self-start
 frequency when not
 loaded

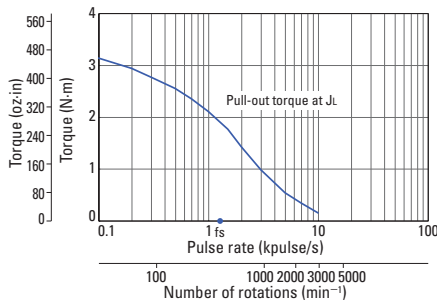

SH2861-5141
SH2861-5111

SM2861-5151
SM2861-5121

SM2861-5166

Constant current circuit
 Source voltage: 100 VAC
 Operating current:
 4 A/phase, 2-phase
 energization (full-step)
 $J_L = [15.3 \times 10^{-4} \text{kg} \cdot \text{m}^2 (83.65 \text{oz} \cdot \text{in}^2)]$ use the rubber
 coupling]
 f_s : Maximum self-start
 frequency when not
 loaded

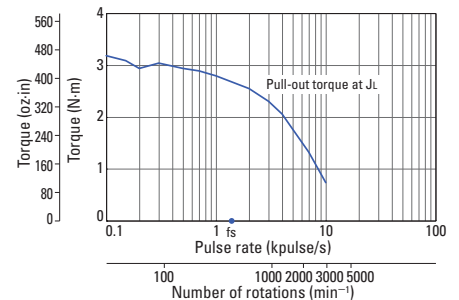

Characteristics diagram

SH2861-5241
SH2861-5211

SM2861-5251
SM2861-5221

SM2861-5266

Constant current circuit
Source voltage: 100 VAC
Operating current:
6 A/phase, 2-phase
energization (full-step)
 $J_L = [15.3 \times 10^{-4} \text{kg} \cdot \text{m}^2 (83.65 \text{oz} \cdot \text{in}^2)]$ use the rubber
coupling)
 f_s : Maximum self-start
frequency when not
loaded

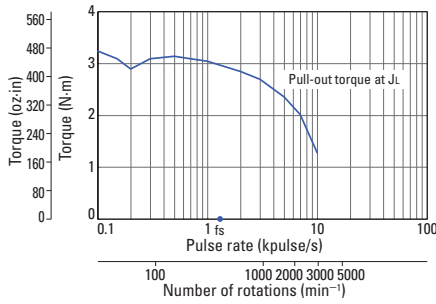

SH2862-5041
SH2862-5011

SM2862-5051
SM2862-5021

SM2862-5066

Constant current circuit
Source voltage: 100 VAC
Operating current:
2 A/phase, 2-phase
energization (full-step)
 $J_L = [15.3 \times 10^{-4} \text{kg} \cdot \text{m}^2 (83.65 \text{oz} \cdot \text{in}^2)]$ use the rubber
coupling)
 f_s : Maximum self-start
frequency when not
loaded

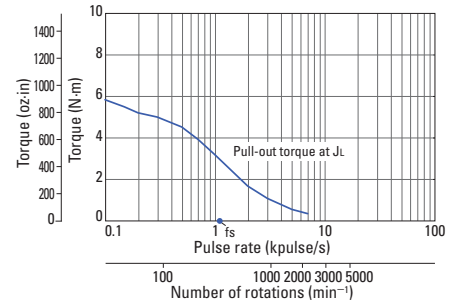

SH2862-5141
SH2862-5111

SM2862-5151
SM2862-5121

SM2862-5166

Constant current circuit
Source voltage: 100 VAC
Operating current:
4 A/phase, 2-phase
energization (full-step)
 $J_L = [15.3 \times 10^{-4} \text{kg} \cdot \text{m}^2 (83.65 \text{oz} \cdot \text{in}^2)]$ use the rubber
coupling)
 f_s : Maximum self-start
frequency when not
loaded

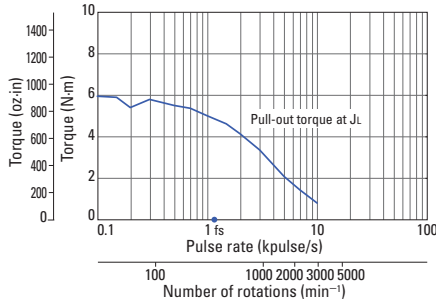

SH2862-5241
SH2862-5211

SM2862-5251
SM2862-5221

SM2862-5266

Constant current circuit
Source voltage: 100 VAC
Operating current:
6 A/phase, 2-phase
energization (full-step)
 $J_L = [15.3 \times 10^{-4} \text{kg} \cdot \text{m}^2 (83.65 \text{oz} \cdot \text{in}^2)]$ use the rubber
coupling)
 f_s : Maximum self-start
frequency when not
loaded

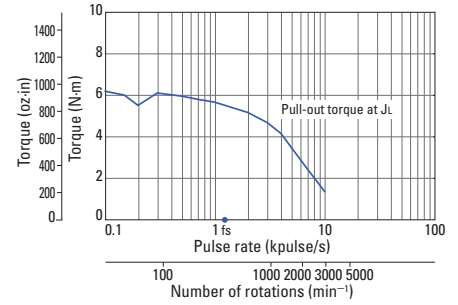

SH2863-5041
SH2863-5011

SM2863-5051
SM2863-5021

SM2863-5066

Constant current circuit
Source voltage: 100 VAC
Operating current:
2 A/phase, 2-phase
energization (full-step)
 $J_L = [44 \times 10^{-4} \text{kg} \cdot \text{m}^2 (240.56 \text{oz} \cdot \text{in}^2)]$ use the rubber
coupling)
 f_s : Maximum self-start
frequency when not
loaded

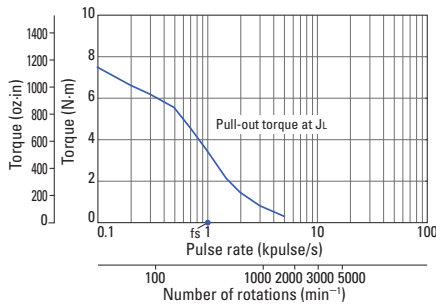

SH2863-5141
SH2863-5111

SM2863-5151
SM2863-5121

SM2863-5166

Constant current circuit
Source voltage: 100 VAC
Operating current:
4 A/phase, 2-phase
energization (full-step)
 $J_L = [44 \times 10^{-4} \text{kg} \cdot \text{m}^2 (240.56 \text{oz} \cdot \text{in}^2)]$ use the rubber
coupling)
 f_s : Maximum self-start
frequency when not
loaded

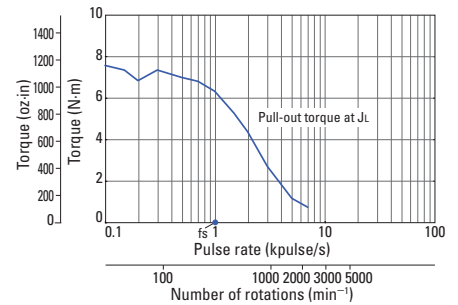

SH2863-5241
SH2863-5211

SM2863-5251
SM2863-5221

SM2863-5266

Constant current circuit
Source voltage: 100 VAC
Operating current:
6 A/phase, 2-phase
energization (full-step)
 $J_L = [44 \times 10^{-4} \text{kg} \cdot \text{m}^2 (240.56 \text{oz} \cdot \text{in}^2)]$ use the rubber
coupling)
 f_s : Maximum self-start
frequency when not
loaded

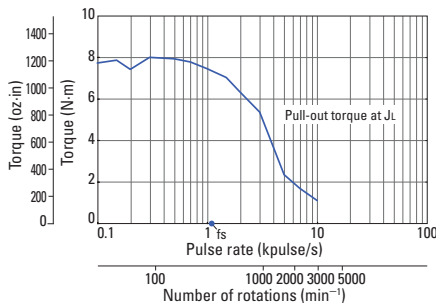

Dimensions [Unit: mm (inch)]

Lead wire type

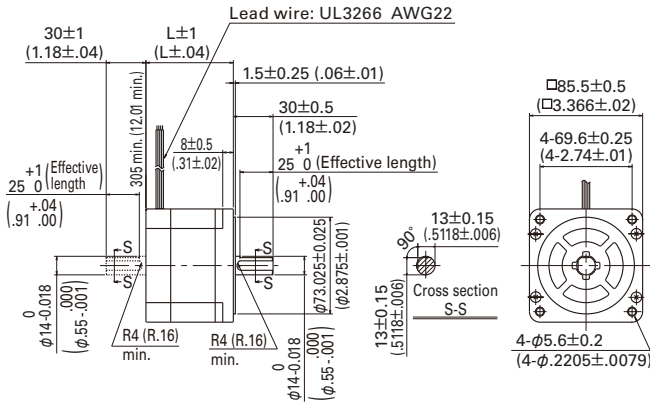

Terminal block type CE/UL model

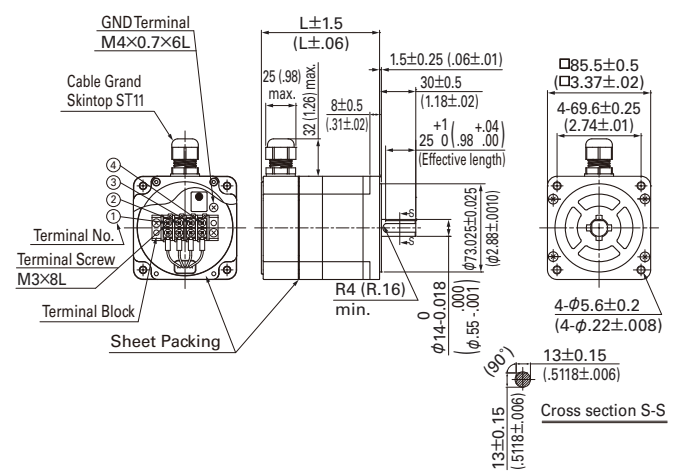

Lead wire type CE/UL model

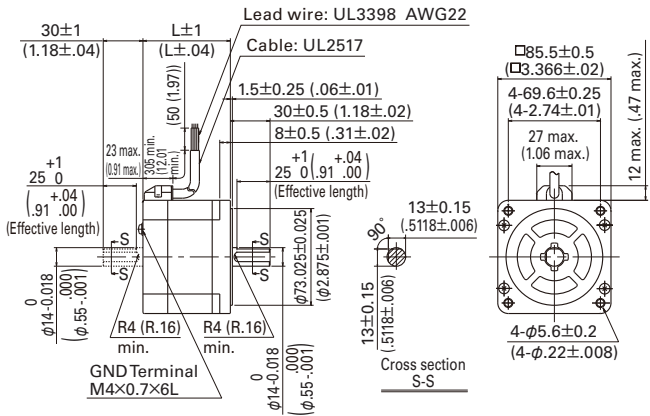

Internal wiring

Lead wire type

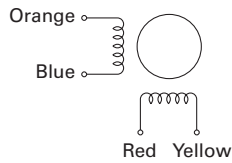

Terminal block type

() terminal block number

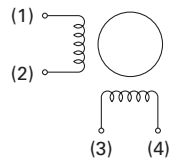

Compatible drivers

Driver is not included.

If you require assistance finding a driver, contact us for details.

Allowable Radial/Thrust Load

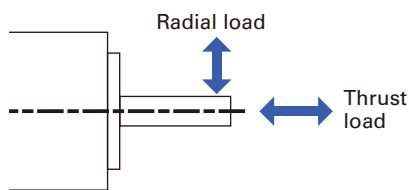

Flange size	Model number	Distance from end of shaft : mm (in)				Thrust load N (lbs)
		0	5	10	15	
Radial load : N (lbs)						
14 mm sq. (0.55 in sq.)	SH2141	10 (2.25)	11 (2.47)	13 (2.92)	-	0.7 (0.16)
28 mm sq. (1.10 in sq.)	SH228 □	42 (9)	48 (10)	56 (12)	66 (14)	3 (0.67)
35 mm sq. (1.38 in sq.)	SH353 □	40 (8)	50 (11)	67 (15)	98 (22)	10 (2.25)
42 mm sq. (1.65 in sq.)	103H52 □□ SH142 □	22 (4)	26 (5)	33 (7)	46 (10)	10 (2.25)
50 mm sq. (1.97 in sq.)	103H670 □	71 (15)	87 (19)	115 (25)	167 (37)	15 (3.37)
56 mm sq. (2.20 in sq.)	103H712 □	52 (11)	65 (14)	85 (19)	123 (27)	15 (3.37)
	103H7128	85 (19)	105 (23)	138 (31)	200 (44)	15 (3.37)
60 mm sq. (2.36 in sq.)	103H782 □	70 (15)	87 (19)	114 (25)	165 (37)	20 (4.50)
	SH160 □					15 (3.37)
86 mm sq. (3.39 in sq.)	SM286 □ SH286 □	167 (37)	193 (43)	229 (51)	280 (62)	60 (13.488)
	103H822 □					191 (43)
φ 106 mm (φ 4.17 in)	103H8922 □	321 (72)	356 (79)	401 (90)	457 (101)	100 (22.48)

Internal Wiring and Rotation Direction

Unipolar winding

Connector type Model number: 103H52 □□

Internal wire connection

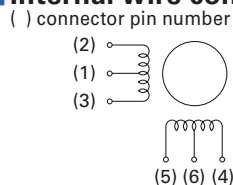

Connector type Model number: 103H782 □□

Internal wire connection

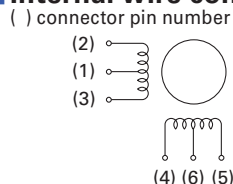

Lead wire type

Internal wire connection

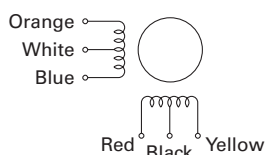

Direction of motor rotation

When excited by a direct current in the order shown below, the direction of rotation is clockwise as viewed from the output shaft side.

Exciting order	Connector pin number				
	(1.6)	(5)	(3)	(4)	(2)
1	+	-	-	-	-
2	+	-	-	-	-
3	+	-	-	-	-
4	+	-	-	-	-

Direction of motor rotation

When excited by a direct current in the order shown below, the direction of rotation is clockwise as viewed from the output shaft side.

Exciting order	Connector pin number				
	(1.6)	(4)	(3)	(5)	(2)
1	+	-	-	-	-
2	+	-	-	-	-
3	+	-	-	-	-
4	+	-	-	-	-

Direction of motor rotation

When excited by a direct current in the order shown below, the direction of rotation is clockwise as viewed from the output shaft side.

Exciting order	Lead wire color				
	White & black	Red	Blue	Yellow	Orange
1	+	-	-	-	-
2	+	-	-	-	-
3	+	-	-	-	-
4	+	-	-	-	-

Bipolar winding

Connector type

Internal wire connection

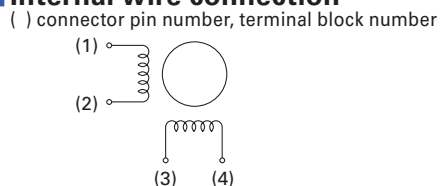

Lead wire type

Internal wire connection

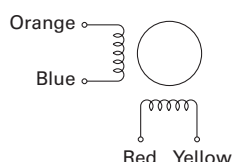

Direction of motor rotation

When excited by a direct current in the order shown below, the direction of rotation is clockwise as viewed from the output shaft side.

Exciting order	Connector pin number, terminal block number			
	(3)	(2)	(4)	(1)
1	-	-	+	+
2	+	-	-	+
3	+	+	-	-
4	-	+	+	-

Direction of motor rotation

When excited by a direct current in the order shown below, the direction of rotation is clockwise as viewed from the output shaft side.

Exciting order	Lead wire color			
	Red	Blue	Yellow	Orange
1	-	-	+	+
2	+	-	-	+
3	+	+	-	-
4	-	+	+	-

General Specifications

Motor model number	SH2141	SH228 □	SH353 □	SS242 □	SH142 □	103H52 □□	SS250 □	103H67 □□	103H712 □
Type	-								
Operating ambient temperature	- 10°C to + 50°C								
Conversation temperature	- 20°C to + 65°C								
Operating ambient humidity	20 to 90% RH (no condensation)								
Conversation humidity	5 to 95% RH (no condensation)								
Operation altitude	1000 m (3281 feet) max. above sea level								
Vibration resistance	Vibration frequency 10 to 500 Hz, total amplitude 1.52 mm (10 to 70 Hz), vibration acceleration 150 m/s ² (70 to 500 Hz), sweep time 15 min/cycle, 12 sweeps in each X, Y and Z direction.								
Impact resistance	500 m/s ² of acceleration for 11 ms with half-sine wave applying three times for X, Y, and Z axes each, 18 times in total.								
Insulation class	Class B (+130°C)								
Withstandable voltage	At normal temperature and humidity, no failure with 500 VAC @50/60 Hz applied for one minute between motor winding and frame.							At normal temperature and humidity, no failure with 1000 VAC @50/60 Hz applied for one minute between motor winding and frame.	
Insulation resistance	At normal temperature and humidity, not less than 100 MΩ between winding and frame by 500 VDC megger.								
Protection grade	IP40								
Winding temperature rise	80 K max. (Based on Sanyo Denki standard)								
Static angle error	± 0.09°				± 0.054°		± 0.09°		
Thrust play *1	0.075 mm (0.003 in) max. (load: 0.35 N (0.08 lbs))	0.075 mm (0.003 in) max. (load: 1.5 N (0.34 lbs))	0.075 mm (0.003 in) max. (load: 5 N (1.12 lbs))	0.075 mm (0.003 in) max. (load: 4 N (0.9 lbs))	0.075 mm (0.003 in) max. (load: 5 N (1.12 lbs))	0.075 mm (0.003 in) max. (load: 5 N (1.12 lbs))	0.075 mm (0.003 in) max. (load: 4 N (0.9 lbs))	0.075 mm (0.003 in) max. (load: 10 N (2.25 lbs))	0.075 mm (0.003 in) max. (load: 10 N (2.25 lbs))
Radial play *2	0.025 mm (0.001 in) max. (load: 5 N (1.12 lbs))								
Shaft runout	0.025 mm (0.001 in)								
Concentricity of mounting pilot relative to shaft	φ 0.05 mm (φ 0.002 in)	φ 0.05 mm (φ 0.002 in)	φ 0.075 mm (φ 0.003 in)	φ 0.075 mm (φ 0.003 in)	φ 0.05 mm (φ 0.002 in)	φ 0.05 mm (φ 0.002 in)	φ 0.075 mm (φ 0.003 in)	φ 0.075 mm (φ 0.003 in)	φ 0.075 mm (φ 0.003 in)
Squareness of mounting surface relative to shaft	0.1 mm (0.004 in)	0.1 mm (0.004 in)	0.1 mm (0.004 in)	0.1 mm (0.004 in)	0.1 mm (0.004 in)	0.1 mm (0.004 in)	0.1 mm (0.004 in)	0.1 mm (0.004 in)	0.1 mm (0.004 in)
Direction of motor mounting	Can be freely mounted vertically or horizontally								

Motor model number	SH160 □	103H78 □□	SH286 □	103H8922 □	SM286 □	103H712 □ -6 □□ 0 CE Model	103H822 □ -6 □□ 0 CE Model	103H8922 □ -63 □ 1 CE Model	
Type	-				S1 (continuous operation)				
Operating ambient temperature	- 10°C to + 50°C				- 10°C to + 40°C				
Conversation temperature	- 20°C to + 65°C				- 20°C to + 60°C				
Operating ambient humidity	20 to 90% RH (no condensation)				95% max.: 40°C max., 57% max.: 50°C max., 35% max.: 60°C max. (no condensation)				
Conversation humidity	5 to 95% RH (no condensation)								
Operation altitude	1000 m (3280 feet) max. above sea level								
Vibration resistance	Vibration frequency 10 to 500 Hz, total amplitude 1.52 mm (10 to 70 Hz), vibration acceleration 150 m/s ² (70 to 500 Hz), sweep time 15 min/cycle, 12 sweeps in each X, Y and Z direction.								
Impact resistance	500 m/s ² of acceleration for 11 ms with half-sine wave applying three times for X, Y and Z axes each, 18 times in total.								
Insulation class	Class B (+130°C)				Class F (+155°C)		Class B (+130°C)		
Withstandable voltage	At normal temperature and humidity, no failure with 1000 VAC @50/60 Hz applied for one minute between motor winding and frame.				At normal temperature and humidity, no failure with 1500 VAC @50/60 Hz applied for one minute between motor winding and frame.				
Insulation resistance	At normal temperature and humidity, not less than 100 MΩ between winding and frame by 500 VDC megger.								
Protection grade	IP40				IP43				
Winding temperature rise	80 K max. (Based on Sanyo Denki standard)								
Static angle error	± 0.054°		± 0.09°						
Thrust play *1	0.075 mm (0.003 in) max. (load: 10 N (2.25 lbs))								
Radial play *2	0.025 mm (0.001 in) (load: 5 N (1.12 lbs))	0.025 mm (0.001 in) (load: 5 N (1.12 lbs))	0.025 mm (0.001 in) (load: 5 N (1.12 lbs))	0.025 mm (0.001 in) (load: 10 N (2.25 lbs))	0.025 mm (0.001 in) (load: 5 N (1.12 lbs))	0.025 mm (0.001 in) (load: 5 N (1.12 lbs))	0.025 mm (0.001 in) (load: 5 N (1.12 lbs))	0.025 mm (0.001 in) (load: 10 N (2.25 lbs))	
Shaft runout	0.025 mm (0.001 in)								
Concentricity of mounting pilot relative to shaft	φ 0.075 mm (φ 0.003 in)								
Squareness of mounting surface relative to shaft	0.1 mm (0.004 in)	0.075 mm (0.003 in)	0.15 mm (0.006 in)	0.1 mm (0.004 in)	0.15 mm (0.006 in)	0.075 mm (0.003 in)	0.1 mm (0.004 in)	0.1 mm (0.004 in)	
Direction of motor mounting	Can be freely mounted vertically or horizontally								

*1 Thrust play: Shaft displacement under axial load.

*2 Radial play: Shaft displacement under radial load applied 1/3rd of the length from the end of the shaft.

Safety standards

Model Number: **SM286** □ CE/UL marked models

CE (TÜV)	Standard category		Applicable standard
	Low-voltage directives		EN60034-1, EN60034-5
UL	Acquired standards	Applicable standard	File No.
	UL	UL1004-1, UL1004-6	E179832
	UL for Canada	CSA C22.2 No.100	

Model Number: **103H712** □ -6 □□ 0, **103H822** □ -6 □□ 0, **103H8922** □ -63 □ 1 CE marked model

CE (TÜV)	Standard category		Applicable standard
	Low-voltage directives		EN60034-1, EN60034-5

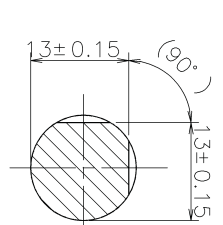
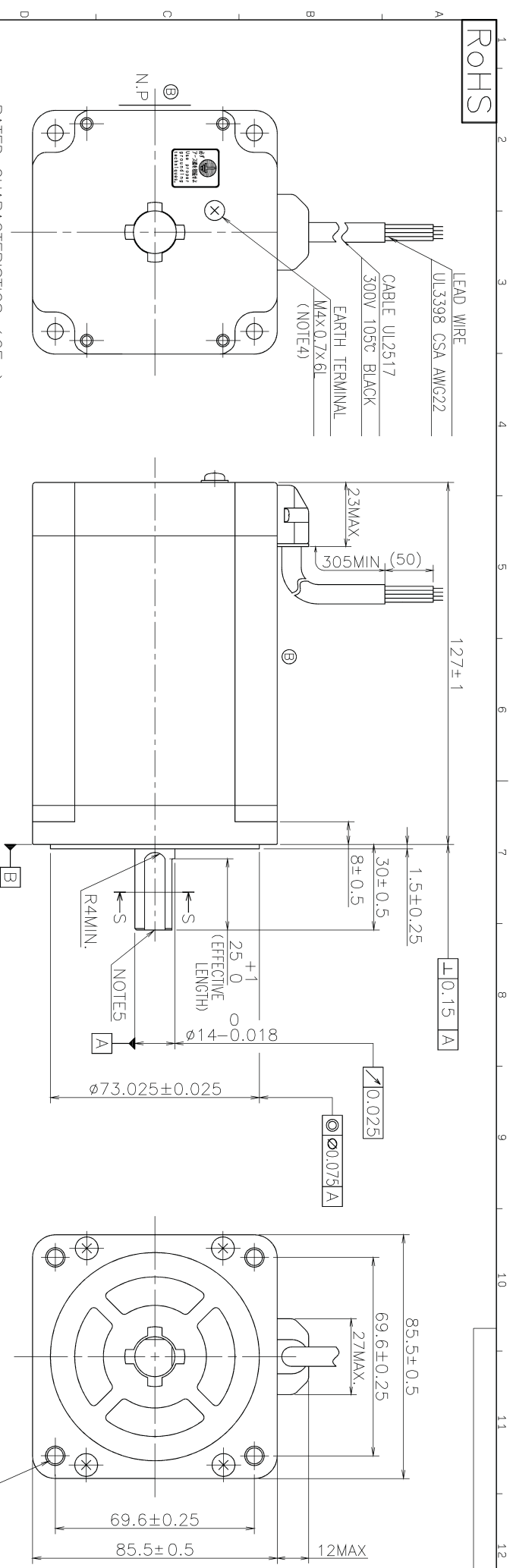

NOTE1. DRIVER INPUT VOLTAGE:
NOTE2. SANYO STANDARD 2PHASE EXCITATION DRIVE CIRCUIT WAS USED. (PMM-BA-4804) E=100V(AC).
NOTE3. MOUNT A MOTOR ON 200X200X16 ALUMINUM HEAT SINK AND ENERGIZE THE COIL AT 2 PHASE, I=4 A/PHASE CONSTANTLY. MEASURED BY THE CHANGE OF RESISTANCE METHOD.
NOTE4. TIGHTENING TORQUE OF THE SCREWS SHOULD BE 1±0.1 N · m.
NOTE5. CENTER HOLE ON THE SHAFT END IS NOT ALWAYS MADE.

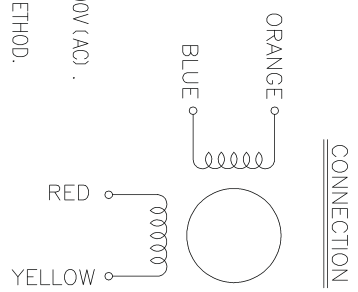

DIRECTION OF ROTATION
WHEN A MOTOR IS SEQUENCED AS SHOWN IN THE TABLE BELOW, THE SHAFT ROTATION MUST BE CLOCKWISE WHEN YOU SEE FROM SURFACE **B** SIDE.

LEADS COLOR			
1	RED	BLUE	YELLOW/ORANGE
2	⊖	⊖	⊖
3	⊕	⊕	⊕
4	⊖	⊖	⊖

承認	承認	承認	承認
DATE	DATE	DATE	DATE
05-12-01	05-09-02	05-12-01	05-12-06
ED0073067	NEW DESIGN	A	
山洋電気株式会社			山洋電気株式会社
SANYO DENKI CO.,LTD.			SANYO DENKI CO.,LTD.
A26-F-1			A26-F-1
SM2863-5151			SM2863-5151
STEPPING MOTOR			STEPPING MOTOR