



92×92×38 mm

San Ace 92AD 9AD type

General Specifications

- Material Frame: Plastic (Flammability: UL 94V-0), Impeller: Plastic (Flammability: UL 94V-0)
- Expected life See the table below. (L10 life: 90% survival rate for continuous operation in free air at 60°C, rated voltage)
- Motor structure Brushless DC motor
- Motor protection function Locked rotor burnout protection, Reverse polarity protection
For details, please refer to p. 547.
- Dielectric strength 50/60 Hz, 1500 VAC, for 1 minute (between input terminal and frame, and between sensor output and frame)
- Insulation resistance..... 10 MΩ or more with a 500 VDC megger
- Sound pressure level (SPL) At 1 m away from the air inlet
- Storage temperature -30 to +75°C (Non-condensing)
- Mass 250 g

Do not solder wires directly to AC input terminals.

Specifications

The models listed below **have ribs and no sensors**. For models without ribs, append "1" to the end of model numbers.

Model no.	Rated voltage [V]	Operating voltage range [V]	Frequency [Hz]	Rated current [A]	Rated input [W]	Rated speed [min ⁻¹]	Max. airflow [m ³ /min] [CFM]	Max. static pressure [Pa] [inchH ₂ O]	SPL [dB (A)]	Operating temperature [°C]	Expected life [h]
9AD0901H12	100 to 240	90 to 264	50/60	0.08	4.5	3850	1.5 53.0	90 0.36	40	-20 to +75	60000/60°C
9AD0901M12				0.06	3.0	3100	1.18 41.7	56 0.22	33		

The models listed below **have ribs and low-speed sensors**. For models without ribs, append "1" to the end of model numbers.

Model no.	Rated voltage [V]	Operating voltage range [V]	Frequency [Hz]	Rated current [A]	Rated input [W]	Rated speed [min ⁻¹]	Max. airflow [m ³ /min] [CFM]	Max. static pressure [Pa] [inchH ₂ O]	SPL [dB (A)]	Operating temperature [°C]	Expected life [h]
9AD0901H1H	100 to 240	90 to 264	50/60	0.08	4.5	3850	1.5 53.0	90 0.36	40	-20 to +75	60000/60°C
9AD0901M1H				0.06	3.0	3100	1.18 41.7	56 0.22	33		

Set Models

Fan, finger guard, plug cord, screws, etc. can be purchased in one package. For details, please refer to p. 594.

Order no.	Set items					
	Fan	Voltage	Low-speed sensor	Plug cord	Finger guards	Mounting screws
ST1-9AD0901H12	9AD0901H12	100 to 240 V		489-1635-L10	109-099E	M4×55 mm (4 screws)
ST1-9AD0901M12	9AD0901M12			489-1635-L10	109-099E	
ST1-9AD0901H1H	9AD0901H1H		○	489-1635-L10	109-099E	
ST1-9AD0901M1H	9AD0901M1H		○	489-1635-L10	109-099E	

Airflow - Static Pressure Characteristics

9AD0901H12, 9AD0901H1H

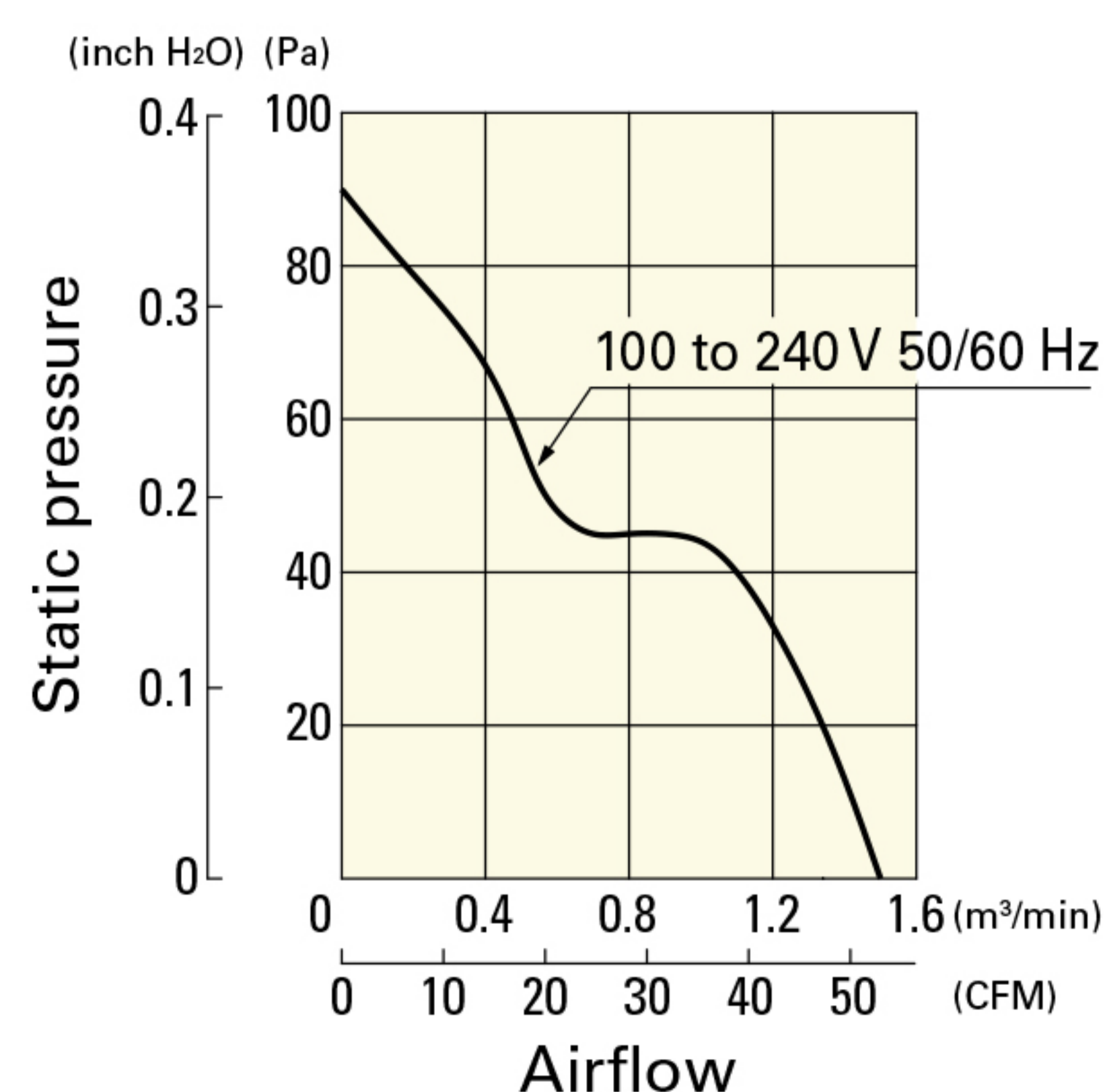

9AD0901M12, 9AD0901M1H

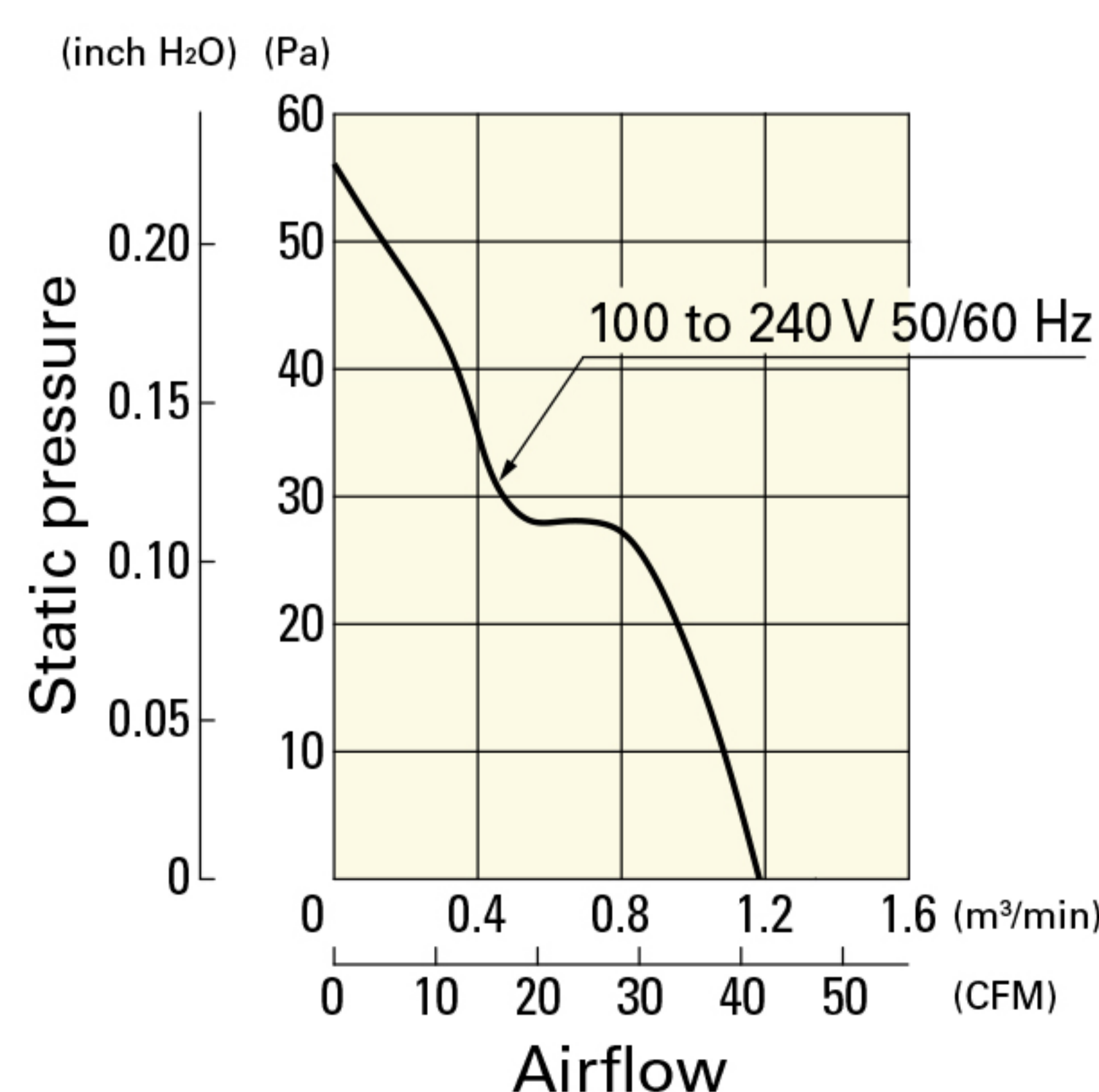

without Sensor

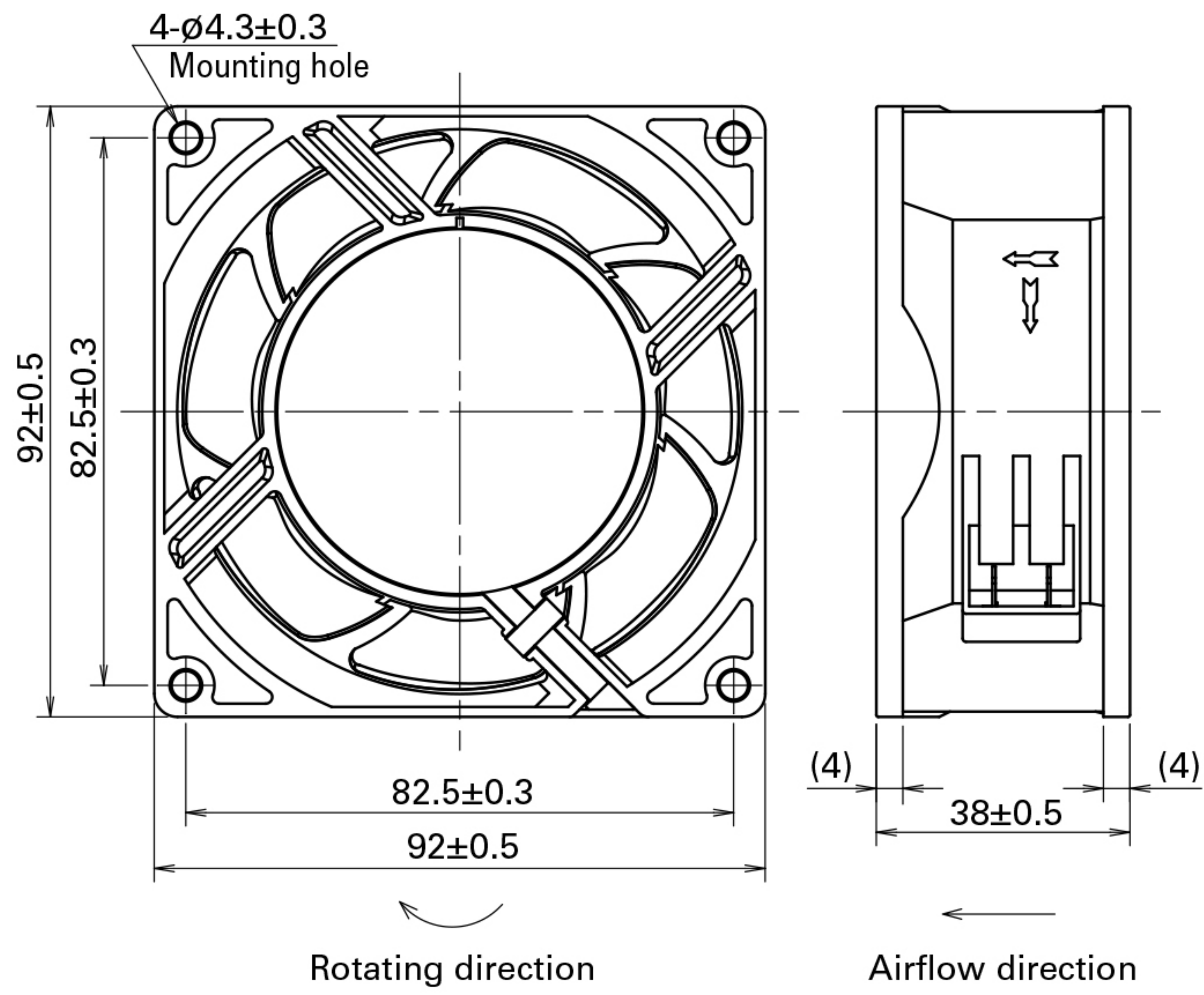

with Low-speed sensor

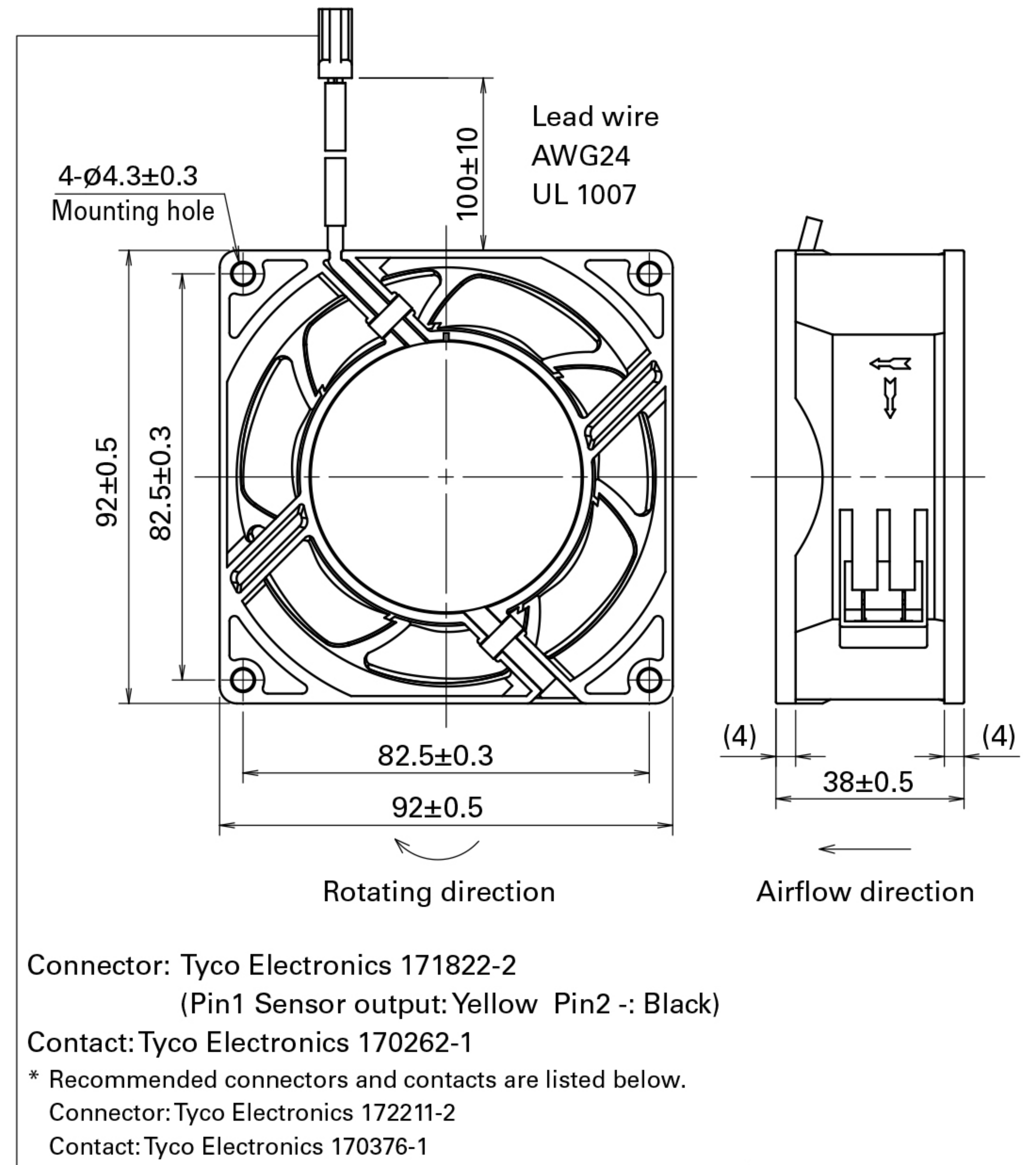

Reference Dimensions of Mounting Holes and Vent Opening (unit: mm)

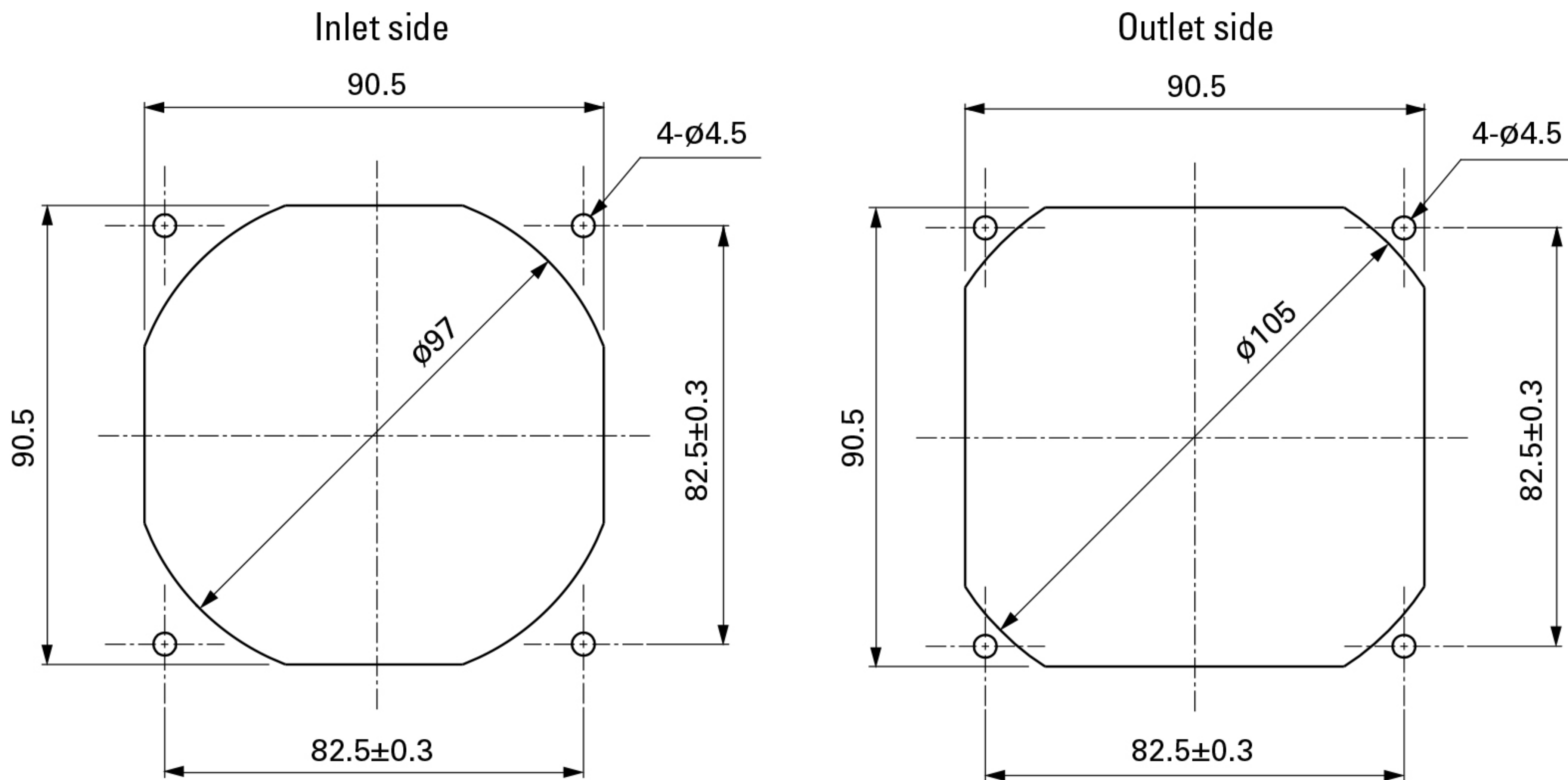

Wiring Diagram

without Sensor

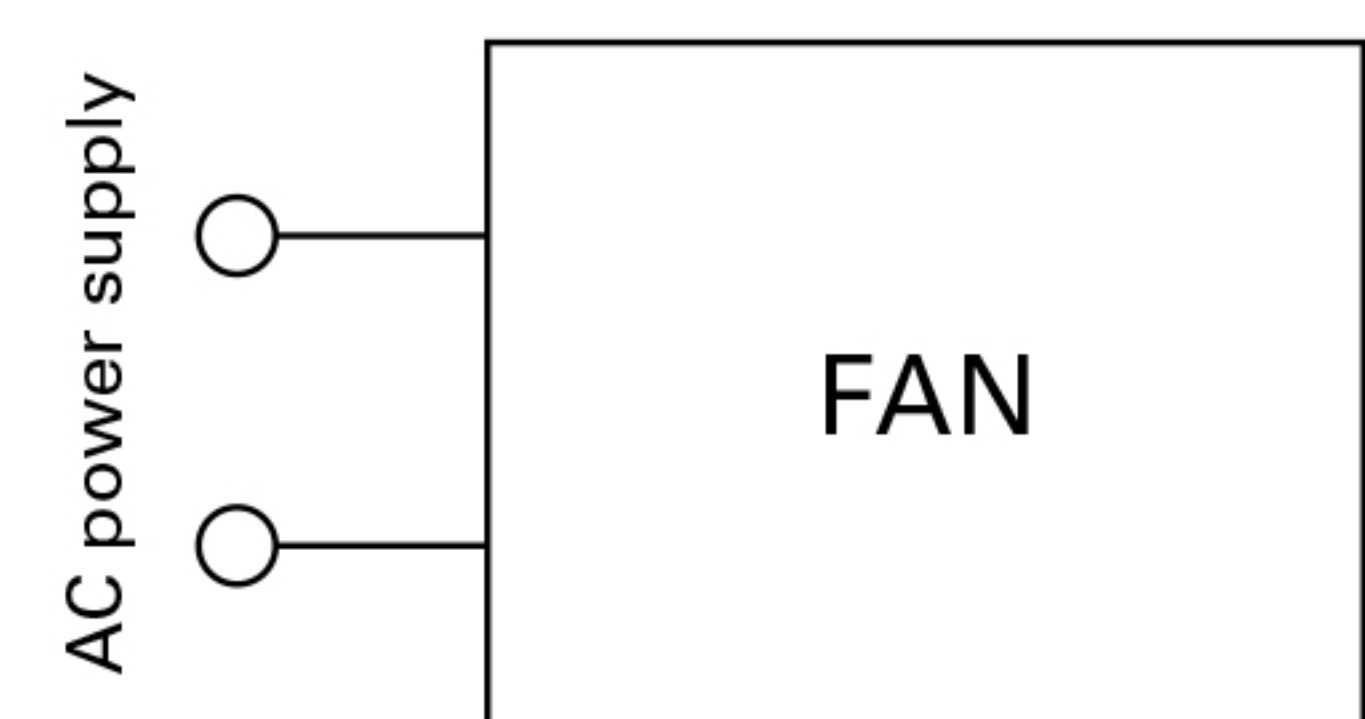

with Low-speed sensor

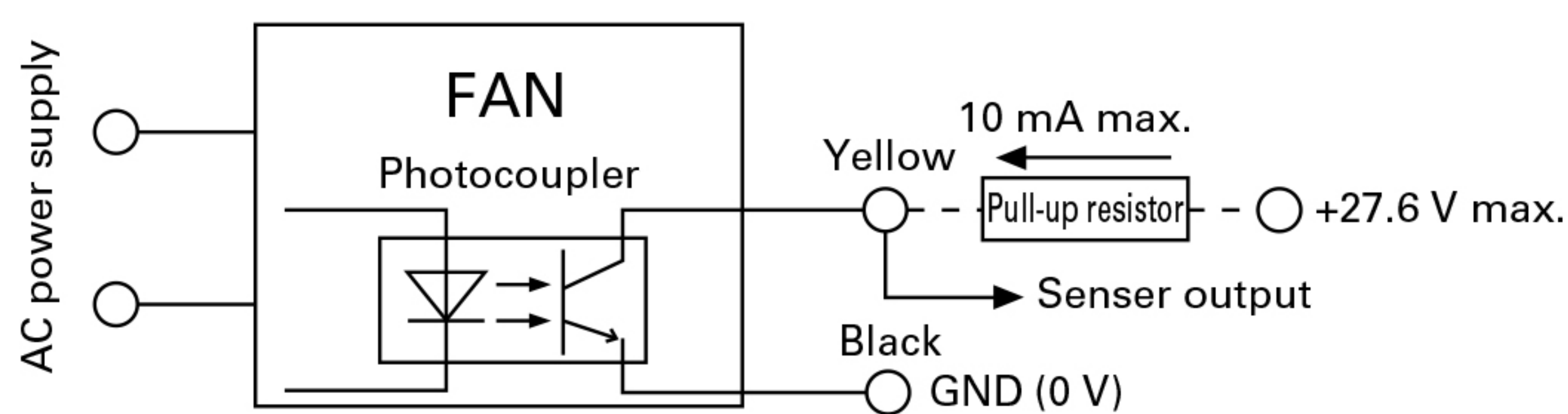

Specifications for Low-speed Sensors

Typical standard model: 9AD0901H1H

Output circuit: Open collector

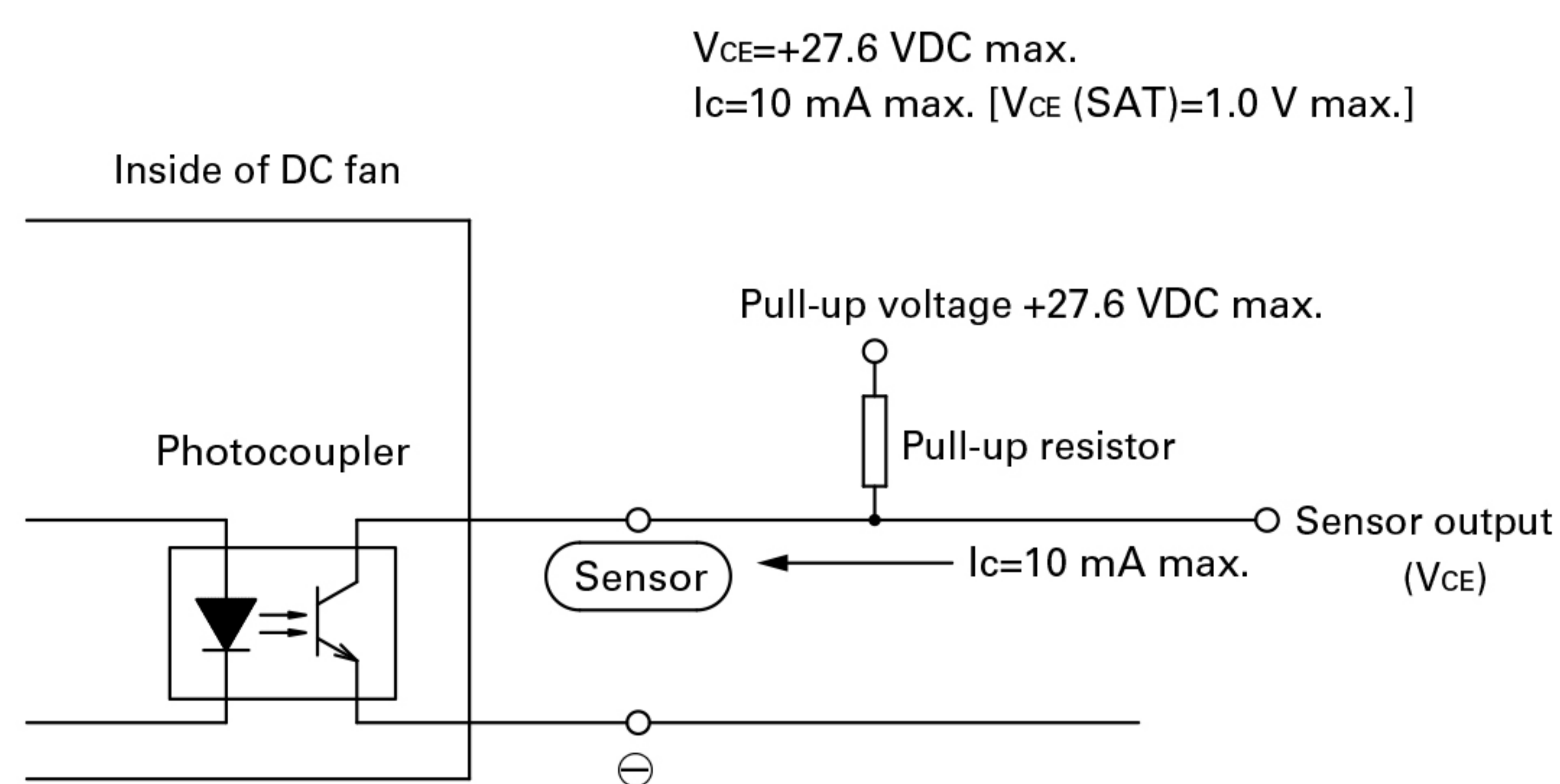

Sensor scheme

Example 1: when steady running

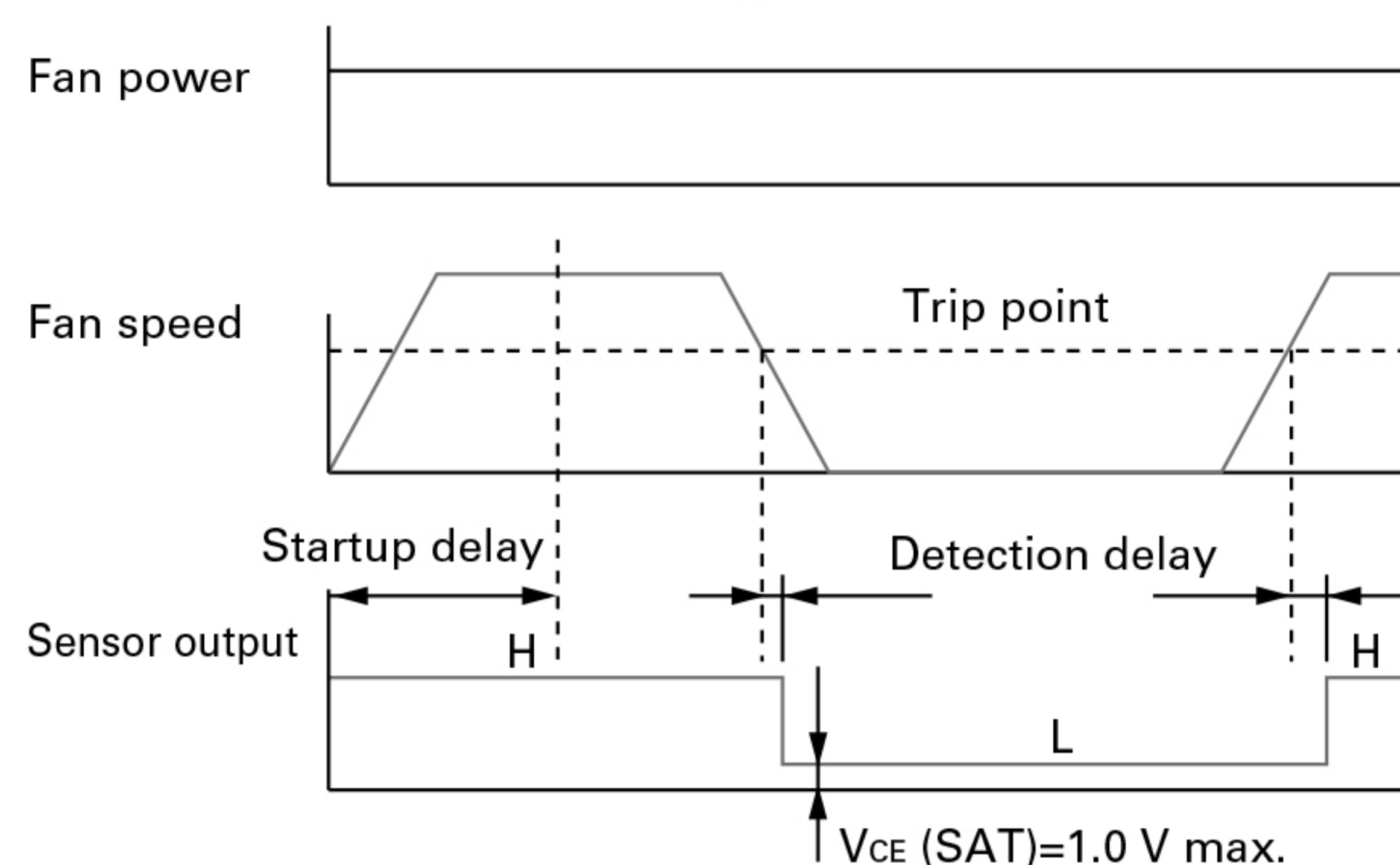

Example 2: when the rotor is locked when the fan motor is turned on and released after the start-up delay time.

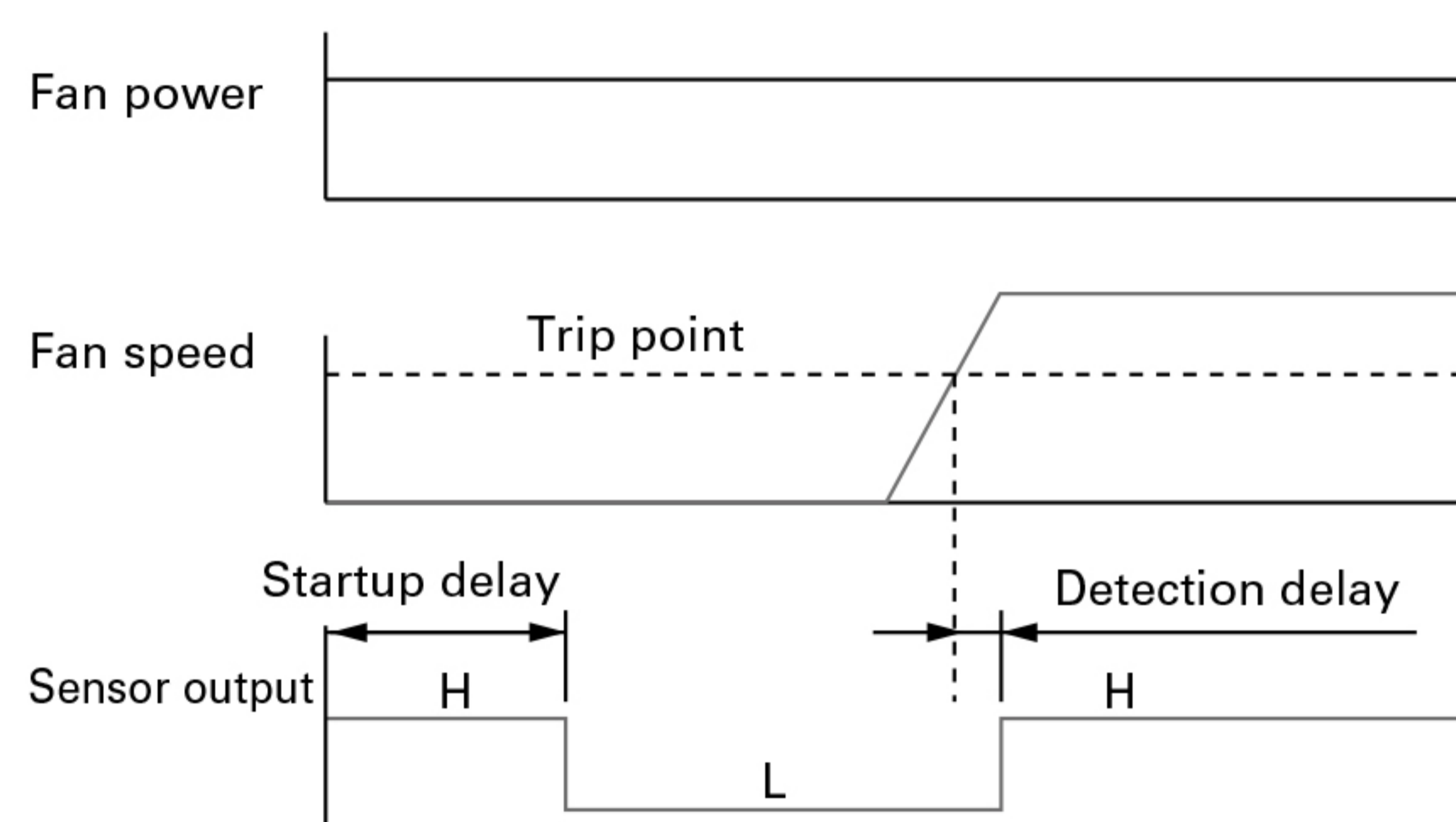

9AD0901H1H

Startup delay: $18 \pm 3 \text{ s}$

Detection delay: 3 s max.

Trip point: 1700 min^{-1}

9AD0901M1H

Startup delay: $36 \pm 3 \text{ s}$

Detection delay: 3 s max.

Trip point: 850 min^{-1}

Options

Finger guards

page: p. 532

Model no.: 109-099C, 109-099E, 109-099H

Resin finger guards

page: p. 539

Model no.: 109-1001G

Resin filter kits

page: p. 540

Model no.: 109-1001F13 (13PPI), 109-1001F20 (20PPI),
 109-1001F30 (30PPI), 109-1001F40 (40PPI)

Plug cord

page: p. 543

Model no.: 489-1635-L10, 489-1635-L21

Wiring harness for sensor

page: p. 543

Model no.: 489-1636