

Dimensions (unit: mm)

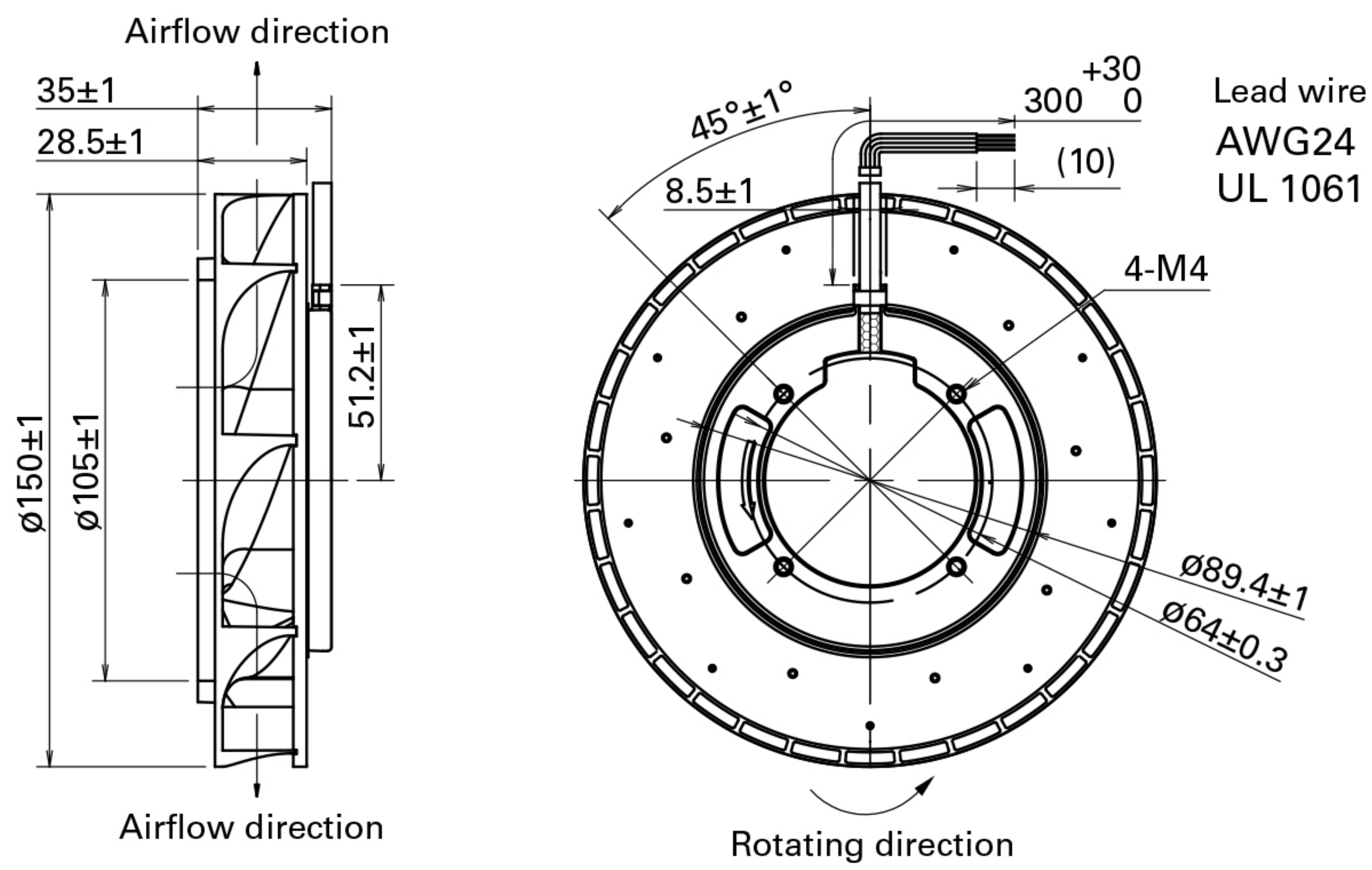

Reference Dimensions of Mounting Holes and Vent Opening (unit: mm)

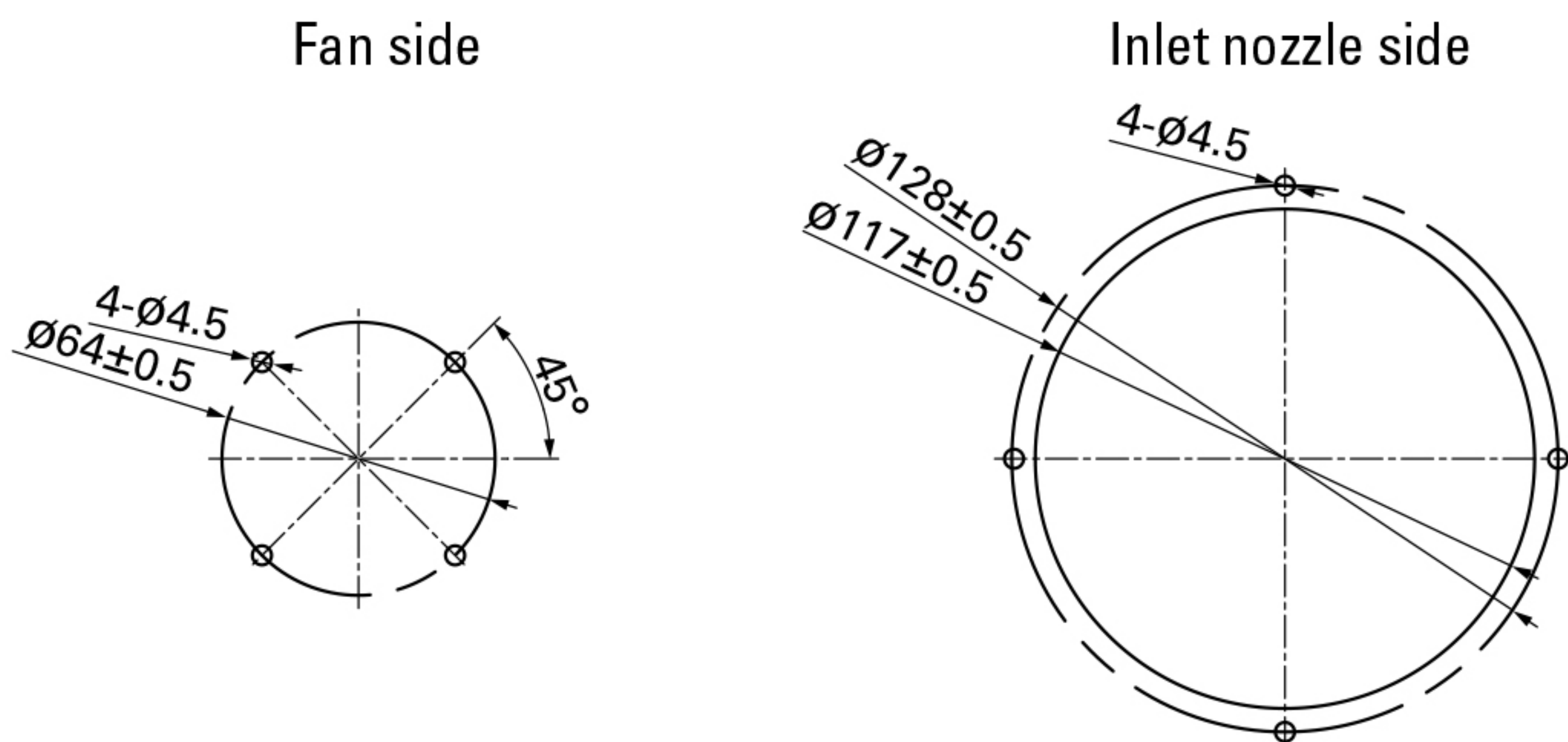

Reference Diagram for Mounting

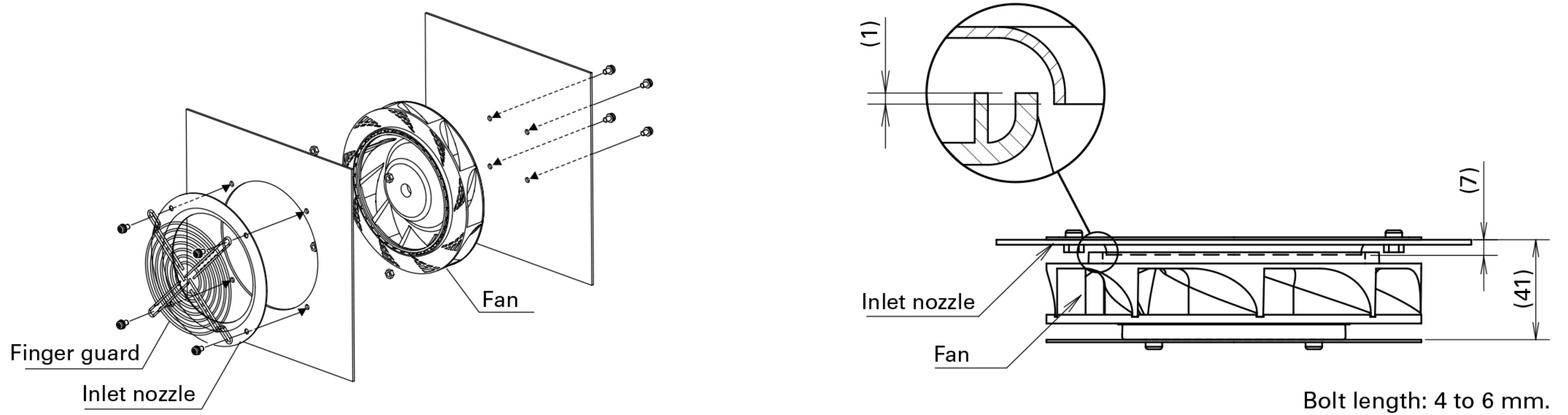

Options

Finger guards

page: p. 533

Model no.: 109-1104, 109-1104H

Inlet nozzle

page: p. 537

Model no.: 109-1081, 109-1081H

DC

Splash Proof Centrifugal Fan Ø150 mm