

# 规格承认书

## SPECIFICATION FOR APPROVAL

客户名称 CUSTOMER: \_\_\_\_\_  
客户料号 PARTS No.: \_\_\_\_\_ S700 \_\_\_\_\_  
承认编号 APPROVAL No.: \_\_\_\_\_ CR-20170710001 \_\_\_\_\_  
风扇型号 FAN MODEL: \_\_\_\_\_ D1611N-05W-B05 \_\_\_\_\_  
散热器型号 COOLER MODEL: \_\_\_\_\_  
样品数量 QTY: \_\_\_\_\_ 1PCS \_\_\_\_\_ 日期 DATE: \_\_\_\_\_ 2017.07.10 \_\_\_\_\_

客户承认用印栏 APPROVED SIGNATURES

PLEASE RETURN ONE COPY WITH YOUR APPROVED SIGNATURES.

APPROVED	CHECKED	PREPARED
杨慧斌	杨慧斌	付彪

北京三鼎中天科技有限公司

# 规格

## SPECIFICATIONS

风扇型号 FAN MODEL: D1611N-05W-B05

01 额定电压 Rated Voltage	: 24V
02 额定电流 Rated Current	: $0.16 \pm 0.02A$
03 额定转速(常温)Rated Speed	: $13000RPM \pm 15\%$
04 起动电压 Start-up Voltage	: 12V
05 额定功率 Rated Power	: 3.84W
06 风量 AirFlow	: 20.0CFM
07 电压范围 Operating Voltage Range	: 20.4V~27.6V
08 静压 Static pressure	: 18.0mmH <sub>2</sub> O
09 音量位准 Noise level	: 49.0dBA
10 运转温度 Operating Temperature	: $-10^{\circ}C \sim 70^{\circ}C$
11 保存温度 Storage Temperature	: $-40^{\circ}C \sim 70^{\circ}C$
12 轴承 Bearing System(NMB)	: Ball Bearing
13 重量 Weight	: 36g
14 寿命 Life-Time	: 50000HR

1	风扇框 (Frame)	PBT UL 94V-0 Black
	风扇叶 (Blade)	PBT UL 94V-0 Black
	线架 (Bobbin)	PBT UL 94V-0
2	轴承 (Bearing)	Ball Bearing
3	引线1 (Lead Wire)	UL1007 26AWG框外300mm
4	端子 (Connector)	光二线
		黑红分线

## 外观图 OUTLINE

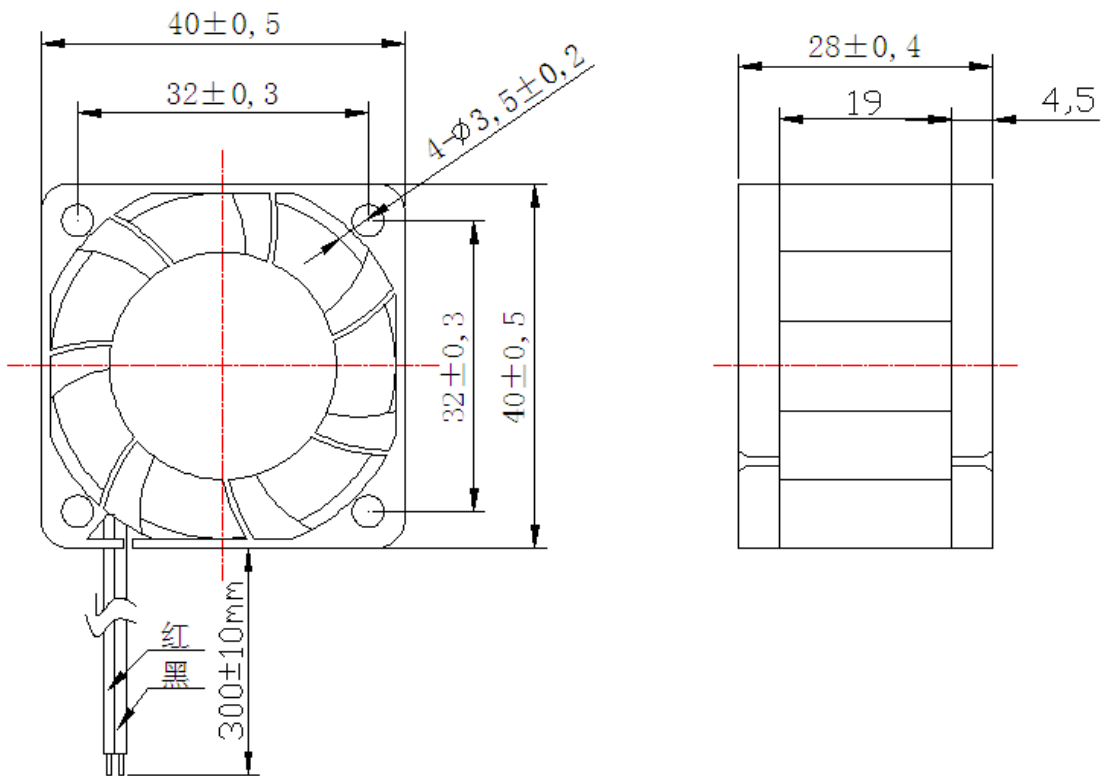

风扇风量风压特性图

Air Flow(CMM)

