



产 品 规 格 书

SPECIFICATION FOR APPROVE

机型 MODEL: R19092N-05W-B7T

品名 NAME: DC Brushless Impeller

客户代码: J000

北京三鼎中天科技有限公司

生产地址: 河北省三河市燕郊经济开发区百世金谷二期 W1-Q

Tel:010-80843596 Fax:010-80843598-8031

Web:www.cnecport.com Email:postmaster@cnecport.com

SPECIFICATIONS

1、 Bearing System	2 Ball Bearing
2、 Rated Voltage	24VDC
3、 Operating Voltage	16 ~ 28VDC
4、 Starting Voltage	16VDC
5、 Input Current	3.6A
6、 Input Power	86.4W
7、 Rated Speed	3000RPM
8、 Rotation	Clockwise,seen on rotor
9、 Air Flow	294.8CFM (500.9 m ³ /h)
10、 Static Air Pressure	1.97inH ₂ O (50.03 mmH ₂ O)
11、 Soft Start	Yes
12、 Speed Control	PWM or 0 ~ 10VDC
13、 Tachometer Output	Open collector,3 Pulses/Rev
14、 Auto Restart	Yes
15、 Alarm Output	No
16、 Noise Level	62dB(A)
17、 Lead Wire	UL , AWM1007,AWG20#,500mm
18、 Connector	No
19、 Ambient temperature	-20 ~ 60°C
20、 Life Expectance	40,000Hours continuous operating at 25°C
21、 Insulation class	“A”
22、 Operation mode	Continuous operation (SI)
23、 Type of protection	IP 42
24、 Number of blades	16
25、 Dielectric Strength	1500VAC,1 min,Leakage current<=3.5mA
26、 Net Weight	1348g
27、 Packing	Corrugated carton, 12 pcs/carton

NO.3 性能曲线图 Performance Curves

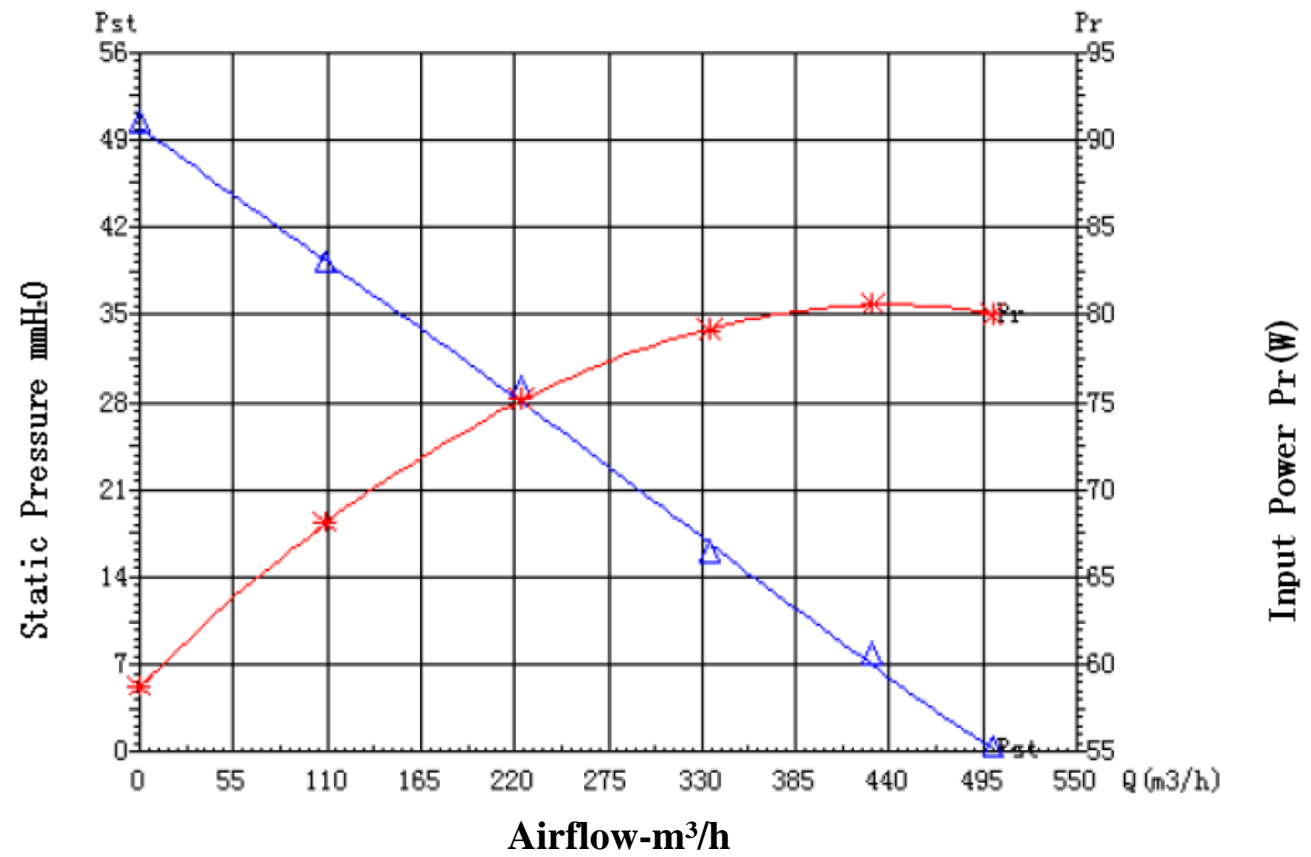
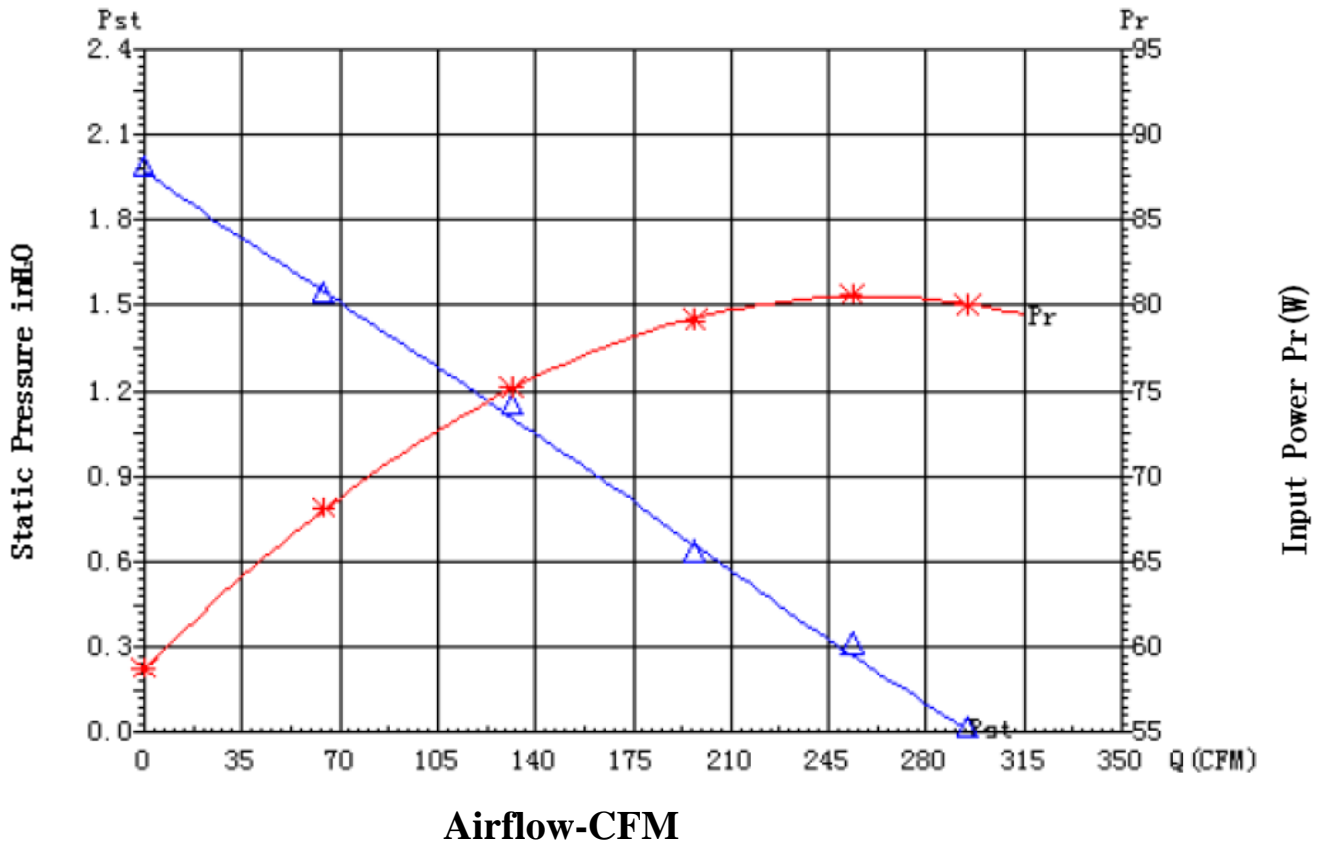

NO.4 连接方式 Connection Methods

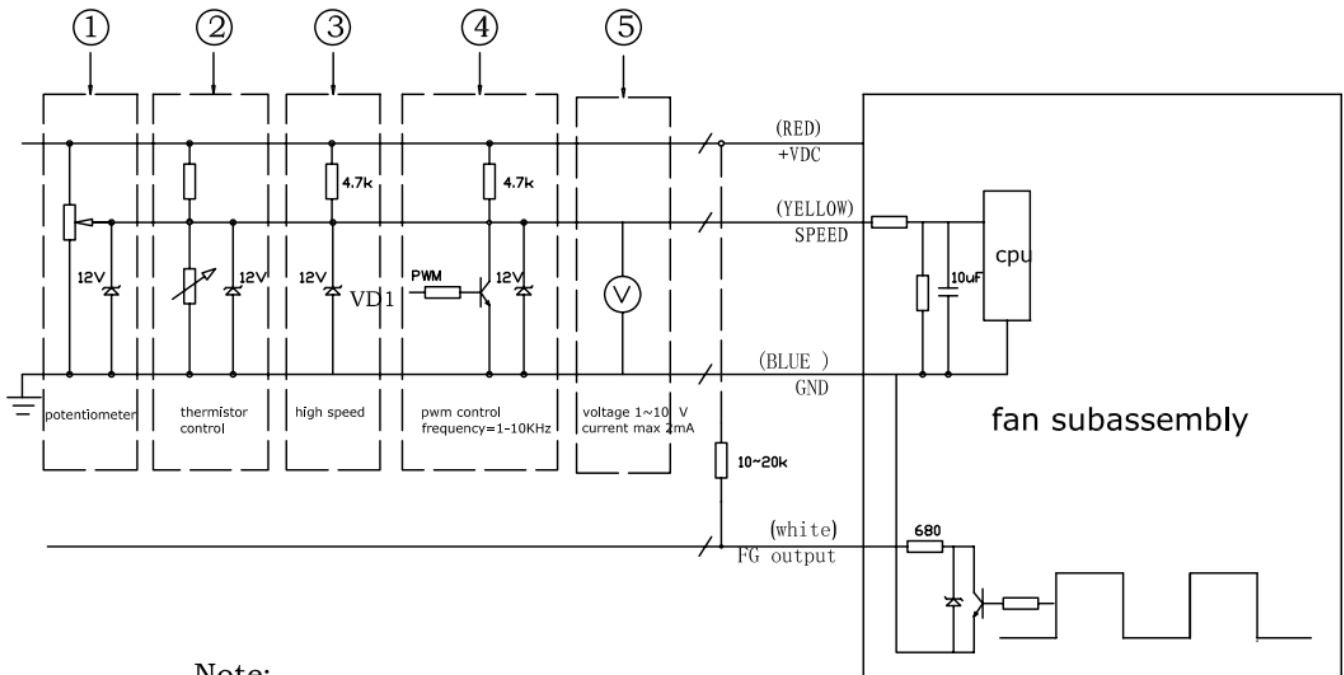

Note:

1. Above outside circuit connecting sketches are the five kinds of most common speed control circuits;
2. The third connecting method has not speed adjusting function. You don't need to connect it with VD1 component when voltage under or at 12V.

NO.5 外形图 Product Outline

