

## 产 品 规 格 书

## Product specification

名 称(NAME): 后倾式离心风机 backward curved centrifugal fan

型 号(MODEL): R22592E-38W-B23

客户代码(CUSTOMER CODE):

版本号(VERSION NUMBER): A/0

编 制 (Prepared): 吴玲佳 2016.1.21

校 对 (Checked): 刘鑫波 2016.1.21

审 核 (Reviewed):

批 准 (Approved): 2016.1.21

客户确认 (CUSTOMER'S APPROVAL):

日 期 (DATE): 2016.1.22

## 换版记录 Description of Revision

版本号 Version No.	换版原因 Notes & Remarks	换版内容 reason content	修订人 Revised by	日期 Date
A/0	/	/	/	/

## 1.0 概述/ Introduction

本规格书主要描述了产品标准、使用环境、技术要求等。

This specification describes the standards, operating environment, and technic requirements of the product.

## 2.0 产品标准和安规要求/Requirements of product standards and safety regulations

### 2.1 本产品符合的标准 / The product satisfy requirements

#### 2.1.1 GB12350 《小功率电动机的安全要求》

GB12350 《Safety requirments of small power motors》

#### 2.1.2 GB/T13275 《一般用途离心通风机通用技术条件要求》

GB/T13275 《General technical requirements for general centrifugal fan》

#### 2.1.3 EN60335-1 《家电和类似用途电器的安全要求》

EN60335-1 《Safety requirements of household and similar electrical appliances》

### 2.2 本产品通过 CCC、CE 认证

The fan is CCC, CE approved.

### 2.3 本产品全部材料符合 RoHS 要求

All materials are RoHS compliant.

## 3.0 机械要求/ Mechanical requirements

### 3.1 外形图/Dimensioned drawing

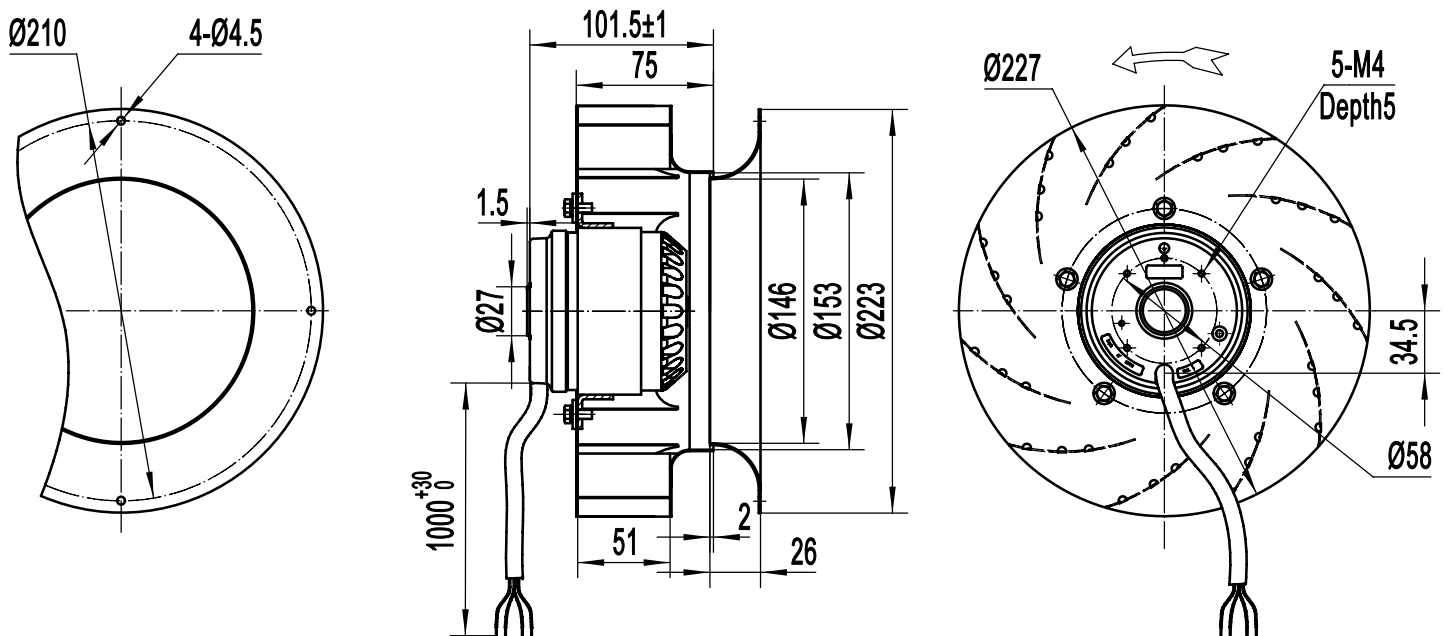

### 3.2 材质/Materials

转子铸铝;风轮镀锌板

Rotor: Aluminum Casting; Impeller: Steel Sheet

### 3.3 电机/Motor

外转子交流电机/ External rotor AC motor

### 3.4 电机型号/Motor type

YWM092-025-24-2T-AF0

### 3.5 轴承/ball bearing

免维护滚珠球轴承/ Maintenance free ball bearing

### 3.6 平衡/Balancing

风机在额定电压和频率下运转时，每个端面动平衡精度不低于G6.3，符合标准JB/T9101。  
The residual unbalance weight is less than the permit value of G6.3 (balancing precision grade, according to the standard of JB/T9101) when the fan is running at rated voltage and frequency.

### 3.7 振动/Vibration of the fan

风机振动速度有效值按照JB/T8689标准规定。

Vibration speed virtual value of fans accord with JB/T8689.

### 3.8 跳动/ Runout of impeller

风轮轴向、径向跳动  $\leq 1\text{mm}$ 。

Runout of impeller in axial and radial direction  $\leq 1\text{mm}$ 。

### 3.9 寿命/Life time

风机寿命估算值20000小时，（在额定电压、环境温度为40℃、风机全速运转时）

The designed lifespan of the fan is 20000 hours assuming the fan is running at rated voltage, full speed and 40 degrees C environmental temperature.

### 3.10 产品净重/Net Weight

Net weight: 2.2Kg

## 4.0 风机性能/Fan performance

### 4.1 性能参数/Performance data

额定电压/ Voltage[V]	频率/ Frequency[ Hz ]	电容/ Capacitor[ $\mu$ F ] ( $\pm 5\%$ )	输入电流/ Current draw [ A ] ( $\pm 10\%$ )	输入功率/ Power input[W] ( $\pm 10\%$ )	转速/ Speed[r/min] ( $\pm 10\%$ )	风量/ Air flow/(OPa ) [ m <sup>3</sup> /h]( $\pm 10\%$ )	噪音/ Noise level [ Lp dB(A)]
380	50	/	0.18	102	2150	900	68

### 4.2 特性曲线/Performance curve(s)

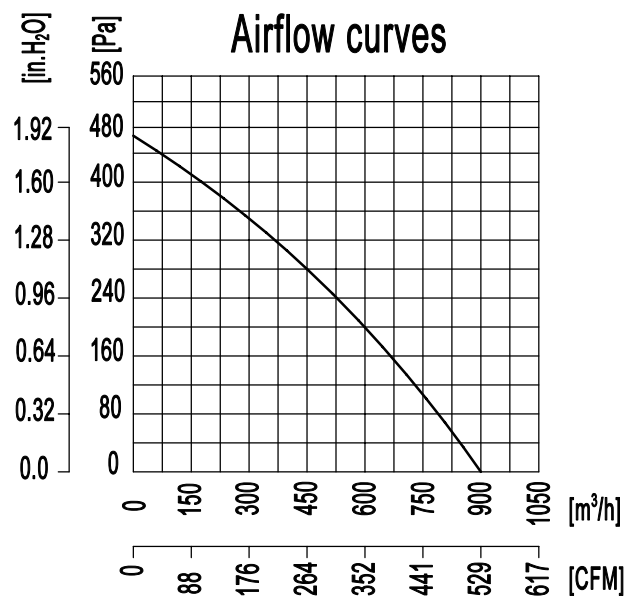

## 5.0 电气性能/Electrical performance

### 5.1 铭牌/Label (选中请打勾/Please tick at your choice)

中文/chinese

	<b>R22592E-38W-B23</b> 三相异步外转子风扇电动机		
	380V 50Hz 0.18A 102W 2150RPM CL.F IP44 20xx.xx.xx-x		

英文/english

	<b>R22592E-38W-B23</b> THREE-PHASE FAN MOTOR		
	380V 50Hz 0.18A 102W 2150RPM CL.F IP44 20xx.xx.xx-x		

### 5.2 接线图/Wiring diagram (选中请打勾/Please tick at your choice)

中文/chinese

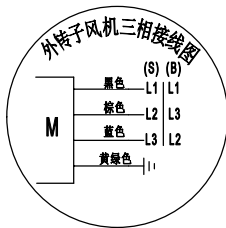

英文/english

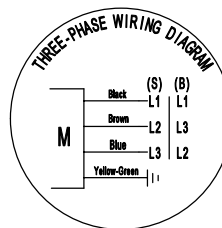

### 5.3 电压范围/Voltage range

风机设计的额定运行电压为380V，可运行的电压范围是342~418V。

The fan is designed to operate at a nominal voltage of 380V, but it can be operated in the range of 342-418V.

### 5.4 保护/Protection

电机有热保护功能，断开温度:150—160℃,复位温度:90—120℃

This motor has overheated protection function, cut off temperature is between 150—160℃ and reset temperature is between 90—120℃.

### 5.5 防护等级: IP 44

Protection Class: IP44.

### 5.6 绝缘等级: F

Insulation Class: F

### 5.7 工作制/Type of Application

S1  S2  其他/Other

### 5.8 安装方式/ Installation Mode

水平/Horizontal  垂直/Vertical  其他/Other

### 5.9 调速方式/Mode of speed regulation

斩波/PWM  变频/VFD  抽头/By Wiring  电容/Capacitor  无极调速/Stepless  无/NA

## 6.0 质量要求/Quality Requirements

质量要求符合ISO9001:2000和企业标准。

Quality requirements accord with ISO9001:2000 and Dunli's quality standards.

## 7.0 使用和存储环境/ Operating and storing environmental requirements

### 7.1 使用环境/ Operating environmental requirements

使用温度范围/Operating temperature range:  $-30^{\circ}\text{C} \sim +60^{\circ}\text{C}$

使用湿度范围/Operating humidity range:  $0\% \sim 90\% \text{ RH}$

海拔高度/Operating altitude:  $\leq 1000\text{m}$

### 7.2 贮存环境/Storing environmental requirements

贮存温度范围:  $-10^{\circ}\text{C} \sim +40^{\circ}\text{C}$  , 贮存湿度范围:  $0\% \sim 75\% \text{ RH}$ 。

Storing temperatures range:  $-10^{\circ}\text{C} \sim +40^{\circ}\text{C}$  ; Storing humidity range:  $0\% \sim 75\% \text{ RH}$ 。

## 8.0 包装和标识/ Packaging and marks

### 8.1 包装/Packaging

泡沫包装/Foam packaging

### 8.2 标识/Marks

制造商名称、产品型号、重量、尺寸等

Markings: Name of manufacturer, fan model , date of production, weight, dimensions, etc.

## 9.0 附件/Other requirements on accessories

### 9.1 电容/Capacitor

■带/Yes, □不带/No, □根据销售订单配备/As per sales' requirement.

### 9.2 连接件要求/Connector

连接器/Connecter(□有/Yes, ■没有/No),                    型号/Modle:

端子/Terminal(□有/Yes, ■没有/No),                    型号/Modle: