

# 产 品 规 格 书

## Product Specification

名 称(NAME): 后倾式离心风机 Backward Curved Centrifugal Fan

型 号(MODEL): R28137E-38W-B23/D000

客户代码(CUSTOMER CODE): D000

版本号(VERSION NUMBER): A/0

编 制 (Prepared): 余丽华

校 对 (Checked): 郝玉成

批 准 (Approved): 叶国洲

客户确认 (CUSTOMER'S APPROVAL) : \_\_\_\_\_

日 期 (DATE): \_\_\_\_\_

### 换版记录 Description of Revision

版本号 Version No.	换版原因 Notes & Remarks	换版内容 Contents	修订人 Revised by	日期 Date
A/0	/	/	/	/

1.0 概述/ Introduction

本规格书主要描述了产品标准、使用环境、技术要求等。

This specification describes the standards, operating environment, and technical requirements of the product.

2.0 产品标准和安规要求/Requirements of product standards and safety regulations

2.1 本产品符合的标准 / Standards and requirements of the product followed

2.1.1 GB12350 《小功率电动机的安全要求》

GB12350 《Safety requirements of small power motors》

2.1.2 EN60335-1 《家电和类似用途电器的安全要求》

EN60335-1 《Safety requirements of household and similar electrical appliances》

2.2 本产品通过 CCC、CE 认证

The fan is CCC、CE approved.

2.3 本产品全部材料符合 RoHS 要求

All materials are RoHS compliant.

3.0 机械要求/ Mechanical requirements

3.1 外形图/Dimensioned drawing

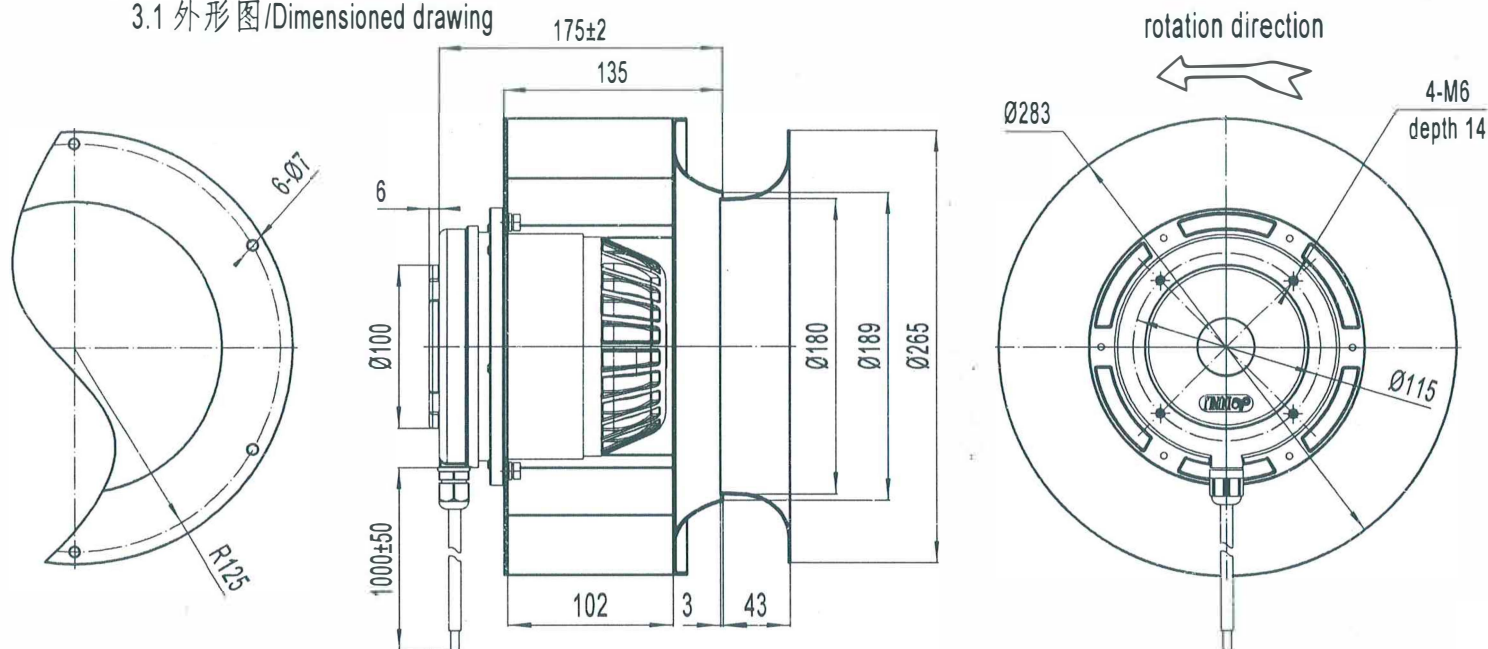

3.2 风机材质/ Fans Materials

3.2.1 风轮材质/ Impeller Material

Aluminium alloy / 铝合金
  Plastics / 塑胶
  Others / 其它

3.2.2 电机磁材/ Motor magnetic materials

高强度漆包铜线 QZ-2 180°C/ High strength enamelled wire QZ-2 180°C

硅钢/ Stator and Rotor permeability magnetic material: Silicon Steel

转子: 铸铝/ Rotor: Die-Casting Aluminium

3.3 电机类型/ Motor Type

外转子交流电机/ External rotor AC motor

3.4 轴承/ Bearing

免维护滚珠球轴承/ Maintenance free ball bearing

3.5 平衡/ Balancing

风机在额定电压和频率下运转时，每个端面动平衡精度不低于 G6.3，符合标准 JB/T9101。

The residual unbalance weight is less than the permit value of G6.3 (balancing precision grade, according to the standard of JB/T9101) when the fan is running at rated voltage and frequency.

3.6 振动/Vibration

风机振动速度有效值按照JB/T8689标准规定。

Vibrating speed virtual value of fans is in accord with JB/T8689.

3.7 寿命/Lifespan

风机寿命估算值20000小时，（在额定电压、环境温度为40℃、额定负载运转时）

The designed lifespan of the fan is 20000 hours assuming the fan is running at rated voltage, rated load and 40 degrees C environmental temperature.

3.8 产品净重/Net Weight: 8kg.

4.0 风机性能/Fan performance

4.1 电压范围/Voltage range

风机设计的额定运行电压为380V，可运行的电压范围是342~418V，

The fan is designed to operate at a nominal voltage of 380V, but it can be operated in the range of 342~418V

4.2 性能参数/Performance data

额定电压 Voltage[V]	频率 Frequency[ Hz ]	电容 Capacitor [uF] (±5%)	输入电流 Current draw [A] (±10%)	输入功率 Power input[W] (±10%)	转速 Speed[r/min] (±10%)	风量 Air flow/(0Pa) [ m3/h](±10%)	噪音 Noise level [ Lp dB(A)]	数据状态 Tyap of data definition
380/400	50	/	1.3	500	2750	2600	78	fa

数据状态: fa: 放空状态(带风轮自由运行)；ml: 最大负载点；me: 最大效率点；cs: 客户要求；cu: 客户机箱中。

Definitions of data: fa: Running at free air; ml: Max load; me: Max efficiency; cs: Customer request; cu: Customer unit.  
(Subject to alterations)

4.3 铭牌和特性曲线/Nameplate & Performance curve(s)

中文/chinese



英文/english

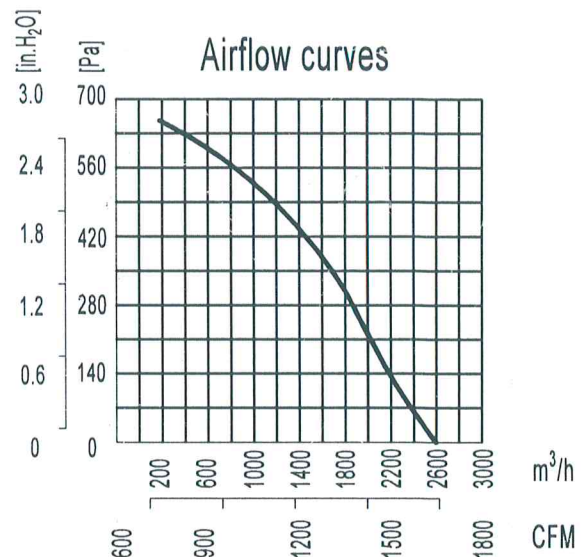

4.4 接线图/Wiring diagram

中文/chinese

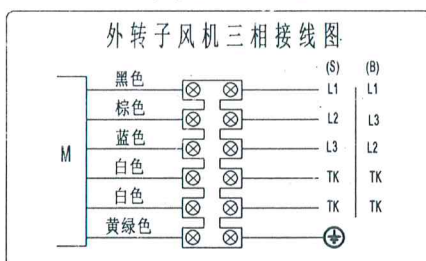

英文/english

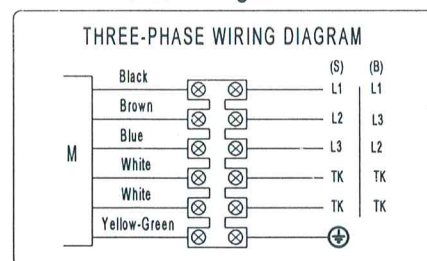

## 5.0 电气要求/Electrical requirements

## 5.1 保护/Protection

电机有热保护功能, 断开温度:150—160℃,复位温度:90—120℃

This motor is equipped with the overheated protection function, cut off temperature is between 150--160℃ and reset temperature is between 90—120℃.

## 5.2 防护等级: IP54

Protection Class: IP54

## 5.3 绝缘等级: F

Insulation Class: F

5.4 工作制/Type of Application :  S1  S2  其他/Other

## 5.5 安装方式/Installation Mode

 水平/Horizontal 垂直/Vertical 其他/Other

## 5.6 调速方式/Mode of speed regulation

斩波/PWM  变频/VFD  抽头/By Wiring  电容/Capacitor  无极调速/Stepless  无/NA

## 6.0 质量要求/Quality Requirements

质量要求符合ISO9001:2000和企业标准.

Quality requirements are in accord with ISO9001:2000 and Ke feng's quality standards.

## 7.0 使用和存储环境/Operating and storing environmental requirements

## 7.1 使用环境/Operating environmental requirements

使用温度范围/Operating temperature range: -30℃ ~ +50℃

使用湿度范围/Operating humidity range: 0% ~ 90% RH

海拔高度/Operating altitude: ≤ 1000m

环境大气压力80-110Kpa / Ambient atmospheric pressure: 80-110Kpa;

## 7.2 贮存环境/Storing environmental requirements

最佳贮存温度范围: -30℃ ~ +60℃, 贮存湿度范围: 0% ~ 75% RH。

Storing suitable temperatures range: -30C ~ +60C. Storing humidity range: 0% ~ 75% RH。

## 8.0 包装和标识/Packaging and marks

## 8.1 包装/Packaging

纸箱包装/Carton packaging

## 8.2 标识/Marks

制造商名称、产品型号、重量、尺寸等

Markings: Name of manufacturer, fan model, date of production, weight, dimensions, etc.

## 9.0 附件/Other requirements on accessories

## 9.1 电容/Capacitor

带/Yes,  不带/No,  根据销售订单配备/As per sales' requirements.

## 9.2 连接件要求/Connector

连接器/Connector(有/Yes, 没有/No),

型号/Modle:

端子/Terminal(有/Yes, 没有/No),

型号/Modle:

## 10. 使用注意事项 Operation Attentions:

- 10.1 不适用具有甲烷混合气体和煤尘爆炸危险的煤矿井下;  
Can not be used in coal mine wells in which there are methane mixed gas and coal that may cause dust explosion hazard;
- 10.2 不适用于有强烈冲击、振动的地方;  
Should be stored at and used for these places where have no strong impact force and shock;
- 10.3 不适用于有明显破坏绝缘的气体或蒸汽的环境中;  
Can not be used for these places where have corrosive gas or steam existing;
- 10.4 无对电机漆包线寿命损坏之波形输入,防止冲击电压破坏产品;  
No these wave inputs allowed which might reduce enameled, in order to prevent, the product from damage by the impact voltage
- 10.5 移动产品时请勿拉扯电源引线,避免线路断裂或绝缘受损,同时避免叶片受力。  
Void the circuit from break down and/or insulation from damage, Please do not pull the wire, harnesses while moving the product, and avoid any force loading on the blades.
- 10.6 风机安装必须由专业人员完成;  
The installation of motor fan must be performed by professionals;
- 10.7 安装前,应仔细校核铭牌、接线图所列各项数据是否符合您的要求,检查紧固件是否有松动;确认无误后,方可安装使用;  
Please check the nameplate, wiring diagram and the specification data of the fan to make sure the fan meets your application check all the fastening parts to make sure there's no any looseness existing; requirements before installation;
- 10.8 安装时确保风机转动无卡滞现象;风机启动时,观察风机转向是否与标识一致;  
Please check to make sure there's no clamping stagnation with the fan before installation;  
Please check the rotation direction of the fan to make sure it's running the correct direction;
- 10.9 要求用户风机设备可靠接地;  
Customer fan unit should connect to ground well;
- 10.10 风机在运转时不可将异物伸入风机运转范围内;  
Reaching into the fan blade area is forbidden when the fan is running;
- 10.11 按本规格书中的参数评价产品,若工作参数发生变更,请与本公司联系  
Please use this product under the conditions specified on this specification, and please contact with us if your application is in the applied conditions
- 10.12 售后服务 After-sales service  
凡本公司生产的风机,自购买之日起,质保期一般为壹年(以订货合同为准),质保期内凡制造质量问题,用户可凭销售发票或保修卡,与公司经销商联系。  
The guarantee time of our fans is one (1) year usually (For special conditions, in accordance to the contract) from the invoice date. Please contact with our agent whom, the fan you purchased from if there's any quality issue during guarantee period.

## 11. 其它 Others

- 11.1 本产品的知识产权属于本公司 在本产品的使用上不会发生专利问题 应用本产品形成有关产品或方法及新的技术方案造成专利侵权 本公司不予保证 请贵公司特别注意  
We have intellectual rights on this product, We are not responsible for any tort/patent disputes caused by us this product on other products/technical solutions.
- 11.2 贵公司保证未经本公司许可 不得将此技术规格书泄漏给其它任何第三方  
It should be assured that this specification can not be revealed to any third party without the consent of our corporation
- 11.3 声明  
请注意上述所有内容,否则由此引起的一切质量问题与事故由用户自行承担。  
Please pay attention to all the above contents. Otherwise, customer should undertake the due obligation for all the quality issues and accidents.