

产 品 规 格 书

PRODUCT SPECIFICATION

名 称 (NAME): 交流离心风机 AC centrifugal fan型 号 (MODEL): R31102E-12L-B41客户代码 (CUSTOMER CODE): D000版 本 号 (VERSION NUMBER): A/0

编 制 (MAKE): _____

审 核 (CHECKED): _____

批 准 (APPROVED): _____

客户确认 (CUSTOMER APPROVE): _____

日 期 (DATE): _____

换版记录Describing of Alternations

版本号/Version	换版原因/ Alternations reason	换版内容/ Alternations reason content	姓名/ Name	日期 /Date
A/0	/	/	梁炳光	2009-10-31

1.0 概述/ Introduction

本规格书主要描述了产品标准、使用环境、技术要求等.

This specification describes the standard、operation environment、and technic requirements of the product.

2.0 产品标准和安规要求/Requirement of production standard and safety regulations

2.1 本产品符合的标准 / The product satisfy requirements

2.1.1 GB12350 《小功率电动机的安全要求》

GB12350 《Safety requirments of small power motors》

2.1.2 GB/T13275 《一般用途离心通风机通用技术条件要求》

GB/T13275 《General technical requirement for general centrifugal fan》

2.2.3 EN60335-1 《家电和类似用途电器的安全要求》

EN60335-1 《Household and similar electrical appliances-safety》

2.2 本产品通过 CCC、CE 认证

The fan has CCC、CE Safety regulations certificate.

2.3 本产品全部材料符合 RoHS 和 REACH 要求

All material accord with RoHS and REACH.

3.0 使用环境/ Operating environment requirements

3.1 工作温度和湿度/ Operating temperature and humidity

工作温度范围: $-30^{\circ}\text{C} \sim +60^{\circ}\text{C}$., 工作湿度范围: $0\% \sim 90\% \text{RH}$.

Operating temperatures from -30°C to $+60^{\circ}\text{C}$, Operating humidity from 0% to $90\% \text{RH}$.

3.2 贮存温度和湿度/Storing temperature and humidity

贮存温度范围: $-40^{\circ}\text{C} \sim +60^{\circ}\text{C}$, 贮存湿度范围: $0\% \sim 90\% \text{RH}$.

Storing temperatures from -40°C to $+60^{\circ}\text{C}$; Storing humidity from 0% to $90\% \text{RH}$.

4.0 机械要求/ Mechanical requirements

4.1 外形图/Dimension drawing

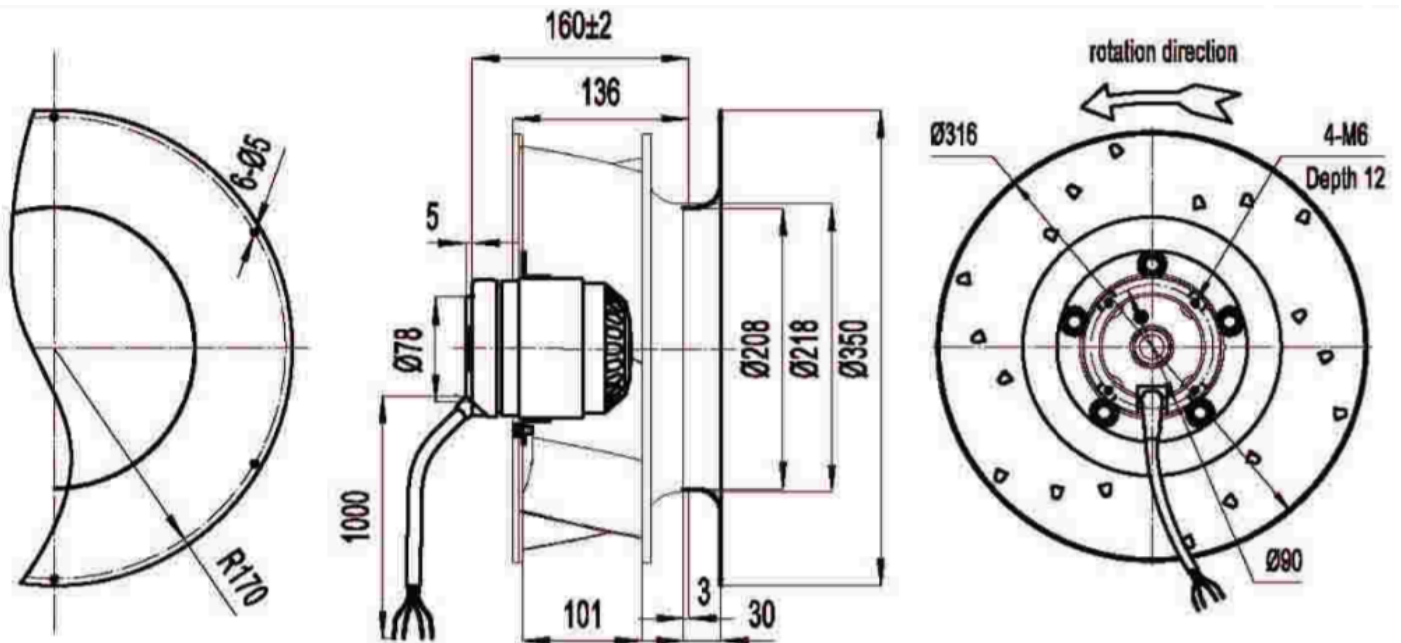

4.2 叶轮/Impeller

叶轮由PA66塑料制成。

Impeller made of plastic PA66.

4.3 电机/Motor

外转子鼠笼式电机。

External rotor squirrel-cage motors

4.4 平衡/ Balancing

风机在 $2950 \pm 50\text{r/min}$ 运转时，每个端面动平衡精度不低于 G6.3，符合标准 JB/T9101。

At $2950 \pm 50\text{r/min}$ running speed, the residual unbalance of the fan is not less than G6.3 (balancing precision grade) in each plane, according with JB/T9101.

4.5 振动/Vibration of the fan

风机振动速度有效值按照JB/T8689标准规定。

Vibration speed virtual value of fans accord with JB/T8689.

4.6 跳动/ Runout of impeller

风轮轴向、径向跳动 $\leq 1.2\text{mm}$ 。

Runout of impeller in axial and radial direction $\leq 1.2\text{mm}$ 。

4.7 防护等级/Type of protection

风机的防护等级为IP54。

Type of protection is IP54.

4.8 寿命/Life time

风机寿命估算值40000小时，(在额定电压、环境温度为 40°C 、风机全速连续运转时)

Fan life expectance 40000 hours, determined when at nominal supply voltage, running at full speed, environment temperature of 40°C 。

5.0 风机性能(高/中/低档)/Fan performance

5.1 标称参数/Rating data

额定电压 Voltage[V]	频率 Frequency [Hz]	起动电容 Starting capacitor[$\mu\text{F}/\text{v}$]	输入电流 Current draw [+10%A]	输入功率 Powerinput [+10%W]	转速 Speed [-10%r/min]	风量 Air flow [-10 m^3/h]	噪音 Noise level [dB(A)]	绝缘等级 Insulation class
115	60	16/250	1.60	180	1600	2000	66	F

5.2 特性曲线(高/中/低)/Performance curve(H/M/L) (额定工作电压 115V 时/Rating voltage 115V)

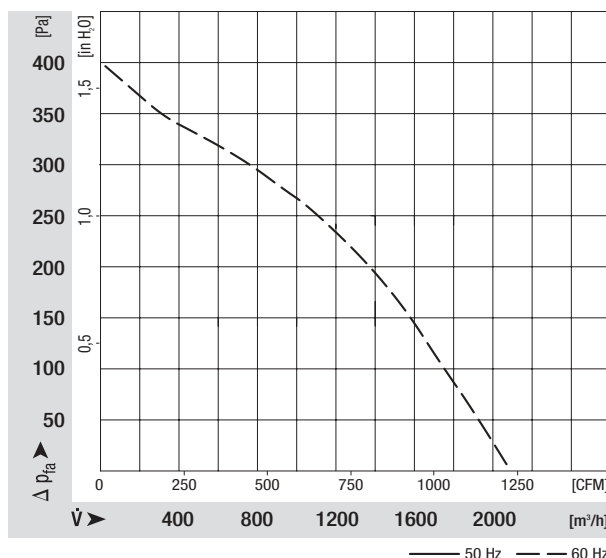

6.0 电气性能/Electrical performance

6.1 接线示意图/View lead connection

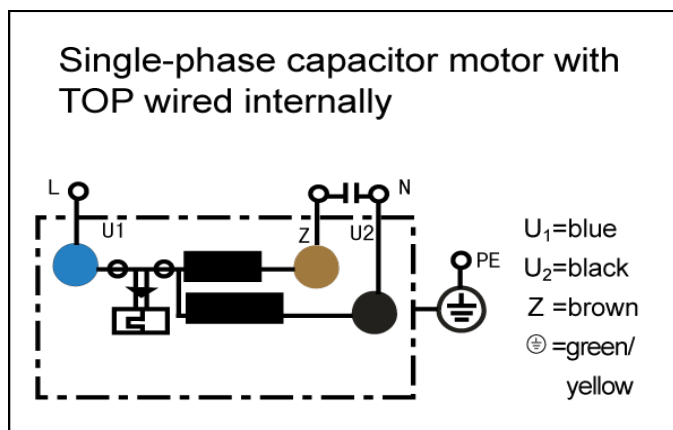

6.2 电压范围/Voltage range

风机设计的额定运行电压为115V，可运行的电压范围是100~135V，

The fan is designed to operate at a nominal voltage of 115V but can be operated in the supply voltage range of 100to 135 V.

6.3 保护/Protection

电机有热保护功能，断开温度:150—160℃，复位温度:90—120℃

This motor with heat protection, cut off temperature: 150—160℃, replacement temperature 90—120℃

7.0 质量要求/Quality requests

质量要求符合企业标准 / Quality requests accord with SAN-DING standard

8.0 产品标识/Product marks

8.1 SAN-DING 标志/ Logo SAN-DING

要/ Yes, 取消/ No

8.2 铭牌标识/Nameplate drawing:

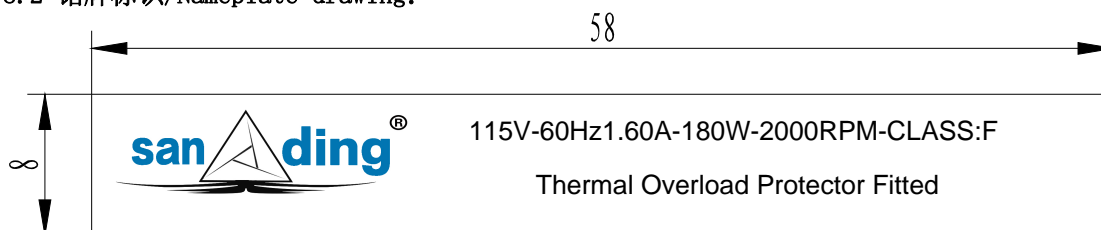

9.0 包装和标识/ Packaging and marks

9.1 包装/Packaging

包装必须有确定的尺寸和合适的结构确保风机在运输过程中不会损坏。

The packaging has to be well dimension and structure, so that the fans for on normal transport could not be damaged.

9.2 标识/Marks

制造商名称、产品型号、重量、尺寸等

Markings: Name of manufacturer, type of fan, date of manufacture, weight, Size etc.

10.0 附件/Other requirements on accessory

10.0.1 导风圈/ Inlet cones 带/ Yes, 不带/ No,

10.0.2 电容/Capacitor 带/Yes, 不带/No;

10.0.3 网罩/Net cover (有/YES、没有/NO) 蜗壳材料为/Scroll housing Material:

10.0.4 连接件要求/Annectent parts

连接器/linker(有/Yes、没有/No), 型号为/model:

端子/terminal(有/Yes、没有//No), 型号为/model:

