



PRODUCT SPECIFICATION

产品规格书

CUSTOMER 客户名称: G100

PRODUCT NAME 产品名称: AC BRUSHLESS FAN

DIMENSIONS 产品尺寸: 135mm*135mm*38mm

MODEL 产品型号: A5415N-23L-B04

DATE 发布日期: 2018.1.19

Checked 审核	Prepared 制作
Customer Approve 客户核准	

三河市科丰电气有限公司

Tel:0316-3095330 Fax:0316-3095330-8013

Http://www.cnecport.com

1、产品规格要求

PRODUCT SPECIFICATION

NO	检测项目 TEST ITEM	技术参数 SPECIFICATION/CONDITION
1	安规认证 SAFETY AGENCY' S APPROVAL	A5415N-23L-B04
2	尺寸 DIMENSION	135×135×38mm
3	额定电压 RATED VOLTAGE	230 VAC
4	工作电压范围 OPERATING VOLTAGE RANGE	220 VAC ~ 240 VAC
5	启动电压 START-UP VOLTAGE	154 VAC
6	额定电流 RATED CURRENT (A)	50Hz 0.15A (0.165MAX)
		60Hz /
8	额定功率 RATED INPUT POWER (W)	50Hz 23W (25MAX)
		60Hz /
10	风量 AIR FLOW (CFM)	50Hz 113CFM
		60Hz /
12	风压 AIR PRESSURE (mmH ₂ O)	50Hz 6.4(mmH ₂ O)
		60Hz /
14	转速 ROTATIONAL SPEED (R. P. M.)	50Hz 2400±10% (R.P.M.)
		60Hz /
16	噪音 ACOUSTICAL NOISE (dB-A)	50Hz 48dB-A (45dB-A MAX)
		60Hz /
18	绝缘阻抗 INSULATION RESISTANCE	500VDC 100MΩ
19	绝缘耐压 INSULATION & VOLTAGE RESISTANCE	1800VAC (50Hz) 0.5mA 1S
20	平均寿命 LIFE EXPECTANCE	在温度 25℃，相对湿度 15%~65%条件下平均寿命为 50, 000 小时 50,000 HRS AT TEMP. 25℃，15%~65% RH
21	工作温度 OPERATING TEMPERATURE	-20℃~+65℃
22	储存温度 STORAGE TEMPERATURE	-15℃~+70℃
23	重量 WEIGHT	550 g
24	马达保护 MOTOR PROTECTION	阻抗保护 IMPEDANCE PROTECTION
25	绝缘等级 INSULATION TYPE	CLASS B
26	轴承类型 BEARING SYSTEM	滚珠轴承 BALL BEARING
27	外框 FRAME	AL (ADC12)
28	定子与转子 STATOR&ROTOR	矽钢 SILICON STEEL
29	扇叶 FAN BLADE	塑料扇叶 (PBT-PV33%) PLASTICS IMPELLER (PBT-PV33%)

2、产品图纸

PRODUCT DRAWING

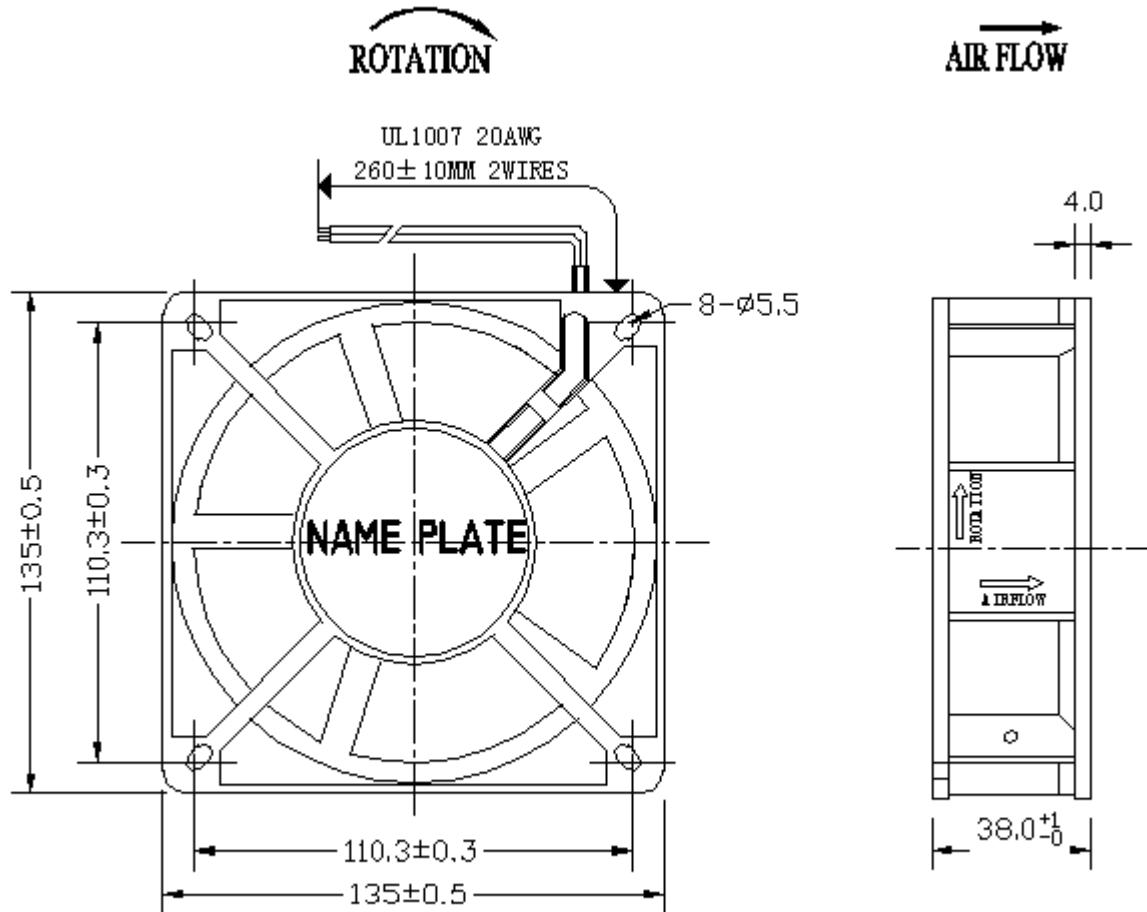

尺寸单位：毫米

DIMENSIONS UNIT:MM

APPROVED DATE	江河 2018-01-19	PART NO.	A5415N-23L-B04
REVIEWED DATE	刘小平 2018-01-19	PAGE	A
PREPARED DATE	王丽娟 2018-01-19	三河市科丰电气有限公司	

3、风扇输出曲线图

Fan output curves of

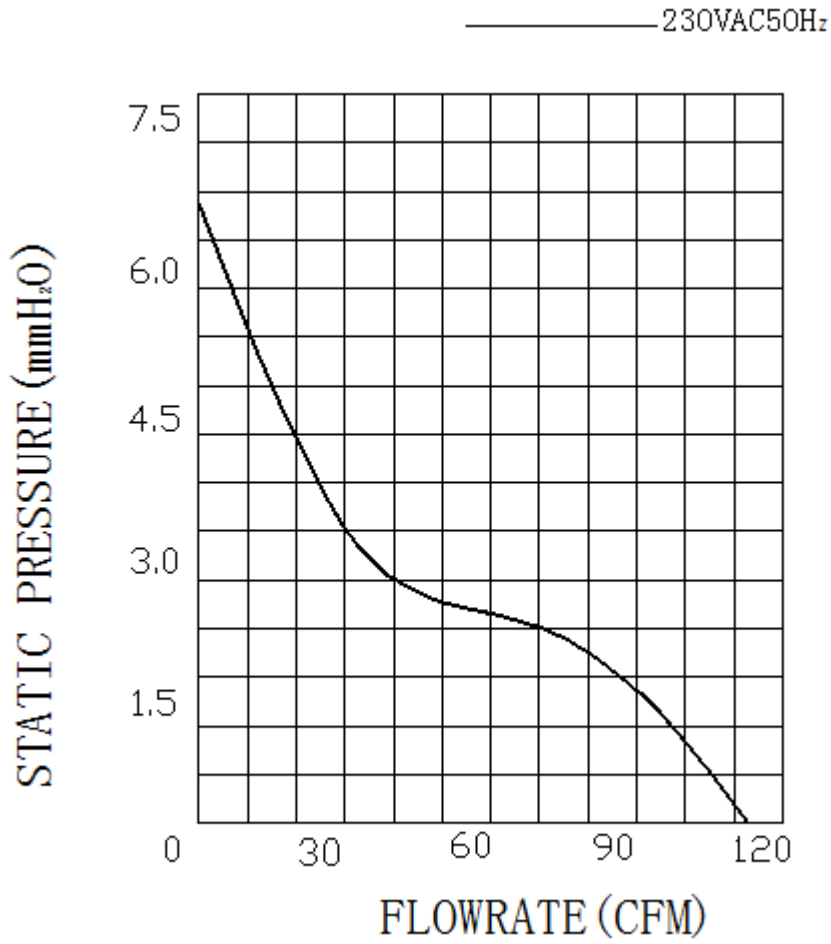

尺寸单位：毫米

DIMENSIONS UNIT:MM

APPROVED DATE	江河 2018-01-19	PART NO.	A5415N-23L-B04
REVIEWED DATE	刘小平 2018-01-19	PAGE	A
PREPARED DATE	王丽娟 2018-01-19	三河市科丰电气有限公司	