



## 1.General Specification

项目 Item	描述 Description	测试条件 Condition
1-1. 外形尺寸 Dimension	225x225x80mm	
1-2. 轴承 Bearing Type	进口双滚珠轴承 Two Ball Bearing	
1-3. 额定电压 Rated Voltage	DC24V	
1-4. 操作电压 Operating Voltage	DC 12V~32V	
1-5. 启动电压 Start-up Voltage	12V	25°C Power ON/OFF
1-6. 额定电流 Rated Current	2.4A	A.At Rated Voltage
1-7. 额定功率 Rated Power	58 W	B.25°C
1-8. 额定转速 Rated Speed	2950rpm/min ± 10%	C.65%RH
1-9. 最大风量 Max. Air Flow	617.62 CFM	A.PQ Measurement Apparatus
	17.5( Min:17.5m <sup>3</sup> /min )	B.Standard: AMCA
1-10. 最大静压 Max.Static Pressure	24.46( Min:24.38)mm-H <sub>2</sub> O	C.Rated Voltage
	0.944(Min:0.944)inch-H <sub>2</sub> O	D.Rated Current
1-11. 噪音 Noise level	64.0(Max:64.0)dBA	A.Rated Voltage
1-12. 寿命预估 Life Expectance	40000hrs at 40°C 相对湿度 15%~95%RH	B.Mute Room
		C.Distance:1M
		D.Background Noise: <18dB
		E.L10 Failure Criteria:
		F.A.Speed:Under15% of original value
1-15.其他特点Other Features	Tachometer Output 测速计输出	●
	Lock Rotor Alarm 锁定报警	●
	LD Rotor Alarm 寿命告警	○
	Auto start 自动重启	●
	Soft Start 软启动	●
	Speed Control Mode 速度控制模式	PWM/0-10V
	Protection level 防护等级	IP20
1-13. 马达极数 Pole	2 Poles	
1-14. 旋转方向 Rating Direction	Clockwise	

## 2. Electrical Specification

项目 Item	条件 Condition
2-1. 锁定扇叶保护功能 Locked Rotor Protection	○ 安规条件 Safety Condition
	● 额定电压下风扇被锁定 1-3 秒时, 自动断电, 并在 2 至 6 秒内自动尝试启动, 锁住扇叶 72 小时无损坏。Auto power off after locked at rated voltage for 1-3sec. And then circuit attempt to restart in 2 to 6 sec, There is no damage after 72hours locking.
2-2. 极性保护 Polarity Protection	● Vcc 与 GND 反接时, 不导通 Open circuit when Vcc&GND are exchanged
	○ Vcc 与 GND 反接时, 5 秒内不烧毁 Circuit won't be burned within 5seconds when Vcc&GND are exchanged
2-3. 绝缘阻抗 Insulation Resistance	At least 10M $\Omega$ at 500 VDC between housing and both lead wires
2-4. 绝缘耐压 Dielectric strength	Withstand 500 VAC 1 minute 1mA between housing and both lead wires

## 3. Specification of Main Material

3-1. 外框材质 Frame	铝制表面抛丸处理 Shot blasting on aluminium surface
3-2. 扇叶材质 Propeller	冷轧板喷塑 Spraying of Cold Rolled Steel Plate
3-3. 绝缘架 Bobbin	PBT UL94V-0
3-4. 导线 Lead wires	Red(+), Black(-), Blue(PWM), Yellow(FG)
3-5. 端子 Connector	端子台 Terminal block
3-6 商标 Lable Marking	型号/Model No: D9032E-05H-B7T/P100 额定电压/Rated Voltage: DC 24V 安规电流/Rated Current: 2.40A

## 4. Environmental Specification

项目 Item	条件 Condition
4-1. 运转温度, 湿度范围 Operating Temp. Humidity Range	Temperature: -20~+60 $^{\circ}$ C
	Humidity :15%~95%RH
4-2. 保存温度, 湿度范围 Storage Temp. Range	Temperature: -20~+85 $^{\circ}$ C
	Humidity :15%~95%RH

### 5. PWM 与转速曲线 (PWM Vs RPM Curve):

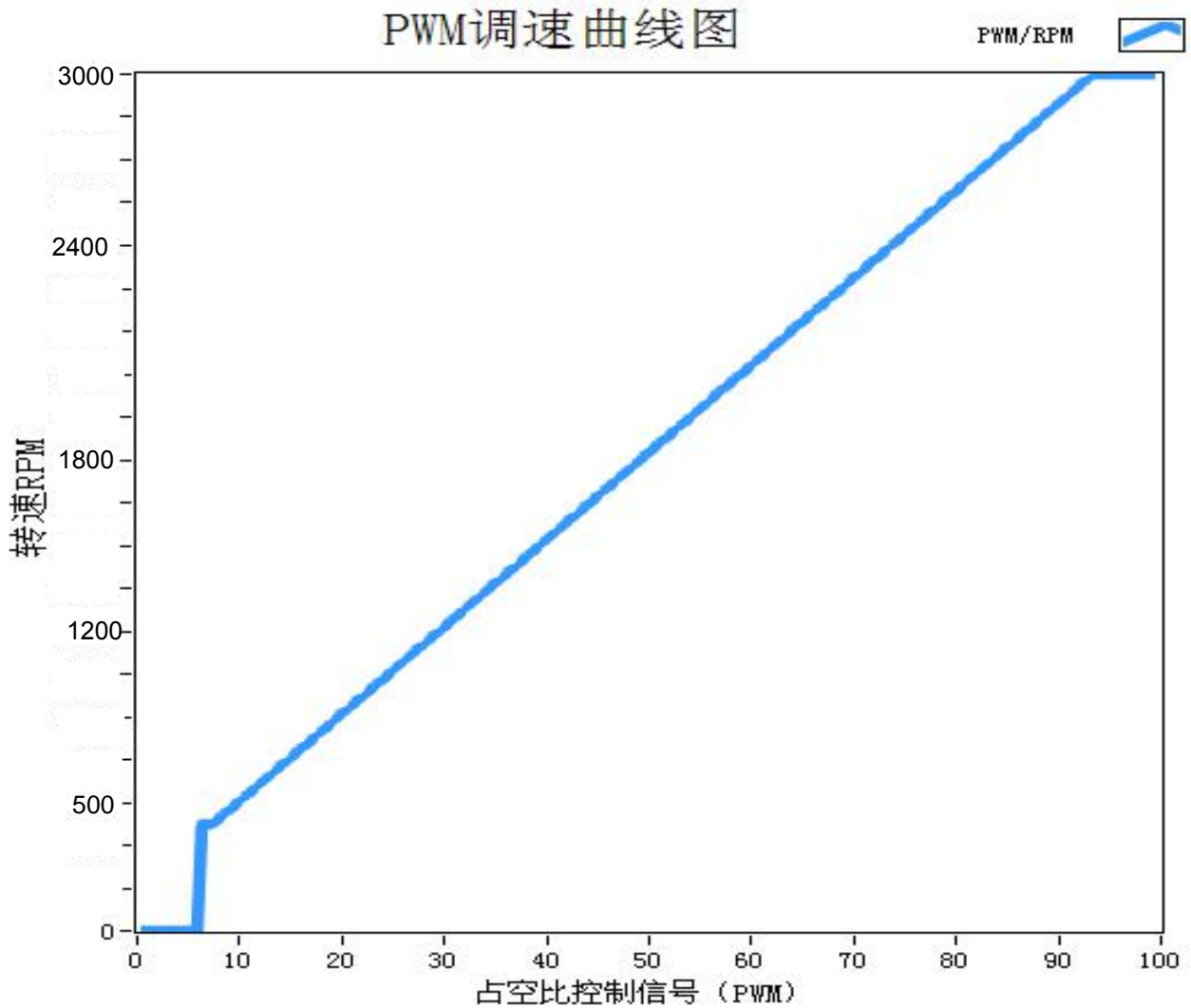

#### 5-1. 曲线说明 (Curves Instructions):

0%-5%不转, 8% 启动 转速=500RPM, 8%-93%转速按斜率上升, 94%-100% 转速=3000RPM

#### 5-2. PWM控制信号 (PWM CONTROLR SIGNAL):

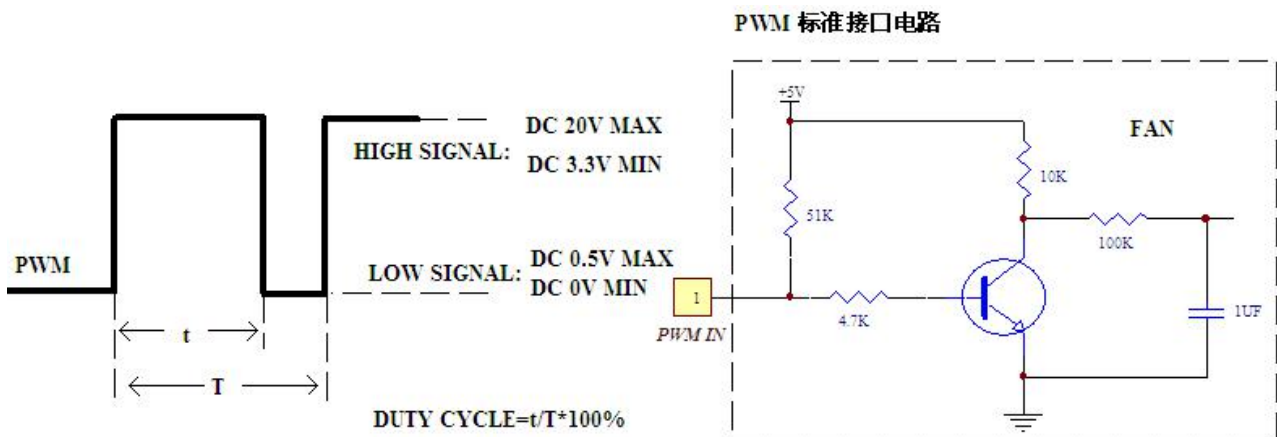

5-3. Input PWM频率范围: 1 KHz-10KHz (The Input PWM frequency range: 1KHz-10KHz )

## 6.频率发生器 (FG) 信号 (FREQUENCY GENERATOR (FG) SIGNAL):

FG: 风扇运转时, 转子的 N,S 极切换会产生高低电平变化, 转速越快, 电平变化也就越快, 从而可以通过变化的频率来侦测风扇的转速。

FG: When fan is running, the switch of rotor N, S can make exchange of high and low level. And speed faster, the frequency of level exchange faster. So we can sense fan's rotation speed via the signal of variational frequency.

### 6-1.FG 输出电路为集电极开路模式 (FG OUTPUT CIRCUIT---OPEN COLLECT MODE)

### 6-2.规格条件 (SPECIFICATION):

VFG= 58Vmax      Rext (min) =VFG/Imax      Imax=5mA      Vce=0.5Vmax

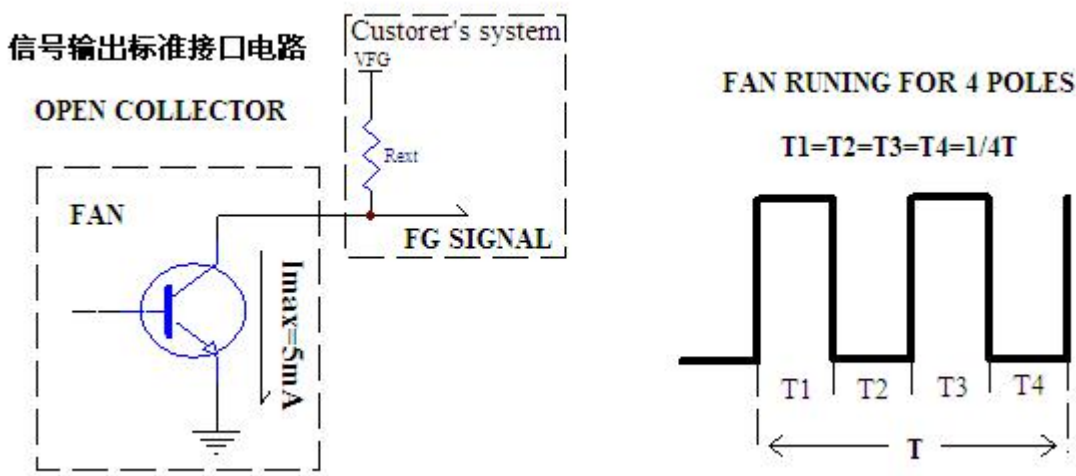

6-3. 每分钟的转速=方波频率\* (120/磁极个数);  $RPM=F* 120/4=30F$

### 6-4.频率发生器波形 (FREQUENCY GENERATOR WAVEFORM):

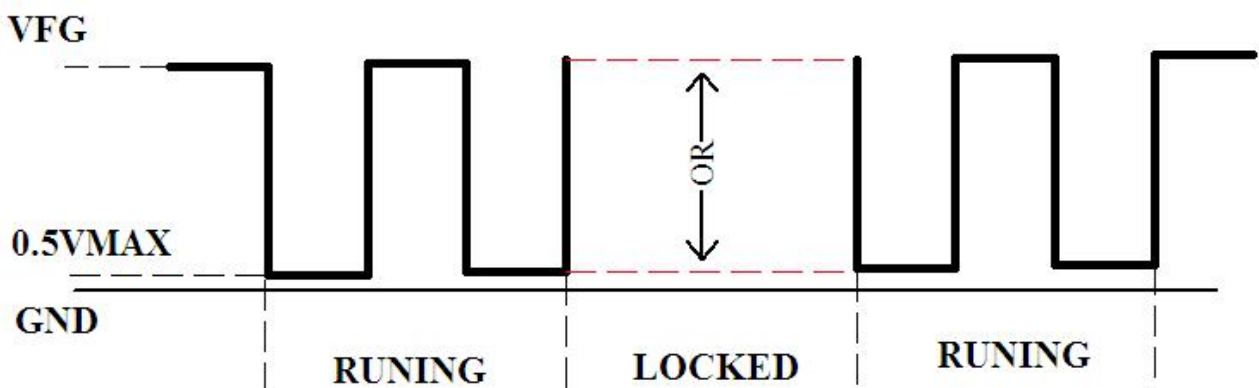

Note:

6-4-1.FG 信号导线不能接触 “+” 和 “-” 引线

FG signal wire can not contact with the "+" and "-" lead wire

6-4-2.当风扇锁住时, FG 信号的输出电压可能是 VFG 或 0V (0.5Vmax)

When Fan is locking, the FG signal output voltage may be VFG or 0V (0.5Vmax)

### 7.P-Q特性曲线测试(P-Q Characteristic curve test):

测试条件及方法 ( Test conditions and methods)	
测试方法 (Testing Method ): 恒定电压测试 Constant Voltage	
大气压力 (Barometric Pressure): 752.4 mmHg	额定电压 At Rated Voltage
相对湿度 (Relative Humidity): 66.825%	测试温度 (Temperature): 25°
测试数据 (test data ):	

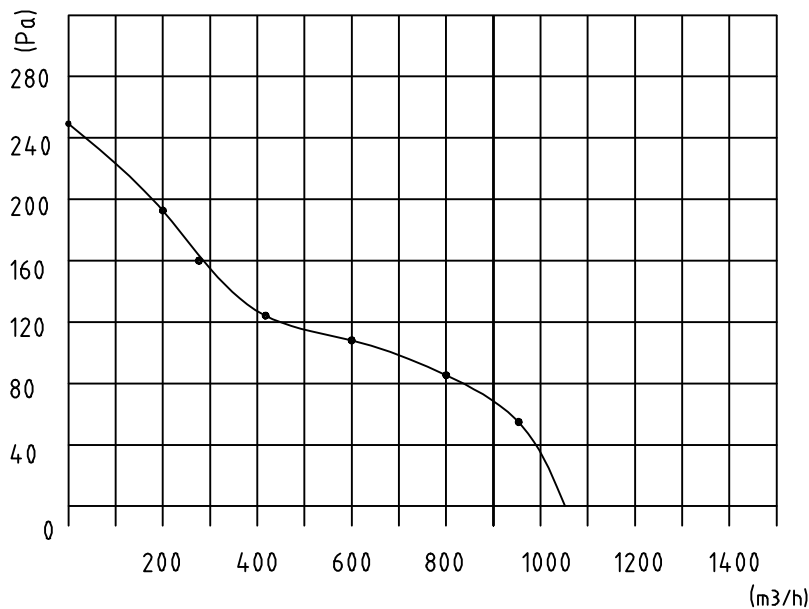

### 8. Noise Test (噪音测试)

测试条件 Test Condition	测试方法 Test Method
1. 温度 Temperature: 26 °C	1. 测试位置 Test Postion: 180°
2. 湿度 Humidity: 62 %RH	2. 测试距离 Test Distance: 1.0M From the fan intake
3. 额定电压 At Rated Voltage: 24VDC	3. 背景噪音 Background Noise: 18.0dB(A)
4. 额定转速 At Rated Speed: 2950RPM	4. 测试依照标准 IS03745执行 This test executes to IS03745 standard
测试设备 Test Equiprment:	
AW6269双通道噪音频谱分析仪	AW6269 double channels noise Spectrum Analyzer
测试结果 Test Result: 噪音: 64.0分贝; Leq: 60.0dB(A)	

# KM92

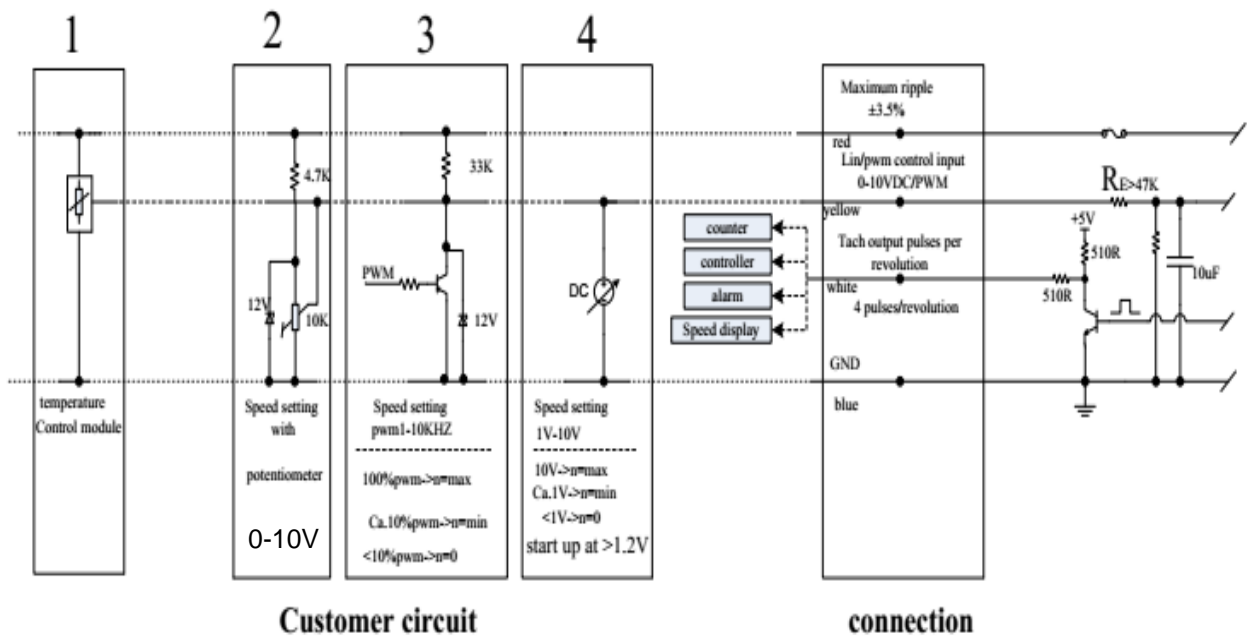

## 主要零件材料 Main parts and materials

项目	材料
硅钢片	W470
定子座	压铸铝合金
漆包线	聚酯漆包线 QZ(G)-2/155
轴	3Cr13
引出线	AVR-90°C, 0.5mm <sup>2</sup>
轴承	NMB/NSK 626ZZ (或同等品质的其他品牌)

8-1. 噪音测试方法示意图 (Schematic diagram of noise test method):



9. 尺寸图 Dimension Drawing

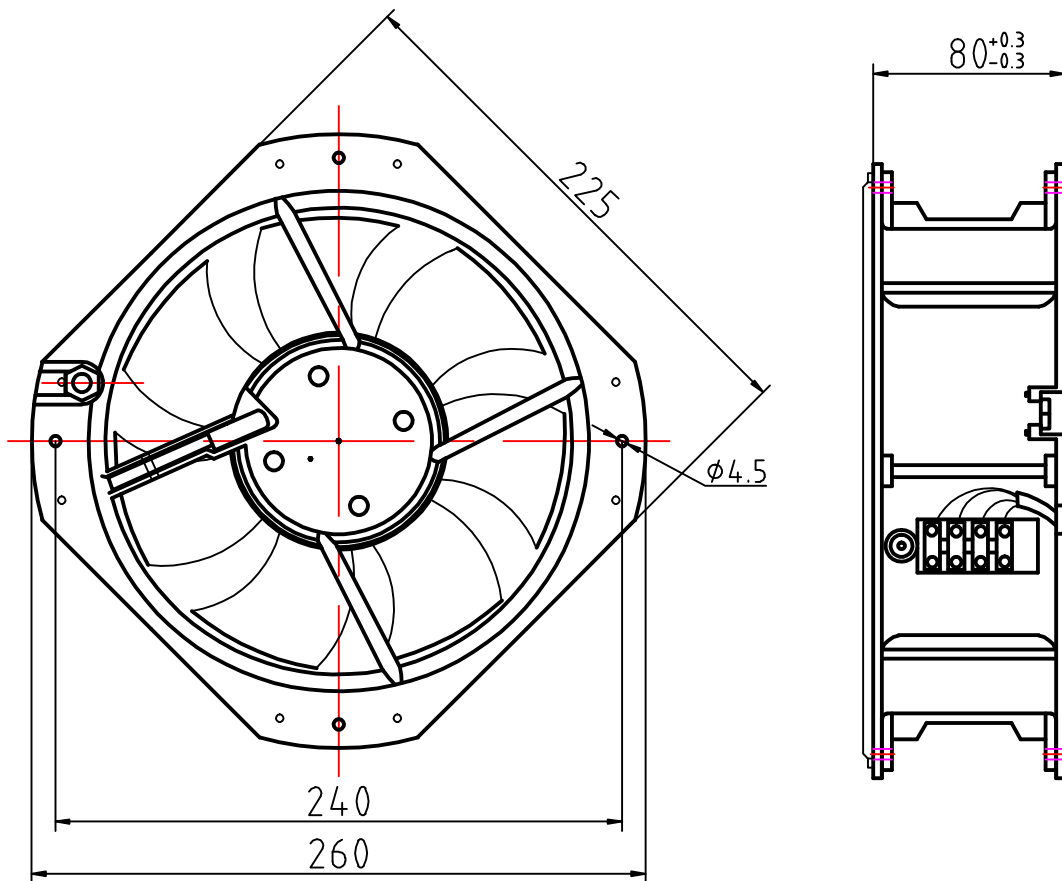



10.Note:

10-1. 使用时请勿超出本规格所规定之极限，否则我们不保证此产品。

We will not guarantee the products if the application of our products are exceeded the limitation which is specified on this specification.

10-2.倘若要变更此份文件的任何规格，请务必事先提出需求。In case of changes of the specification specified on this document.A written notice is requested in advance.

10-3.请勿触压着叶片以及电源线缠绕着风扇或用用拉扯电源线，如此轴心与电源线将会被损毁。

Please do not touch the impeller with the pressure and never bring the fan with lead wire.The bearing and lead wire may be damaged.

10-4. 本产品不保证因粉尘、水滴、小虫进入，而影响寿命与不良品产生。

No guarantee on the products against the safety problem or failure caused by powder dust, drop of water or insect.

10-5.如有任何资料及文件与此份资料不同，将以此份资料为主要参考。

If there is any data or related documentation different from this data sheet.This data sheet is the principle reference.

10-6.请勿在可燃性气体与任何有害环境中使用。

Please do not use the fan in the environment of corrosive gas or liquid or any detrimental gas.

10-7.组装风扇时，请特别注意，因共振或振动产生的噪音。

During the installation of the fan, please pay substantial attention to possible noise caused by resonance vibration and shock.

10-8.当搬运或作业中，风扇如从 60cm 的高度落下，将会对叶片的平衡产生若干影响，特别是滚珠轴承避免掉落。

It is very important to notify that avoid to drop from 60cm height when in any movement or operation,it will impact the balance of blade. Especially ball bearing structure is avoided to drop down.

10-9.锁外壳之螺丝扭力不得超 4Kgf。

The torque of the screw which locked the frame should not exceed 4 Kgf.

10-10.当风扇在运转时，请不要触摸叶片，这样非常危险，容易伤害到您的手指。 Please don't touch the blade when the fan at full speed running , be careful your fingers!