

SC15CLX.2 LBP Compressor R404A/R507 115V 60Hz



General

Code number	104L1853
Approvals	UL984/CSA-C22.2
Compressors on pallet	60

Application

Application	LBP			
Frequency	Hz	50	60	
Evaporating temperature	°F	-	-40 to 20	
Voltage range	V	-	95 - 127	
Max. condensing temperature continuous (short)	°F	-	122 (140)	
Max. winding temperature continuous (short)	°F	-	257 (275)	

Cooling requirements

Frequency	Hz	50			60		
Application		LBP	MBP	HBP	LBP	MBP	HBP
90°F		-	-	-	F ₂	-	-
100°F		-	-	-	F ₂	-	-
110°F		-	-	-	-	-	-

Remarks on application: CSR: 95-127V/60Hz, CSIR: 103-127V/60Hz

Motor

Motor type	CSIR/CSR		
LRA (rated after 4 sec. UL984), HST LST	A	53.0	-
Cut in Current, HST LST	A	53.0	-
Resistance, main start winding (77°F)	Ω	0.9	2.9

Design

Displacement	cu.in	0.93
Oil quantity (type)	fl.oz.	20.3 (polyolester)
Maximum refrigerant charge	oz.	45.5
Free gas volume in compressor	fl.oz.	49.4
Weight without electrical equipment	lbs.	30.9

Dimensions

Height	inch	A	8.62
		B	8.39
		B1	7.60
		B2	4.33
Suction connector	location, I.D. in. angle	C	0.378-0.385 37°
	material comment		Cu-plated steel Al caps
Process connector	location, I.D. in. angle	D	0.252-0.259 37°
	material comment		Cu-plated steel Al caps
Discharge connector	location, I.D. in. angle	E	0.252-0.259 37°
	material comment		Cu-plated steel Al caps
Oil cooler connector	location, I.D. in. angle	F	-
	material comment		-

Remarks:

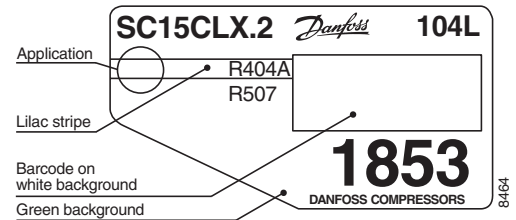

- S = Static cooling normally sufficient
- O = Oil cooling
- F₁ = Fan cooling 1.5 m/s (compressor compartment temperature equal to ambient temperature)
- F₂ = Fan cooling 3.0 m/s necessary
- SG = Suction gas cooling normally sufficient
- = not applicable in this area

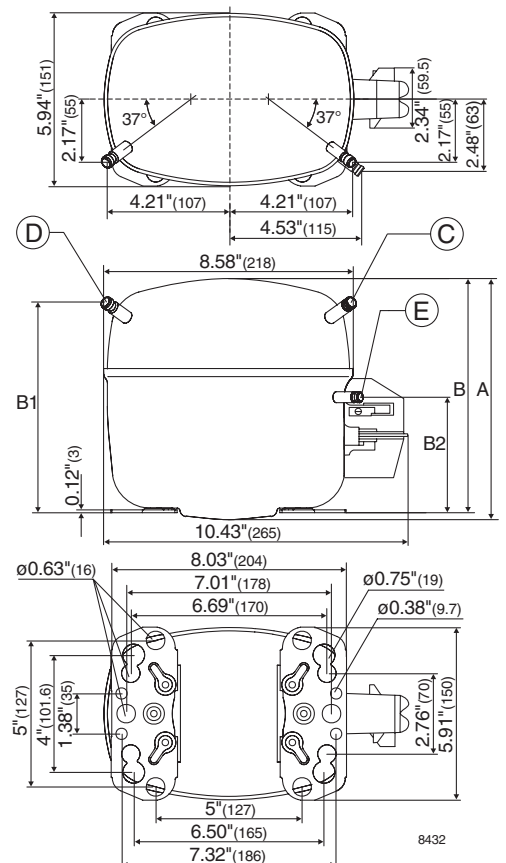

ASHRAE LBP

115V, 60Hz, fan cooling F₂

Evap. temp. in °F	-49	-40	-30	-20	-13	-10	0	10	14	20	30	40	41	45	50	59	68
Capacity in BTU/h		889	1471	2167	2735	3000	3992	5166	5692	6546							
Power cons. in W		424	526	627	698	729	833	941	986	1056							
Current cons. in A		7.42	8.01	8.61	9.04	9.23	9.88	10.54	10.82	11.23							
EER in BTU/Wh		2.10	2.79	3.45	3.92	4.12	4.79	5.49	5.77	6.20							

ASHRAE LBP*

115V, 60Hz, fan cooling F₂

Evap. temp. in °F	-49	-40	-30	-20	-13	-10	0	10	14	20	30	40	41	45	50	59	68
Capacity in BTU/h		1250	1835	2542	3118	3388	4392	5572	6098	6948							
Power cons. in W		439	523	607	668	694	785	883	924	989							
Current cons. in A		7.55	8.04	8.56	8.93	9.09	9.65	10.22	10.46	10.82							
EER in BTU/Wh		2.85	3.51	4.18	4.67	4.88	5.59	6.31	6.60	7.03							

EN 12900 Household (CECOMAF)*

115V, 60Hz, fan cooling F₂

Evap. temp. in °F	-49	-40	-30	-20	-13	-10	0	10	14	20	30	40	41	45	50	59	68
Capacity in BTU/h		1039	1544	2152	2647	2879	3740	4751	5201	5927							
Power cons. in W		438	524	611	672	699	792	891	932	998							
Current cons. in A		7.53	8.04	8.57	8.95	9.12	9.69	10.28	10.52	10.89							
EER in BTU/Wh		2.37	2.95	3.52	3.94	4.12	4.72	5.33	5.58	5.94							

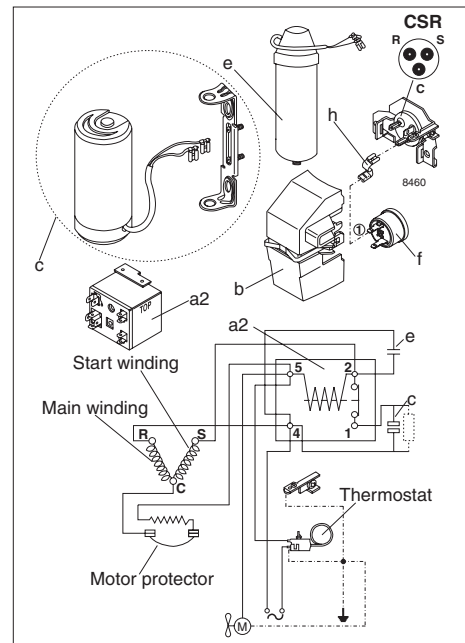
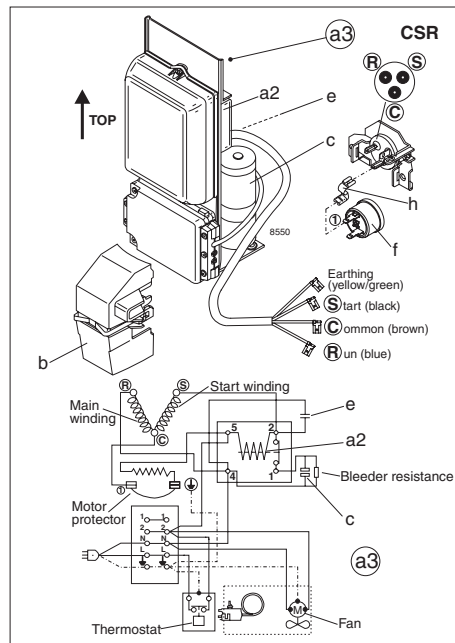
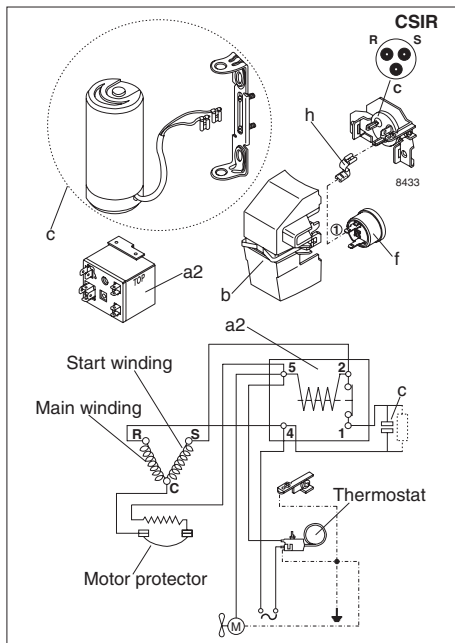

Accessories for	SC15CLX.2	Figure	Code number
Starting device assembly			
CSR	23.6 in. cable length	a3	117-7045
CSIR	23.6 in. cable length		117-7053
Starting device components			
Starting relay	1/4 in. spade connect.	a2	117-7441
Start. capacitor 410 µF	1/4 in. spade connect.	c	117U5043
Run capacitor 23.5 µF	1/4 in. spade connect.	e	117-7114
Cover		b	117U1021 *)
Protector		f	117U3212 *)
Protector holder		h	117U0439 *)
*) Remarks: Cover, protector, protector holder parts of compressor			

Test conditions	ASHRAE LBP	ASHRAE LBP*	EN 12900/CECOMAF*
Condensing temp.	130°F	110°F	113°F
Ambient temperature	90°F	90°F	90°F
Suction gas temp.	90°F	90°F	90°F
Liquid temperature	90°F	90°F	no subcooling

Mounting accessories	Code number
Bolt joint for one comp.	Ø: 5/8 in. 118-1917
Bolt joint in quantities	Ø: 5/8 in. 118-1918
Snap-on in quantities	Ø: 5/8 in. 118-1919

Danfoss can accept no responsibility for possible errors in catalogues, brochures and other printed material. Danfoss reserves the right to alter its products without notice. This also applies to products already on order provided that such alterations can be made without consequential changes being necessary in specifications already agreed. All trademarks in this material are property of the respective companies. Danfoss and the Danfoss logotype are trademarks of Danfoss A/S. All rights reserved.