

Square shaded-pole motors

Standard design

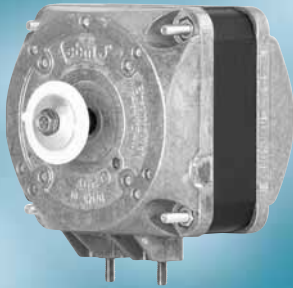

- **Foot mounting:** Track dimension 26 mm (height 51 mm)
- **Type of protection:** IP 42
- **Electrical connection:** Jacketed cable 3 x 0.5 mm² with brass lead tips
- **Product conforming to standard:** CE
- **Approvals:** VDE
- **Curves:** Page 308

Nominal data	Combination: Motor axial impeller	Curve	Nominal voltage	Frequency	Speed/rpm	Power output	Power input	Current draw	Perm. amb. temp.	Mass	Dimensions		
											Type	VAC	Hz
M4Q045-BD01 -01	A	Ⓐ	1~ 230	50	1300	5	29	0.19	-30 to +40	0.9	76	42	15
		Ⓑ	1~ 230	60	1550	5	26	0.17	-30 to +40				
M4Q045-CA01 -01	B	Ⓒ	1~ 230	50	1300	7	31	0.20	-30 to +40	1.1	82	42	15
		Ⓓ	1~ 230	60	1550	8	30	0.20	-30 to +40				
M4Q045-CA03 -51	C	Ⓔ	1~ 230	50	1300	10	36	0.25	-30 to +40	1.2	82	42	15
		Ⓕ	1~ 230	60	1550	9	34	0.22	-30 to +40				
M4Q045-CF01 -01	D	Ⓖ	1~ 230	50	1300	16	60	0.42	-30 to +40	1.3	87	42	15
		Ⓗ	1~ 230	60	1550	16	58	0.36	-30 to +40				
M4Q045-DA01 -01 ⁽¹⁾	E	Ⓙ	1~ 230	50	1300	18	70	0.48	-30 to +40	1.6	93	54	15
		Ⓚ	1~ 230	60	1550	18	62	0.42	-30 to +40				
M4Q045-DA05 -01 ⁽¹⁾	F	Ⓚ	1~ 230	50	1300	23	86	0.62	-30 to +40	1.6	93	54	15
		Ⓛ	1~ 230	60	1550	25	80	0.55	-30 to +40				
M4Q045-EA01 -01 ⁽¹⁾	G	Ⓜ	1~ 230	50	1300	25	90	0.62	-30 to +40	2.0	103	59	16
		Ⓝ	1~ 230	60	1550	26	80	0.55	-30 to +40				
M4Q045-EF01 -01 ⁽¹⁾	H	Ⓞ	1~ 230	50	1300	34	110	0.75	-30 to +40	2.2	125	79	33
		Ⓟ	1~ 230	60	1550	34	100	0.65	-30 to +40				

subject to alterations

(1) Foot mounting possible on A or B side

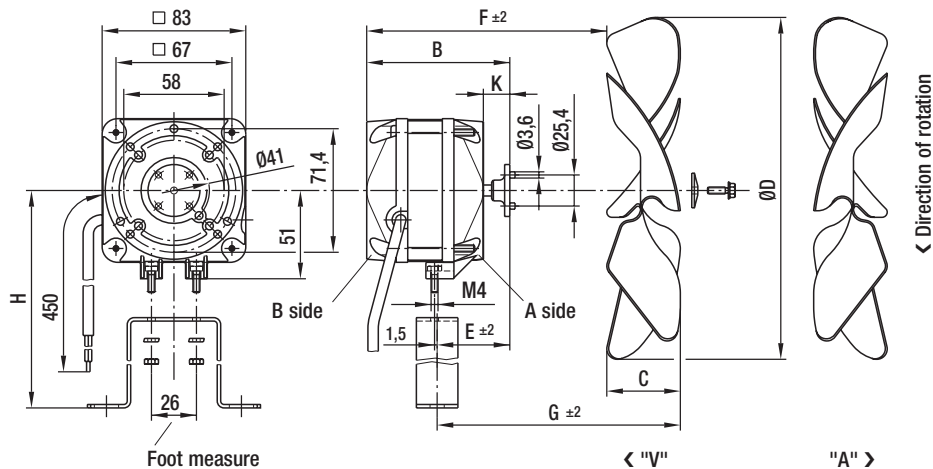

Valid for all designs:

- **Material:** Housing made of die-cast aluminium
Stator pack: Coated in black
- **Direction of air flow:** "V" or "A" (depending on axial impeller used)
- **Direction of rotation:** Counter-clockwise, seen on shaft end
- **Insulation class:** "B"
- **Mounting position:** Any, preferably horizontal
- **Condensate discharges:** None
- **Mode of operation:** Continuous operation (S1)
- **Bearing:** Self-adjusting calotte sleeve bearing (mean service life of 30,000 hours in horizontal installation position)
- **Motor protection:** Impedance protection (combination A-C) or thermal overload protector internally switched (combination D-H)
- **Protection class:** I
- **Mounting:** Guard grille and wall ring are mounted onto the protruding thread ends of the A side. The Q-motor can also be screwed on via the mounting flanges (integrated in the bearing shields).
- **Axial impeller mounting:** Mounted to the motor shaft using a plastic adapter with pulling peg and an M4 screw (combination A-D) or M5 (combination E-H) screw.
- **Power specifications:** At 60 Hz, the blade angle of the axial impellers must be reduced by 6° each.

Axial impellers		Blade angle 22° ± 1°30'				Blade angle 28° ± 1°30'				Blade angle 34° ± 1°30'			
Ø D	H	F	G	C	m³/h ⁽²⁾	F	G	C	m³/h ⁽²⁾	F	G	C	m³/h ⁽²⁾
154	90	61	56	27.5	60	56	59	32.0	100	54	62	37.0	140
172	103	58	57	31.0	120	55	59	36.0	180	53	63	42.0	230
200	123	58	58	32.0	190	55	60	37.5	300	—	—	—	—
200	123	65	58	32.0	190	62	60	37.5	300	59	64	45.0	400
230	123	64	62	35.0	500	—	—	—	—	—	—	—	—
230	123	64	62	35.0	500	60	65	43.0	630	52	68	50.0	820
254	135	64	62	37.0	580	—	—	—	—	—	—	—	—
254	135	70	62	37.0	580	65	66	45.0	840	—	—	—	—
254	135	76	74	37.0	580	72	78	45.0	840	67	80	52.0	1070
300	160	75	79	43.0	1000	—	—	—	—	—	—	—	—
300	160	75	79	43.0	1000	67	81	53.5	1400	—	—	—	—
300	160	86	84	43.0	1000	77	86	53.5	1400	—	—	—	—
300	160	108	104	43.0	1000	104	106	53.5	1400	95	112	61.0	1700

(2) established at counterpressure of 20 Pa