



.EC. MCE400WAN



Dia.400x201.5mm/15.7x7.93inch 1645CFM

Motorized Impeller, Backward curved blades

	额定电压	电压范围	输入功率	额定电流	参考转速	最大风量	最大风压	噪音	PQ Curves
Model No	VAC	VAC	Watt	Amp	RPM	CFM	m3/min	Inch/H2O mm	db(A)
MCE400WAN-11-1**	110	80~135	380	-	1460	1645	46.6	3.1 78.74	72
MCE400WAN-22-1**	220	180~265	380	-	1460	1645	46.6	3.1 78.74	72

- ** = "WB" for wire lead type Ball bearing, or "TB" for terminal type Ball bearing
- 信湾保留修改资料与改良电子&机械设计的权利, 无须告知。资料公差 +/-10%

Motor

马达类别: AC-DC Energy Saving EC Motor

马达防护: Electronically protected

IP 防护: IP55, 56 optional request

Mechanical

外框: Aluminum die casting motor frame

叶轮: Aluminum alloy metal fan blades & flange, motorized backward curved

轴承: Maintenance-free two ball bearings

旋转方向: -

接头: Wire leads

重量: 6100g

Electronical

绝缘强度: 500VAC/min. Max. leakage 500mA

转速控制: Optional: PWM, S/C NTC thermister on request

讯号输出: Optional: R/D alarm output, tachometer output

Environment

使用温度: -20~+65C(non-condensing)

保存温度: -40~+90C

平均预期寿命: L10 formula 90K hours at 35C, 30K hours at 65C

Performance P-Q Curves

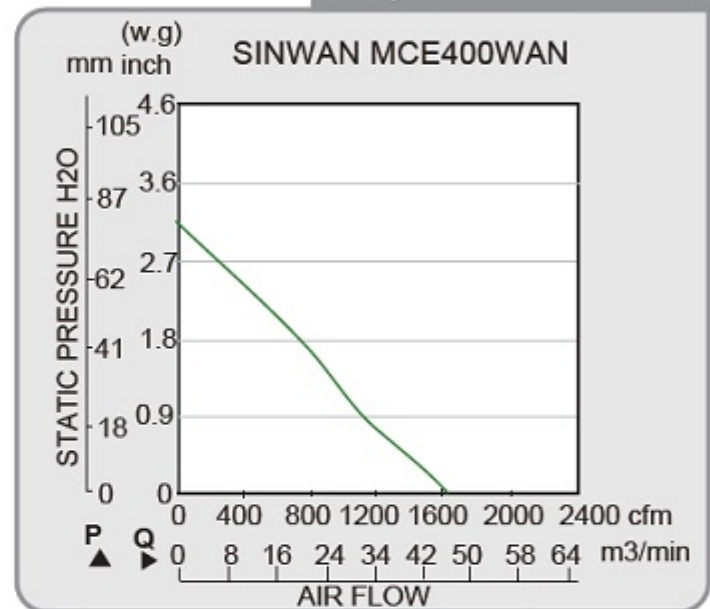

- Nomenclature
- R/D Alarm
- F/G Tach
- S/C Function
- PWM Function

Outline Dimensions

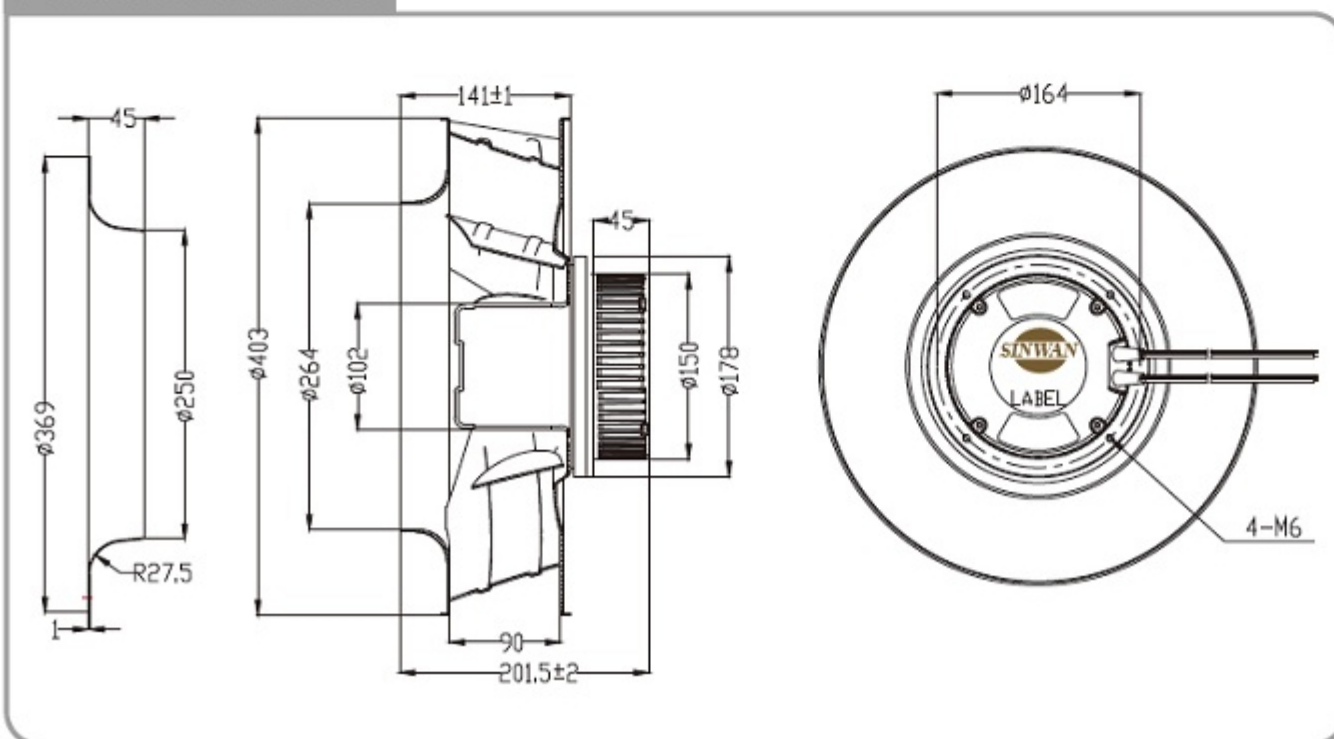

相關產品



Inlet nozzle/Duct ring
DR400SN