

Dia.85x31mm / 3.5inch

35~21 CFM

Plastic Impeller



Model No	额定电压 VAC	电压范围 VAC	频率 Hz	输入功率 Watt	参考转速 RPM	最大风量 CFM	最大风压 m3/min	最大风压 Inch/H2O	最大风压 mm	噪音 db(A)	PQ
SK92EAN-11-1**	115	100~120	50/60	15/13	2500/3000	30/35	0.8/1	0.16/0.20	4.06/5.08	30	
SK92EAN-11-2**	115	100~120	50/60	12/10	2100/2300	25/27	0.7/0.8	0.13/0.14	3.3/3.56	22	
SK92EAN-11-3**	115	100~120	50/60	8/6	1800/1900	21/22	0.6/0.6	0.09/0.10	2.29/2.54	19	
SK92EAN-22-1**	230	200~240	50/60	15/13	2500/3000	30/35	0.8/1	0.16/0.20	4.06/5.08	30	
SK92EAN-22-2**	230	200~240	50/60	12/10	2100/2300	25/27	0.7/0.8	0.13/0.14	3.3/3.56	22	
SK92EAN-22-3**	230	200~240	50/60	8/6	1800/1900	21/22	0.6/0.6	0.09/0.10	2.29/2.54	19	

- The stated airflow, air pressure, noise levels are measured with housing orifice dia.: impeller $\Phi +1 \sim 1.5$ mm, at distance: approx. height of impeller + motor frame. The optimal operating data can only be depended on the installation conditions.
- ** = "WB" for wire lead type Ball bearing, or "TB" for terminal type Ball bearing
- 100, 200, 240V 或特殊电压 12, 24, 28, 38, 42, 48, 380, 440, 480V... 50/60Hz, 任何电压都可订做。
- 双速 高/中 1速/2速, 中/低 2速/3速 可依需求制造。
- 信湾保留修改资料与改良电子&机械设计的权利, 无须告知。资料公差 $\pm 10\%$

Motor

马达类别: Shaded pole, inner rotor, single phase impedance protected motor

马达防护:

IP 防护: IP44

Mechanical

外框: Aluminum diecasting, 7 mounting holes dia.2.3mm or tapped M3

叶轮: Glass fiber reinforced PBT thermoplastic impeller, UL94V-0

轴承: Two precision double sealed ball bearings

旋转方向: CCW seen on rotor

接头: Wire leads connecting AWG22, 300~400mm, stripped ends 3~5mm

重量: 230Gm (0.53 Lb)

Electrical

绝缘强度: Over 1 min. at 1,500 VAC, 50/60 Hz

绝缘电阻: Over 100 Mega Ohm at DC 500V, between leads and frame

讯号输出: -

Environment

使用温度: Ball bearing ambient $-20^{\circ}\text{C} \sim 70^{\circ}\text{C}$

保存温度: $-40^{\circ}\text{C} \sim +100^{\circ}\text{C}$ (at 65%RH)

平均预期寿命: 55K hours at 45°C , 25K hours at 65°C based on life test Formula L10

Performance P-Q Curves



- Nomenclature
- Dual Voltage
- Multiple Speed

Outline Dimensions

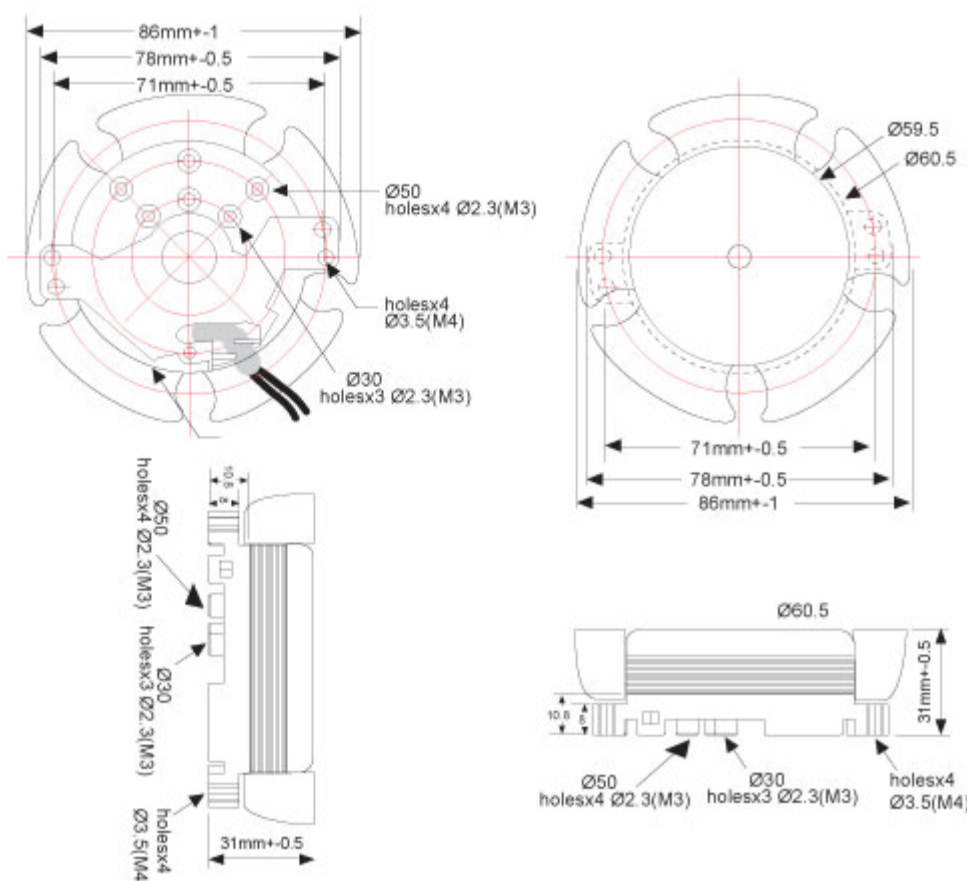

相關產品