

# Dia.160x80mm / 6.5inch

## 410~210 CFM

Metal Impeller



Model No	额定电压 VAC	电压范围 VAC	频率 Hz	输入功率 Watt	参考转速 RPM	最大风量 CFM	最大风压 m3/min	最大风压 Inch/H2O	最大风压 mm	噪音 db(A)	PQ
MK180FAN11-1**(100)	100	100~120	50/60	60/80	2800/3250	340/410	9.6/11.6	0.68/0.75	17.27/19.05	562	2/1
MK180FAN11-1**	115	100~120	50/60	60/80	2800/3250	340/410	9.6/11.6	0.68/0.75	17.27/19.05	562	2/1
MK180FAN11-2**	115	100~120	50/60	55/65	2350/2200	285/275	8.1/7.8	0.58/0.52	14.73/13.21	515	4/3
MK180FAN11-3**	115	100~120	50/60	20/30	1400/1650	165/210	4.7/5.9	0.35/0.38	8.89/9.65	40	6/5
MK180FAN22-1**(200)	200	200~240	50/60	60/80	2800/3250	340/410	9.6/11.6	0.68/0.75	17.27/19.05	562	2/1
MK180FAN22-1**	230	200~240	50/60	60/80	2800/3250	340/410	9.6/11.6	0.68/0.75	17.27/19.05	562	2/1
MK180FAN22-2**	230	200~240	50/60	55/65	2350/2200	285/275	8.1/7.8	0.58/0.52	14.73/13.21	515	4/3
MK180FAN22-3**	230	200~240	50/60	20/30	1400/1650	165/210	4.7/5.9	0.35/0.38	8.89/9.65	40	6/5
MK180FAN22-1**(240)	240	200~240	50/60	60/80	2800/3250	340/410	9.6/11.6	0.68/0.75	17.27/19.05	562	2/1
MK180FAN11/22-1**	115	100~120	50/60	60/80	2800/3250	340/410	9.6/11.6	0.68/0.75	17.27/19.05	562	2/1
dual voltage	230	200~240									
MK180FAN2-1**	12	12~14	50/60	60/80	2800/3250	340/410	9.6/11.6	0.68/0.75	17.27/19.05	562	2/1
MK180FAN4-1**	24	24~28	50/60	60/80	2800/3250	340/410	9.6/11.6	0.68/0.75	17.27/19.05	562	2/1
MK180FAN6-1**	28	28~34	50/60	60/80	2800/3250	340/410	9.6/11.6	0.68/0.75	17.27/19.05	562	2/1
MK180FAN8-1**	48	48~58	50/60	60/80	2800/3250	340/410	9.6/11.6	0.68/0.75	17.27/19.05	562	2/1
MK180FAN44-1**(380)	380	380~440	50/60	60/80	2700/3000	340/378	9.6/10.7	0.68/0.73	17.27/18.54	562	2/1
MK180FAN44-1**	440	380~440(~480)	50/60	60/80	2800/3250	340/410	9.6/11.6	0.68/0.75	17.27/19.05	562	2/1

- The stated airflow, air pressure, noise levels are measured with housing orifice dia.: impeller  $\Phi +1\sim 1.5$ mm, at distance: approx. height of impeller + motor frame. The optimal operating data can only be depended on the installation conditions.
- \*\* = "WB" for wire lead type Ball bearing, or "TB" for terminal type Ball bearing
- 100, 200, 240V 或特殊电压 12, 24, 28, 38, 42, 48, 380, 440, 480V... 50/60Hz, 任何电压都可订做。
- 双速 高/中 1速/2速, 中/低 2速/3速 可依需求制造。
- 信湾保留修改资料与改良电子&机械设计的权利, 无须告知。资料公差  $\pm 10\%$

Motor	
马达类别:	Capacitor induction
马达防护:	Thermal protector
IP 防护:	IP56
Mechanical	
外框:	Aluminum die cast, natural color treatment
叶轮:	Metal 7 blades
轴承:	Two ball bearings
旋转方向:	CCW seen on rotor, air direction
接头:	Wire leads
重量:	1,100Gm(2.4Lb)
Electrical	
绝缘强度:	Over 1 min. at 1,500 VAC, 0.5mA, 50/60 Hz
绝缘电阻:	Over 100 M $\Omega$ at DC 500V
讯号输出:	Optional:R/D alarm output, F/G tachometer output
Environment	
使用温度:	Ambient non-condensing -30~+80C
保存温度:	-40C~+100C (at 65%RH)
平均预期寿命:	50K hours at 55C

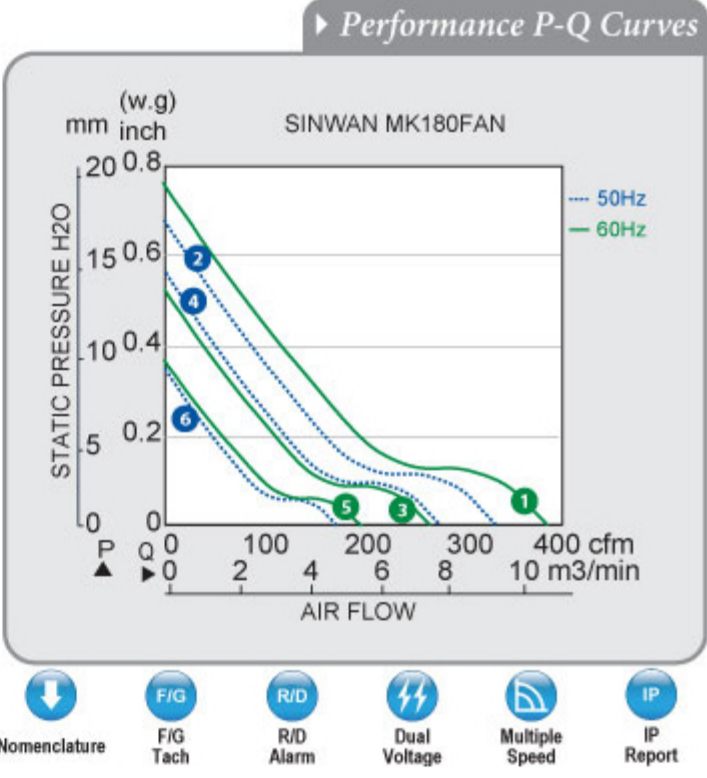

### Outline Dimensions

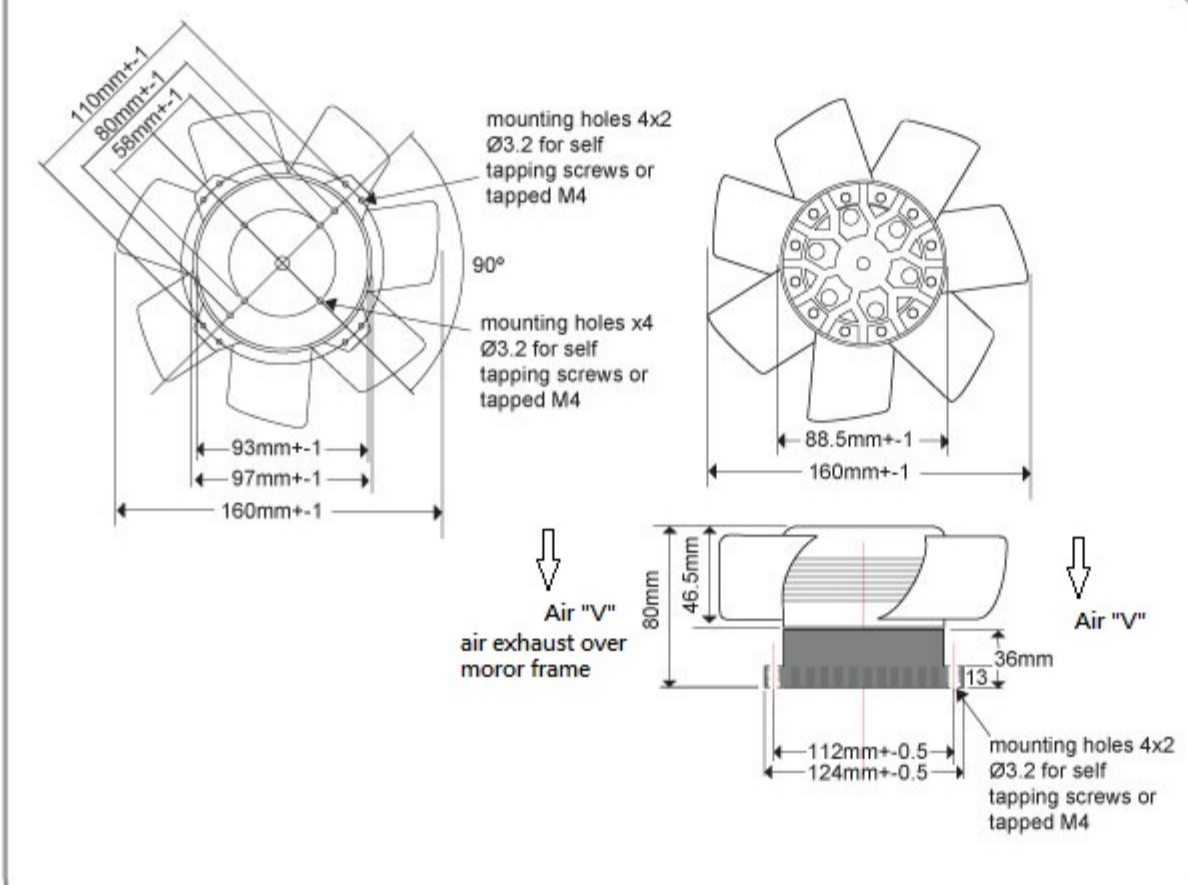

相關產品

Motor  
Sinwan Motor MEA180GAN