



225x225x80mm/8.86x3.15 inch 692 CFM

Sinwan Plastic Impeller, Inner Rotor Tubeaxial Fan

	额定电压	电压范围	频率	输入功率	参考转速	最大风量	最大风压	噪音	PQ
Model No	VAC	VAC	Hz	Watt	RPM	CFM	m3/min Inch/H2O mm	db(A)	
S225AP-11-1**	115	100~120	50/60	60/70 (~90)	2780/3150	610/692	17.3/19.6 0.87/0.76 22.1/19.3	71	2/1
S225AP-11-2**	115	100~120	50/60	40/50	2400/2200	527/483	14.9/13.7 0.71/0.52 18.03/13.21	58	4/3
S225AP-11-3**	115	100~120	50/60	25/38	1500/1650	330/362	9.3/10.3 0.51/0.43 12.95/10.92	49	6/5
S225AP-11-1/2** dual speed	115	100~120	50/60	-1 60/70 -2 40/50	2780/3150 2200/2300	610/692 483/505	17.3/19.6 13.7/14.3 0.87/0.76 0.71/0.52 22.1/19.3 18.03/13.21	71	4/3
S225AP-22-1**	230	200~240	50/60	60/70 (~90)	2780/3150	610/692	17.3/19.6 0.87/0.76 22.1/19.3	71	2/1
S225AP-22-2**	230	200~240	50/60	40/50	2400/2200	527/483	14.9/13.7 0.71/0.52 18.03/13.21	58	4/3
S225AP-22-3**	230	200~240	50/60	25/38	1500/1650	330/362	9.3/10.3 0.51/0.43 12.95/10.92	49	6/5
S225AP-22-1/2** dual speed	230	200~240	50/60	60/70 40/50	2780/3150 2200/2300	610/692 483/505	17.3/19.6 13.7/14.3 0.87/0.76 0.71/0.52 22.1/19.3 18.03/13.21	71	4/3
S225AP-11/22-1** dual voltage	115 or 230	100~120 200~240	50/60	60/70	2780/3150	610/692	17.3/19.6 0.87/0.76 22.1/19.3	71	2/1
S225AP-38-1**	380	380~420	50/60	60/70	2780/3150	610/692	17.3/19.6 0.87/0.76 22.1/19.3	71	2/1
S225AP-44-1**	440	440~480	50/60	60/70	2780/3150	610/692	17.3/19.6 0.87/0.76 22.1/19.3	71	2/1

- ** = "WB" for wire lead type Ball bearing, "TB" for push-in terminal type, or Terminal block type with Ball bearing
- 100, 200, 240V 或特殊电压 12, 24, 28, 38, 42, 48, 380, 440, 480V... 50/60Hz, 任何电压都可订做。
- 双速 高/中 1速/2速, 中/低 2速/3速 可依需求制造。
- 信湾保留修改资料与改良电子&机械设计的权利, 无须告知。资料公差 +/-10%

Motor

马达类别: Capacitor induction, inner rotor, 1 phase, 2 or 4 pole

马达防护: Thermal protector, auto cut-off, auto reset

IP 防护: IP ratings optional on request

Mechanical

外框: Aluminum die cast, black coating treatment

叶轮: 5 blades, glass fiber reinforced plastic, rated UL94V-0

轴承: Two ball bearings

旋转方向: CCW seen on rotor, air direction exhaust over struts

接头: Wire leads, or terminal flat pins; terminal block optional

重量: 2400 g (5.3 Lbs)

Electrical

绝缘强度: Over 1 min. at 1,500 VAC, 0.5mA, 50/60 Hz

绝缘电阻: Over 100 MΩ at DC 500V

讯号输出: Optional: Motor slow down alarm R/D, tachometer F/G

Environment

使用温度: Ambient non-condensing -20~+70C

保存温度: -40C~+100C (at 65%RH)

平均预期寿命: L10 Formula 80K hours at 35C, 35K hours at 60C

Performance P-Q Curves

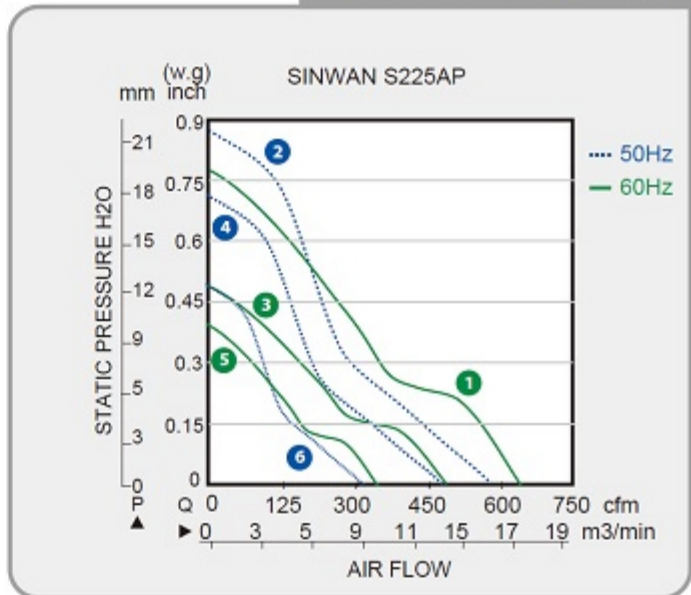

- Nomenclature
- F/G Tach
- R/D Alarm
- Dual Voltage
- Multiple Speed

Outline Dimensions

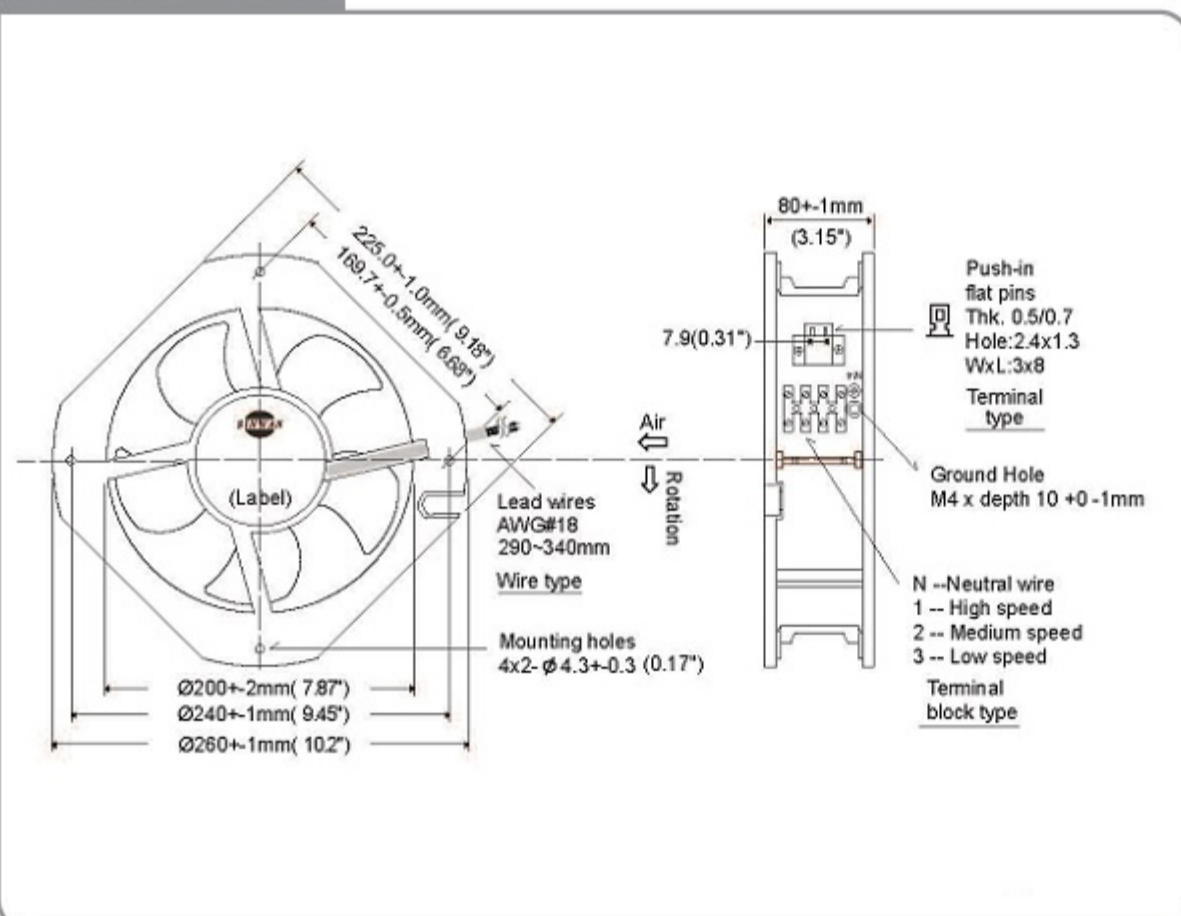

相关产品



Metal Fan Guard

G225-5DF, G225-13U