

ebm-papst Mulfingen GmbH & Co. KG  
 Bachmühle 2  
 D-74673 Mulfingen  
 Phone +49 (0) 7938 81-0  
 Fax +49 (0) 7938 81-110  
 info1@de.ebmpapst.com  
 www.ebmpapst.com

## CONTENTS

|   |          |
|---|----------|
| <b>1. SAFETY REGULATIONS AND INFORMATION</b>                      | <b>1</b> |
| 1.1 Hazard levels for warnings                                    | 1        |
| 1.2 Staff qualifications  | 1        |
| 1.3 Basic safety rules  | 1        |
| 1.4 Voltage   | 1        |
| 1.5 Safety and protective features                                | 2        |
| 1.6 Electromagnetic radiation                                     | 2        |
| 1.7 Mechanical movement   | 2        |
| 1.8 Emissions   | 2        |
| 1.9 Hot surface   | 2        |
| 1.10 Transport  | 2        |
| 1.11 Storage  | 2        |
| <b>2. INTENDED USE</b>  | <b>3</b> |
| <b>3. TECHNICAL DATA</b>  | <b>4</b> |
| 3.1 Product drawing   | 4        |
| 3.2 Nominal data  | 5        |
| 3.3 Technical description   | 5        |
| 3.4 Mounting data   | 5        |
| 3.5 Transport and storage conditions                              | 5        |
| 3.6 Electromagnetic compatibility                                 | 5        |
| <b>4. CONNECTION AND STARTUP</b>                                  | <b>6</b> |
| 4.1 Mechanical connection   | 6        |
| 4.2 Electrical connection   | 6        |
| 4.3 Connection via terminal strip                                 | 6        |
| 4.4 Connection diagram  | 7        |
| 4.5 Checking connections  | 8        |
| 4.6 Switching on the device                                       | 8        |
| 4.7 Switching off the device                                      | 8        |
| <b>5. MAINTENANCE, MALFUNCTIONS, POSSIBLE CAUSES AND REMEDIES</b> | <b>8</b> |
| 5.1 Cleaning  | 9        |
| 5.2 Safety inspection   | 9        |
| 5.3 Disposal  | 9        |

## 1. SAFETY REGULATIONS AND INFORMATION

Read these operating instructions carefully before starting work on the device. Observe the following warnings to prevent malfunctions or danger to persons.

These operating instructions are to be regarded as part of the device. The device is only to be sold or passed on together with the operating instructions.

These operating instructions may be duplicated and distributed to inform about potential dangers and their prevention.

### 1.1 Hazard levels for warnings

These operating instructions use the following hazard levels to indicate potentially hazardous situations and important safety regulations:



#### DANGER

Indicates an imminently hazardous situation which will result in death or serious injury if the specified actions are not taken. Compliance with the instructions is imperative.

#### WARNING

Indicates a potentially hazardous situation which can result in death or serious injury if the specified actions are not taken. Exercise extreme caution while working.

#### CAUTION

Indicates a potentially hazardous situation which can result in minor or moderate injury or damage to property if the specified actions are not taken.

#### NOTE

A potentially harmful situation can occur and, if not avoided, can lead to property damage.

### 1.2 Staff qualifications

The device may only be transported, unpacked, installed, operated, maintained and otherwise used by suitably qualified, trained and authorized technical staff.

Only authorized specialists are permitted to install the device, to carry out a test run and to perform work on the electrical installation.

### 1.3 Basic safety rules

The safety hazards associated with the device must be assessed again following installation in the final product.

Note the following when working on the device:

- ⇒ Do not perform any modifications, additions or conversions on the device without the approval of ebm-papst.

### 1.4 Voltage

- ⇒ Check the device's electrical equipment at regular intervals; see Chapter 5.2 Safety inspection.
- ⇒ Replace loose connections and defective cables immediately.

#### WARNING

**Live terminals and connections even with device switched off**  
 Electric shock

→ Wait five minutes after disconnecting the voltage at all poles before opening the device.

#### CAUTION

**If control voltage or a stored speed set value is applied, the motor will restart automatically, e.g. after a power failure.**

Risk of injury

- Keep out of the device danger zone.
- When working on the device, switch off the line voltage and ensure that it cannot be switched back on.
- After working on the device, remove any tools or other objects from the device.

### 1.5 Safety and protective features



#### **DANGER**

#### **Protective device missing and protective device not functioning**

Without a protective device there is a risk of serious injury, for instance if the hands reach or are sucked into the device during operation.

- Operate the device only with a fixed protective device and guard grille. # The fixed protective device must be able to withstand the kinetic energy of a fan blade that becomes detached at maximum speed. There must not be any gaps which it is possible to reach into with the fingers, for example.
- The device is a built-in component. As the operator, you are responsible for ensuring that the device is secured adequately.
- Stop the device immediately if you notice a missing or ineffective protective device.

### 1.6 Electromagnetic radiation

Interference from electromagnetic radiation is possible, e.g. in conjunction with open- and closed-loop control devices.

If impermissible radiation levels occur following installation, appropriate shielding measures have to be taken by the user.

#### **NOTE**

#### **Electrical or electromagnetic interference after installing the device in customer equipment.**

- Verify that the entire setup is EMC-compliant.

### 1.7 Mechanical movement



#### **DANGER**

#### **Rotating device**

Risk of injury to body parts coming into contact with the rotor or the impeller.

- Secure the device against accidental contact.
- Before working on the system/machine, wait until all parts have come to a standstill.

#### **WARNING**

#### **Rotating device**

Long hair and dangling items of clothing, jewelry and the like can become entangled and be pulled into the device. Injuries can result.

- Do not wear any loose-fitting or dangling clothing or jewelry while working on rotating parts. #Protect long hair with a cap.

### 1.8 Emissions

#### **WARNING**

#### **Depending on the installation and operating conditions, the sound pressure level may exceed 70 dB(A).**

Risk of noise-induced hearing loss

- Take appropriate technical safety measures.
- Protect operating personnel with appropriate safety equipment such as hearing protection.
- Also observe the requirements of local agencies.

### 1.9 Hot surface



#### **CAUTION**

#### **High temperature on electronics housing**

Risk of burns

- Ensure sufficient protection against accidental contact.

### 1.10 Transport

#### **NOTE**

#### **Transporting the device**

- Transport the device in its original packaging only.
- Secure the device so it cannot slip, e.g. by using a lashing strip.

### 1.11 Storage

- ⇒ Store the device, partially or fully assembled, in a dry and weatherproof manner in the original packaging in a clean environment.
- ⇒ Protect the device against environmental effects and dirt until final installation.
- ⇒ We recommend storing the device for no longer than one year in order to guarantee trouble-free operation and the longest possible service life.
- ⇒ Even devices explicitly intended for outdoor use are to be stored as described prior to commissioning.
- ⇒ Maintain the storage temperature, see Chapter 3.5 Transport and storage conditions.

## 2. INTENDED USE

The device is exclusively designed as a built-in device for conveying air according to its technical data.

Any other usage above and beyond this does not conform with the intended purpose and constitutes misuse of the device.

Customer equipment must be capable of withstanding the mechanical and thermal stresses that can arise from this product. This applies for the entire service life of the equipment in which this product is installed.

### Intended use also includes

- Using the device in DC grids only.
- conveying air at an ambient air pressure between 750 mbar and 1050 mbar.
- Using the device within the permitted ambient temperature range; see Chapter 3.5 Transport and storage conditions and Chapter 3.2 Nominal data.
- Operating the device with all protective devices.
- Following the operating instructions.

### Improper use

In particular, operating the device in the following ways is prohibited and could be hazardous:

- Operating the device in an unbalanced state, e.g. due to dirt deposits or ice formation.
- Conveying air that contains abrasive particles.
- Conveying highly corrosive air, e.g. salt spray. Exception: devices designed for salt spray and correspondingly protected.
- Conveying air with high dust content, e.g. suctioning off sawdust.
- Operating the device close to flammable materials or components.
- Operating the device in an explosive atmosphere.
- Using the device as a safety component or to perform safety-related functions.
- Operation with completely or partially disassembled or manipulated protective devices.
- In addition, all applications not listed among the intended uses.

## 3. TECHNICAL DATA

## 3.1 Product drawing

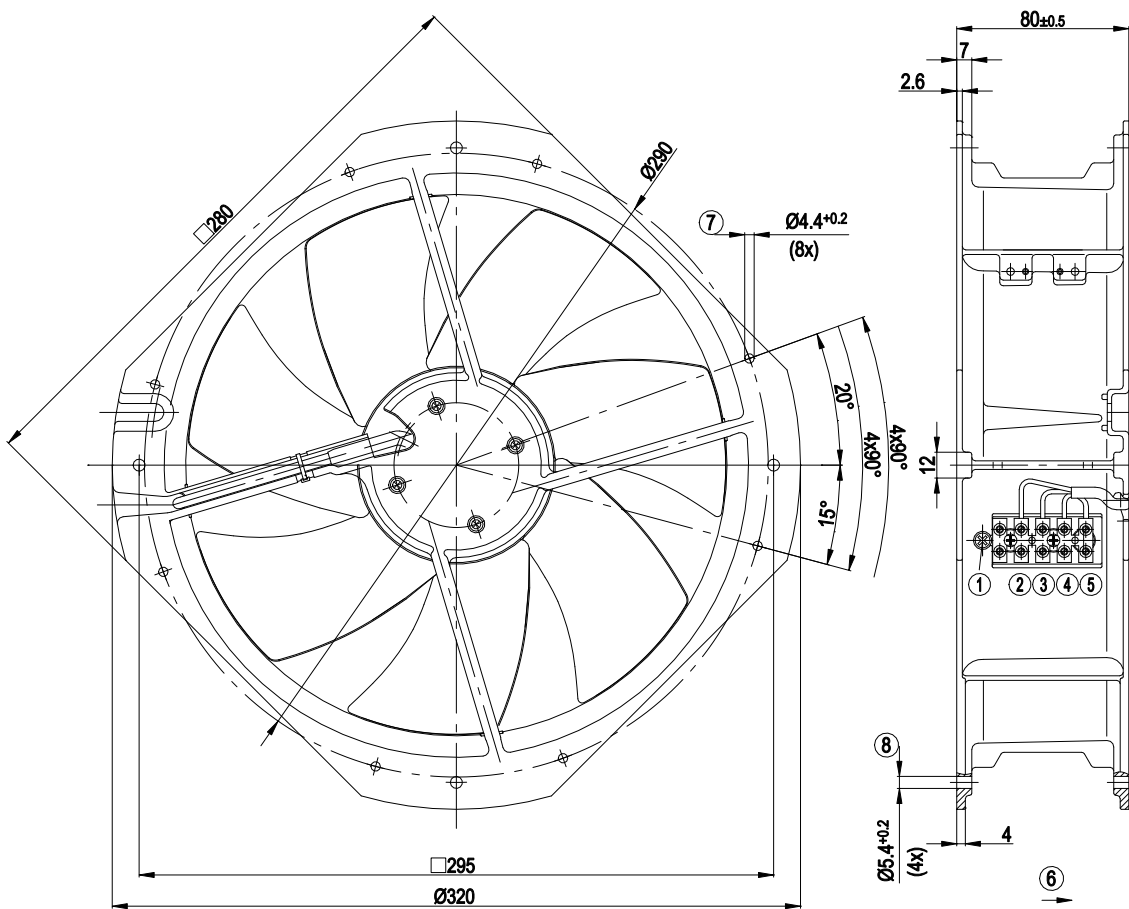

All dimensions in mm.

|   |                            |
|---|----------------------------|
| 1 | Protective earth           |
| 2 | Control input yellow       |
| 3 | Speed monitoring white     |
| 4 | (-) blue                   |
| 5 | (+) red                    |
| 6 | Direction of air flow "V"  |
| 7 | For self-tapping M5 screws |
| 8 | For self-tapping M6 screws |

## 3.2 Nominal data

|                               |           |
|-------------------------------|-----------|
| Motor                         | M1G074-BF |
| Nominal voltage / VDC         | 24        |
| Nominal voltage range / VDC   | 16 .. 28  |
| Method of obtaining data      | fa        |
| Speed / min <sup>-1</sup>     | 2750      |
| Power consumption / W         | 105       |
| Current draw / A              | 5.0       |
| Max. back pressure / Pa       | 140       |
| Min. ambient temperature / °C | -25       |
| Max. ambient temperature / °C | 60        |

ml = Max. load · me = Max. efficiency · fa = Free air  
 cs = Customer specification · ce = Customer equipment

Subject to change

## 3.3 Technical description

|   |   |
|---|---|
| Weight  | 2.4 kg  |
| Fan size  | 250 mm  |
| Rotor surface                                     | Painted black   |
| Blade material                                    | Sheet steel, painted black  |
| Fan housing material                              | Die-cast aluminum   |
| Number of blades                                  | 7   |
| Airflow direction                                 | "V"   |
| Direction of rotation                             | Counterclockwise, viewed toward rotor   |
| Degree of protection                              | IP42  |
| Insulation class                                  | "B"   |
| Moisture (F) / Environmental (H) protection class | F0  |
| Installation position                             | Any   |
| Condensation drainage holes                       | None  |
| Mode  | S1  |
| Motor bearing                                     | Ball bearing  |
| Technical features                                | - Control input 0-10 VDC / PWM<br>- Tach output<br>- Motor current limitation<br>- Soft start |
| Electrical hookup                                 | Via terminal strip  |
| Motor protection                                  | Reverse polarity and locked-rotor protection  |
| Conformity with standards                         | EN 60950-1  |
| Approval  | CSA C22.2 No. 77; EAC; UL 1004-1  |



With regard to cyclic speed loads, note that the rotating parts of the device are designed for a maximum of one million load cycles. If you have special questions, consult ebm-papst for support.

## 3.4 Mounting data

For screw clearance, see Chapter 3.1 Product drawing

⇒ Secure the screws against unintentional loosening (e.g. use self-locking screws).

|                          |     |
|--------------------------|-----|
| Strength class of screws | 8.8 |
|--------------------------|-----|

Any further mounting data required can be taken from the product drawing.

## 3.5 Transport and storage conditions

⇒ Use the device in accordance with its degree of protection.

|  |        |
|--|--------|
| Max. permitted ambient temp. for motor (transport/storage) | +80 °C |
| Min. permitted ambient temp. for motor (transport/storage) | -40 °C |

## 3.6 Electromagnetic compatibility

|                              |  |
|------------------------------|--|
| EMC immunity to interference | According to EN 61000-6-2 (industrial environment)     |
| EMC interference emission    | According to EN 55022 (Class B, household environment) |

## 4. CONNECTION AND STARTUP

### 4.1 Mechanical connection



#### CAUTION

**Cutting and crushing hazard when removing device from packaging**

Blades can bend



→ Carefully remove the device from its packaging, by the fan housing. Strictly avoid shocks.

→ Wear safety shoes and cut-resistant safety gloves.

⇒ Check the device for transport damage. Damaged devices are not to be installed.

⇒ Install the undamaged device in accordance with your application.



#### CAUTION

**Possible damage to the device**

If the device slips during installation, serious damage can result.

→ Ensure that the device is securely positioned at its place of installation until all fastening screws have been tightened.

### 4.2 Electrical connection

#### CAUTION

##### Voltage

The fan is a built-in component and has no disconnecting switch.

→ Only connect the fan to circuits that can be switched off with an all-pole disconnection switch.

→ When working on the fan, secure the system/machine in which the fan is installed so as to prevent it from being switched back on.

#### NOTE

##### Water ingress into wires or cables

Water ingress at the customer end of the cable can damage the device.

→ Make sure the end of the cable is connected in a dry environment.



Operate the device with a safely isolated power supply.

#### 4.2.1 Requirements

⇒ Check whether the data on the nameplate match the connection data.

⇒ Before connecting the device, make sure the power supply matches the device voltage.

⇒ Only use cables designed for the current level indicated on the nameplate.

For determining the cross-section, note the sizing criteria according to EN 61800-5-1. The protective earth must have a cross-section equal to or greater than that of the phase conductor.

We recommend the use of 105 °C cables. Ensure that the minimum cable cross-section is at least AWG 26 / 0.13 mm<sup>2</sup>.

#### 4.2.2 Reactive currents



Because of the EMC filter integrated for compliance with EMC limits (interference emission and immunity to interference), reactive currents can be measured in the supply line even when the motor is at a standstill and the line voltage is switched on.

### 4.3 Connection via terminal strip

#### 4.3.1 Connecting wires to terminals

#### WARNING

**Live terminals and connections even with device switched off**

Electric shock

→ Wait five minutes after disconnecting the voltage at all poles before opening the device.

⇒ Insert the wires into the terminals, see Chapter 4.4 Connection diagram.

## 4.4 Connection diagram

### Customer circuit

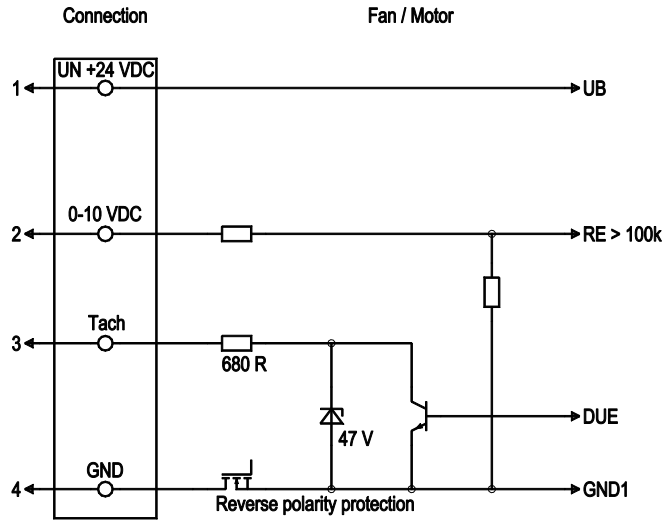
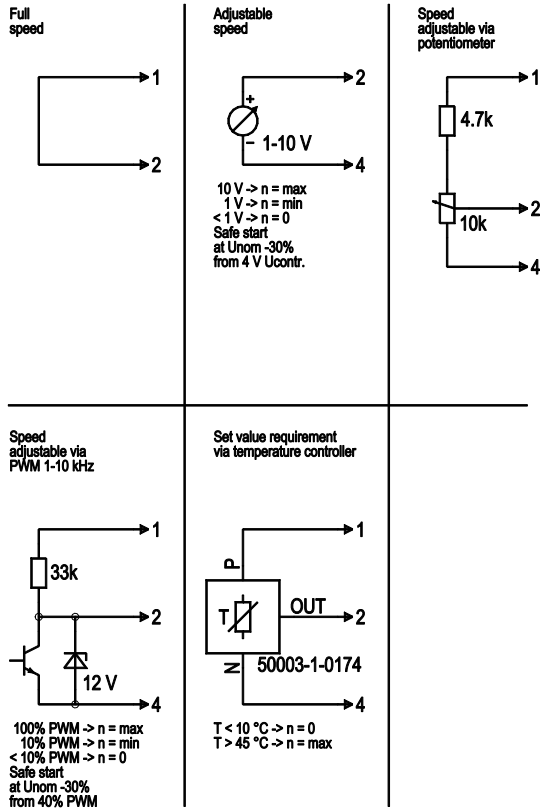

Drawing preliminary!

| No. | Conn. | Designation | Color  | Function/assignment                                     |
|-----|-------|-------------|--------|---|
| 1   | 1     | Un +24 VDC  | red    | Power supply 24 VDC, maximum ripple 3.5 %               |
| 1   | 2     | 0-10 VDC    | yellow | Control input Re > 100k                                 |
| 1   | 3     | Tach        | white  | Tach output, 3 pulses per revolution, Isink max = 10 mA |
| 1   | 4     | GND         | blue   | Reference ground  |

#### 4.5 Checking connections

- ⇒ Ensure isolation from supply (all phases).
- ⇒ Make sure a restart is impossible
- ⇒ Check the cables for proper fit.

#### 4.6 Switching on the device

The device may only be switched on if it has been installed properly and in accordance with its intended use, including the required safety mechanisms and professional electrical hookup. This also applies for devices which have already been equipped with plugs and terminals or similar connectors by the customer.



#### WARNING

##### Hot motor housing

Risk of fire

- Ensure that no combustible or flammable materials are located close to the fan.
- ⇒ Before switching on, check the device for visible external damage and make sure the protective devices are functional.
- ⇒ Check the fan's air flow paths for foreign matter and remove any foreign matter found.
- ⇒ Apply the nominal supply voltage.
- ⇒ Start the device by changing the input signal.

#### 4.7 Switching off the device

Switching off the device during operation:

- ⇒ Switch off the device via the control input.
- ⇒ Do not switch the motor (e.g. in cyclic operation) on and off via power supply.

Switching off the device for maintenance:

- ⇒ Switch off the device via the control input.
- ⇒ Do not switch the motor (e.g. in cyclic operation) on and off via power supply.
- ⇒ Disconnect the device from the power supply.

## 5. MAINTENANCE, MALFUNCTIONS, POSSIBLE CAUSES AND REMEDIES

Do not perform any repairs on your device. Send the device to ebmpapst for repair or replacement.

#### WARNING

##### Live terminals and connections even with device switched off

Electric shock

- Wait five minutes after disconnecting the voltage at all poles before opening the device.

#### CAUTION

##### If control voltage or a stored speed set value is applied, the motor will restart automatically, e.g. after a power failure.

Risk of injury

- Keep out of the device danger zone.
- When working on the device, switch off the line voltage and ensure that it cannot be switched back on.
- After working on the device, remove any tools or other objects from the device.



If the device is out of use for some time, e.g. when in storage, we recommend switching it on for at least two hours to allow any condensation to evaporate and to move the bearings.

| Malfunction/fault                        | Possible cause                   | Possible remedy   |
|--|----------------------------------|---|
| <b>Impeller not running smoothly</b>     | Imbalance in rotating parts      | Clean the device; replace it if imbalance persists after cleaning. Make sure no weight clips are removed during cleaning.                         |
| <b>Motor not turning</b>                 | Mechanical blockage              | Switch off, isolate from supply and remove mechanical blockage.   |
|  | Line voltage faulty              | Check line voltage, restore power supply, apply control signal.   |
|  | Faulty connection                | Isolate from supply, correct connection; see connection diagram.  |
| <b>Motor/electronics overtemperature</b> | Deficient cooling                | Improve cooling. Let the device cool down. To reset the error message, switch off the line voltage for at least 25 s and then switch it on again. |
|  | Ambient temperature too high     | Reduce the ambient temperature. Reset by reducing control input to 0.   |
|  | Impermissible point of operation | Correct the operating point. Let the device cool down.  |





In the event of further malfunctions, contact ebm-papst.

## 5.1 Cleaning

### NOTE

#### Damage to the device during cleaning

Malfunction possible

→ Do not clean the device using a water jet or high-pressure cleaner. # Do not use any acid, alkali or solvent-based cleaning agents. # Do not use any pointed or sharp-edged objects for cleaning

## 5.2 Safety inspection

| What to check                                     | How to check      | How often               | What action?                    |
|---|-------------------|-------------------------|---------------------------------|
| Contact protection cover for intactness or damage | Visual inspection | At least every 6 months | Repair or replacement of device |
| Device for damage to blades and housing           | Visual inspection | At least every 6 months | Replacement of device           |
| Fastening the cables                              | Visual inspection | At least every 6 months | Fasten                          |
| Insulation of cables for damage                   | Visual inspection | At least every 6 months | Replace cables                  |
| Welds for crack formation                         | Visual inspection | At least every 6 months | Replace device                  |

## 5.3 Disposal

For ebm-papst, environmental protection and resource preservation are top priority corporate goals.

ebm-papst operates an environmental management system which is certified in accordance with ISO 14001 and rigorously implemented around the world on the basis of German standards.

Right from the development stage, ecological design, technical safety and health protection are fixed criteria.

The following section contains recommendations for ecological disposal of the product and its components.

### 5.3.1 Country-specific legal requirements



### NOTE

#### Country-specific legal requirements

Always observe the applicable country-specific legal regulations with regard to the disposal of products or waste occurring in the various phases of the life cycle. The corresponding disposal standards are also to be heeded.

### 5.3.2 Disassembly

Disassembly of the product must be performed or supervised by qualified personnel with the appropriate technical knowledge.

The product is to be disassembled into suitable components for disposal employing standard procedures for motors.



### WARNING

**Heavy parts of the product may drop off. Some of the product components are heavy. These components could drop off during disassembly.**

This can result in fatal or serious injury and material damage.

→ Secure components before unfastening to stop them falling.

### 5.3.3 Component disposal

The products are mostly made of steel, copper, aluminum and plastic.

Metallic materials are generally considered to be fully recyclable.

Separate the components for recycling into the following categories:

- Steel and iron
- Aluminum
- Non-ferrous metal, e.g. motor windings
- Plastics, particularly with brominated flame retardants, in accordance with marking
- Insulating materials
- Cables and wires
- Electronic scrap, e.g. circuit boards

Only ferrite magnets and not rare earth magnets are used in external rotor motors from ebm-papst Mulfingen GmbH & Co. KG.

⇒ Ferrite magnets can be disposed of in the same way as normal iron and steel.

Electrical insulating materials on the product, in cables and wires are made of similar materials and are therefore to be treated in the same manner.

The materials concerned are as follows:

- Miscellaneous insulators used in the terminal box
- Power cables
- Cables for internal wiring
- Electrolytic capacitors

Dispose of electronic components employing the proper procedures for electronic scrap.



→ Please contact ebm-papst for any other questions on disposal.

