

FEATURES

- SNR = 90 dB in 1.25 MHz bandwidth to Nyquist
- SNR = 87 dB in 1.25 MHz bandwidth to 200 MHz
- Integrated 14-bit, 92.16 MSPS ADC
- IF sampling frequencies to 200 MHz
- Internal 2.4 V reference, 2.2 V p-p analog input range
- Internal differential track-and-hold analog input
- Processes 4/6 wideband carriers simultaneously
- Fractional clock multiplier to 200 MHz
- Programmable decimating FIR filters, interpolating half-band filters and programmable AGC loops with 96 dB range
- Three 16-bit configurable parallel output ports
- User-configurable built-in self-test (BIST) capability
- 8-/16-bit microport and SPORT/SPI® serial port control

APPLICATIONS

- Multicarrier, multimode digital receivers
- GSM, EDGE, PHS, UMTS, WCDMA, CDMA2000, TD-SCDMA, WiMAX
- Micro and pico cell systems, software radios
- Wireless local loop
- Smart antenna systems
- In-building wireless telephony
- Broadband data applications
- Instrumentation and test equipment

FUNCTIONAL BLOCK DIAGRAM

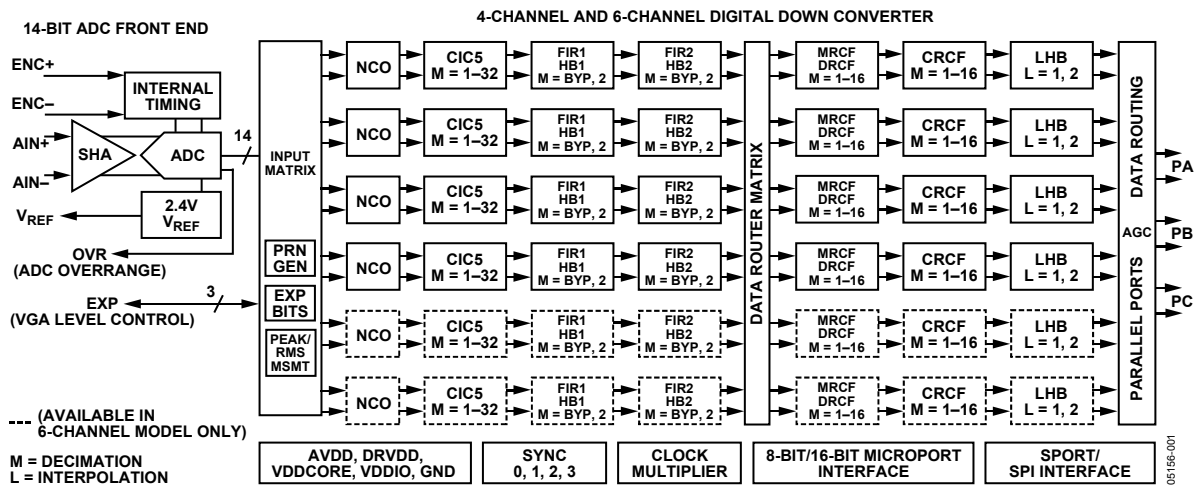

Figure 1.

Rev. 0

Information furnished by Analog Devices is believed to be accurate and reliable. However, no responsibility is assumed by Analog Devices for its use, nor for any infringements of patents or other rights of third parties that may result from its use. Specifications subject to change without notice. No license is granted by implication or otherwise under any patent or patent rights of Analog Devices. Trademarks and registered trademarks are the property of their respective owners.

TABLE OF CONTENTS

General Description	4	Input Crossbar Matrix	33
Product Highlights	5	Numerically Controlled Oscillator (NCO)	34
Specifications	6	NCO Frequency	34
Recommended Operating Conditions	6	Mixer	35
ADC DC Specifications	6	Bypass	35
ADC Digital Specifications	6	Clear Phase Accumulator on Hop	35
ADC Switching Specifications	7	Phase Dither	35
ADC AC Specifications	7	Amplitude Dither	35
Electrical Characteristics	8	NCO Frequency Hold-Off Register	35
Timing Characteristics	9	Phase Offset	35
Microport Timing Characteristics	10	HOP Sync	35
Serial Port Timing Characteristics	11	Fifth-Order CIC Filter	36
Timing Diagrams	12	Bypass	36
Absolute Maximum Ratings	18	CIC Rejection	36
Thermal Characteristics	18	Example Calculations	37
Explanation of Test Levels	18	FIR Half-Band Block	38
ESD Caution	18	3-Tap Fixed coefficient Filter (FIR1)	38
Pin Configuration and Function Descriptions	19	Decimate-by-2 Half-Band Filter (HB1)	38
Typical Performance Characteristics	22	6-Tap Fixed Coefficient Filter (FIR2)	39
ADC Equivalent Circuits	25	Decimate-by-2 Half-Band Filter (HB2)	39
Terminology	26	Intermediate Data Router	41
Theory of Operation	27	Mono-Rate RAM Coefficient Filter (MRCF)	42
ADC Architecture	27	Symmetry	42
Application information	28	Clock Rate	42
ADC Configuration Notes	28	Bypass	42
DDC Configuration Notes	29	Scaling	42
ADC Input Port Monitor Function	31	Decimating RAM Coefficient Filter (DRCF)	43
Peak Detector Mode	31	Bypass	43
Mean Power Mode	31	Scaling	43
Threshold Crossing Mode	32	Symmetry	43
Additional Control Bits	32	Coefficient Offset	43

Decimation Phase	43	HOP	58
Maximum Number of Taps Calculated.....	43	Serial Port Control.....	60
Programming DRCF Registers for an Asymmetrical Filter	44	Hardware Interface	60
Programming DRCF Registers for a Symmetric Filter	44	SPI Mode Timing.....	62
Channel RAM Coefficient Filter (CRCF)	45	SPORT Mode Timing.....	64
Bypass	45	Programming Indirect Addressed Registers Using Serial Port.....	67
Scaling.....	45	Connecting the AD6654 Serial Port to a Blackfin DSP	69
Symmetry	45	Microport	70
Coefficient Offset.....	45	Intel (Inm) Mode	70
Decimation Phase	45	Motorola (MNM) Mode	70
Maximum Number of TAPS Calculated.....	45	Accessing Multiple AD6654 Devices	71
Programming CRCF Registers for an Asymmetrical Filter	46	Memory Map	72
Programming CRCF Registers for a Symmetrical Filter	46	Reading the Memory Map Table.....	72
Interpolating Half-Band Filter.....	47	Bit Format	72
Output Data Router	48	Open Locations	72
Interleaving Data.....	48	Default Values.....	72
Automatic Gain Control.....	49	Logic Levels.....	72
AGC Loop	49	Global Register Map	74
Desired Signal Level Mode	50	Input Port Register Map.....	76
Desired Clipping Level Mode.....	52	Channel Register Map.....	78
AGC Synchronization.....	52	MRCF Coefficient Memory.....	79
SYNC Process	52	Output Port Register Map.....	82
Parallel Port Output	53	DDC Design Notes	85
Interleaved I/Q Mode	53	Outline Dimensions.....	87
Parallel IQ Mode	53	Ordering Guide	87
Master/Slave PCLK Modes	55		
Parallel Port Pin Functions	56		
User-Configurable Built-In Self-Test (BIST)	57		
Chip Synchronization	58		
Start.....	58		

REVISION HISTORY

4/05—Revision 0: Initial Version

GENERAL DESCRIPTION

The AD6654 is a mixed-signal IF-to-baseband receiver consisting of a 14-bit, 92.16 MSPS analog-to-digital converter (ADC) and a 4-/6-channel, multimode digital down-converter (DDC) capable of processing up to six WCDMA (wideband code division multiple access) channels. The AD6654 has been optimized for the demanding filtering requirements of wide-band standards such as CDMA2000, UMTS, and TD-SCDMA, but is flexible enough to support wider standards such as WiMAX. It is typically used as part of a radio system that digitally demodulates and filters IF sampled signals.

The ADC stage features a high performance track-and-hold input amplifier (T/H), integrated voltage reference, and 14-bit sampling resolution. Input signals up to 200 MHz can be accurately digitized at encode rates up to 92.16 MSPS. The ADC data outputs are internally routed directly into the DDC inputs, where down-conversion, decimation and digital filtering are performed. An overrange (OVR) output bit provides indication of excessive ADC input levels. An ADC data-ready (DR) output bit provides a synchronized clock for the integrated DDC.

Data from the ADC is evaluated for peak or mean power in the input stage of the DDC, and the result is available to the user via control register access. The DDC input stage also outputs 3-bit level-indicator data (EXP) bits that can be used to control the gain of the external DVGA in 6 dB steps (up to 48 dB) to optimize signal amplitude into the ADC input.

The DDC stage has the following signal processing stages: six WCDMA-ready channels, each consisting of a frequency translator, a fifth-order cascaded integrated comb filter, two sets of cascaded fixed coefficient FIR and half-band filters, three cascaded programmable sum of product FIR filters, an interpolating half-band filter (IHB), and a digital automatic gain control (AGC) block. Multiple modes are supported for clocking data out of the chip. Programming is accomplished via serial or microport interfaces.

Frequency translation is accomplished with a 32-bit complex numerically controlled oscillator (NCO). The NCO has greater than 110 dBc SDFR. This stage translates a real input signal from an intermediate frequency (IF) to a baseband complex digital output. Phase and amplitude dither can be enabled on-chip to improve spurious performance of the NCO. A 16-bit phase-offset word is available to create a known phase relationship between multiple AD6654 chips or channels. The NCO can also be bypassed.

Following frequency translation is a fifth-order CIC filter with a programmable decimation between 1 and 32. This filter is used to efficiently lower the sample rate, while providing sufficient alias rejection at frequencies at higher offsets from the signal of interest.

Following the CIC5 are two sets of filters. Each filter set includes a nondecimating FIR filter and a decimate-by-2 half-band filter. The FIR1 filter provides about 30 dB of rejection, while the HB1 provides about 77 dB of rejection. These two sets of filters can be used together to achieve a 107 dB stop-band alias rejection, or they can be individually bypassed to save power.

The FIR2 filter provides about 30 dB of rejection, while the HB2 filter provides about 65 dB of rejection. The filters can be used together to achieve more than 95 dB stop-band alias rejection, or they can be individually bypassed to save power. FIR1 and HB1 filters can run at the maximum ADC data port rate. In contrast, FIR2 and HB2 can run with a maximum input rate of 75 MSPS (input rate to FIR2 and HB2 filters).

The programmable filtering is divided into three cascaded RAM coefficient filters (RCFs) for flexible and power-efficient filtering. The first filter in the cascade is the MRCF, consisting of a programmable nondecimating FIR. It is followed by programmable FIR filters (DRCF) with decimation from 1 to 16. They can be used either together to provide high rejection filters, or independently to save power. The maximum input rate to the MRCF is one-fourth the PLL clock rate.

The CRCF (Channel RCF) is the last programmable FIR filter with programmable decimation from 1 to 16. It is typically used to meet the spectral mask requirements for the air standard of interest. This could be an RRC, antialiasing filter or any other real data filter. Decimation in preceding blocks is used to keep the input rate of this stage as low as possible for the best filter performance.

The last filter stage in the chain is an interpolate-by-2 half-band filter, which is used to up-sample the CRCF output to produce higher output oversampling. Signal rejection requirements for this stage are relaxed, because preceding filters have already filtered the blockers and adjacent carriers.

The DDC input port of the AD6654 has its own clock input used for latching the input data, as well as for providing the input for an onboard PLL clock multiplier. The output of the PLL clock is used for processing all filters and processing blocks beyond the data router following CIC filter. The PLL clock can be programmed to have a maximum clock rate of 200 MHz. Typically, the DDC input clock is driven directly from the integrated ADC's data-ready (DR) output to ensure proper synchronization.

A data routing block is used to distribute data from the CICs to the various channel filters. This block allows multiple back-end filter chains to work together to process high bandwidth signals or to make even sharper filter transitions than a single channel

can perform. It can also allow complex filtering operations to be achieved in the programmable filters.

The digital AGC provides the user with scaled digital outputs based on the rms level of the signal present at the output of the digital filters. The user can set the requested level and time constant of the AGC loop for optimum performance of the postprocessor. This is a critical function in the base station for CDMA application, where the power level must be well controlled going into the RAKE receivers. It has programmable clipping and rounding control to provide different output resolutions.

The overall filter response for the AD6654 is the composite of all the combined filter stages. Each successive filter stage is capable of narrower transition bandwidths, but requires a greater number of CLK cycles to calculate the output. The AD6654 features a fractional clock multiplier that uses the ADC clock (which is slower than the DDC's processing speed) to produce a DDC master clock up to 200 MHz. This feature allows fractional multiplication of the input clock to allow the DDC to function at maximum speed while maintaining edge identity to the ADC clock.

More decimation in the first filter stage minimizes overall power consumption. Data from the device is interfaced to a DSP/FPGA/baseband processor via high speed parallel ports (preferred), or a DSP-compatible microprocessor interface.

The AD6654 is available in 4-channel and 6-channel versions. The primary focus of the data sheet is on the 6-channel part. The only difference between the 6-channel and 4-channel devices is that, on the 4-channel version, Channel 4 and

Channel 5 are not available (see Figure 1). The 4-channel device has the same DDC input port features, output ports, and memory map as the 6-channel device. On the 4-channel version, the memory map section for Channel 4 and Channel 5 can be programmed and read back, but the two extra channels are disabled internally.

PRODUCT HIGHLIGHTS

1. Integrated 14-bit, 92.16 MSPS ADC.
2. Track-and-hold amplifier analog input for excellent IF sampling up to 200 MHz.
3. Four or six independent digital filtering channels.
4. RMS/peak power monitoring of the ADC data port and 96 dB range AGCs before the output ports.
5. Three programmable RAM coefficient filters, three half-band filters, two fixed coefficient filters, and one fifth-order CIC filter per channel.
6. Complex filtering by combining filtering capability of multiple channels.
7. Three 16-bit parallel output ports operating at up to 200 MHz clock.
8. Blackfin®- and TigerSHARC®-compatible, 8-/16-bit microprocessor port.
9. Synchronous serial communications port is compatible with most serial interface standards: SPORT, SPI, and SSR.

SPECIFICATIONS

RECOMMENDED OPERATING CONDITIONS

Table 1.

Parameter (Conditions)	Temp	Test Level	Min	Typ	Max	Unit
AVDD ¹	Full	IV	4.75	5.0	5.25	V
DRVDD ²	Full	IV	3.0	3.3	3.6	V
VDDCORE	Full	IV	1.65	1.8	1.95	V
VDDIO ²	Full	IV	3.0	3.3	3.6	V
T _{AMBIENT}		IV	-25	+25	+85	°C

¹ Specified for dc supplies with linear rise-time <250 ms.

² DRVDD and VDDIO can be operated from the same supply.

ADC DC SPECIFICATIONS

AVDD = 5.0 V, DRVDD = 3.3 V, VDDCORE = 1.8 V, VDDIO = 3.3 V, maximum rated sample rate, differential ENC and AIN, unless otherwise noted.

Table 2.

Parameter (Conditions)	Temp	Test Level	Min	Typ	Max	Unit
RESOLUTION	Full	IV		14		Bits
INTERNAL VOLTAGE REFERENCE (V _{REF}) ¹ Output Voltage	Full	IV		2.4		V
ANALOG INPUTS						
Differential Input Voltage Range	Full	IV		2.2		V p-p
Differential Input Capacitance	Full	V		1.5		pF
Differential Input Resistance	Full	V		1		kΩ
Power Supply Rejection (PSRR)	25°C	V		±1.0		mV/V

¹ V_{REF} is provided for setting the common-mode offset of a differential amplifier such as the AD8138 when a dc-coupled analog input is required. V_{REF} should be buffered if used to drive additional circuit functions.

ADC DIGITAL SPECIFICATIONS

AVDD = 5.0 V, DRVDD = 3.3 V, VDDCORE = 1.8 V, VDDIO = 3.3 V, maximum rated sample rate, differential ADC input, unless otherwise noted.

Table 3.

Parameter (Conditions)	Temp	Test Level	Min	Typ	Max	Unit
ENCODE INPUTS (ENC+, ENC-)						
Differential Input Voltage	Full	IV	0.4			V p-p
Differential Input Resistance	25°C	V		10		kΩ
Differential Input Capacitance	25°C	V		2.5		pF

ADC SWITCHING SPECIFICATIONS

AVDD = 5.0 V, DRVDD = 3.3 V, VDDCORE = 1.8 V, VDDIO = 3.3 V, maximum rated sample rate, differential input, unless otherwise noted.

Table 4.

Parameter (Conditions)	Temp	Test Level	Min	Typ	Max	Unit
SWITCHING PERFORMANCE						
Maximum Conversion Rate	Full	II	92.16			MSPS
Minimum Conversion Rate	Full	IV			30	MSPS
ENC Pulse Width High ¹ (t _{ENCH})	Full	IV	5.154	5.425		ns
ENC Pulse Width Low ¹ (t _{ENCL})	Full	IV	5.154	5.425		ns

¹ Several internal timing parameters are a function of t_{ENCL} and t_{ENCH}, optimum performance will be achieved with 50/50 duty cycle.

ADC AC SPECIFICATIONS

AVDD = 5.0 V, DRVDD = 3.3 V, VDDCORE = 1.8 V, VDDIO = 3.3 V, maximum rated sample rate, differential input, unless otherwise noted.

Table 5.

Parameter (Conditions)	Temp	Test Level	Min	Typ	Max	Unit
SIGNAL-TO-NOISE RATIO ¹ (WITHOUT HARMONICS)						
Analog Input Frequency 37 MHz						
ADC (46.08 MHz BW)	25°C	V		74.5		dB
CDMA (1.25 MHz BW)	Full	II	88	90.0		dB
WCDMA (5.0 MHz BW)	25°C	V		84		dB
Analog Input Frequency 70 MHz						
ADC (46.08 MHz BW)	25°C	V		73.5		dB
CDMA (1.25 MHz BW)	Full	II	87.5	89		dB
WCDMA (5.0 MHz BW)	25°C	V		83		dB
Analog Input Frequency 150 MHz						
ADC (46.08 MHz BW)	25°C	V		73		dB
CDMA (1.25 MHz BW)	25°C	V		88		dB
WCDMA (5.0 MHz BW)	25°C	V		82		dB
Analog Input Frequency 200 MHz						
ADC (46.08 MHz BW)	25°C	V		72		dB
CDMA (1.25 MHz BW)	25°C	V		87		dB
WCDMA (5.0 MHz BW)	25°C	V		81		dB
WORST HARMONIC ² (ANALOG INPUT @ -1 dBFS)						
37 MHz	Full	II	85	93		dBc
70 MHz	Full	V		91		dBc
150 MHz	Full	V		71		dBc
200 MHz	Full	V		63		dBc
INTERMODULATION DISTORTION (TWO-TONES SEPARATED BY 1 MHz) ³						
Analog Input = 55/56 MHz	25°C	V		90		dBc
ANALOG INPUT BANDWIDTH						
	25°C	V		270		MHz

¹ Analog input = -1 dB below full scale.

² Includes Harmonic 2 through Harmonic 6.

³ Analog input = each -7 dB below full scale.

AD6654

ELECTRICAL CHARACTERISTICS

AVDD = 5.0 V, DRVDD = 3.3 V, VDDCORE = 1.8 V, VDDIO = 3.3 V, maximum rated sample rate, differential input, unless otherwise noted.

Table 6.

Parameter (Conditions)	Temp	Test Level	Min	Typ	Max	Unit
LOGIC INPUTS (NOT 5 V TOLERANT)						
Logic Compatibility	Full	IV		3.3 V CMOS		
Logic 1 Voltage	Full	IV	2.0		3.6	V
Logic 0 Voltage	Full	IV	-0.3		+0.8	V
Logic 1 Current	Full	IV		1	10	μA
Logic 0 Current	Full	IV		1	10	μA
Logic 1 Current (Inputs With Pull-Down)	Full	IV				
Logic 0 Current (Inputs With Pull-Up)	Full	IV				
Input Capacitance	25°C	V		4		pF
LOGIC OUTPUTS						
Logic Compatibility	Full	IV		3.3 V CMOS		
Logic 1 Voltage (I _{OH} = 0.25 mA)	Full	IV	2.4	VDDIO - 0.2		V
Logic 0 Voltage (I _{OL} = 0.25 mA)	Full	IV		0.2	0.4	V
SUPPLY CURRENTS						
WCDMA (92.16 MSPS) EXAMPLE¹						
I _{AVDD}	25°C	V		275		mA
I _{DRVDD}	25°C	V		32		mA
I _{VDD}	25°C	V		460		mA
I _{VDDIO}	25°C	V		60		mA
CDMA2000 (92.16 MSPS) EXAMPLE¹						
I _{AVDD}	25°C	V		275		mA
I _{DRVDD}	25°C	V		32		mA
I _{VDD}	25°C	V		435		mA
I _{VDDIO}	25°C	V		25		mA
TDS-CDMA (76.8 MSPS) EXAMPLE^{1,2}						
I _{AVDD}	25°C	V		275		mA
I _{DRVDD}	25°C	V		32		mA
I _{VDD}	25°C	V		250		mA
I _{VDDIO}	25°C	V		15		mA
TOTAL POWER DISSIPATION						
WCDMA (92.16 MSPS) ¹	25°C	V		2.5		W
CDMA2000 (92.16 MSPS) ¹	25°C	V		2.3		W
TDS-CDMA (76.8 MSPS) ^{1,2}	25°C	V		2.0		W

¹ ADC input port, all six DDC channels, and the relevant signal processing blocks are active.

² PLL is turned off for power savings.

TIMING CHARACTERISTICS

Table 7.

Parameter ^{1,2,3}	Temp	Test Level	Min	Typ	Max	Unit
CLK TIMING REQUIREMENTS						
t _{CLK} CLK Period	Full	IV		10.85		ns
t _{CLKL} CLK Width Low	Full	IV	5.154	0.5 × t _{CLK}		ns
t _{CLKH} CLK Width High	Full	IV	5.154	0.5 × t _{CLK}		ns
INPUT WIDEBAND DATA TIMING REQUIREMENTS						
t _{DEXP} ↑CLK to EXP[2:0] Delay	Full	IV	5.98		10.74	ns
PARALLEL OUTPUT PORT TIMING REQUIREMENTS (MASTER)						
t _{DPREQ} ↑PCLK to ↑Px REQ Delay (x = A, B, C)	Full	IV	1.77		3.86	ns
t _{DPP} ↑PCLK to Px[15:0] Delay (x = A, B, C)	Full	IV	2.07		5.29	ns
t _{DPIQ} ↑PCLK to Px IQ Delay (x = A, B, C)	Full	IV	0.48		5.49	ns
t _{DPCH} ↑PCLK to Px CH[2:0] Delay (x = A, B, C)	Full	IV	0.38		5.35	ns
t _{DPGAIN} ↑PCLK to Px Gain Delay (x = A, B, C)	Full	IV	0.23		4.95	ns
t _{SPA} Px ACK to ↑PCLK Setup Time (x = A, B, C)	Full	IV	4.59			ns
t _{HPA} Px ACK to ↑PCLK Hold Time (x = A, B, C)	Full	IV	0.90			ns
PARALLEL OUTPUT PORT TIMING REQUIREMENTS (SLAVE)						
t _{PCLK} PCLK Period	Full	IV	5.0			ns
t _{PCLKL} PCLK Low Period	Full	IV	1.7	0.5 × t _{PCLK}		ns
t _{PCLKH} PCLK High Period	Full	IV	0.7	0.5 × t _{PCLK}		ns
t _{DPREQ} ↑PCLK to ↑Px REQ Delay (x = A, B, C)	Full	IV	4.72		8.87	ns
t _{DPP} ↑PCLK to Px[15:0] Delay (x = A, B, C)	Full	IV	4.8		8.48	ns
t _{DPIQ} ↑PCLK to Px IQ Delay (x = A, B, C)	Full	IV	4.83		10.94	ns
t _{DPCH} ↑PCLK to Px CH[2:0] Delay (x = A, B, C)	Full	IV	4.88		10.09	ns
t _{DPGAIN} ↑PCLK to Px Gain Delay (x = A, B, C)	Full	IV	5.08		11.49	ns
t _{SPA} Px ACK to ↓PCLK Setup Time (x = A, B, C)	Full	IV	6.09			ns
t _{HPA} Px ACK to ↓PCLK Hold Time (x = A, B, C)	Full	IV	1.0			ns
MISC PINS TIMING REQUIREMENTS						
t _{RESET} $\overline{\text{RESET}}$ Width Low	Full	IV	30			ns
t _{DIRP} CPUCLK/SCLK to $\overline{\text{IRP}}$ Delay	Full	V	7.5			ns
t _{SSYNC} SYNC(0, 1, 2, 3) to ↑CLK Setup Time	Full	IV	0.87			ns
t _{HSYNC} SYNC(0, 1, 2, 3) to ↑CLK Hold Time	Full	IV	0.67			ns

¹ All timing specifications are valid over the VDDCORE range of 1.7 V to 1.9 V, and the VDDIO range of 3.0 V to 3.6 V.

² C_{LOAD} = 40 pF on all outputs, unless otherwise noted.

³ These timing parameters are derived from the ADC ENC rate with DDC CLK driven directly from ADC DR output.

MICROPORT TIMING CHARACTERISTICS

Table 8.

Parameter ^{1,2}	Temp	Test Level	Min	Typ	Max	Unit
MICROPORT CLOCK TIMING REQUIREMENTS						
t _{CPUCLK}		Full	IV	10.0		ns
t _{CPUCLKL}	CPUCLK Low Time	Full	IV	1.53	0.5 × t _{CPUCLK}	ns
t _{CPUCLKH}	CPUCLK High Time	Full	IV	1.70	0.5 × t _{CPUCLK}	ns
INM MODE WRITE TIMING (MODE = 0)						
t _{SC}	Control ³ to ↑CPUCLK Setup Time	Full	IV	0.80		ns
t _{HC}	Control ³ to ↑CPUCLK Hold Time	Full	IV	0.09		ns
t _{SAM}	Address/Data to ↑CPUCLK Setup Time	Full	IV	0.76		ns
t _{HAM}	Address/Data to ↑CPUCLK Hold Time	Full	IV	0.20		ns
t _{DRDY}	↑CPUCLK to RDY (\overline{DTACK}) Delay	Full	IV	3.51	6.72	ns
t _{ACC}	Write Access Time	Full	IV	3 × t _{CPUCLK}	9 × t _{CPUCLK}	ns
INM MODE READ TIMING (MODE = 0)						
t _{SC}	Control ³ to ↑CPUCLK Setup Time	Full	IV		1.00	ns
t _{HC}	Control ³ to ↑CPUCLK Hold Time	Full	IV		0.03	ns
t _{SAM}	Address to ↑CPUCLK Setup Time	Full	IV		0.80	ns
t _{HAM}	Address to ↑CPUCLK Hold Time	Full	IV		0.20	ns
t _{DD}	↑CPUCLK to Data Delay	Full	V		5.0	ns
t _{DRDY}	↑CPUCLK to RDY (\overline{DTACK}) Delay	Full	IV	4.50	6.72	ns
t _{ACC}	Read Access Time	Full	IV	3 × t _{CPUCLK}	9 × t _{CPUCLK}	ns
MNM MODE WRITE TIMING (MODE = 1)						
t _{SC}	Control ³ to ↑CPUCLK Setup Time	Full	IV	1.00		ns
t _{HC}	Control ³ to ↑CPUCLK Hold Time	Full	IV	0.00		ns
t _{SAM}	Address/Data to ↑CPUCLK Setup Time	Full	IV	0.00		ns
t _{HAM}	Address/Data to ↑CPUCLK Hold Time	Full	IV	0.57		ns
t _{DDTACK}	↑CPUCLK to \overline{DTACK} (RDY) Delay	Full	IV	4.10	5.72	ns
t _{ACC}	Write Access Time	Full	IV	3 × t _{CPUCLK}	9 × t _{CPUCLK}	ns
MNM MODE READ TIMING (MODE = 1)						
t _{SC}	Control ³ to ↑CPUCLK Setup Time	Full	IV	1.00		ns
t _{HC}	Control ³ to ↑CPUCLK Hold Time	Full	IV	0.00		ns
t _{SAM}	Address to ↑CPUCLK Setup Time	Full	IV	0.00		ns
t _{HAM}	Address to ↑CPUCLK Hold Time	Full	IV	0.57		ns
t _{DD}	CPUCLK to Data Delay	Full	V		5.0	ns
t _{DDTACK}	↑CPUCLK to \overline{DTACK} (RDY) Delay	Full	IV	4.20	6.03	ns
t _{ACC}	Read Access Time	Full	IV	3 × t _{CPUCLK}	9 × t _{CPUCLK}	ns

¹ All timing specifications are valid over the VDDCORE range of 1.7 V to 1.9 V, and the VDDIO range of 3.0 V to 3.6 V.

² C_{LOAD} = 40 pF on all outputs, unless otherwise noted.

³ Specification pertains to control signals: R/W, (WR), \overline{DS} , (\overline{RD}), and \overline{CS} .

SERIAL PORT TIMING CHARACTERISTICS

Table 9.

Parameter ^{1,2,3}		Temp	Test Level	Min	Typ	Max	Unit
SERIAL PORT CLOCK TIMING REQUIREMENTS							
t _{SCLK}	SCLK Period	Full	IV	10.0			ns
t _{SCLKL}	SCLK Low Time	Full	IV	1.60	0.5 × t _{SCLK}		ns
t _{SCLKH}	SCLK High Time	Full	IV	1.60	0.5 × t _{SCLK}		ns
SPI PORT CONTROL TIMING REQUIREMENTS (MODE = 0)							
t _{SSDI}	SDI to ↑SCLK Setup Time	Full	IV	1.30			ns
t _{HSDI}	SDI to ↑SCLK Hold Time	Full	IV	0.40			ns
t _{SSCS}	\overline{SCS} to ↑SCLK Setup Time	Full	IV	4.12			ns
t _{HSCS}	\overline{SCS} to ↑SCLK Hold Time	Full	IV	-2.78			ns
t _{DSDO}	↑SCLK to SDO Delay Time	Full	IV	4.28		7.96	ns
SPORT MODE CONTROL TIMING REQUIREMENTS (MODE = 1)							
t _{SSDI}	SDI to ↑SCLK Setup Time	Full	IV	0.80			ns
t _{HSDI}	SDI to ↑SCLK Hold Time	Full	IV	0.40			ns
t _{SSRFS}	SRFS to ↓SCLK Setup Time	Full	IV	1.60			ns
t _{HSRFS}	SRFS to ↓SCLK Hold Time	Full	IV	-0.13			ns
t _{SSSTFS}	STFS to ↓SCLK Setup Time	Full	IV	1.60			ns
t _{HSTFS}	STFS to ↓SCLK Hold Time	Full	IV	-0.30			ns
t _{SSCS}	\overline{SCS} to ↑SCLK Setup Time	Full	IV	4.12			ns
t _{HSCS}	\overline{SCS} to ↑SCLK Hold Time	Full	IV	-2.76			ns
t _{DSDO}	↑SCLK to SDO Delay Time	Full	IV	4.29		7.95	ns

¹ All timing specifications are valid over the VDDCORE range of 1.7 V to 1.9 V and the VDDIO range of 3.0 V and 3.6 V.² C_{LOAD} = 40 pF on all outputs, unless otherwise noted.³ SCLK rise/fall time should be 3 ns maximum.

TIMING DIAGRAMS



Figure 2. Reset Timing Requirements

05156-002

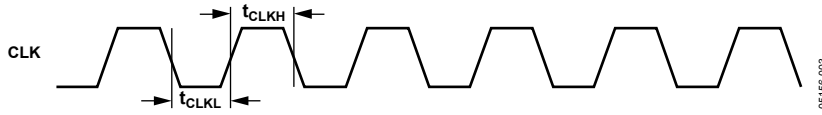

Figure 3. CLK Switching Characteristics

05156-003

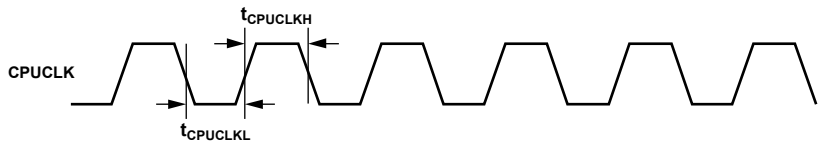

Figure 4. CPUCLK Switching Characteristics

05156-004

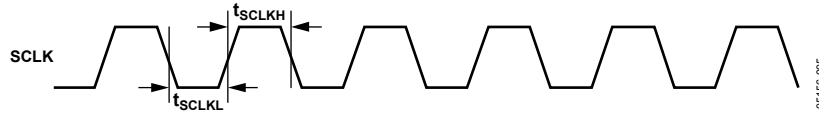

Figure 5. SCLK Switching Characteristics

05156-005

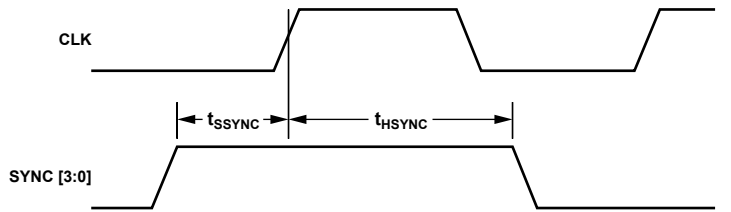

Figure 6. SYNC Timing Inputs

05156-006

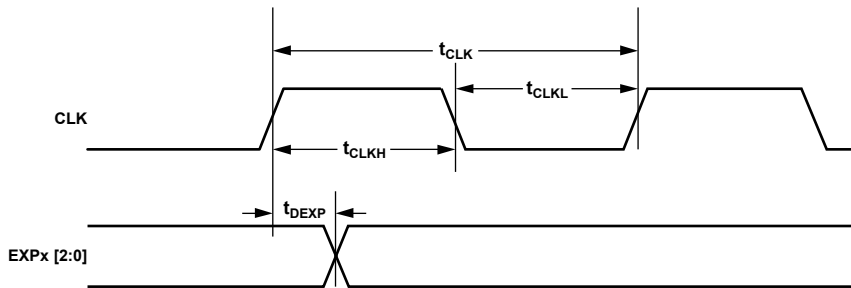

Figure 7. Gain Control Word Output Switching Characteristics

05156-007

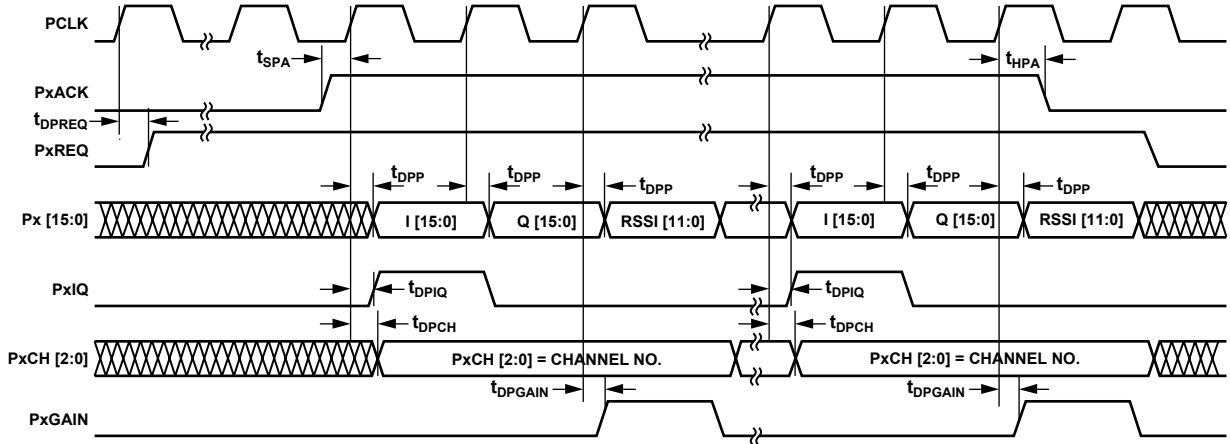

Figure 8. Master Mode PxAck to PCLK Switching Characteristics

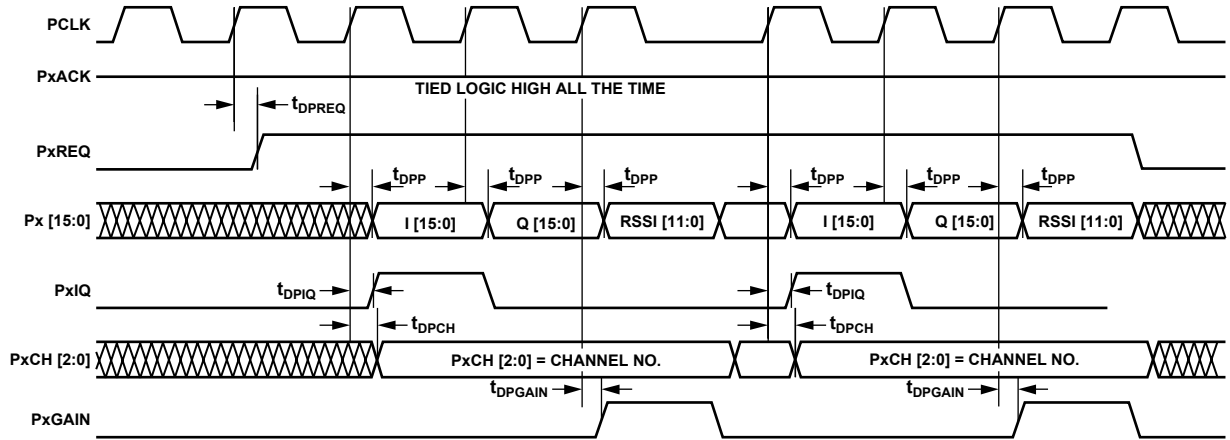
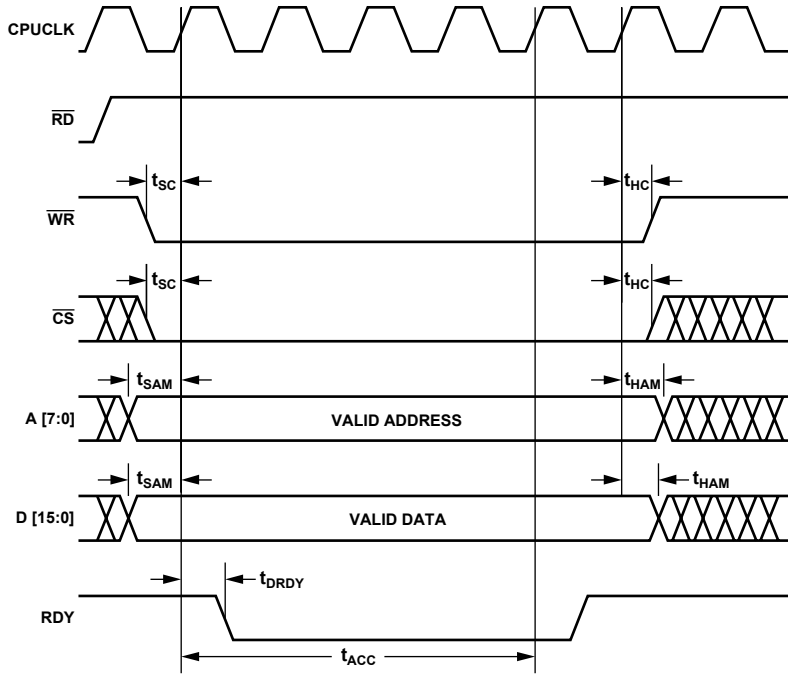

Figure 9. Master Mode PxDREQ to PCLK Switching Characteristics



NOTE:
 t_{Acc} ACCESS TIME DEPENDS ON THE ADDRESS ACCESSED. IT CAN VARY FROM 3 TO 9 CPUCLK CYCLES.

05156-010

Figure 10. INM Microport Write Timing Requirements

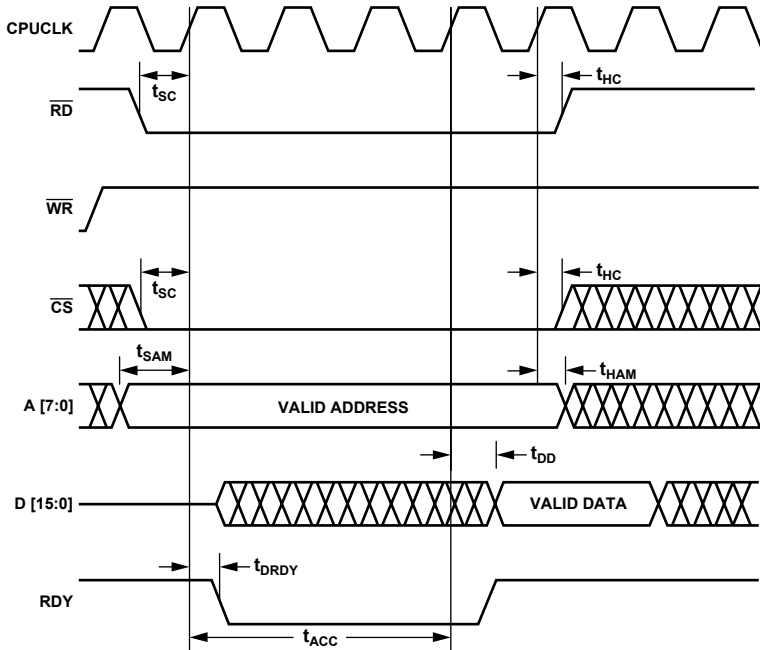

NOTE:
 t_{Acc} ACCESS TIME DEPENDS ON THE ADDRESS ACCESSED. IT CAN VARY FROM 3 TO 9 CPUCLK CYCLES.

05156-011

Figure 11. INM Microport Read Timing Requirements

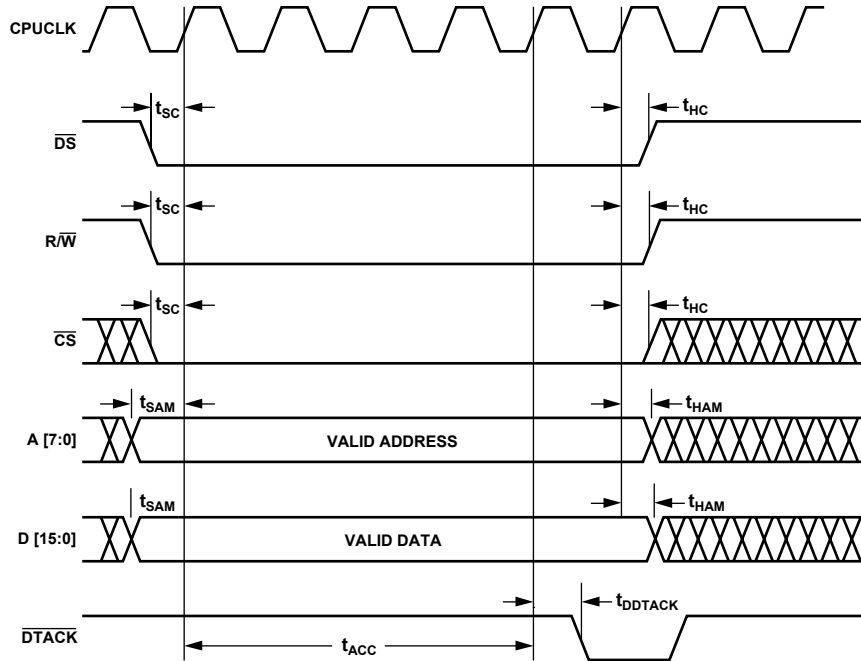

NOTE:
 t_{ACC} ACCESS TIME DEPENDS ON THE ADDRESS ACCESSED. IT CAN VARY FROM 3 TO 9 CPUCLK CYCLES.

05156-012

Figure 12. MNM Microport Write Timing Requirements

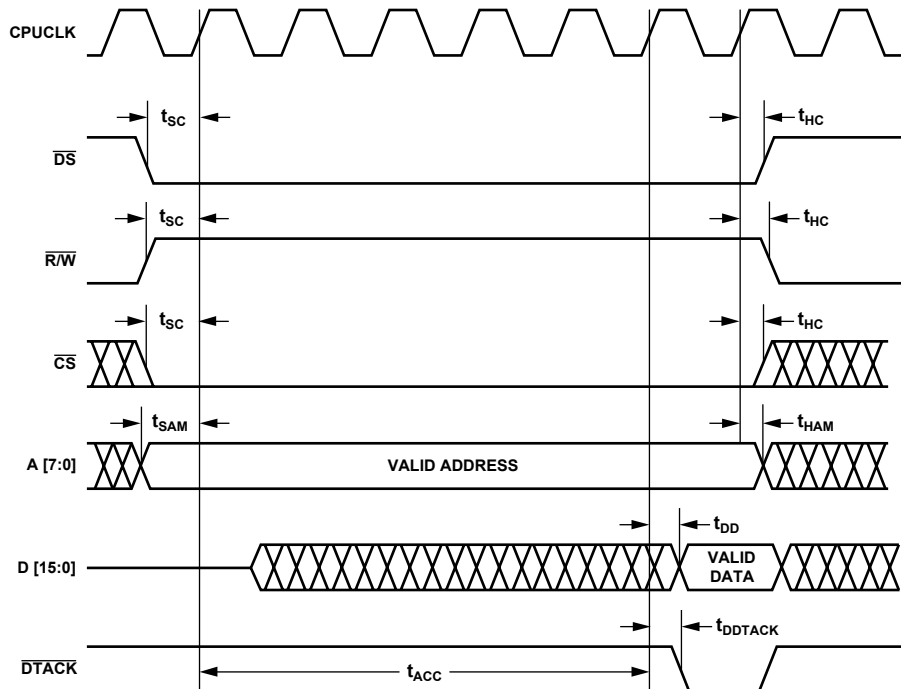

NOTE:
 t_{ACC} ACCESS TIME DEPENDS ON THE ADDRESS ACCESSED. IT CAN VARY FROM 3 TO 9 CPUCLK CYCLES.

05156-013

Figure 13. MNM Microport Read Timing Requirements

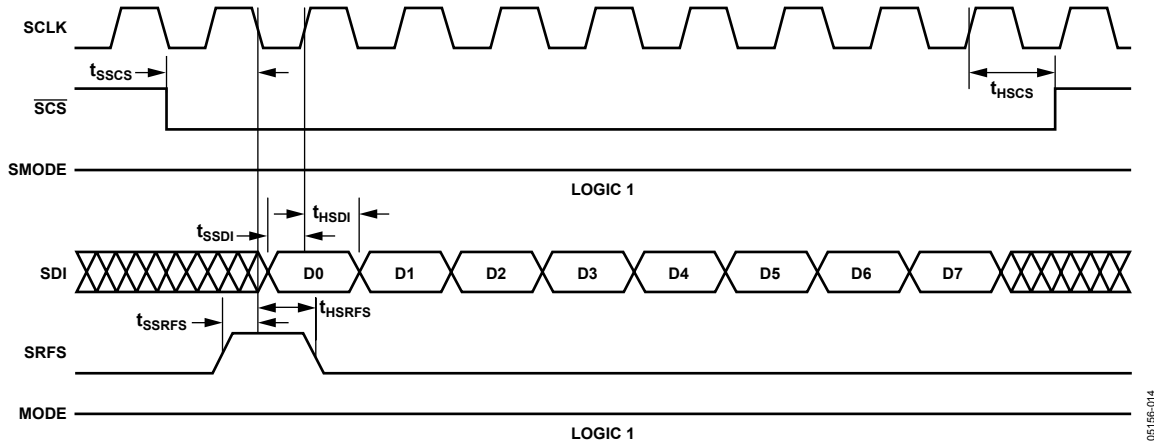

05156-014

Figure 14. SPORT Mode Write Timing Characteristics

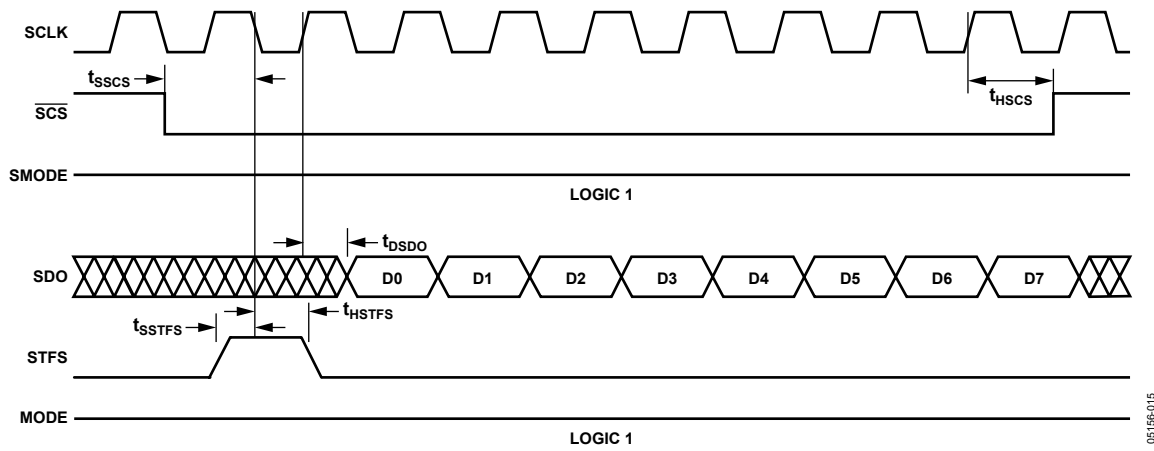

05156-015

Figure 15. SPORT Mode Read Timing Characteristics

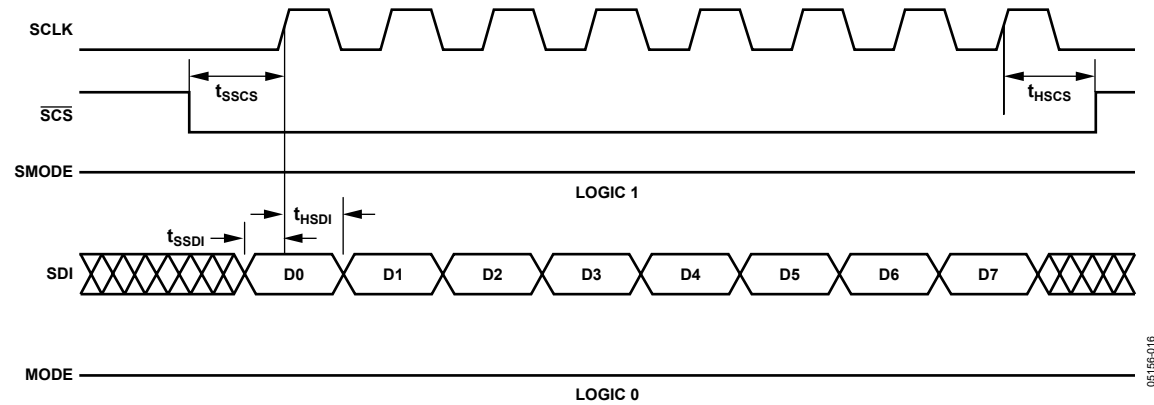

05156-016

Figure 16. SPI Mode Write Timing Characteristics

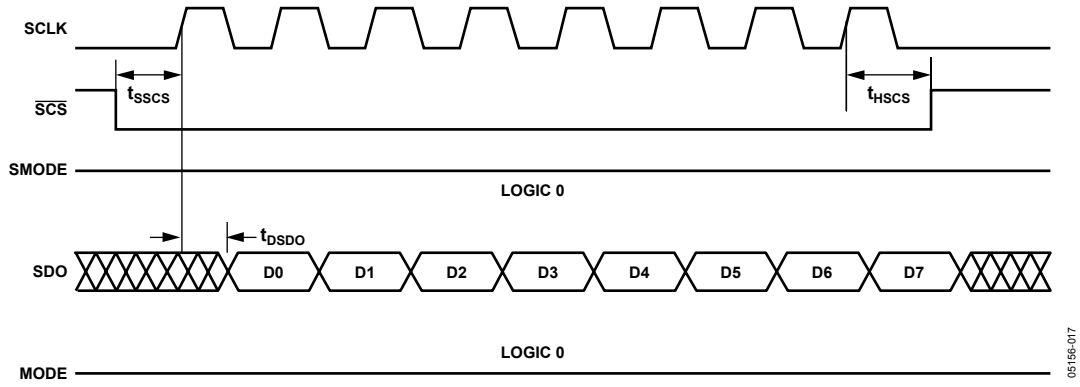

05156-07

Figure 17. SPI Mode Read Timing Characteristics

ABSOLUTE MAXIMUM RATINGS

Table 10.

Parameter	Rating
AVDD	0 to +7.0 V
DRVDD	0 to +4.0 V
VDDCORE	-0.3 V to +2.2 V
VDDIO	0 to +4.0 V
Analog/Encode Input Voltage	0 to AVDD
Analog Input Current	25 mA
Digital Input Voltage	-0.3 V to + 3.6 V (not 5 V tolerant)
Digital Output Voltage	-0.3 V to VDDIO + 0.3 V
Operating Temperature Range (Ambient)	-25°C to +85°C
Junction Temperature Under Bias	150°C
Storage Temperature Range	-65°C to +150°C

Stresses above those listed under Absolute Maximum Ratings may cause permanent damage to the device. This is a stress rating only; functional operation of the device at these or any other conditions above those indicated in the operational section of this specification is not implied. Exposure to absolute maximum rating conditions for extended periods may affect device reliability.

THERMAL CHARACTERISTICS

256 BGA, 17 mm sq.

$\theta_{JA} = 21^{\circ}\text{C}/\text{W}$, no airflow.

Estimate based on JEDEC JC51-2 model using horizontally positioned 4-layer board.

EXPLANATION OF TEST LEVELS

Test Level	Description
I	100% production tested.
II	100% production tested at 25°C.
III	Sample tested only.
IV	Parameter guaranteed by design and analysis.
V	Parameter is typical value only.

ESD CAUTION

ESD (electrostatic discharge) sensitive device. Electrostatic charges as high as 4000 V readily accumulate on the human body and test equipment and can discharge without detection. Although this product features proprietary ESD protection circuitry, permanent damage may occur on devices subjected to high energy electrostatic discharges. Therefore, proper ESD precautions are recommended to avoid performance degradation or loss of functionality.



PIN CONFIGURATION AND FUNCTION DESCRIPTIONS

	1	2	3	4	5	6	7	8	9	10	11	12	13	14	15	16	
A	DGND	D14	D12	CPUCLK (SCLK)	PC3	PCCH1	PA12	PAIQ	PAGAIN	PB6	CLK	OVR	AVDD	AVDD	AGND	AGND	A
B	D7	CHIPID3	CHIPID2	DS (RD, SRFS)	PC5	PA5	PA15	PAACK	PB2	PB4	EXPC2	DNC	AVDD	AVDD	AGND	AGND	B
C	CHIPID0	MODE	DTACK (RDY, SDO)	R/W (WR, STFS)	PC0	PA3	PA9	PACH2	PB3	PB9	EXPC1	AVDD	AVDD	AVDD	AGND	AGND	C
D	EXT_FILTER	MSB_FIRST	CS (SCS)	PC6	PC2	PA1	PA7	PACH0	PB0	PB15	EXPC0	DRVDD	AVDD	AVDD	AGND	AGND	D
E	CHIPID1	IRP	VDDIO	VDD CORE	PCACK	VDD CORE	VDD CORE	VDD CORE	VDDIO	VDDIO	VDDIO	DRVDD	AVDD	AVDD	AGND	AGND	E
F	SMODE	D13	D15	RESET	D1	VDD CORE	VDD CORE	VDD CORE	VDDIO	VDDIO	VDDIO	DRVDD	AVDD	AVDD	AGND	C2	F
G	DGND	D8	D9	D2	D5	DGND	DGND	DGND	DGND	DGND	DGND	DRVDD	AVDD	AVDD	AGND	AGND	G
H	D3	D11	D4	D10	A6	DGND	DGND	DGND	DGND	DGND	DGND	DRVDD	AVDD	AVDD	AGND	C1	H
J	DGND	D6	D0	A7	A1	DGND	DGND	DGND	DGND	DGND	DGND	DRVDD	AVDD	AVDD	AGND	AGND	J
K	A5	A4	A0 (SDI)	A2	PC8	DGND	DGND	DGND	DGND	DGND	DGND	DRVDD	AVDD	AVDD	AGND	AGND	K
L	A3	PC12	PC11	PC15	PC10	VDDIO	VDDIO	VDDIO	VDD CORE	VDD CORE	VDD CORE	DRVDD	AVDD	AVDD	AGND	AIN-	L
M	PC14	PC13	PC9	PC7	PCCH0	VDDIO	VDDIO	VDDIO	VDD CORE	VDD CORE	VDD CORE	DRVDD	AVDD	AVDD	AGND	AIN+	M
N	PC1	PC4	PA13	PA8	PA0	PAREQ	PB1	PBREQ	DGND	DGND	DGND	DRVDD	AVDD	AVDD	AGND	AGND	N
P	PCIQ	PCREQ	PA14	PA10	PB10	PB7	PB8	PBCH1	PBACK	PBCH0	SYNC2	DRVDD	AVDD	AVDD	AGND	AGND	P
R	PCCH2	PCGAIN	PA6	PA2	PACH1	PB13	PB11	PBCH2	PB14	PBGAIN	SYNC1	DRVDD	AGND	AGND	AGND	ENC-	R
T	DGND	PA11	PA4	PCLK	PB5	PB12	PBIQ	DGND	DNC	SYNC0	SYNC3	DR	AGND	VREF	AGND	ENC+	T
	1	2	3	4	5	6	7	8	9	10	11	12	13	14	15	16	

DNC = DO NOT CONNECT

05156-018

Figure 18. 256 BGA Configuration (Top View)

Table 11. Pin Function Descriptions

Name	Type	Pin Number	Function
POWER SUPPLY			
AVDD	Power	See Table 12	5 V Analog ADC Core Supply.
DRVDD	Power	See Table 12	3.3 V ADC Output Driver Supply.
VDDCORE	Power	See Table 12	1.8 V Digital DDC Core Supply.
VDDIO	Power	See Table 12	3.3 V Digital DDC I/O Supply.
DGND	Ground	See Table 12	Digital Core and I/O Ground.
AGND	Ground	See Table 12	Analog ADC Ground.
ADC INPUTS			
AIN+	Input	M16	Differential Analog Input.
AIN-	Input	L16	Differential Analog Input.
ENC+	Input	T16	Differential Encode Input. Conversion initiated on rising edge.
ENC-	Input	R16	Differential Encode Input.
ADC OUTPUTS			
DR	Output	T12	Data Ready. Inverted and delayed representation of ENC+ used for driving the DDC CLK input.
OVR	Output	A12	Overrange Bit. A logic high indicates analog input exceeds $\pm FS$.
VREF	Output	T14	2.4 V Fixed Internal Voltage Reference. Bypass to AGND with 0.1 μF chip capacitor.
C1	Output	H16	Compensation Pin for ADC Voltage Reference. Bypass to AGND with 0.1 μF chip capacitor.
C2	Output	F16	Compensation Pin for ADC Voltage Reference. Bypass to AGND with 0.1 μF chip capacitor.

AD6654

Name	Type	Pin Number	Function
DDC INPUTS			
CLK	Input	A11	DDC Clock Input.
SYNC0	Input	T10	Synchronization Input 0. SYNC pins are independent of channels.
SYNC1	Input	R11	Synchronization Input 1.
SYNC2	Input	P11	Synchronization Input 2.
SYNC3	Input	T11	Synchronization Input 3.
DDC OUTPUTS			
EXPC[2:0]	Output	D11, C11, B11	External VGA Gain Control Bits. GND all pins if not used.
DDC OUTPUT PORTS			
PCLK	Bi-dir	T4	Parallel Output Port Clock. PCLK is bi-directional: master mode = output, slave mode = input.
PADATA[15:0]	Output	See Table 12	Parallel Output Port A Data Bus.
PACH[2:0]	Output	D8, R5, C8	Channel Indicator Output Port A.
PAIQ	Output	A8	Parallel Port A I/Q Data Indicator. Logic 1 indicates I data on data bus.
PAGAIN	Output	A9	Parallel Port A Gain Word Output Indicator. Logic 1 indicates gain word on data bus.
PAACK	Input	B8	Parallel Port A Acknowledge (Active High).
PAREQ	Output	N6	Parallel Port A Request (Active High).
PBDATA[15:0]	Output	See Table 12	Parallel Output Port B Data Bus.
PBCH[2:0]	Output	P10, P8, R8	Channel Indicator Output Port B.
PBIQ	Output	T7	Parallel Port B I/Q Data Indicator. Logic 1 indicates I data on data bus.
PBGAIN	Output	R10	Parallel Port B Gain Word Output Indicator. Logic 1 indicates gain word on data bus.
PBACK	Input	P9	Parallel Port B Acknowledge (Active High).
PBREQ	Output	N8	Parallel Port B Request (Active High)
PCDATA[15:0]	Output	See Table 12	Parallel Output Port C Data Bus.
PCCH[2:0]	Output	M5, A6, R1	Channel Indicator Output Port C.
PCIQ	Output	P1	Parallel Port C I/Q Data Indicator. Logic 1 indicates I data on data bus.
PCGAIN	Output	R2	Parallel Port C Gain word Output Indicator. Logic 1 indicates gain word on data bus.
PCACK	Input	E5	Parallel Port C Acknowledge (Active High).
PCREQ	Output	P2	Parallel Port C Request (Active High).
MICROPORT CONTROL			
D[15:0]	Bi-Dir	See Table 12	Bidirectional Microport Data. This bus is three-stated when \overline{CS} is high.
A[7:0]	Input	See Table 12	Microport Address Bus.
\overline{DS} (\overline{RD})	Input	B4	Active Low Data Strobe, MODE = 1. Active low read strobe when MODE = 0.
\overline{DTACK} (RDY) ¹	Output	C3	Active Low Data Acknowledge, MODE = 1. Microport status pin when MODE = 0. Terminate to VDDIO through external 1 k Ω pull-up resistor.
$\overline{R/W}$ (\overline{WR})	Input	C4	Read/Write Strobe, MODE = 1. Active low write strobe when MODE = 0.
MODE	Input	C2	Mode Select. Logic 0 = Intel [®] mode, Logic 1 = Motorola mode.
\overline{CS}	Input	D3	Active Low Chip Select. Logic 1 three-states the microport data bus.
CPUCLK	Input	A4	Microport CLK Input. (Input only.)
CHIPID[3:0]	Input	C1, E1, B3, B2	Chip ID Input Pins.
SERIAL PORT CONTROL			
SCLK	Input	A4	Serial Clock. Should have a rise/fall time of 3ns max.
SDO ¹	Output	C3	Serial Port Data Output. Terminate to VDDIO through external 1 k Ω pull-up resistor.
SDI ²	Input	K3	Serial Port Data Input.
STFS	Input	C4	Serial Transmit Frame Sync.
SRFS	Input	B4	Serial Receive Frame Sync.
\overline{SCS}	Input	D3	Serial Chip Select.
MSB_FIRST	Input	D2	Most Significant Bit_First. Selects MSB_FIRST into SDI pin, and MSB_FIRST out of SDO pin. Logic 1 = MSB_FIRST; Logic 0 = LSB_FIRST
SMODE	Input	F1	Serial Mode Select.
MISC PINS			
DNC	-----	B12, T9	Do Not Connect.
\overline{IRP} ¹	Output	E2	Interrupt Pin (Active Low). Terminate to VDDIO through external 1 k Ω pull-up resistor.
\overline{RESET}	Input	F4	Master Reset, Active Low.
EXT_FILTER	Input	D1	PLL Loop Filter (Analog Pin). Connect to VDDCORE through series 250 Ω and 0.01 μ F capacitor.

¹ Pins with internal pull-up resistor of nominal 70 k Ω .

² Pins with internal pull-down resistor of nominal 70 k Ω .

Table 12. Pin Listing for Power, Ground, and Data Buses

Name	Pin Number
AVDD	A13, A14, B13, B14, C12, C13, C14, D13, D14, E13, E14, F13, F14, G13, G14, H13, H14, J13, J14, K13, K14, L13, L14, M13, M14, N13, N14, P13, P14
AGND	A15, A16, B15, B16, C15, C16, D15, D16, E15, E16, F15, G15, G16, H15, J15, J16, K15, K16, L15, M15, N15, N16, P15, P16, R13, R14, R15, T13, T15
DRVDD	D12, E12, F12, G12, H12, J12, K12, L12, M12, N12, P12, R12
VDDIO	E3, E9, E10, E11, F9, F10, F11, L6, L7, L8, M6, M7, M8
VDDCORE	E4, E6, E7, E8, F6, F7, F8, L9, L10, L11, M9, M10, M11
DGND	A1, G1, G6, G7, G8, G9, G10, G11, H6, H7, H8, H9, H10, H11, J1, J6, J7, J8, J9, J10, J11, K6, K7, K8, K9, K10, K11, N9, N10, N11, T1, T8
PADATA[15:0]	N5, D6, R4, C6, T3, B6, R3, D7, N4, C7, P4, T2, A7, N3, P3, B7
PBDATA[15:0]	D9, N7, B9, C9, B10, T5, A10, P6, P7, C10, P5, R7, T6, R6, R9, D10
PCDATA[15:0]	C5, N1, D5, A5, N2, B5, D4, M4, K5, M3, L5, L3, L2, M2, M1, L4
D[15:0]	J3, F5, G4, H1, H3, G5, J2, B1, G2, G3, H4, H2, A3, F2, A2, F3
A[7:0]	K3, J5, K4, L1, K2, K1, H5, J4

TYPICAL PERFORMANCE CHARACTERISTICS

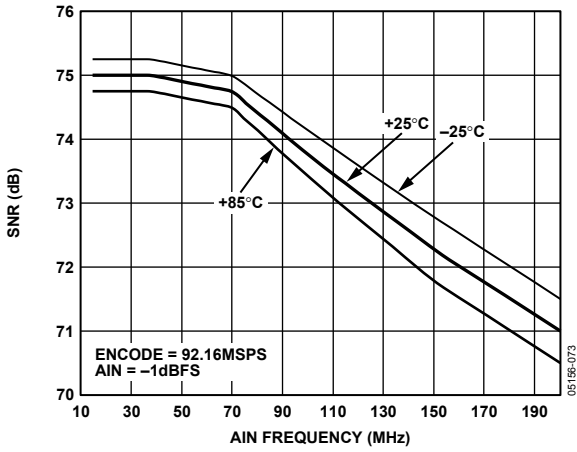

Figure 19. ADC Noise vs. Analog Frequency (46.08 MHz BW)

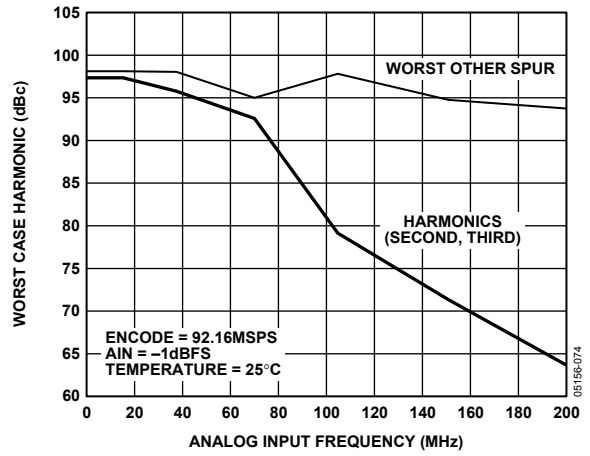

Figure 22. Harmonics vs. Analog Frequency (1F)

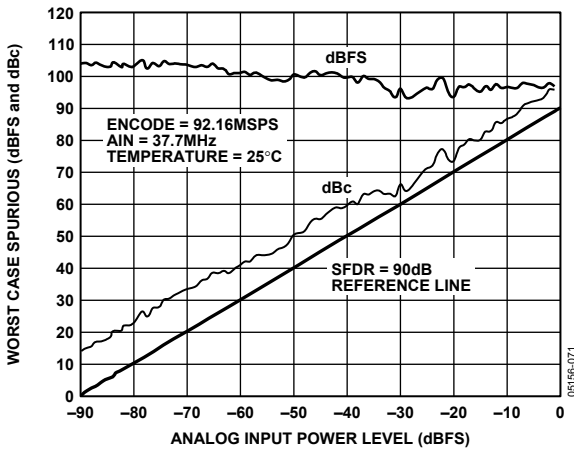

Figure 20. Single Tone SFDR at 37.7 MHz

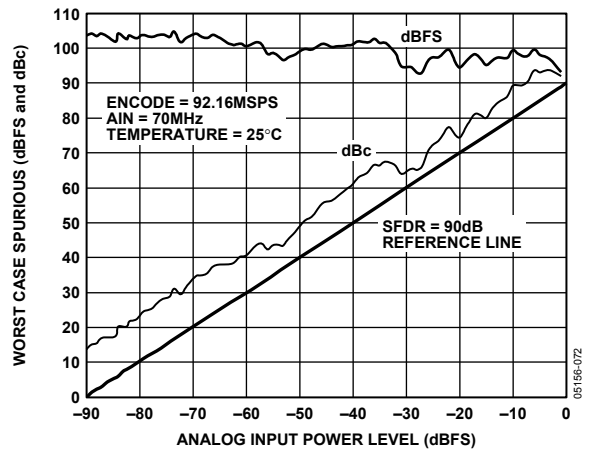

Figure 23. Single Tone SFDR at 70 MHz

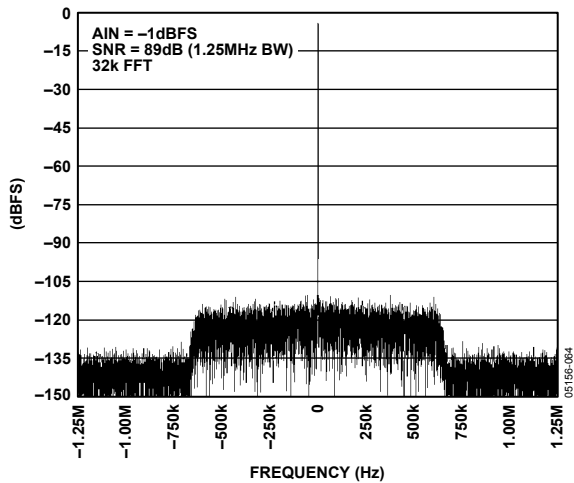

Figure 21. CDMA Single Tone AIN = 70 MHz; ENC = 92.16 MSPS

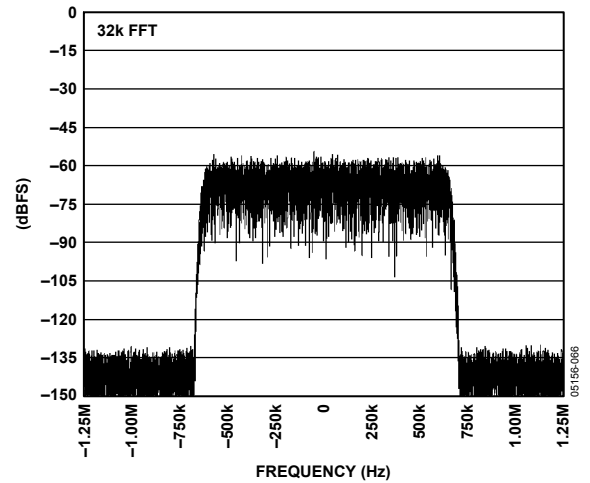

Figure 24. CDMA Carrier AIN = 70 MHz; ENC = 92.16 MSPS

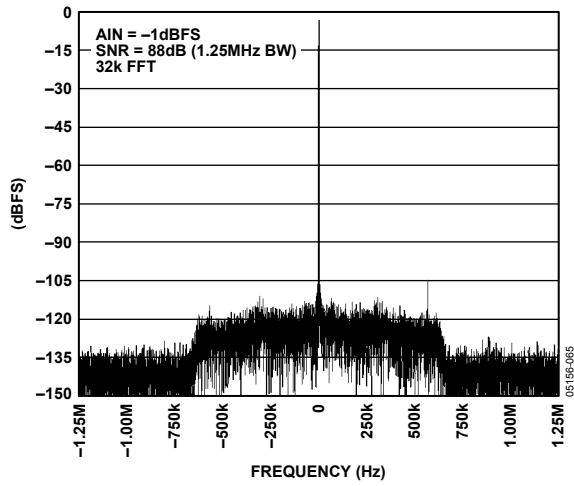

Figure 25. CDMA Single Tone AIN = 151.5 MHz; ENC = 92.16 MSPS

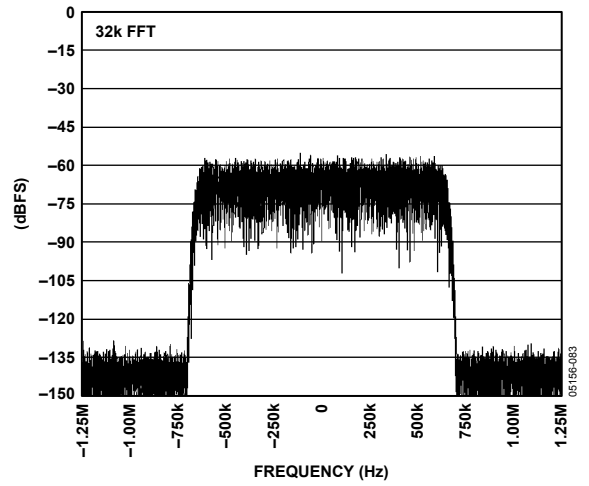

Figure 28. CDMA Carrier AIN = 151.5 MHz; ENC = 92.16 MSPS

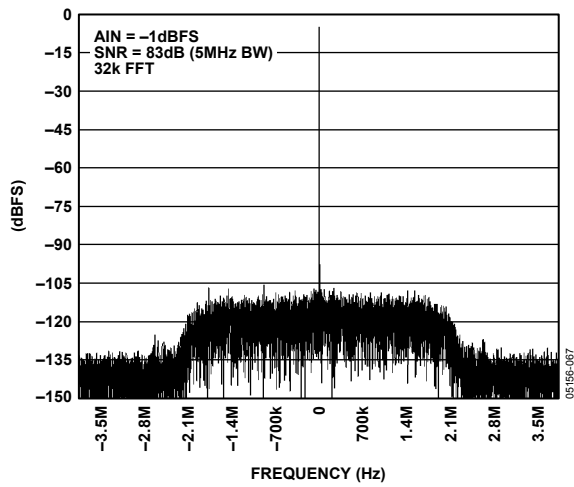

Figure 26. WCDMA Single Tone AIN = 70 MHz; Encode = 92.16 MSPS

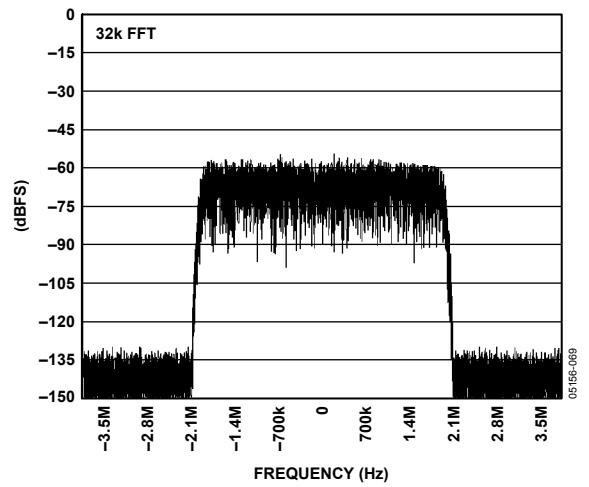

Figure 29. WCDMA Carrier AIN = 70 MHz; Encode = 92.16 MSPS

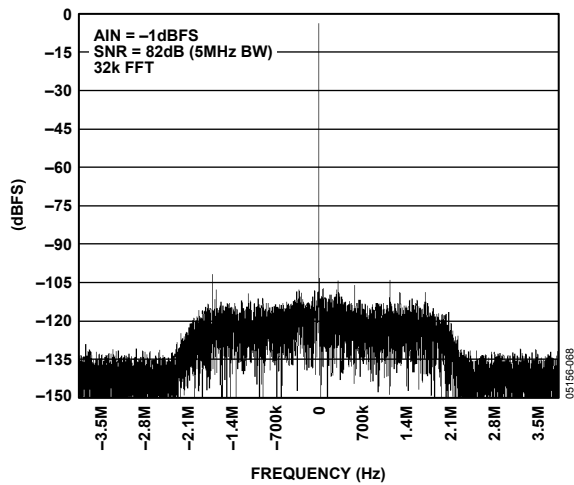

Figure 27. WCDMA Single Tone AIN = 151.5 MHz; Encode = 92.16 MSPS

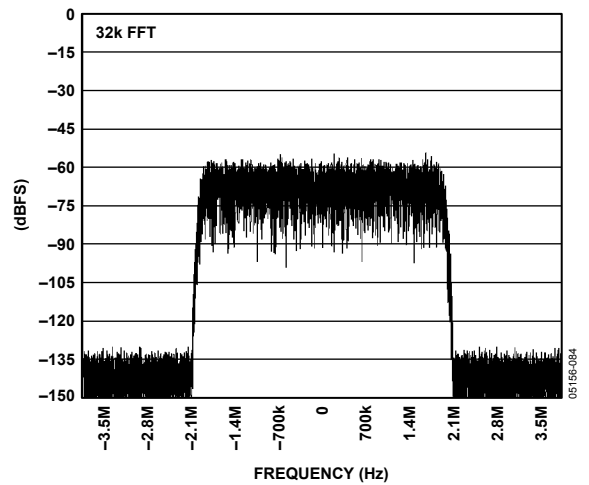

Figure 30. WCDMA Carrier AIN = 151.5 MHz; Encode = 92.16 MSPS

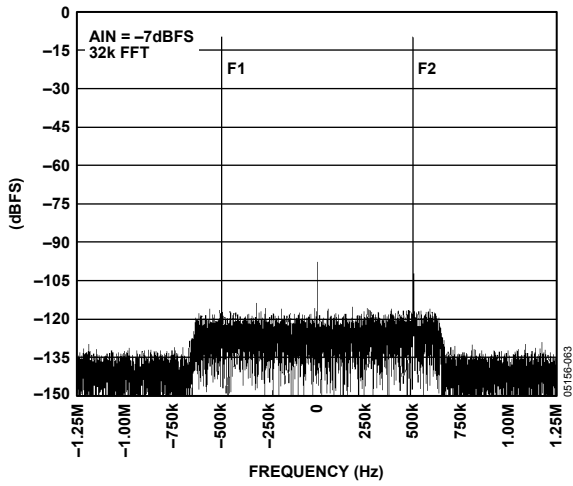

Figure 31. CDMA Two Tones at 55 MHz and 56 MHz; ENC = 92.16 MSPS

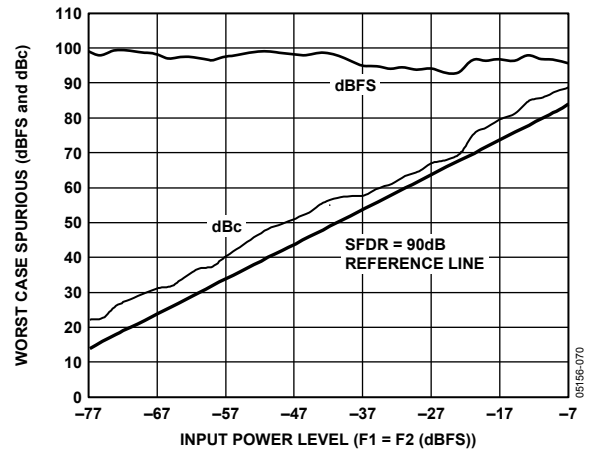

Figure 32. Two Tone SFDR at 55 MHz and 56 MHz

ADC EQUIVALENT CIRCUITS

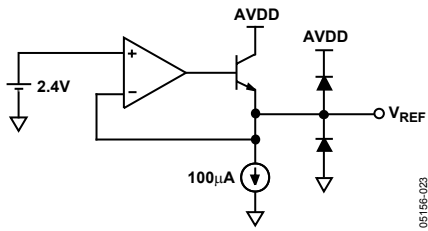

Figure 33. ADC 2.4 V Reference

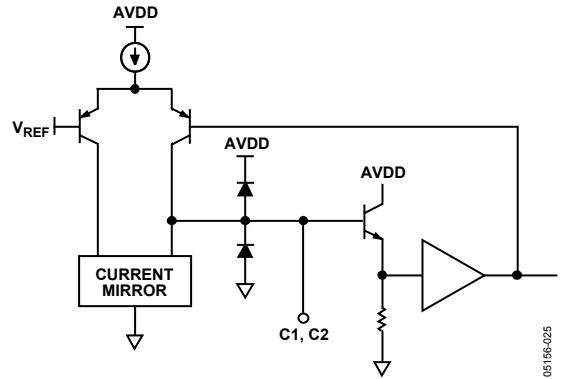

Figure 35. ADC Compensation Pins, C1 and C2

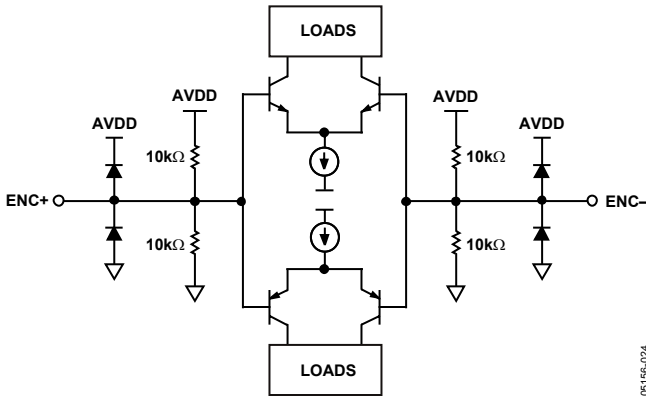

Figure 34. ADC Encode Inputs

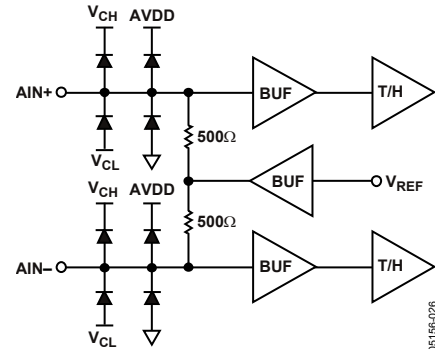

Figure 36. ADC Analog Input Stage

TERMINOLOGY

Analog Bandwidth

The analog input frequency at which the spectral power of the fundamental frequency (as determined by the FFT analysis) is reduced by 3 dB.

Differential Analog Input Resistance, Capacitance, and Impedance

The real and complex impedances measured at each analog input port. The resistance is measured statically, and the capacitance and differential input impedances are measured with a network analyzer.

Differential Analog Input Voltage Range

The peak-to-peak differential voltage that must be applied to the converter to generate a full-scale response. Peak differential voltage is computed by observing the voltage on a single pin and subtracting the voltage from the other pin, which is 180° out of phase. Peak-to-peak differential is computed by rotating the inputs phase 180° and taking the peak measurement again. Then the difference is computed between both peak measurements.

Encode Pulse Width/Duty Cycle

Pulse width high is the minimum amount of time that the ENCODE pulse should be left in Logic 1 state to achieve the rated performance. Pulse width low is the minimum time ENCODE pulse should be left in the low state. Several internal timing parameters are a function of t_{ENCL} and t_{ENCH} , optimum performance will be achieved with 50/50 duty cycle.

Harmonic Distortion, Second

The ratio of the rms signal amplitude to the rms value of the second harmonic component, reported in dBc.

Harmonic Distortion, Third

The ratio of the rms signal amplitude to the rms value of the third harmonic component, reported in dBc.

Full-Scale Input Power

Expressed in dBm. Computed using the following equation:

$$Power_{FULLSCALE} = 10 \log \left(\frac{V^2_{FULLSCALE_{RMS}}}{\frac{|Z|_{INPUT}}{0.001}} \right)$$

Minimum Conversion Rate

The encode rate at which the SNR of the lowest analog signal frequency drops by no more than 3 dB below the guaranteed limit.

Maximum Conversion Rate

Encode rate at which parametric testing is performed.

Noise for Any Range Within the ADC

$$V_{NOISE} = \sqrt{|Z|} \times 10^{\left(\frac{FS_{dBm} - SNR_{dBc} - SIGNAL_{dBFS}}{10} \right)}$$

where Z is the input impedance, FS is the full scale of the device for the frequency in question, SNR is the value for the particular input level, and $SIGNAL$ is the signal level within the ADC reported in dB below full scale. This value includes both thermal and quantization noise.

Power-Supply Rejection Ratio

The ratio of a change in input offset voltage to a change in power-supply voltage.

Power-Supply Rise Time

The time from when the dc supply is initiated until the supply output reaches the minimum specified operating voltage for the AD6654, measured at the supply pin(s) of the AD6654.

Processing Gain

When the tuned channel occupies less bandwidth than the input signal, this rejection of out-of-band noise is referred to as processing gain. By using large decimation factors, processing gain can improve the SNR of the ADC by 15 dB or more. Use the following equation to estimate processing gain:

$$Processing_Gain = 10 \log \left[\frac{Sample_Rate / 2}{Filter_Bandwidth} \right]$$

Signal-to-Noise Ratio (Without Harmonics)

The ratio of the rms signal amplitude (set at 1 dB below full scale) to the rms value of the sum of all other spectral components, excluding the first five harmonics and dc.

Spurious-Free Dynamic Range (SFDR)

The ratio of the rms signal amplitude to the rms value of the peak spurious spectral component. The peak spurious component might, or might not be, a harmonic. SFDR can be reported in dBc (degrades as signal level is lowered), or dBFS (always related back to converter full scale).

Two-Tone Intermodulation Distortion Rejection

The ratio of the rms value of either input tone to the rms value of the worst third-order intermodulation product, in dBc.

Two-Tone SFDR

Ratio of the rms value of either input tone to the rms value of the peak spurious component. The peak spurious component might, or might not be, an IMD product. SFDR can be reported in dBc (degrades as signal level is lowered), or in dBFS (always related back to converter full scale).

Worst Other Spur

Ratio of the rms signal amplitude to the rms value of the worst spurious component (excluding the second and third harmonic) reported in dBc.

THEORY OF OPERATION

ADC ARCHITECTURE

The AD6654 analog-to-digital converter (ADC) front end employs a 3-stage subrange architecture. This design approach achieves the required accuracy and speed, while maintaining low power consumption.

The AD6654 front end has complementary analog input pins, AIN+ and AIN-, as shown in Figure 1. Each analog input is centered at 2.4 V and should swing ± 0.55 V around this reference (see Figure 36). Because AIN+ and AIN- are 180° out of phase, the differential full-scale analog input signal is 2.2 V p-p.

Both analog inputs are buffered prior to the first track-and-hold, TH1. The high state of the ENCODE pulse places TH1 in hold mode. The held value of TH1 is applied to the input of a 5-bit coarse ADC1. The digital output of ADC1 drives a 5-bit digital-to-analog converter, DAC1. DAC1 requires 14 bits of precision that is achieved through laser trimming.

The output of DAC1 is subtracted from the delayed analog signal at the input of TH3 to generate a first residue signal. TH2 provides an analog pipeline delay to compensate for the digital delay of ADC1.

The first residue signal is applied to a second conversion stage consisting of a 5-bit ADC2, 5-bit DAC2, and pipeline TH4. The second DAC requires 10 bits of precision, which is met by the process with no trim. The input to TH5 is a second residue signal generated by subtracting the quantized output of DAC2 from the first residue signal held by TH4. TH5 drives a final 6-bit ADC3.

The digital outputs from ADC1, ADC2, and ADC3 are added together and corrected in the digital error correction logic to generate the final output data. The latency of the ADC core is four CLK cycles. The resulting 14-bit ADC data is internally routed directly to the integrated DDC for processing by the 4/6 independent DDC channels.

APPLICATION INFORMATION

ADC CONFIGURATION NOTES

Encoding the AD6654 ADC

The AD6654 encode signal must be a high quality, extremely low phase noise source to prevent degradation of performance. Maintaining 14-bit accuracy places a premium on encode clock phase noise. SNR performance can easily degrade by 3 dB to 4 dB with 70 MHz analog input signals when using a high jitter clock source. See the [AN-501, Aperture Uncertainty and ADC System Performance Application Note](#), for details.

For optimum performance, the AD6654 ADC front end must be clocked differentially. The encode signals are usually ac-coupled into the ENC+ and ENC– pins via a transformer or capacitors. The ENCODE pins are biased internally and require no additional bias.

Figure 37 shows one preferred method for clocking the AD6654. The clock source (low jitter) is converted from single-ended to differential using an RF transformer. The back-to-back Schottky diodes across the secondary of the transformer limit clock excursions into the AD6654 to approximately 0.8 V p-p differential. This helps prevent the large voltage swings of the clock from feeding through to other portions of the AD6654, and limits the noise presented to the encode inputs.

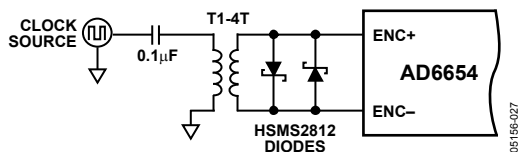

Figure 37. Crystal Clock Oscillator-Differential Encode

If a low jitter clock is available, another option is to ac-couple a differential ECL/PECL signal to the encode input pins as shown in Figure 38. A device that offers excellent jitter performance is the MC100EL16 (or same family) from ON Semiconductor®.

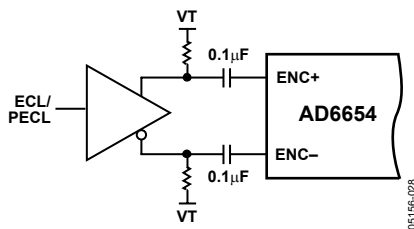

Figure 38. Differential ECL for Encode

Driving the Analog Inputs

As with most high speed, high dynamic range ADCs, the analog input to the AD6654 front end is differential. Differential inputs improve on-chip performance, because signals are processed through attenuation and gain stages. Most of the improvement is a result of differential analog stages having high rejection of even-order harmonics.

There are also benefits at the PCB level. First, differential inputs have high common-mode rejection to stray signals such as ground and power noise. Second, they provide good rejection to common-mode signals such as local oscillator feed-through.

The AD6654 analog input pins, AIN+ and AIN–, are centered at 2.4 V, and the signal at each input should swing ± 0.55 V around this voltage. Because AIN+ and AIN– are 180° out of phase, the full-scale differential analog input signal is 2.2 V p-p.

Each analog input connects through a 500 Ω resistor to the 2.4 V bias voltage and to the input of a differential buffer, as shown in Figure 36. The resistor network on the input properly biases the followers for maximum linearity and range. Therefore, the analog source driving the AD6654 should be ac-coupled to the input pins. Because the differential input impedance of the AD6654 is 1 k Ω , the analog input power requirement is only –2 dBm, simplifying the driver amplifier in many cases. To take full advantage of this high input impedance, a 20:1 transformer is required. This is a large ratio that could result in unsatisfactory performance. In this case, a lower step-up ratio could be used. The recommended method for driving the analog input of the AD6654 is to use a 4:1 impedance ratio RF transformer.

For example, if R_T is set to 60.4 Ω and R_S is set to 25 Ω , along with a 4:1 impedance ratio transformer, the input matches to a 50 Ω source with a full-scale drive of 4.8 dBm. Series resistors (R_S) on the secondary side of the transformer should be used to isolate the transformer from A/D. This limits the amount of dynamic current from the A/D flowing back into the secondary of the transformer. The 50 Ω impedance matching can also be incorporated on the secondary side of the transformer, as shown in the evaluation board schematic.

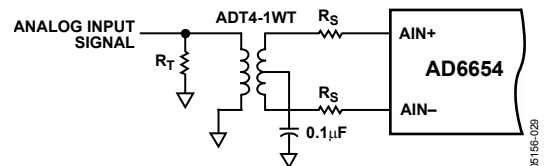

Figure 39. Transformer-Coupled Analog Input Circuit

In applications where dc-coupling, or additional gain is required, use a differential output op amp from Analog Devices, Inc., such as [AD8351](#), to drive the AD6654 (Figure 40). The [AD8351](#) op amp can be driven differentially, or configured to provide single-ended-to-differential conversion.

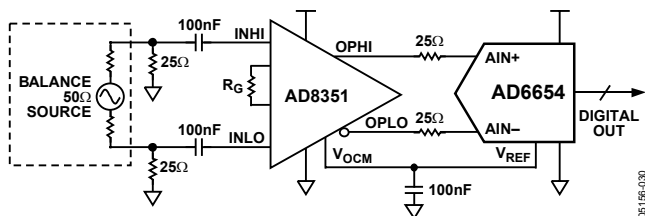

Figure 40. ADC Driving Application Using Differential Input

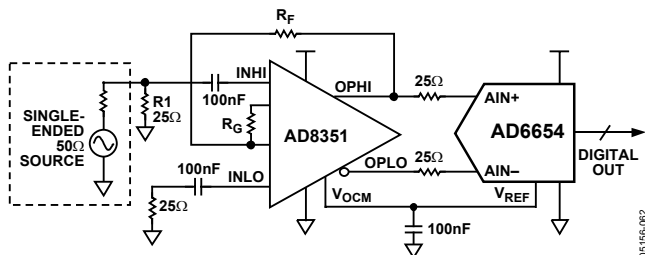

Figure 41. ADC Driving Application Using Single-Ended Input

DDC CONFIGURATION NOTES

PLL Clock Multiplier

In the AD6654, the input clock rate must be the same as the input data rate. In a typical digital down-converter architecture, the clock rate is a limitation on the number of filter taps that can be calculated in the programmable RAM coefficient filters (MRCF, DRCF, and CRCF). For slower ADC clock rates (or for any clock rate), this limitation can be overcome by using a PLL clock multiplier to provide a higher clock rate to the RCF filters. Using this clock multiplier, the internal signal processing clock rate can be increased up to 200 MHz. The CLK signal is used as an input to the PLL clock multiplier.

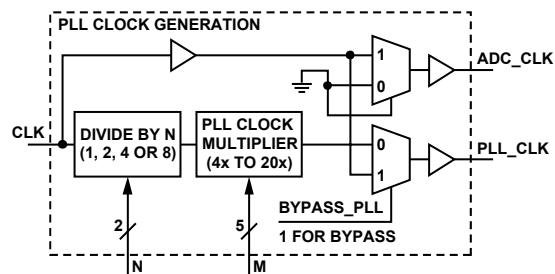

Figure 42. PLL Clock Generation

The PLL clock multiplier is programmable and uses the input clock rates between 30 MHz and 92.16 MHz to give a system clock rate (output) of as high as 200 MHz.

The output clock rate is given by

$$PLL_CLK = \frac{CLK \times M}{N}$$

where:

CLK is the input port clock rate.

M is a 5-bit programmable multiplication factor.

N is a predivide factor and can be 1, 2, 4, or 8.
M is a 5-bit number between 4 and 20 (inclusive).

The multiplication factor, M, is programmed using a 5-bit PLL clock multiplier word in the ADC clock control register. A value outside the valid range of 4 to 20 bypasses the PLL clock multiplier and, therefore, the PLL clock is the same as the input clock. The predivide factor, N, is programmed using a 2-bit ADC pre-PLL clock divider word in the ADC clock control register, as listed in Table 13.

Table 13. PLL Clock Generation Predivider Control

Predivide Word [1:0]	Divide-By Value for the Clock
00	Divide-by-1, bypass
01	Divide-by-2
10	Divide-by-4
11	Divide-by-8

For best signal processing advantage, the user should program the clock multiplier to give a system clock output as close as possible to, but not exceeding, 200 MHz. The internal blocks of the AD6654 that run off the PLL clock are rated to run at a maximum of 200 MHz. The default power-up state for the PLL clock multiplier is the bypass state, where CLK is passed on as the PLL clock.

ADC Gain Control

The DDC input port has individual, high speed gain control logic circuitry. Such gain control circuitry is useful in applications that involve large dynamic-range inputs. The AD6654 gain control logic allows programmable upper and lower thresholds and a programmable dwell-time counter for temporal hysteresis.

The DDC input port has a 3-bit output from the gain control block. The operation is controlled by the gain control enable bit in the gain control register of the DDC input port. Logic 1 in this bit programs the EXP[2:0] pins as gain control outputs.

Function

The gain control block features a programmable upper threshold register and a lower threshold register. The ADC input data is compared to both these registers. If ADC input data is larger than the upper threshold register, then the gain control output is decremented by 1. If the ADC input data is smaller than the lower threshold register, then the gain control output is incremented by 1.

When decrementing the gain control output, the change is immediate. But when incrementing the output, a dwell-time register is used to delay the change. If the ADC input is larger than the upper threshold register value, the gain control output is immediately decremented to prevent overflow.

When the ADC input is lower than the lower threshold register, a dwell timer is loaded with the value in the programmable 20-bit dwell-time register. The counter decrements once every

input clock cycle, as long as the input signal remains below the lower threshold register value. If the counter reaches 1, the gain control output is incremented by 1. If the signal goes above the lower threshold register value, the gain adjustment is not made, and the normal comparison to lower and upper threshold registers is initiated once again. Therefore, the dwell timer provides temporal hysteresis and prevents the gain from continuously switching.

In a typical application, if the ADC signal goes below the lower threshold for a time greater than the dwell time, then the gain control output is incremented by 1. Gain control bits control the gain ranging block, which appears before the ADC in the signal chain. With each increment of the gain control output, gain in the gain-ranging block is increased by 6.02 dB. This increases the dynamic range of the input signal into the ADC by 6.02 dB. This gain is compensated for in the AD6654 by relinearizing, as explained in the Relinearization section. Therefore, the AD6654 can increase the dynamic range of the ADC by 42 dB, provided that the gain-ranging block can support it.

Relinearization

The gain in the gain-ranging block (external) is compensated for by relinearizing, using the exponent bits EXP[2:0] of the input port. For this purpose, the gain control bits are connected to the EXP[2:0] bits, providing an attenuation of 6.02 dB for every increase in the gain control output. After the gain in the external gain-ranging block and the attenuation in the AD6654 (using EXP bits), the signal gain is essentially unchanged. The only change is the increase in the dynamic range of the ADC.

External gain-ranging blocks have a delay associated with changing the gain of the signal. Typically, these delays can be up to 14 clock cycles. The gain change in the AD6654 (via EXP[2:0]) must be synchronized with the gain change in the gain-ranging block (external). This is allowed in the AD6654 by providing a flexible delay, programmable 6-bit word in the gain control register. The value in this 6-bit word gives the delay in input clock cycles. A programmable pipeline delay given by the 6-bit value (maximum delay of 63 clock cycles) is placed between the gain control output and the EXP[2:0] input. Therefore, the external gain-ranging block's settling delays are compensated for in the AD6654.

Note that any gain changes that are initiated during the relinearization period are ignored. For example, if the AD6654 detects that a gain adjustment is required during the relinearization period of a previous gain adjustment, then the new adjustment is ignored.

Setting Up the Gain Control Block

To set up the gain control block for the input port, the individual upper threshold registers and lower threshold registers should be written with appropriate values. The 10-bit values written into upper and lower threshold registers are compared to the 10 MSBs of the absolute magnitude calculated using the input port data. The 20-bit dwell-time register should have the appropriate number of clock cycles to provide temporal hysteresis.

A 6-bit relinearization pipeline delay word is set to synchronize with the settling delay in the external gain-ranging circuitry. Finally, the gain control enable bit is written with Logic 1 to activate the gain control block. On enabling, the gain control output bits are made 000 (output on EXP[2:0] pins), which represent the minimum gain for the external gain-ranging circuitry and corresponding minimum attenuation during relinearization. The normal functioning takes over, as explained previously in this section.

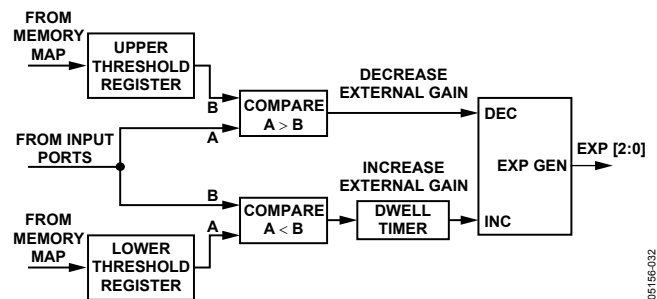

Figure 43. Gain Control Block Diagram

05156-032

ADC INPUT PORT MONITOR FUNCTION

The AD6654 provides a power monitor function that can monitor the DDC input stream and gather statistics about the received signal in a signal chain. This function block can operate in one of three modes measuring the following over a programmable period of time:

- Peak power
- Mean power
- Number of samples crossing a threshold

These functions are controlled via the 2-bit power monitor function select bits in the power monitor control register of the DDC input port. The DDC input port can be set for different modes, but only one function can be active at a time. The three modes of operation can function continuously over a programmable time period. This time period is programmed as the number of input clock cycles in a 24-bit ADC monitor period register (AMPR). An internal magnitude storage register (MSR) is used to monitor, accumulate, or count, depending on the mode of operation.

PEAK DETECTOR MODE

Control Bits 00

The magnitude of the input port signal is monitored over a programmable time period (given by AMPR) to give the peak value detected. This mode is set by programming Logic 0 in the power monitor function select bits in the power monitor control register of the DDC input port. The 24-bit AMPR must be programmed before activating this mode.

After enabling this mode, the value in the AMPR is loaded into a monitor period timer and the countdown is started. The magnitude of the input signal is compared to the MSR, and the greater of the two is updated back into the MSR. The initial value of the MSR is set to the current ADC input signal magnitude. This comparison continues until the monitor period timer reaches a count of 1.

When the monitor period timer reaches a count of 1, the value in the MSR is transferred to the power monitor holding register, which can be read through the microport or the serial port. The monitor period timer is reloaded with the value in the AMPR, and the countdown is started. Also, the magnitude of the first input sample is updated in the MSR, and the comparison and update procedure, as explained above, continues. If the interrupt is enabled, an interrupt is generated, and the interrupt status register is updated when the AMPR reaches a count of 1.

Figure 44 is a block diagram of the peak detector logic. The MSR contains the absolute magnitude of the peak detected by the peak detector logic.

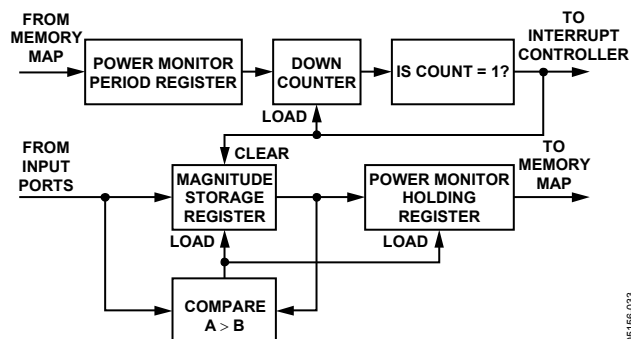

Figure 44. ADC Input Peak Detector Block Diagram

MEAN POWER MODE

Control Bits 01

In this mode, the magnitude of the input port signal is integrated (by adding an accumulator) over a programmable time period (given by AMPR) to give the integrated magnitude of the input signal. This mode is set by programming Logic 1 in the power monitor function select bits in the power monitor control register of the DDC input port. The 24-bit AMPR, representing the period over which integration is performed, must be programmed before activating this mode.

After enabling this mode, the value in the AMPR is loaded into a monitor period timer, and the countdown is immediately started. The 15-bit magnitude of input signal is right-shifted by nine bits to give 6-bit data. This 6-bit data is added to the contents of a 24-bit holding register, thereby performing an accumulation. The integration continues until the monitor period timer reaches a count of 1.

When the monitor period timer reaches a count of 1, the value in the MSR is transferred to the power monitor holding register (after some formatting), which can be read through the microport or the serial port. The monitor period timer is reloaded with the value in the AMPR, and the countdown is started. Also, the first input sample signal magnitude is updated in the MSR, and the accumulation continues with the subsequent input samples. If the interrupt is enabled, an interrupt is generated, and the interrupt status register is updated when the AMPR reaches a count of 1. Figure 45 illustrates the mean power monitoring logic.

The value in the MSR is a floating-point number with 4 MSBs and 20 LSBs. If the 4 MSBs are EXP and the 20 LSBs are MAG, the value in dBFS can be decoded using the following equation:

$$\text{MeanPower} = 10 \log \left[\left(\frac{\text{MAG}}{2^{20}} \right) 2^{-(\text{EXP}-1)} \right]$$

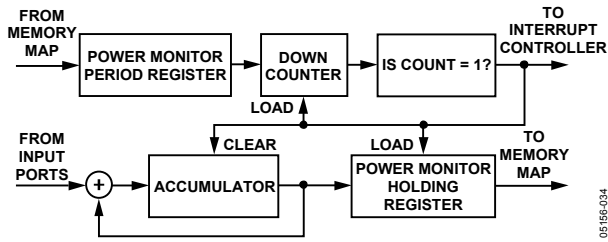

Figure 45. ADC Input Mean Power Monitoring Block Diagram

THRESHOLD CROSSING MODE

Control Bits 10

In this mode of operation, the magnitude of the input port signal is monitored over a programmable time period (given by AMPR) to count the number of times it crosses a certain programmable threshold value. This mode is set by programming Logic 1x (where x is a don't care bit) in the power monitor function select bits in the power monitor control register of the DDC input port. Before activating this mode, the user needs to program the 24-bit AMPR and the 10-bit upper threshold register of the DDC input port. The same upper threshold register is used for both power monitoring and gain control (see the ADC Gain Control section).

After entering this mode, the value in the AMPR is loaded into a monitor period timer, and the countdown is started. The magnitude of the input signal is compared to the upper threshold register (programmed previously) on each input clock cycle. If the input signal has a magnitude greater than the upper threshold register, then the MSR register is incremented by 1. The initial value of the MSR is set to 0. This comparison and incrementing of the MSR register continues until the monitor period timer reaches a count of 1.

When the monitor period timer reaches a count of 1, the value in the MSR is transferred to the power monitor holding register, which can be read through the microport or the serial port. The monitor period timer is reloaded with the value in the AMPR, and the countdown is started. The MSR register is also cleared to a value of 0. If interrupts are enabled, an interrupt is generated, and the interrupt status register is updated when the AMPR reaches a count of 1. Figure 46 illustrates the threshold crossing logic. The value in the MSR is the number of samples that have an amplitude greater than the threshold register.

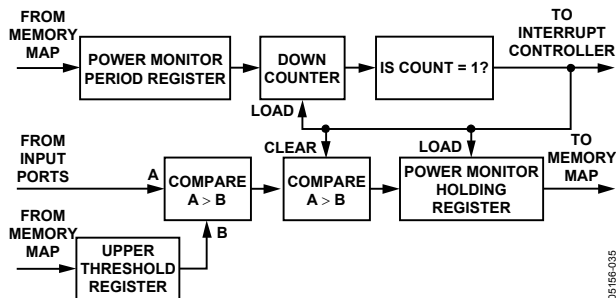

Figure 46. ADC Input Threshold Crossing Block Diagram

ADDITIONAL CONTROL BITS

For additional flexibility in the power monitoring process, two control bits are provided in the power monitor control register. The two control bits are the disable monitor period timer bit and the clear-on-read bit. These options have the same function in all three modes of operation.

Disable Monitor Period Timer Bit

When the disable monitor period timer bit is written with Logic 1, the timer continues to run but does not cause the contents of the MSR to be transferred to the holding register when the count reaches 1. This function of transferring the MSR to the power monitor holding register and resetting the MSR is now controlled by a read operation on the microport or serial port.

When a microport or serial port read is performed on the power monitor holding register, the MSR value is transferred to the holding register. After the read operation, the timer is reloaded with the AMPR value. If the timer reaches 1 before the microport or serial port read, the MSR value is not transferred to the holding register, as in normal operation. The timer still generates an interrupt on the AD6654 interrupt pin and updates the interrupt status register. An interrupt appears on the IRP pin, if interrupts are enabled in the interrupt enable register.

Clear-on-Read Bit

This control bit is valid only when the disable monitor period timer bit is Logic 1. When both of these bits are set, a read operation to either the microport or the serial port reads the MSR value, and the monitor period timer is reloaded with the AMPR value. The MSR is cleared (written with current input signal magnitude in peak power and mean power modes; written with a 0 in threshold crossing mode), and normal operation continues.

When the monitor period timer is disabled and the clear-on-read bit is set, a read operation to the power monitor holding register clears the contents of the MSR and, therefore, the power monitor loop restarts.

If the clear-on-read bit is Logic 0, the read operation to the microport or serial port does not clear the MSR value after it is transferred into the holding register. The value from the previous monitor time period persists, and it continues to be compared, accumulated, or incremented, based on new input signal magnitude values.

INPUT CROSSBAR MATRIX

The AD6654 has one ADC input port and six channels. Each channel can individually select its input source from either the real ADC input port, or from an internally generated pseudo random sequence (referred to as a PN sequence) generator. Each channel has an input crossbar matrix to facilitate selection of the input signal source.

The selection of input signal for a particular channel is made using a 4-bit cross bar mux select word in the ADC input control register.

Each channel has a separate selection for individual control. Cross bar mux selection enables each channel to select its input signal source.

Table 14 gives the valid combinations of cross bar mux select values and the corresponding input signal selections.

Table 14. Cross Bar Mux Selection Bits

Cross Bar Mux Select Bits	Input Signal Selection
0010	ADC input drives the channel.
0100	Internal PN sequence drives the channel.

NUMERICALLY CONTROLLED OSCILLATOR (NCO)

Each channel consists of an independent complex NCO and a complex mixer. This processing stage is comprised of a digital tuner consisting of three multipliers and a 32-bit complex NCO. The NCO serves as a quadrature local oscillator capable of producing an NCO frequency of between $-\text{CLK}/2$ and $+\text{CLK}/2$ with a resolution of $\text{CLK}/232$ in the complex mode, where CLK is the input clock frequency.

The frequency word used for generating the NCO is a 32-bit word. This word is used to generate a 20-bit phase word. A 16-bit phase offset word is added to this phase word. 18 bits of this phase word are used to generate the sine and cosine of the required NCO frequency. The amplitude of the sine and cosine are represented using 17 bits. The worst-case spurious signal from the NCO is better than -100 dBc for all output frequencies.

Because all the filtering in the AD6654 is low-pass filtering, the carrier of interest is tuned down to dc (frequency = 0 Hz). This is illustrated in Figure 47. Once the signal of interest is tuned down to dc, the unwanted adjacent carriers can be rejected using the low-pass filtering that follows.

NCO FREQUENCY

The NCO frequency value is given by the 32-bit two's complement number entered in the NCO frequency register. Frequencies between $-\text{CLK}/2$ and $+\text{CLK}/2$ (with $+\text{CLK}/2$ excluded) are represented using this frequency word:

0x8000 0000 represents a frequency given by $-\text{CLK}/2$.
 0x0000 0000 represents dc (frequency is 0 Hz).
 0x7FFF FFFF represents $\text{CLK}/2 - \text{CLK}/2^{32}$.

The NCO frequency word can be calculated using following the equation:

$$\text{NCO_FREQ} = 2^{32} \frac{\text{mod}(f_{CH}, f_{CLK})}{f_{CLK}}$$

where:

NCO_FREQ is the 32-bit two's complement number representing the NCO frequency register.

f_{CH} is the desired carrier frequency.

f_{CLK} is the clock rate for the channel under consideration.

$\text{mod}()$ is a remainder function. For example, $\text{mod}(110, 100) = 10$ and, for negative numbers, $\text{mod}(-32, 10) = -2$.

Note that this equation applies to the aliasing of signals in the digital domain (that is, aliasing introduced when digitizing analog signals).

For example, if the carrier frequency is 100 MHz and the clock frequency is 80 MHz,

$$\frac{\text{mod}(f_{CH}, f_{DK})}{f_{CLK}} = \frac{20}{80} = 0.25$$

This, in turn, converts to 0x4000 0000 in the 32-bit two's complement representation for NCO_FREQ .

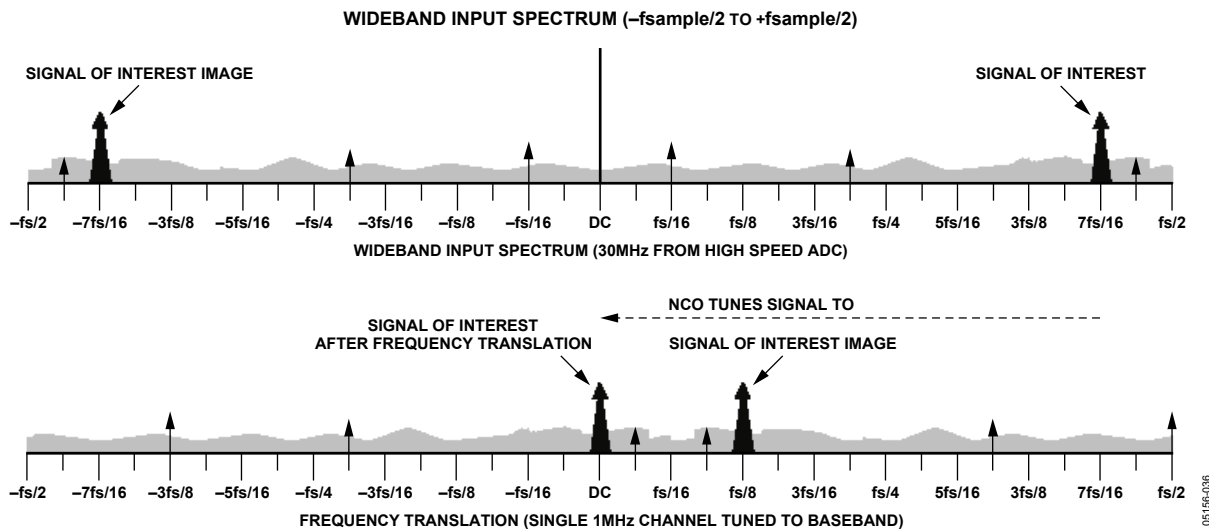

Figure 47. Frequency Translation Principle Using the NCO and Mixer

If the carrier frequency is 70 MHz and the clock frequency is 80 MHz, then:

$$\frac{\text{mod}(f_{CH}, f_{CLK})}{f_{CLK}} = \frac{10}{80} = 0.125$$

This, in turn, converts to 0xE000 0000 in the twos complement 32-bit representation.

MIXER

The NCO is accompanied by a mixer. Its operation is similar to an analog mixer. It performs the down-conversion of real input signals by using the NCO frequency as a local oscillator. This mixer performs a real mixer operation (with two multipliers). The mixer adjusts its operation based on the input signal provided to each individual channel.

BYPASS

The NCO and the mixer can be individually bypassed in each channel by writing Logic 1 in the NCO bypass bit in the NCO control register of the channel under consideration.

CLEAR PHASE ACCUMULATOR ON HOP

When clear, the NCO accumulator bit of the NCO control register is set (Logic 1), the NCO phase accumulator is cleared prior to a frequency hop. Refer to the Chip Synchronization section for details on frequency hopping. This ensures a consistent phase of the NCO on each hop. The NCO phase offset is unaffected by this setting and is still in effect. If phase-continuous hopping is needed, this bit should be cleared (NCO accumulator is not cleared). The last phase in the NCO phase register is the initiating point for the new frequency.

PHASE DITHER

The AD6654 provides a phase dither option for improving the spurious performance of the NCO. Writing Logic 1 in the phase dither enable bit of the NCO control register of individual channels enables phase dither. When phase dither is enabled, random phase is added to the LSBs of the phase accumulator of the NCO. When phase dither is enabled, spurs due to phase truncation in the NCO are randomized.

The energy from these spurs is spread into the noise floor and the spurious free dynamic range is increased at the expense of a very slight decrease in the SNR. The choice of whether to use phase dither in a system is ultimately decided by the system goals. If lower spurs are desired at the expense of a slightly raised noise floor, phase dither should be employed. If a low noise floor is desired and higher spurs can be tolerated or filtered by subsequent stages, then phase dither is not needed.

AMPLITUDE DITHER

Amplitude dither can be used to improve spurious performance of the NCO. Amplitude dither is enabled by writing Logic 1 in the amplitude dither enable bit of the NCO control register of the channel under consideration. Random amplitude is added to the LSBs of the sine and cosine amplitudes, when this feature is enabled. Amplitude dither improves performance by randomizing the amplitude quantization errors within the angular-to-Cartesian conversion of the NCO. This option might reduce spurs at the expense of a slightly raised noise floor. Amplitude dither and phase dither can be used together, separately, or not at all.

NCO FREQUENCY HOLD-OFF REGISTER

When the NCO frequency registers are written by the micro-port or serial port, data is passed to a shadow register. Data can be moved to the main registers when the channel comes out of sleep mode, or when a sync hop occurs. In either event, a counter can be loaded with the NCO frequency hold-off register value. The 16-bit unsigned integer counter starts counting down, clocked by the input port clock selected at the crossbar mux. When the counter reaches 0, the new frequency value in the shadow register is written to the NCO frequency register. Writing 1 in this hold-off register updates the NCO frequency register as soon as the start sync or hop sync occurs. See the Chip Synchronization section for details.

PHASE OFFSET

The phase offset register can be written with a value that is added as an offset to the phase accumulator of the NCO. This 16-bit register is interpreted as a 16-bit unsigned integer. A 0x0000 in this register corresponds to a 0 radian offset and a 0xFFFF corresponds to an offset of $2\pi \times (1 - 1/2^{16})$ radians. This register allows multiple NCOs (multiple channels) to be synchronized to produce complex sinusoids with a known and steady phase difference.

HOP SYNC

A hop sync should be issued to the channel, when the NCO frequency of that channel needs to be changed from one frequency to another. See the Chip Synchronization section for details.

FIFTH-ORDER CIC FILTER

The signal processing stage immediately after the NCO is a CIC filter stage. This stage implements a fixed coefficient, decimating, cascade integrated comb filter. The input rate to this filter is the same as the data rate at the input port; the output rate from this stage is dependent on the decimation factor.

$$f_{CIC} = \frac{f_{IN}}{M_{CIC}}$$

The decimation ratio, M_{CIC} , can be programmed from 2 to 32 (only integer values). The 5-bit word in the CIC decimation register is used to set the CIC decimation factor. A binary value of one less than the decimation factor is written into this register. The decimation ratio of 1 can be achieved by bypassing the CIC filter stage. The frequency response of the filter is given by the following equations. The gain and pass-band droop of the CIC should be calculated by these equations. Both parameters can be offset in the RCF stage.

$$H(z) = \frac{1}{2^{(S_{CIC}+5)}} \times \left(\frac{1-Z^{-M_{CIC}}}{1-Z^{-1}} \right)^5$$

$$H(f) = \frac{1}{2^{(S_{CIC}+5)}} \times \left(\frac{\text{SIN}\left(\frac{M_{CIC} \times f}{f_{IN}}\right)}{\text{SIN}\left(\pi \frac{f}{f_{IN}}\right)} \right)^5$$

where:

f_{IN} is the data input rate to the channel under consideration.
 S_{CIC} , the scale factor, is a programmable unsigned integer between 0 and 20.

The attenuation of the data into the CIC stage should be controlled in 6 dB increments. For the best dynamic range, S_{CIC} should be set to the smallest value possible (lowest attenuation possible) without creating an overflow condition. This can be accomplished safely using the following equation, where $input_level$ is the largest possible fraction of the full-scale value at the input port. This value is output from the NCO stage and pipelined into the CIC filter.

$$S_{CIC} = \text{ceil}(\log_2(M_{CIC}^5 \times input_level)) - 5$$

$$OL_{CIC} = \frac{(M_{CIC}^5)}{2^{S_{CIC}+5}} \times input_level$$

BYPASS

The fifth-order CIC filter can be bypassed when no decimation is required of it. When it is bypassed, the scaling operation is

not performed. In bypass mode, the output of the CIC filter is the same as the input of the CIC filter.

CIC REJECTION

Table 15 illustrates the amount of bandwidth as a percentage of the data rate into the CIC stage, which can be protected with various decimation rates and alias rejection specifications. The maximum input rate into the CIC is 150 MHz (the same as the maximum input port data rate). The data can be scaled to any other allowable sample rate.

Table 15 can be used to decide the minimum decimation required in the CIC stage to preserve a certain bandwidth. The CIC5 stage can protect a much wider bandwidth to any given rejection, when a decimation ratio lower than that identified in the table is used. The table helps to calculate an upper boundary on decimation, M_{CIC} , given the desired filter characteristics.

Table 15. SSB CIC5 Alias Rejection Table ($f_{IN} = 1$)

MCIC5	-60 dB	-70 dB	-80 dB	-90 dB	-100 dB
2	8.078	6.393	5.066	4.008	3.183
3	6.367	5.110	4.107	3.297	2.642
4	5.022	4.057	3.271	2.636	2.121
5	4.107	3.326	2.687	2.170	1.748
6	3.463	2.808	2.270	1.836	1.480
7	2.989	2.425	1.962	1.588	1.281
8	2.627	2.133	1.726	1.397	1.128
9	2.342	1.902	1.540	1.247	1.007
10	2.113	1.716	1.390	1.125	0.909
11	1.924	1.563	1.266	1.025	0.828
12	1.765	1.435	1.162	0.941	0.760
13	1.631	1.326	1.074	0.870	0.703
14	1.516	1.232	0.998	0.809	0.653
15	1.416	1.151	0.932	0.755	0.610
16	1.328	1.079	0.874	0.708	0.572
17	1.250	1.016	0.823	0.667	0.539
18	1.181	0.960	0.778	0.630	0.509
19	1.119	0.910	0.737	0.597	0.483
20	1.064	0.865	0.701	0.568	0.459
21	1.013	0.824	0.667	0.541	0.437
22	0.967	0.786	0.637	0.516	0.417
23	0.925	0.752	0.610	0.494	0.399
24	0.887	0.721	0.584	0.474	0.383
25	0.852	0.692	0.561	0.455	0.367
26	0.819	0.666	0.540	0.437	0.353
27	0.789	0.641	0.520	0.421	0.340
28	0.761	0.618	0.501	0.406	0.328
29	0.734	0.597	0.484	0.392	0.317
30	0.710	0.577	0.468	0.379	0.306
31	0.687	0.559	0.453	0.367	0.297
32	0.666	0.541	0.439	0.355	0.287

EXAMPLE CALCULATIONS

Goal: Implement a filter with an input sample rate of 100 MHz requiring 100 dB of alias rejection for a ± 1.4 MHz pass band.

Solution: First determine the percentage of the sample rate that is represented by the pass band.

$$BW_{FRACTION} = 100 \times \frac{1.4 \text{ MHz}}{100 \text{ MHz}} = 1.4$$

In the -100 dB column in Table 15, find the value greater than or equal to the pass-band percentage of the clock rate. Then find the corresponding rate decimation factor (M_{CIC}). For an M_{CIC} of 6, the frequency that has -100 dB of alias rejection is 1.48%, which is slightly larger than the 1.4% calculated. Therefore, for this example, the maximum bound on CIC decimation rate is 6. A higher M_{CIC} means less alias rejection than the 100 dB required.

FIR HALF-BAND BLOCK

The output of the CIC filter is pipelined into the FIR HB (half-band) block. Each channel has two sets of cascading fixed coefficient FIR and fixed coefficient half-band filters. The half-band filters decimate by 2. Each of these filters (FIR1, HB1, FIR2, and HB2) is described in the following sections.

3-TAP FIXED COEFFICIENT FILTER (FIR1)

The 3-tap FIR filter is useful in certain filter configurations in which extra alias protection is needed for the decimating HB1 filter. It is a simple sum-of-products FIR filter with three filter taps and 2-bit fixed coefficients. Note that this filter does not decimate. The coefficients of this symmetric filter are {1, 2, 1}. The normalized coefficients used in the implementation are {0.25, 0.5, 0.25}.

The user can either use or bypass this filter. Writing Logic 0 to the FIR1 enable bit in the FIR-HB control register bypasses this fixed coefficient filter. The filter is useful only in certain filter configurations and bypassing it for other applications results in power savings.

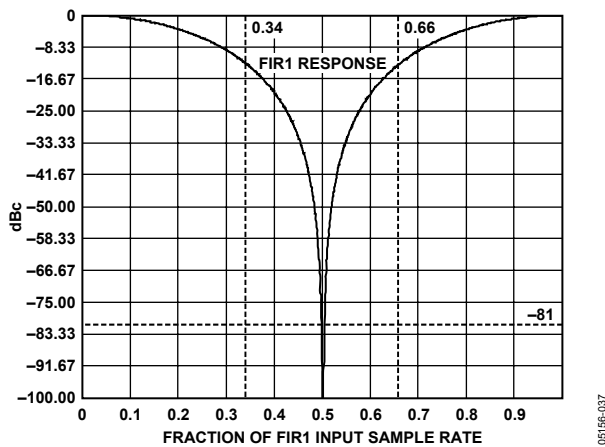

Figure 48. FIR1 Filter Response to the Input Rate of the Filter

This filter runs at the same sample rate as the CIC filter output rate and is given by

$$f_{FIR1} = \frac{f_{IN}}{M_{CIC}}$$

where:

f_{IN} is the input rate to the channel.

M_{CIC} is the decimation ratio in the CIC filter stage.

The maximum input and output rates for this filter are 150 MHz.

DECIMATE-BY-2 HALF-BAND FILTER (HB1)

The next stage of the FIR-HB block is a decimate-by-2 half-band filter. The 11-tap, symmetrical, fixed coefficient HB1 filter has low power consumption due to its polyphase implementation. The filter has 22 bits of input and output data with 10-bit coefficients. Table 16 lists the coefficients of the half-band filter. The normalized coefficients used in the implementation and the 10-bit decimal equivalent value of the coefficients are also listed. Other coefficients are 0s.

Table 16. Fixed Coefficients for HB1 Filter

Coefficient Number	Normalized Coefficient	Decimal Coefficient (10-Bit)
C1, C11	0.013671875	7
C3, C9	-0.103515625	-53
C5, C7	0.58984375	302
C6	1	512

Similar to the FIR1 filter, this filter can be used or bypassed. Writing Logic 0 to the HB1 enable bit in the FIR-HB control register bypasses this fixed coefficient HB filter. The filter is useful only in certain filter configurations and bypassing it for other applications results in power savings. For example, it is useful in narrow-band and wideband output applications in which more filtering is required, as compared to very wide bandwidth applications in which a higher output rate might prohibit the use of a decimating filter. The response of the filter is shown in Figure 49.

The input sample rate of this filter is the same as the CIC filter output rate and is given by

$$f_{HB1} = \frac{f_{IN}}{M_{CIC}}$$

where:

f_{IN} is the input rate to the channel.

M_{CIC} is the decimation ratio in the CIC filter stage.

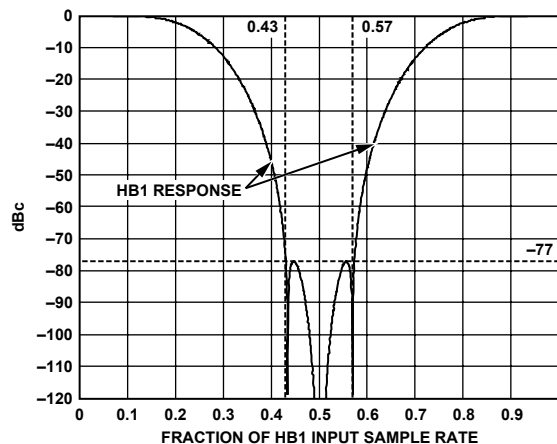

Figure 49. HB1 Filter Response to the Input Rate of the Filter

The filter has a maximum input sample rate of 150 MHz and, when filter is not bypassed, the maximum output rate is 75 MHz.

The filter has a ripple of 0.0012 dB and rejection of 77 dB. For an alias rejection of 77 dB, the alias-protected bandwidth is 14% of the filter input sample rate. The bandwidth of the filter for a ripple of 0.00075 dB is also the same as the alias-protected bandwidth, due to the nature of half-band filters. The 3 dB bandwidth of this filter is 44% of the filter input sample rate. For example, if the sample rate into the filter is 50 MHz, then the alias-protected bandwidth of the HB1 filter is 7 MHz. If the bandwidth of the required carrier is greater than 7 MHz, then HB1 might not be useful.

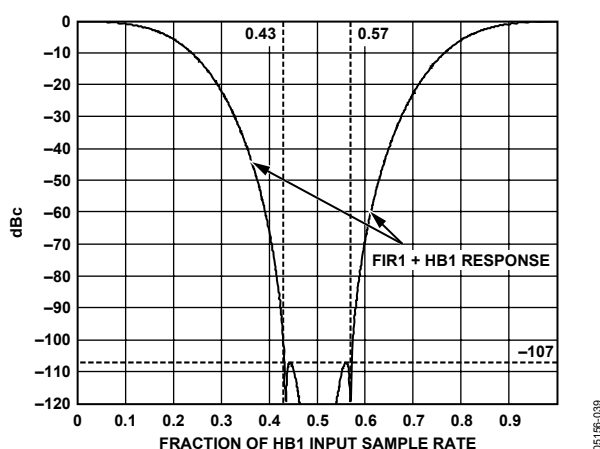

Figure 50. Composite Response of FIR1 and HB1 Filters to Their Input Rate

6-TAP FIXED COEFFICIENT FILTER (FIR2)

Following the first cascade of the FIR1 and HB1 filters is the second cascade of the FIR2 and HB2 filters. The 6-tap, fixed coefficient FIR2 filter is useful in providing extra alias protection for the decimating HB2 filter in certain filter configurations. It is a simple sum-of-products FIR filter with six filter taps and 5-bit fixed coefficients. Note that this filter does not decimate. The normalized coefficients used in the implementation and the 5-bit decimal equivalent value of the coefficients are listed in Table 17.

Table 17. 6-Tap FIR2 Filter Coefficients

Coefficient Number	Normalized Coefficient	Decimal Coefficient (5-Bit)
C0, C5	-0.125	-2
C1, C4	0.1875	3
C2, C3	0.9375	15

The user can either use or bypass this filter. Writing Logic 0 to FIR2 enable bit in the FIR-HB control register bypasses this fixed coefficient filter. The filter is useful only in certain filter configurations and bypassing it for other applications results in power savings. The filter is especially useful in increasing the stop-band attenuation of the HB2 filter that follows. Therefore, it is optimal to use both FIR2 and HB2 in a configuration.

This filter runs at a sample rate given by one of the following equations:

$$f_{FIR2} = f_{HB1}, \text{ if HB1 is bypassed}$$

$$f_{FIR2} = \frac{f_{HB1}}{2}, \text{ if HB1 is not bypassed}$$

where:

f_{HB1} is the input rate of the HB1 filter.

f_{FIR2} is the input rate of the FIR2 filter.

The maximum input and output rate for this filter is 75 MHz. The response of the FIR2 filter is shown in Figure 51.

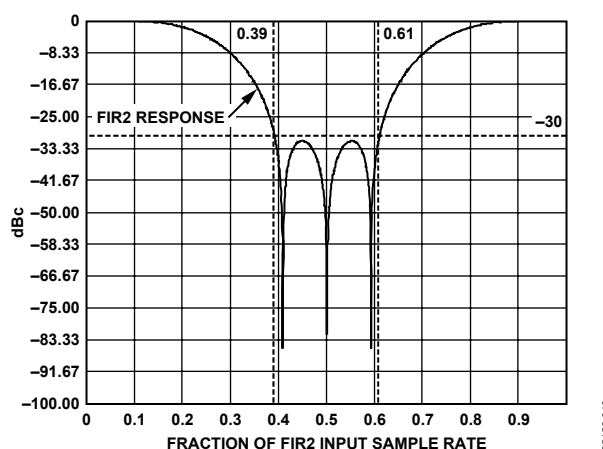

Figure 51. FIR2 Filter Response to the Input Rate of the Filter

DECIMATE-BY-2 HALF-BAND FILTER (HB2)

The second stage of the second cascade of the FIR-HB block is a decimate-by-2 half-band filter. The 27-tap, symmetric, fixed coefficient HB2 filter has low power consumption due to its polyphase implementation. The filter has 20 bits of input and output data with 12-bit coefficients. The normalized coefficients used in the implementation and the 10-bit decimal equivalent value of the coefficients are listed in Table 18. Other coefficients are 0s.

Table 18. HB2 Filter Fixed Coefficients

Coefficient Number	Normalized Coefficient	Decimal Coefficient (12-Bit)
C1, C27	0.00097656	2
C3, C25	-0.00537109	-11
C5, C23	0.015	32
C7, C21	-0.0380859	-78
C9, C19	0.0825195	169
C11, C17	-0.1821289	-373
C13, C15	0.6259766	1282
C14	1	2048

Similar to the HB1 filter, this filter can either be used or bypassed. Writing Logic 0 to the HB1 enable bit in the FIR-HB

control register bypasses this fixed coefficient HB filter. The filter is useful only in certain filter configurations and bypassing it for other applications results in power savings. For example, the filter is useful in narrow-band applications in which more filtering is required, as compared to wide-band applications, in which a higher output rate might prohibit the use of a decimating filter. The response of the HB2 filter is shown in Figure 52.

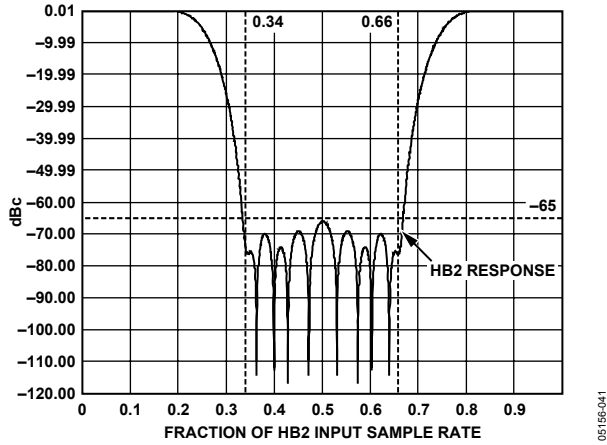

Figure 52. HB2 Filter Response to the Input Rate of the Filter

The filter input sample rate is the same as the FIR2 filter output rate and is given by one of the following equations:

$$f_{HB2} = f_{FIR2} = f_{HB1}, \text{ if HB1 is bypassed}$$

$$f_{HB2} = f_{FIR2} = \frac{f_{HB1}}{2}, \text{ if HB1 is not bypassed}$$

where:

f_{FIR2} is the input rate of the FIR2 filter.

f_{HB2} is the input rate of the HB2 filter.

f_{HB1} is the input rate of the HB1 filter.

The input to the filter has a maximum of 75 MHz. The maximum output rate when not bypassed is 37.5 MHz.

The filter has a ripple of 0.00075 dB and rejection of 81 dB. For an alias rejection of 81 dB, the alias-protected bandwidth is 33% of the filter input sample rate. The bandwidth of the filter for a ripple of 0.00075 dB is the same as alias-protected bandwidth, due to the nature of half-band filters. The 3 dB bandwidth of this filter is 47% of the filter input sample rate. For example, if the sample rate into the filter is 25 MHz, then the alias-protected bandwidth of the HB2 filter is 8.25 MHz (33% of 25 MHz). If the bandwidth of the required carrier is greater than 8.25 MHz, then HB2 might not be useful.

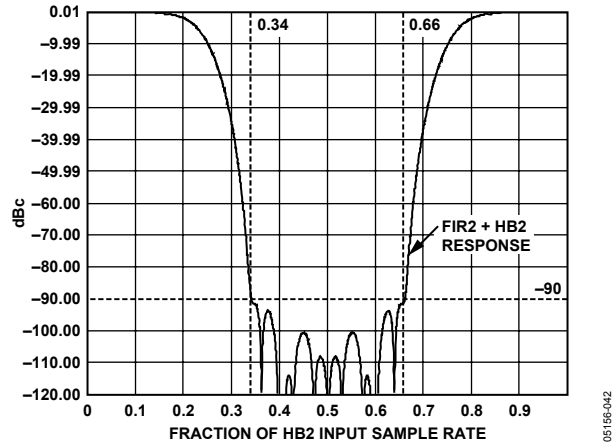

Figure 53. Composite Response of FIR2 and HB2 Filters to Their Input Rates

INTERMEDIATE DATA ROUTER

Following the FIR-HB cascade filters is the intermediate data router. This data router consists of muxes that allow the I and Q data from any channel front end (input port + NCO + CIC + FIRHB) to be processed by any channel back end (MRCF + DRCF + CRCF). The choice of channel front end is made by programming a 3-bit MRCF data select word in the MRCF control register. The valid values for this word and their corresponding settings are listed in Table 19.

Table 19. Data Router Select Settings

MRCF Data Select[2:0]	Data Source
000	Channel 0
001	Channel 1
010	Channel 2
011	Channel 3
1x0	Channel 4
1x1	Channel 5

Allowing different channel back ends to select different channel front ends is useful in the polyphase implementation of filters. When multiple AD6654 channels are used to process a single carrier, a single-channel front end feeds more than one channel back end. After processing through the channel back ends (RCF filters), the data is interleaved back from all the polyphased channels.

MONO-RATE RAM COEFFICIENT FILTER (MRCF)

The MRCF is a programmable sum-of-products FIR filter. This filter block comes after the first data router and before the DRCF and CRCF programmable filters. It consists of a maximum of eight taps with 6-bit programmable coefficients. Note that this block does not decimate and is used as a helper filter for the DRCF and CRCF filters that follow in the signal chain.

The number of filter taps that are to be calculated is programmable using the 3-bit number-of-taps word in the MRCF control register of the channel under consideration. The 3-bit word programmed is one less than the number of filter taps. The coefficients themselves are programmed in eight MRCF coefficient memory registers for individual channels. The input and output data to the block are both 20-bit.

SYMMETRY

Though the MRCF filter does not require symmetrical filters, if the filter is symmetrical, then the symmetry bit in the MRCF control register should be set. When this bit is set, only half of the impulse response needs to be programmed into the MRCF coefficient memory registers. For example, if the number of filter taps is equal to five or six and the filter is symmetrical, then only three coefficients need to be written into the coefficient memory. For both symmetrical and asymmetrical filters, the number of filter taps is limited to eight.

CLOCK RATE

The MRCF filter runs on an internal high speed PLL clock. This clock rate can be as high as 200 MHz. If the half clock rate bit in the MRCF control register is set, then only half the PLL clock rate is used (maximum of 100 MHz). This results in power savings, but can only be used if certain conditions are met.

Because this filter is nondecimating, the input and output rates are both the same and equal to one of the following:

$$f_{MRCF} = f_{HB2}, \text{ if HB2 is not bypassed}$$

$$f_{MRCF} = \frac{f_{HB2}}{2}, \text{ if HB2 is not bypassed}$$

If f_{PLLCLK} is the PLL clock and if

$$f_{MRCF} \times N_{TAPS} \leq \frac{f_{PLLCLK}}{2},$$

then half of the PLL clock can be used for processing (power savings). Otherwise, the PLL clock should be used.

BYPASS

The MRCF filter can be used in normal operation or bypassed using the MRCF bypass bit in the MRCF control register. When the filter is bypassed, the output of the filter is the same as the input of the filter. Bypassing the MRCF filter when not required results in power savings.

SCALING

The output of the MRCF filter can be scaled by using the 2-bit MRCF scaling word in the MRCF control register. Table 20 shows the valid values for the 2-bit word and their corresponding settings.

Table 20. MRCF Scaling Factor Settings

MRCF Scale Word[1:0]	Scaling Factor
00	18.06 dB attenuation
01	12.04 dB attenuation
10	6.02 dB attenuation
11	No scaling, 0 dB

DECIMATING RAM COEFFICIENT FILTER (DRCF)

Following the MRCF is the programmable DRCF FIR filter. This filter can calculate up to 64 asymmetrical filter taps or up to 128 symmetrical filter taps. The filter is also capable of a programmable decimation rate from 1 to 16. A flexible coefficient offset feature allows loading multiple filters into the coefficient RAM and changing the filters on the fly. The decimation phase feature allows a polyphase implementation, where multiple AD6654 channels are used for processing a single carrier.

The DRCF filter has 20-bit input and output data and 14-bit coefficient data. The number of filter taps to calculate is programmable and is set in the DRCF taps register. The value of the number of taps minus one is written to this register. For example, a value of 19 in the register corresponds to 20 filter taps.

The decimation rate is programmable using the 4-bit DRCF decimation rate word in the DRCF control register. Again, the value written is the decimation rate minus one.

BYPASS

The DRCF filter can be used in normal operation or bypassed using the DRCF bypass bit in the DRCF control register. When the DRCF filter is bypassed, no scaling is applied and the output of the filter is the same as the input to the DRCF filter.

SCALING

The output of the DRCF filter can be scaled using the 2-bit DRCF scaling word in the DRCF control register. Table 21 lists the valid values for the 2-bit word and their corresponding settings.

Table 21. DRCF Scaling Factor Settings

DRCF Scale Word[1:0]	Scaling Factor
00	18.06 dB attenuation
01	12.04 dB attenuation
10	6.02 dB attenuation
11	No scaling, 0 dB

SYMMETRY

The DRCF filter does not require symmetrical filters. However, if the filter is symmetrical, then the symmetry bit in the DRCF control register should be set. When this bit is set, only half of the impulse response needs to be programmed into the DRCF coefficient memory registers. For example, if the number of filter taps is equal to 15 or 16 and the filter is symmetrical, then only eight coefficients need to be written into the coefficient memory. Because a total of 64 taps can be written into the memory registers, the DRCF can perform 64 asymmetrical filter taps or 128 symmetrical filter taps.

COEFFICIENT OFFSET

More than one set of filter coefficients can be loaded into coefficient RAM at any given time (given sufficient RAM space). The coefficient offset can be used in this case to access the two or more different filters. By changing the coefficient offset, the filter coefficients being accessed can be changed on the fly. This decimal offset value is programmed in the DRCF coefficient offset register. When this value is changed during the calculation of a particular output data sample, the sample calculation is completed using the old coefficients, and the new coefficient offset from the next data sample calculation is used.

DECIMATION PHASE

When more than one channel of AD6654 is used to process one carrier, polyphase implementation of corresponding channels' DRCF or CRCF is possible using the decimation phase feature. This feature can be used only under certain conditions. The decimation phase is programmed using the 4-bit DRCF decimation phase word of the DRCF control register.

MAXIMUM NUMBER OF TAPS CALCULATED

The output rate of the DRCF filter is given by

$$f_{DRCF} = \frac{f_{MRCF}}{M_{DRCF}}$$

where:

f_{MRCF} is the data rate out of the MRCF filter and into the DRCF filter.

M_{DRCF} is the decimation rate in the DRCF filter.

The DRCF filter consists of two multipliers (one each for the I and Q paths). Each multiplier, working at the high speed clock rate (PLL clock), can do one multiply (or one tap) per high speed clock cycle. Therefore, the maximum number of filter taps that can be calculated (symmetrical or asymmetrical filter) is given by

$$\text{Maximum Number of Taps} = \text{ceil} \left(\frac{f_{PLLCLK}}{f_{DRCF}} \right) - 1$$

where:

f_{PLLCLK} is the high speed internal processing clock generated by the PLL clock multiplier.

f_{DRCF} is the output rate of the DRCF filter, previously calculated.

PROGRAMMING DRCF REGISTERS FOR AN ASYMMETRICAL FILTER

To program the DRCF registers for an asymmetrical filter:

1. Write $NTAPS - 1$ in the DRCF taps register, where $NTAPS$ is the number of filter taps. The absolute maximum value for $NTAPS$ is 64 in asymmetrical filter mode.
2. Write 0 for the DRCF coefficient offset register.
3. Write 0 for the symmetrical filter bit in the DRCF control register.
4. Write the start address for the coefficient RAM, typically equal to the coefficient offset register in the DRCF start address register.
5. In the DRCF stop address register, write the stop address for the coefficient RAM, typically equal to the following:

$$\text{Coefficient Offset} + NTAPS - 1$$
6. Write all coefficients in reverse order (start with last coefficient) to the DRCF coefficient memory register. If in 8-bit microport mode or serial port mode, write the lower byte of the memory register first and then the higher byte. After each write access to the DRCF coefficient memory register, the internal RAM address is incremented starting with the start address and ending with the stop address.

Note that each write or read access increments the internal RAM address. Therefore, all coefficients should be read first before reading them back. Also, for debugging purposes, each RAM address can be written individually by making the start and stop addresses the same. Therefore, to program one RAM location, the user writes the address of the RAM location to both the start and stop address registers, and then writes the coefficient memory register.

PROGRAMMING DRCF REGISTERS FOR A SYMMETRIC FILTER

To program the DRCF registers for a symmetrical filter:

1. Write $NTAPS - 1$ in the DRCF taps register, where $NTAPS$ is the number of filter taps. The absolute maximum value for $NTAPS$ is 128 in symmetric filter mode.
2. Write $\text{ceil}(64 - NTAPS/2)$ for the DRCF coefficient offset register, where the *ceil* function takes the closest integer greater than or equal to the argument.
3. Write 1 for the symmetrical filter bit in the DRCF control register.
4. Write the start address for the coefficient RAM, typically equal to coefficient offset register, in the DRCF start address register.
5. Write the stop address for the coefficient RAM, typically equal to $\text{ceil}(NTAPS/2) - 1$, in the DRCF stop address register.
6. Write all coefficients to the DRCF coefficient memory register, starting with the middle of the filter and working towards the end of the filter. When coefficients are numbered 0 to $NTAPS - 1$, the middle coefficient is given by the coefficient number $\text{ceil}(NTAPS/2)$. If in 8-bit microport mode or serial port mode, write the lower byte of the memory register first and then the higher byte. After each write access to the DRCF coefficient memory register, the internal RAM address is incremented starting with the start address and ending with the stop address.

Note that each write or read access increments the internal RAM address. Therefore, all coefficients should be read first before reading them back. Also, for debugging purposes, each RAM address can be written individually by making the start and stop addresses the same. Therefore, to program one RAM location, the user writes the address of the RAM location to both the start and stop address registers, and then writes the coefficient memory register.

CHANNEL RAM COEFFICIENT FILTER (CRCF)

Following the DRCF is the programmable decimating CRCF FIR filter. The only difference between the DRCF and CRCF filters is the coefficient bit width. The DRCF has 14-bit coefficients, while the CRCF has 20-bit coefficients.

This filter can calculate up to 64 asymmetrical filter taps or up to 128 symmetrical filter taps. The filter is capable of a programmable decimation rate from 1 to 16. The flexible coefficient offset feature allows loading multiple filters into the coefficient RAM and changing the filters on the fly. The decimation phase feature allows for a polyphase implementation in which multiple AD6654 channels are used to process a single carrier.

The CRCF filter has 20-bit input and output data and 20-bit coefficient data. The number of filter taps to calculate is programmable and is set in the CRCF taps register. The value of the number of taps minus one is written to this register. For example, a value of 19 in the register corresponds to 20 filter taps. The decimation rate is programmable using the 4-bit CRCF decimation rate word in the CRCF control register. Again, the value written is the decimation rate minus one.

BYPASS

The CRCF filter can be used in normal operation or bypassed using the CRCF bypass bit in the CRCF control register. When the CRCF filter is bypassed, no scaling is applied and the output of the filter is the same as the input to the CRCF filter.

SCALING

The output of the CRCF filter can be scaled using the 2-bit CRCF scaling word in the CRCF control register. Table 22 shows the valid values for the 2-bit word and the corresponding settings. $|\Sigma_{\text{COEFF}}|$ is the sum of all coefficients (in normalized form) used to calculate the FIR filter.

Table 22. CRCF Scaling Factor Settings

CRCF Scale Word[1:0]	Scaling Factor
00	18.06 dB attenuation
01	12.04 dB attenuation
10	6.02 dB attenuation
11	No scaling, 0 dB

SYMMETRY

The CRCF filter does not require symmetrical filters. However, if the filter is symmetrical, then the symmetry bit in the CRCF control register should be set. When this bit is set, only half the impulse response needs to be programmed into the CRCF coefficient memory registers. For example, if the number of filter taps is equal to 15 or 16 and the filter is symmetric, then only eight coefficients need to be written into the coefficient memory.

Because a total of 64 taps can be written into the memory registers, the CRCF can perform 64 asymmetrical filter taps or 128 symmetrical filter taps.

COEFFICIENT OFFSET

More than one set of filter coefficients can be loaded into the coefficient RAM at any time (given sufficient RAM space). The coefficient offset can be used in this case to access the two or more different filters. By changing the coefficient offset, the filter coefficients being accessed can be changed on the fly. This decimal offset value is programmed in the CRCF coefficient offset register. When this value is changed during the calculation of a particular output data sample, the sample calculation is completed using the old coefficients and the new coefficient offset is brought into effect from the next data sample calculation.

DECIMATION PHASE

When more than one channel of the AD6654 is used to process one carrier, polyphase implementation of the corresponding channels' DRCF or CRCF is possible using the decimation phase feature. This feature can be used only under certain conditions. The decimation phase is programmed using the 4-bit CRCF decimation phase word of the CRCF control register.

MAXIMUM NUMBER OF TAPS CALCULATED

The output rate of the CRCF filter is given by

$$f_{\text{CRCF}} = \frac{f_{\text{DRCF}}}{M_{\text{CRCF}}}$$

where:

f_{DRCF} is the data rate out of the DRCF filter and into the CRCF filter.

M_{CRCF} is the decimation rate in the CRCF filter.

The CRCF filter consists of two multipliers (one each for the I and Q paths). Each multiplier, working at the high speed clock rate (PLL clock), can multiply (or tap once). Therefore, the maximum number of filter taps that can be calculated (symmetrical or asymmetrical filter) is given by

$$\text{Maximum Number of Taps} = \text{ceil}\left(\frac{f_{\text{PLLCLK}}}{f_{\text{CRCF}}}\right) - 1$$

f_{PLLCLK} is the high speed internal processing clock generated by the PLL clock multiplier.

f_{CRCF} is the output rate of the CRCF filter as previously calculated.

PROGRAMMING CRCF REGISTERS FOR AN ASYMMETRICAL FILTER

To program the CRCF registers for an asymmetrical filter:

1. Write $NTAPS - 1$ in the CRCF taps register, where $NTAPS$ is the number of filter taps. The absolute maximum value for $NTAPS$ is 64 in asymmetrical filter mode.
2. Write 0 for the CRCF coefficient offset register.
3. Write 0 for the symmetrical filter bit in the CRCF control register.
4. In the CRCF start address register, write the start address for the coefficient RAM, typically equal to the coefficient offset register.
5. In the CRCF stop address register, write the stop address for the coefficient RAM, typically equal to the following:

$$\text{Coefficient Offset} + NTAPS - 1$$
6. Write all coefficients in reverse order (start with last coefficient) to the CRCF coefficient memory register. In 8 bit microport mode or serial port mode, write the lower byte of the memory register first and then the higher byte. In 16-bit microport mode, write the lower 16-bits of the CRCF memory register first and then the high four bits. After each write access to the CRCF coefficient memory register, the internal RAM address is incremented starting with the start address and ending with the stop address.

Note that each write or read access increments the internal RAM address. Therefore, all coefficients should be read first before reading them back. Also, for debugging purposes, each RAM address can be written individually by making the start and stop addresses the same. Therefore, to program one RAM location, the user writes the address of the RAM location to both the start and stop address registers, and then writes the coefficient memory register.

PROGRAMMING CRCF REGISTERS FOR A SYMMETRICAL FILTER

To program the CRCF registers for a symmetrical filter:

1. Write $NTAPS - 1$ in the CRCF taps register, where $NTAPS$ is the number of filter taps. The absolute maximum value for $NTAPS$ is 128 in symmetrical filter mode.
2. Write $\text{ceil}(64 - NTAPS/2)$ for the CRCF coefficient offset register, where the *ceil* function takes the closest integer greater than or equal to the argument.
3. Write 1 for the symmetrical filter bit in the CRCF control register.
4. In the CRCF start address register, write the start address for the coefficient RAM, typically equal to the coefficient offset register.
5. In the CRCF stop address register, write the stop address for the coefficient RAM, typically equal to $\text{ceil}(NTAPS/2) - 1$.
6. Write all coefficients to the CRCF coefficient memory register, starting with middle of the filter and working towards the end of the filter. When coefficients are numbered 0 to $NTAPS - 1$, the middle coefficient is given by the coefficient number $\text{ceil}(NTAPS/2)$. In 8-bit microport mode or serial port mode, write the lower byte of the memory register first and then the higher byte. In 16-bit microport mode, write the lower 16-bits of the CRCF memory register first and then the high four bits. After each write access to the CRCF coefficient memory register, the internal RAM address is incremented starting with the start address and ending with the stop address.

Note that each write or read access increments the internal RAM address. Therefore, all coefficients should be read first before reading them back. Also, for debugging purposes, each RAM address can be written individually by making the start and stop addresses the same. Therefore, to program one RAM location, the user writes the address of the RAM location to both the start and stop address registers, and then writes the coefficient memory register.

INTERPOLATING HALF-BAND FILTER

The AD6654 has interpolating half-band FIR filters that immediately follow the CRCF programmable FIR filters and precede the second data router. Each interpolating half-band filter takes 22-bit I and 22-bit Q data from the preceding CRCF and outputs rounded 22-bit I and 22-bit Q data to the second data router. A 10-tap fixed coefficient filter is implemented in this stage. The maximum input rate into this block is 17 MHz. Consequently, the maximum output is constrained to 34 MHz. The normalized coefficients used in the implementation and the 10-bit decimal equivalent value of the coefficients are listed in Table 23. Other coefficients are 0.

Table 23. Interpolating HB Filter Fixed Coefficients

Coefficient Number	Normalized Coefficient	Decimal Coefficient (10-Bit)
C1, C11	0.02734375	14
C3, C9	-0.12890625	-66
C5, C7	0.603515625	309
C6	1	512

The half-band filters interpolate the incoming data by $2\times$. For a channel running at $2\times$ the chip rate, the half-band can be used to output channel data at $4\times$ the chip rate. The interpolation operation creates an image of the baseband signal, which is filtered out by the half-band filter.

The image rejection of this filter is about 55 dB, but is sufficient because the image is from the desired signal, not an interfering signal. Note that the interpolating half-band filter can be enabled by writing Logic 1 to Bit 9 of the MRCF control registers.

The frequency response of the interpolating half-band FIR is shown in Table 23 with respect to the chip rate. The input rate to this filter is $2\times$ the chip rate, and the output rate is $4\times$ the chip rate.

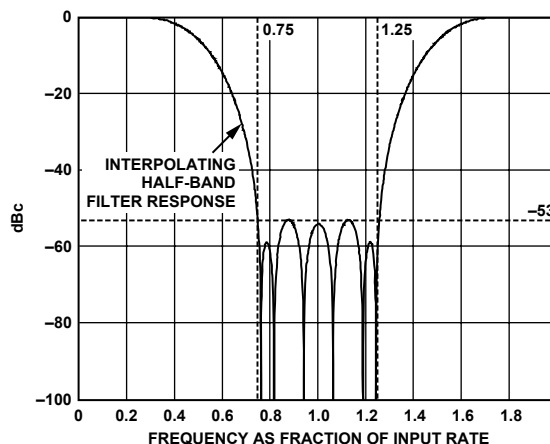

Figure 54. Interpolating Half-Band Frequency Response

OUTPUT DATA ROUTER

The output data router circuit precedes the six AGCs of the final output block and immediately follows interpolating half-band filters. This block consists of two subblocks. The first block is responsible for combining (interleaving) data from more than one channel into a single stream of data. The second block performs complex filter completion, as explained later in this section. The combined data is passed on to the AGCs.

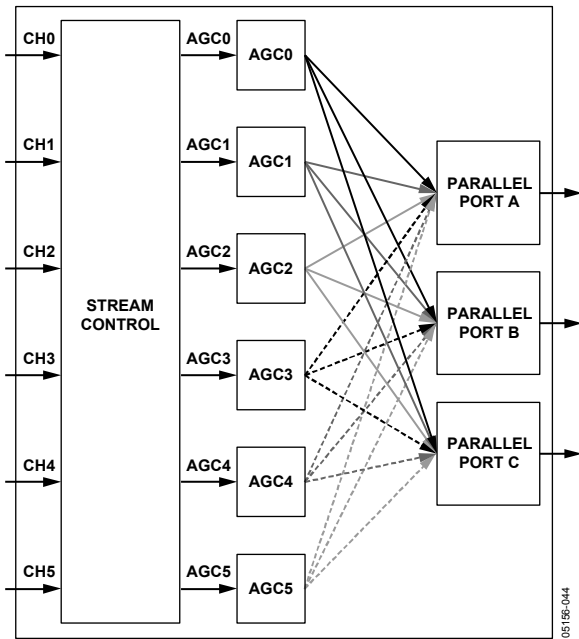

Figure 55. Block Diagram of the Output Data Router

INTERLEAVING DATA

In some cases, filtering using a single channel is insufficient. For such setups, it is advantageous to combine the filtering resources of multiple channels rather than using filtering resources from a single channel.

Multiple channels can be set up to co-process the ADC input port data with the same NCO and filter setups. The decimation phase values in one of the RCF filters are set such that the channel's filters are exactly out of phase with each other. In the data router, these multiple channels are interleaved (combined) to form a single stream of data. Because each individual channel is decimated more than it would have been if a single channel were filtering, more number-of-filter taps can be calculated. This is best illustrated with an example:

Two channels need to work together to produce a filter at an output rate of 9.216 MHz, when the input rate is 92.16 MHz. Each channel is decimated by a factor of 20 (total decimation) to achieve the desired output rate of 4.608 MHz each. This compares to a decimation of 10, if a single channel were working towards filtering.

The same coefficients are programmed into both of the channels' RCF filters, and the decimation phases are set to 0 and 1. The decimation phases can be set to 0 for one channel and 1 for the second channel in the pair. This causes the first channel to produce the even outputs of the filter, and the second to produce the odd outputs of the filter. The streams are then recombined (interleaved) to produce the desired 9.216 MHz output rate. The benefit is that now each channel's RCF has time to calculate twice as many taps, because it has a lower output rate.

The interleaving function is a simple time-multiplexing function, with lower data rate on the input side and higher data rate on the output side. The output data rate is the sum of all input stream data rates that are combined.

The channels that need to be combined are programmable with sufficient flexibility. Table 24 gives the combinations that are possible using a 4-bit word (stream control bits) in the Parallel Port Control 2 register.

Table 24. Stream Control Bit Combinations and Selections

Stream Control Bits	Output Streams	Number of Streams
0000	Ch 0, Ch 1 combined; Ch 2, Ch 3, Ch 4, Ch 5 independent	5
0001	Ch 0, Ch 1, Ch 2 combined; Ch 3, Ch 4, Ch 5 independent	4
0010	Ch 0, Ch 1, Ch 2, Ch 3 combined; Ch 4, Ch 5 independent	3
0011	Ch 0, Ch 1, Ch 2, Ch 3, Ch 4 combined; Ch 5 independent	2
0100	Ch 0, Ch 1, Ch 2, Ch 3, Ch 4, Ch 5 combined	1
0101	Ch 0, Ch 1, Ch 2 combined; Ch 3, Ch 4, Ch 5 combined	2
0110	Ch 0, Ch 1 combined; Ch 2, Ch 3 combined; Ch 4, Ch 5 combined	3
0111	Ch 0, Ch 1 combined; Ch 2, Ch 3 combined; Ch 4, Ch 5 independent	3
1000	Ch 0, Ch 1, Ch 2 combined; Ch 3, Ch 4 combined; Ch 5 independent	3
1001	Ch 0, Ch 1, Ch 2, Ch 3 combined; Ch 4, Ch 5 combined	2
Any other state	Independent channels	6

AUTOMATIC GAIN CONTROL

The AD6654 is equipped with six independent automatic gain control (AGC) loops that directly follow the second data router and immediately precede the parallel output ports. Each AGC circuit has 96 dB of range. It is important that the decimating filters of the AD6654 preceding the AGC reject unwanted signals, so that each AGC loop is operating only on the carrier of interest, and carriers at other frequencies do not affect the ranging of the loop.

The AGC compresses the 22-bit complex output from the second data router into a programmable word size of 4 to 8, 10, 12, or 16 bits. Because the small signals from the lower bits are pushed in to higher bits by adding gain, the clipping of the lower bits does not compromise the SNR of the signal of interest.

The AGC maintains a constant mean power on the output despite the level of the signal of interest, allowing operation in environments where the dynamic range of the signal exceeds the dynamic range of the output resolution. The output width of the AGC is set by writing a 3-bit AGC word-length word in the AGC control register of the individual channel's memory map.

The AGC can be bypassed, if needed, and, when bypassed, the 24-bit complex input word remains truncated to a 16-bit value that is output through the parallel port output. The six AGCs available on the AD6654 are programmable through the six channel memory maps. AGCs corresponding to individual channels can be bypassed by writing Logic 1 to the AGC bypass bit in the AGC control register.

Three sources of error can be introduced by the AGC function: underflow, overflow, and modulation. Underflow is caused by

truncation of bits below the output range. Overflow is caused by clipping errors when the output signal exceeds the output range. Modulation error occurs when the output gain varies while receiving data.

The desired signal level should be set based on the probability density function of the signal, so that the errors due to underflow and overflow are balanced. The gain and damping values of the loop filter should be set, so that the AGC is fast enough to track long-term amplitude variations of the signal that might cause excessive underflow or overflow, but slow enough to avoid excessive loss of amplitude information due to the modulation of the signal.

AGC LOOP

The AGC loop is implemented using a log-linear architecture. It contains four basic operations: power calculation, error calculation, loop filtering, and gain multiplication.

The AGC can be configured to operate in either desired signal level mode or desired clipping level mode. The mode is set by the AGC clipping error bit of the AGC control register. The AGC adjusts the gain of the incoming data according to how far it is from a given desired signal level or desired clipping level, depending on the selected mode of operation.

Two data paths to the AGC loop are provided: one before the clipping circuitry and one after the clipping circuitry, as shown in Figure 56. For the desired signal level mode, only the I/Q path prior to the clipping is used. For the desired clipping level mode, the difference of the I/Q signals from before and after the clipping circuitry is used.

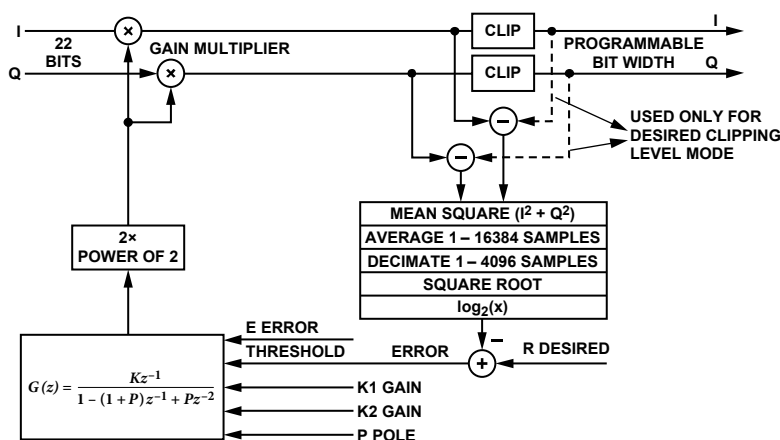

Figure 56. Block Diagram of the AGC

DESIRED SIGNAL LEVEL MODE

In this mode of operation, the AGC strives to maintain the output signal at a programmable set level. The desired signal level mode is selected by writing Logic 0 into the AGC clipping error enable bit of the AGC control register. The loop finds the square (or power) of the incoming complex data signal by squaring I and Q and adding them.

The AGC loop has an average and decimate block. This average and decimate operation takes place on power samples and before the square root operation. This block can be programmed to average from 1 to 16,384 power samples, and the decimate section can be programmed to update the AGC once every 1 to 4,096 samples. The limitation on the averaging operation is that the number of averaged power samples should be a multiple of the decimation value (1×, 2×, 3×, or 4×).

The averaging and decimation effectively means that the AGC can operate over averaged power of 1 to 16,384 output samples. Updating the AGC once every 1 to 4,096 samples and operating on average power facilitates the implementation of the loop filter with slow time constants, where the AGC error converges slowly and makes infrequent gain adjustments. It is also useful when the user wants to keep the gain scaling constant over a frame of data or a stream of symbols.

Due to the limitation that the number of average samples must be a multiple of the decimation value, only the multiple numbers 1, 2, 3, or 4 are programmed. This is set using the AGC average samples word in the AGC average sample register. These averaged samples are then decimated with decimation ratios programmable from 1 to 4,096. This decimation ratio is defined in the 12-bit AGC update decimation register.

The average and decimate operations are tied together and implemented using a first-order CIC filter and FIFO registers. Gain and bit growth are associated with CIC filters and depend on the decimation ratio. To compensate for the gain associated with these operations, attenuation scaling is provided before the CIC filter.

This scaling operation accounts for the division associated with the averaging operation as well as the traditional bit growth in CIC filters. Because this scaling is implemented as a bit-shift operation, only coarse scaling is possible. Fine scaling is implemented as an offset in the request level, as explained later in this section. The attenuation scaling, S_{CIC} , is programmable from 0 to 14 using a 4-bit CIC scale word in the AGC average samples register and is given by

$$S_{CIC} = \text{ceil}[\log_2 (M_{CIC} \times N_{AVG})]$$

where:

M_{CIC} is the decimation ratio (1 to 4,096).

N_{AVG} is the number of averaged samples programmed as a multiple of the decimation ratio (1, 2, 3, or 4).

For example, if a decimation ratio M_{CIC} is 1,000 and N_{AVG} is 3 (decimation of 1,000 and averaging of 3,000 samples), then the actual gain due to averaging and decimation is 3,000 or 69.54 dB ($\log_2(3000)$). Because attenuation is implemented as a bit-shift operation, only multiples of 6.02 dB attenuations are possible. S_{CIC} in this case is 12, corresponding to 72.24 dB. This way, S_{CIC} scaling always attenuates more than is sufficient to compensate for the gain in the average and decimate sections and, therefore, prevents overflows in the AGC loop. But it is also evident that the S_{CIC} scaling induces a gain error (the difference between gain due to CIC and attenuation provided by scaling) of up to 6.02 dB. This error should be compensated for in the request signal level, as explained later in this section.

A logarithm to the Base 2 is applied to the output from the average and decimate sections. These decimated power samples are converted to rms signal samples by applying a square root operation. This square root is implemented using a simple shift operation in the logarithmic domain. The rms samples obtained are subtracted from the request signal level R specified in the AGC desired level register, leaving an error term to be processed by the loop filter, $G(z)$.

The user sets this programmable Request Signal Level R according to the output signal level that is desired. The Request Signal Level R is programmable from -0 dB to -23.99 dB in steps of 0.094 dB.

The request signal level should also compensate for errors, if any, due to the CIC scaling, as previously explained in this section. Therefore, the request signal level is offset by the amount of error induced in CIC, given by

$$\text{Offset} = 10 \times \log(M_{CIC} \times N_{AVG} - S_{CIC} \times 3.01 \text{ dB})$$

where Offset is in dB.

Continuing the previous example, this offset is given by

$$\text{Offset} = 72.24 - 69.54 = 2.7 \text{ dB}$$

So the request signal level is given by

$$R = -\text{ceil}\left[\frac{(DSL - \text{Offset})}{0.094}\right] \times 0.094 \text{ dBFS}$$

where:

R is the request signal level.

DSL (desired signal level) is the output signal level that the user desires.

Therefore, in the previous example, if the desired signal level is -13.8 dB, the request level R is programmed to be -16.54 dB, compensating for the offset.

This request signal level is programmed in the 8-bit AGC desired level register. This register has a floating-point representation, where the 2 MSBs are exponent bits and the 6 LSBs are mantissa bits. The exponent is in steps of 6.02 dB, and the mantissa is in steps of 0.094 dB. For example, a value $10'100101$ represents $2 \times 6.02 + 37 \times 0.094 = 15.518$ dB.

The AGC provides a programmable second-order loop filter. The programmable parameters Gain 1 (K_1), Gain 2 (K_2), Error Threshold E, and Pole P completely define the loop filter characteristics. The error term after subtracting the request signal level is processed by the loop filter, $G(z)$. The open loop poles of the second-order loop filter are 1 and P, respectively. The loop filter parameters, Pole P and Gain K, allow the adjustment of the filter time constant that determines the window for calculating the peak-to-average ratio.

Depending on the value of the error term that is obtained after subtracting the request signal level from the actual signal level, either Gain Value K_1 or Gain Value K_2 is used. If the error is less than the programmable threshold E, K_1 or K_2 is used. This allows a fast loop when the error term is high (large convergence steps required), and a slower loop function when the error term is smaller (almost converged).

The open-loop gain used in the second-order loop $G(z)$ is given by one of the following equations:

$$K = K_1, \text{ if Error} < \text{Error Threshold}$$

$$K = K_2, \text{ if Error} > \text{Error Threshold}$$

The open-loop transfer function for the filter, including the gain parameter, is

$$G(z) = \frac{Kz^{-1}}{1 - (1 + P)z^{-1} + Pz^{-2}}$$

If the AGC is properly configured in terms of offset in the request level, then there are no gains in the AGC loop except for K, the filter gain. Under these circumstances, a closed-loop expression for the AGC loop is given by

$$G_{CLOSED}(z) = \frac{G(z)}{1 + G(z)} = \frac{Kz^{-1}}{1 + (K - 1 - P)z^{-1} + Pz^{-2}}$$

Program K_1 and K_2 (the gain parameters) and Pole P through AGC loop Gain 1 and Gain 2, and AGC pole location registers from 0 to 0.996 in steps of 0.0039 using 8-bit representation. For example, 1000 1001 represent $(137/256 = 0.535156)$. The error threshold value is programmable between 0 dB and 96.3 dB in steps of 0.024 dB. This value is programmed in the 12-bit AGC

error threshold register, using floating-point representation. It consists of four exponent bits and eight mantissa bits. Exponent bits are in steps of 6.02 dB and mantissa bits are in steps of 0.024 dB. For example, 0111'10001001 represents $7 \times 6.02 + 137 \times 0.024 = 45.428$ dB.

The user defines the open-loop Pole P and Gain K, which also directly impact the placement of the closed-loop poles and filter characteristics. These closed-loop poles, P_1 and P_2 , are the roots of the denominator of the previous closed-loop transfer function and are given by

$$P_1, P_2 = \frac{(1 + P - K) \pm \sqrt{(1 + P - K)^2 - 4P}}{2}$$

Typically, the AGC loop performance is defined in terms of its time constant or settling time. In this case, the closed-loop poles should be set to meet the time constants required by the AGC loop.

The relationship between the time constant and the closed-loop poles that can be used for this purpose is

$$P_{1,2} = \exp\left[\frac{M_{CIC}}{\text{Sample Rate} \times \tau_{1,2}}\right]$$

where $\tau_{1,2}$ are the time constants corresponding to Pole P_1 and Pole P_2 .

The time constants can also be derived from settling times as given by

$$\tau = \frac{2\% \text{ settling time}}{4} \text{ or } \frac{5\% \text{ settling time}}{3}$$

M_{CIC} (CIC decimation is from 1 to 4,096), and either the settling time or time constant are chosen by the user. The sample rate is the sample rate of the stream coming into the AGC. If channels were interleaved in the output data router, then the combined sample rate into the AGC should be considered. This rate should be used in the calculation of poles in the previous equation, where the sample rate is mentioned.

The loop filter output corresponds to the signal gain that is updated by the AGC. Because all computation in the loop filter is done in logarithmic domain (to the Base 2) of the samples, the signal gain is generated using the exponent (power of 2) of the loop filter output.

The gain multiplier gives the product of the signal gain with both the I and Q data entering the AGC section. This signal gain is applied as a coarse 4-bit scaling and then as a fine scale 8-bit multiplier. Therefore, the applied signal gain is from 0 to 96.3 dB in steps of 0.024 dB. The initial signal gain is programmable using the AGC signal gain register. This register is again a

4 exponent plus 8 mantissa bit floating-point representation similar to the error threshold. This is taken as the initial gain value before the AGC loop starts operating.

The products of the gain multiplier are the AGC scaled outputs with a 19-bit representation. These are, in turn, used as I and Q for calculating the power, and the AGC error and loop are filtered to produce the signal gain for the next set of samples. These AGC scaled outputs can be programmed to have 4-, 5-, 6-, 7-, 8-, 10-, 12-, or 16-bit widths by using the AGC output word-length word in the AGC control register. The AGC scaled outputs are truncated to the required bit widths by using the clipping circuitry, as shown in Figure 56.

Average Samples Setting

Though it is complicated to express the exact effect of the number of averaging samples by using equations, intuitively it has a smoothing effect on the way the AGC loop addresses a sudden increase or a spike in the signal level. If averaging of four samples is used, the AGC addresses a sudden increase in signal level more slowly compared to no averaging. The same applies to the manner in which the AGC addresses a sudden decrease in the signal level.

DESIRED CLIPPING LEVEL MODE

Each AGC can be configured so that the loop locks onto a desired clipping level or a desired signal level. Desired clipping level mode is selected by writing Logic 1 in the AGC clipping error mode bit in the AGC control register. For signals that tend to exceed the bounds of the peak-to-average ratio, the desired clipping level option provides a way to prevent truncating those signals and still provide an AGC that attacks quickly and settles to the desired output level. The signal path for this mode of operation is shown with dotted lines in Figure 56; the operation is similar to the desired signal level mode.

First, the data from the gain multiplier is truncated to a lower resolution (4, 5, 6, 7, 8, 10, 12, or 16 bits) as set by the AGC output word-length word in the AGC control register. An error term (for both I and Q) is generated that is the difference between the signals before and after truncation. This term is passed to the complex squared magnitude block, for averaging and decimating the update samples and taking their square root to find rms samples as in desired signal level mode. In place of the request desired signal level, a desired clipping level is subtracted, leaving an error term to be processed by the second-order loop filter.

The rest of the loop operates the same way as the desired signal level mode. This way, the truncation error is calculated and the AGC loop operates to maintain a constant truncation error level. The only register setting that is different from the desired signal level mode settings is that the desired clipping level is stored in the AGC desired level registers instead of in the request signal level.

AGC SYNCHRONIZATION

When the AGC output is connected to a RAKE receiver, the RAKE receiver can synchronize the average and update section to update the average power for AGC error calculation and loop filtering. This external sync signal synchronizes the AGC changes to the RAKE receiver and makes sure that the AGC gain word does not change over a symbol period, which, therefore, provides a more accurate estimation. This synchronization is accomplished by setting the appropriate bits of the AGC control register.

Sync Select Alternatives

The AGC can receive a sync as follows:

- Channel sync: The sync signal is used to synchronize the NCO of the channel under consideration.
- Pin sync: Selects one of the four SYNC pins.
- Sync now bit: Through the AGC control register.

When the channel sync select bit of the AGC control register is Logic 1, the AGC receives the sync signal used by the NCO of the corresponding channel for the start. When this bit is Logic 0, the pin sync defined by the 2-bit SYNC pin select word in the AGC control register provides the sync to the AGC. Apart from these two methods, the AGC control register also has a sync now bit that can be used to provide a sync to the AGC by writing to this register through the microport or serial port.

SYNC PROCESS

Regardless of how a sync signal is received, the syncing process is the same. When a sync is received, a start hold-off counter is loaded with the 16-bit value in the AGC hold-off register, which initiates the countdown. The countdown is based on the ADC input clock. When the count reaches 1, a sync is initiated. When a sync is initiated, the CIC decimation filter dumps the current value to the square root, error estimation, and loop filter blocks. After dumping the current value, it starts working toward the next update value. Additionally on a sync, AGC can be initialized, if the initialize AGC on sync bit is set in the AGC control register. During initialization, the CIC accumulator is cleared and new values for CIC decimation, number of averaging samples, CIC scale, signal gain, open-loop Gain K_1 and Gain K_2 , and the Pole P parameter are loaded from their respective registers. When the initialize on sync bit is cleared, these parameters are not loaded from the registers.

This sync process is also initiated when a channel comes out of sleep by using the start sync to the NCO. An additional feature is the first sync only bit in the AGC control register. When this bit is set, only the first sync initiates the process and the remaining sync signals are ignored. This is useful when syncing using a pin sync. A sync is required only on the first pulse on this pin. These additional features make AGC synchronization more flexible and applicable to varied circumstances.

PARALLEL PORT OUTPUT

The AD6654 incorporates three independent 16-bit parallel ports for output data transfer. The three parallel output ports share a common clock, PCLK. Each port consists of a 16-bit data bus, request signal, acknowledge signal, three channel indicator pins, one I/Q indicator pin, one gain word indicator pin, and a common shared PCLK pin. The parallel ports can be configured to function in master mode or slave mode. By default, the parallel ports are in slave mode on power-up.

Each parallel port can output data from any or all of the AGCs, using the 1-bit enable bit for each AGC in the parallel port control register. Even when the AGC is not required for a certain channel, the AGC can be bypassed, but the data is still received from the bypassed AGC. The parallel port functionality is programmable through the two parallel port control registers.

Each parallel port can be programmed individually to operate in either interleaved I/Q mode or parallel I/Q mode. The mode is selected using a 1-bit data format bit in the parallel port control register. In both modes, the AGC gain word output can be enabled using a 1-bit append gain bit in the parallel port control register for individual output ports. There are six enable bits per output port, one for each AGC in the corresponding parallel port.

INTERLEAVED I/Q MODE

Parallel port channel mode is selected by writing a 0 to the data format bit for the parallel port in consideration. In this mode, I and Q words from the AGC are output on the same 16-bit data bus on a time-multiplexed basis. The 16-bit I word is output followed by the 16-bit Q word. The specific AGCs output by the port are selected by setting individual bits for each of the AGCs in the parallel port control register. Figure 57 shows the timing diagram for the interleaved I/Q mode.

When an output data sample is available for output from an AGC, the parallel port initiates the transfer by pulling the PxREQ signal high. In response, the processor receiving the data needs to pull the PxACK signal high, acknowledging that it is ready to receive the signal. In Figure 57, PxACK is already pulled high and, therefore, the 16-bit I data is output on the data bus on the next PCLK rising edge after PxREQ is driven logic high. The PxIQ signal also goes high to indicate that I data is available on the data bus. The next PCLK cycle brings the Q data onto the data bus. In this cycle, the PxIQ signal is driven low. When I data and Q data are output, the channel indicator pins PxCH[2:0] indicate the data source (AGC number).

Figure 57 is the timing diagram for interleaved I/Q mode with the AGC gain word disabled. Figure 58 is a similar timing diagram with the AGC gain word. In the PCLK cycle after the Q data, the AGC gain word is output on the data bus and the PxGAIN signal is pulled high to indicate that the gain word is available on the parallel port. Therefore, a minimum of three or four PCLK cycles are required to output one sample of output data on the parallel port without or with the AGC gain word, respectively.

PARALLEL I/Q MODE

In this mode, eight bits of I data and eight bits of Q data are simultaneously output on the data bus during one PCLK cycle. The I byte is the most significant byte of the port, while the Q byte is the least significant byte. The PAIQ and PBIQ output indicator pins are set high during the PCLK cycle. Note that if data from multiple AGCs are output consecutively, the PAIQ and PBIQ output indicator pins remain high until data from all channels is output. The PACH[2:0] and PBCH[2:0] pins provide a 3-bit binary value indicating the source (AGC number) of the data currently being output. Figure 59 is the timing diagram for parallel I/Q mode.

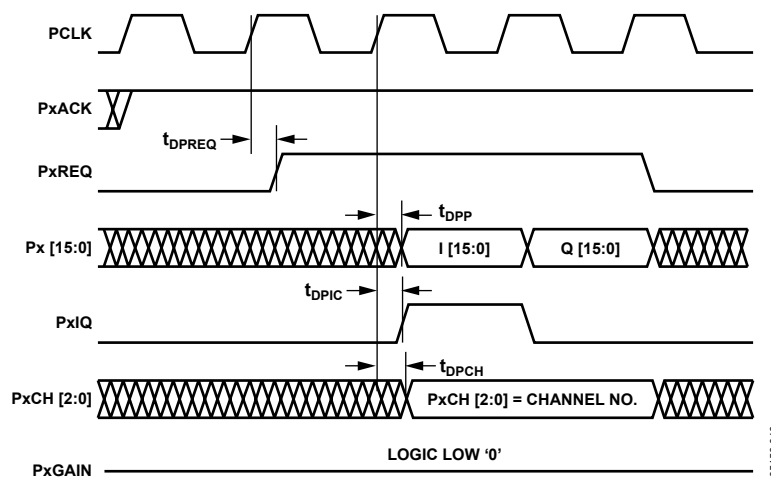

Figure 57. Interleaved I/Q Mode Without an AGC Gain Word

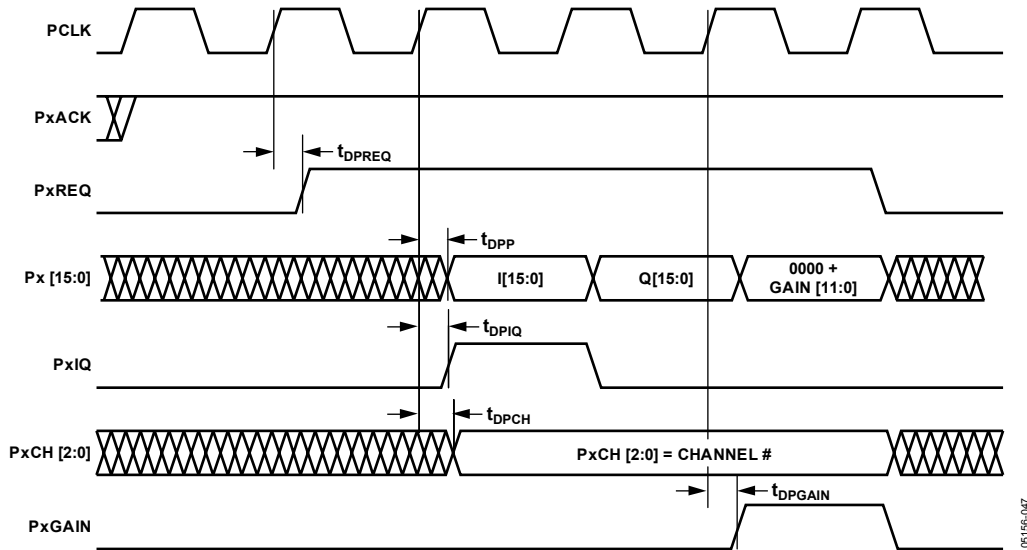

Figure 58. Interleaved I/Q Mode with an AGC Gain Word

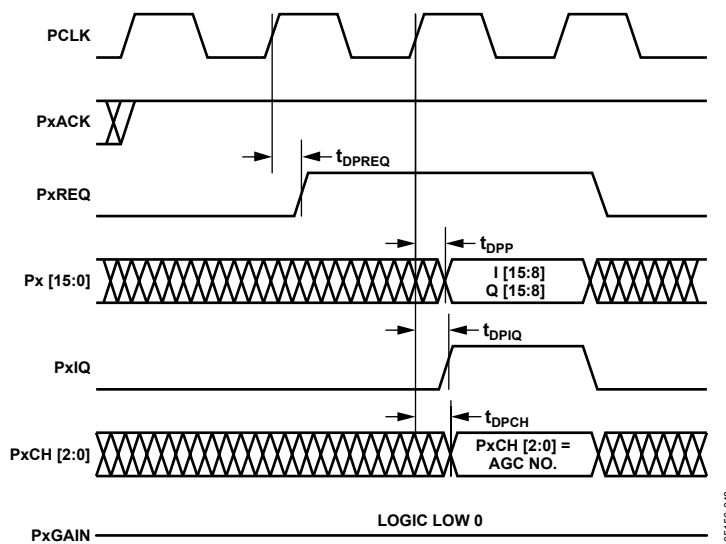

Figure 59. Parallel I/Q Mode Without an AGC Gain Word

When an output data sample is available for output from an AGC, the parallel port initiates the transfer by pulling the PxREQ signal high. In response, the processor receiving the data needs to pull the PxACK signal high, acknowledging that it is ready to receive the signal. In Figure 59, the PxACK is already pulled high and, therefore, the 8-bit I data and 8-bit Q data are simultaneously output on the data bus on the next PCLK rising edge after PxREQ is driven logic high. The PxIQ signal also goes high to indicate that I/Q data is available on the data bus. When I/Q data is being output, the channel indicator pins PxCH[2:0] indicate the data source (AGC number).

Figure 59 is the timing diagram for parallel I/Q mode with the AGC gain word disabled. Figure 60 is a similar timing diagram with the AGC gain word enabled. In the PCLK cycle after the

I/Q data, the AGC gain word is output on the data bus, and the PxGAIN signal is pulled high to indicate that the gain word is available on the parallel port. During this PCLK cycle, the PxIQ signal is pulled low to indicate that I/Q data is not available on the data bus. Therefore, in parallel I/Q mode, a minimum of two PCLK cycles is required to output one sample of output data on the parallel port without and with the AGC gain word, respectively.

The order of data output is dependent on when data arrives at the port, which is a function of total decimation rate, DRCF/CRCF decimation phase, and start hold-off values. Priority order from highest to lowest is, AGC0, AGC1, AGC2, AGC3, AGC4, and AGC5 for both parallel I/Q and interleaved modes of output.

MASTER/SLAVE PCLK MODES

The parallel ports can operate in either master or slave mode. The mode is set via PCLK master mode bit in the Parallel Port Control 2 register. The parallel ports power up in slave mode to avoid possible contentions on the PCLK pin.

In master mode, PCLK is an output derived by dividing PLL_CLK down by the PCLK divisor. The PCLK divisor can have a value of 1, 2, 4, or 8, depending on the 2-bit PCLK divisor word setting in the Parallel Port Control 2 register. The highest PCLK rate in master mode is 200 MHz. Master mode is

selected by setting the PCLK master mode bit in the Parallel Port Control 2 register.

$$PCLK\ rate = \frac{PLL_CLK\ rate}{PCLK\ divisor}$$

In slave mode, external circuitry provides the PCLK signal. Slave mode PCLK signals can be either synchronous or asynchronous. The maximum slave mode PCLK frequency is also 200 MHz.

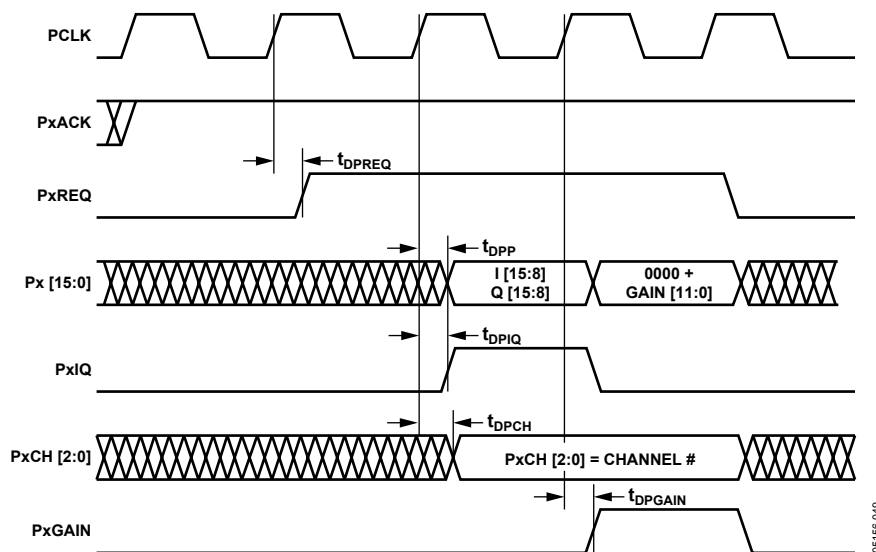

Figure 60. Parallel I/Q Mode with an AGC Gain Word

05156-049

PARALLEL PORT PIN FUNCTIONS

Table 25 describes the functions of the pins used by the parallel ports.

Table 25. Parallel Port Pin Functions

Pin Name	I/O	Function
PCLK	I/O	Parallel Clock. PCLK can operate as a master or as a slave. This setting is dependent on the 1-bit PCLK master mode bit in the Parallel Port Control 2 register. As an output (master mode), the maximum frequency is CLK/N, where CLK is the AD6654 clock and N is an integer divisor of 1, 2, 4, or 8. As an input (slave mode), it can be asynchronous or synchronous relative to the AD6654 CLK. This pin powers up as an input to avoid possible contentions. Parallel port output pins change on the rising edge of PCLK.
PAREQ, PBREQ, PCREQ	O	Active High Output. Synchronous to PCLK. A logic high on this pin indicates that data is available to be shifted out of the port. When an acknowledge signal is received, data starts shifting out and this pin remains high until all pending data has been shifted out.
PAACK, PBACK, PCACK	I	Active High Asynchronous Input. Applying a logic low on this pin inhibits parallel port data shifting. Applying a logic high to this pin when REQ is high causes the parallel port to shift out data according to the programmed data mode. ACK is sampled on the rising edge of PCLK. Assuming that REQ is asserted, the latency from the assertion of ACK to data appearing at the parallel port output is no more than 1.5 PCLK cycles. ACK can be continuously held high; in this case, when data becomes available, shifting begins 1 PCLK cycle after the assertion of REQ (see Figure 57, Figure 58, Figure 59, and Figure 60).
PAIQ, PBIQ, PCIQ		Parallel Output Gain Data Indicators High whenever I data is present on the parallel port data bus; otherwise low. In parallel I/Q mode, both I data and Q data are available at the same time and, therefore, the P _x IQ signal is pulled high.
PAGAIN, PBGAIN, PCGAIN		Parallel Output Gain Word Indicators. High whenever the AGC gain word is present on the parallel port data bus; otherwise low.
PACH[2:0], PBCH[2:0], PCCH[2:0]		Channel Indicator Output Ports. These pins identify data in both of the parallel port modes. The 3-bit value identifies the source of the data (AGC number) on the parallel port when it is being shifted out.
PADATA[15:0], PBDATA[15:0], PCDATA[15:0]		Parallel Output Port Data Bus. Output format is twos complement. In parallel I/Q mode, 8-bit data is present; in interleaved I/Q mode, 16-bit data is available.

USER-CONFIGURABLE BUILT-IN SELF-TEST (BIST)

Each channel of AD6654 includes a BIST block. The BIST, along with an internal test signal (pseudo random test input signal), can be used to generate a signature. This signature can be compared with a known good device and an untested device to see if the untested device is functional.

BIST timer bits in the BIST control register can be programmed with a timer value that determines the number of clock cycles that the output of the channels (output of AGC) have

accumulated. When the disable signature generation bit is written with Logic 0, the BIST timer is counted down and a signature register is written with the accumulated output of the AD6654 channel.

When the BIST timer expires, the signature register for I and Q paths can be read back to compare it with the signature register from a known good device.

CHIP SYNCHRONIZATION

The AD6654 offers two types of synchronization: start sync and hop sync. Start sync is used to bring individual channels out of sleep after programming. It can also be used while AD6654 is operational to resynchronize the internal clocks. Hop sync is used to change or update the NCO frequency tuning word and the NCO phase offset word.

Two methods can be used to initiate a start sync or hop sync:

- Soft sync is provided by the memory map registers and is applied to channels directly through the microport or serial port interface.
- Pin sync is provided using four hard-wired SYNC[3:0] pins. Each channel is programmed to listen to one of these SYNC pins and do a start sync or a hop sync when a signal is received on these pins.

The pin synchronization configuration register (Address 0x04) is used to make pin synchronization even more flexible. The part can be programmed to be edge-sensitive or level-sensitive for SYNC pins. In edge-sensitive mode, a rising edge on the SYNC pins is recognized as a synchronization event.

START

Start refers to the startup of an individual channel or chip, or of multiple chips. If a channel is not used, it should be put into sleep mode to reduce power dissipation. Following a hard reset (low pulse on the RESET pin), all channels are placed into sleep mode. Alternatively, channels can be manually put to sleep by writing 0 to the sleep register.

Start with Soft Sync

The AD6654 can synchronize channels or chips under microprocessor control. The start hold-off counter, in conjunction with the soft start enable bit and the channel enable bits, enables this synchronization.

To synchronize the start of multiple channels via microprocessor control:

1. Write the channel enable register to enable one or more channels, if the channels are inactive.
2. Write the NCO start hold-off counter registers with the appropriate value (greater than 0 and less than 2^{16}).
3. Write the soft sync channel enable bit(s) and soft start synchronization enable bit high in the soft synchronization configuration register. This starts the countdown by the start hold-off counter. When the count reaches 1, the channels are activated or resynchronized.

Note: When using SPI or SPORT for programming these registers, the last step in the above procedure needs to be

repeated, that is, the soft synchronization register needs to be written twice.

Start with Pin Sync

Four sync pins (SYNC0, SYNC1, SYNC2, and SYNC3) provide very accurate synchronization among channels. Each channel can be programmed to monitor any of the four sync pins.

To start the channels with a pin sync:

1. Write the channel register to enable one more channels, if the channels are inactive.
2. Write the NCO start hold-off counter registers with the appropriate value (greater than 0 and less than 2^{16}).
3. Program the channel NCO control registers to monitor the appropriate SYNC pins.
4. Write the start synchronization enable bit and SYNC pin enable bits high in the pin synchronization configuration register. This starts the countdown of the start hold-off counter. When the count reaches 1, the channels are activated or resynchronized.

HOP

Hop is a jump from one NCO frequency and/or phase offset to a new NCO frequency and/or phase offset. This change in frequency and/or phase offset can be synchronized via microprocessor control (soft sync) or via an external sync signal (pin sync).

Hop with Soft Sync

The AD6654 can synchronize a change in NCO frequency and/or phase offset of multiple channels or chips under microprocessor control. The NCO hop hold-off counter, in conjunction with the soft hop enable bit and the channel enable bits, enables this synchronization.

To synchronize the hop of multiple channels via microprocessor control:

1. Write the NCO frequency register(s) or phase offset register(s) to the new value.
2. Write the NCO frequency hold-off counter registers with the appropriate value (greater than 0 and less than 2^{16}).
3. Write 0x00 to the soft synchronization configuration register.
4. Write the soft hop synchronization enable bit and the corresponding soft sync channel enable bits high in the soft synchronization configuration register. This starts the countdown by the frequency hold-off counter. When the

count reaches 1, the new frequency and/or phase offset is loaded into the NCO.

Note: When using SPI or SPORT for programming these registers, the last step in the above procedure needs to be repeated, that is, the soft synchronization register needs to be written twice.

Hop with Pin Sync

Four sync pins (SYNC0, SYNC1, SYNC2, and SYNC3) provide very accurate synchronization among channels. Each channel can be programmed to look at any of the four sync pins.

To control the hop of channel NCO frequencies:

1. Write the NCO frequency register(s) or phase offset register(s) to the new value.
2. Write the NCO frequency hold-off counter(s) to the appropriate value (greater than 0 and less than 2^{16}).
3. Program the channel NCO control registers to monitor the appropriate SYNC pins.
4. Write the hop synchronization enable bit and SYNC pin enable bits high in the pin synchronization configuration register. This enables the countdown of the frequency hold-off counter. When the count reaches 1, the new frequency and/or phase offset is loaded into the NCO.

SERIAL PORT CONTROL

The AD6654 serial port allows all memory to be accessed (programmed or readback) serially in one-byte words. Either serial port or microport can be used (but not both) at any given time. Serial port control is selected using the SMODE pin (0 = microport, 1 = serial port). Two serial port modes are available. An SPI-compatible port is provided as well as a SPORT. The choice of SPI or SPORT mode is selected using the MODE pin (0 = SPI, 1 = SPORT).

Each individual byte of serial data (address, instruction and data) may be shifted in either MSB first or LSB first using the MSBFIRST pin (1 = MSB first, 0 = LSB first). The serial chip select ($\overline{\text{SCS}}$) pin is brought low to access the device for serial control. When the $\overline{\text{SCS}}$ pin is held high, serial programming is inhibited.

HARDWARE INTERFACE

The pins described in Table 26 comprise the physical interface between the user's programming device and the serial port of the AD6654. All serial pins are inputs except for SDO, which is an open-drain output and should be pulled high by an external pull-up resistor (suggested value 1 k Ω).

A complete read or write cycle requires a minimum of three bytes to transfer, consisting of address word, instruction word, and data-word(s). As many as 127 data-words can be transferred during a block transfer cycle. All address, instruction, and data-word(s) must be formatted LSB first or MSB first to match the state of the MSBFIRST pin.

The first word for serial transfer is the internal register address. In LSB first mode, the address is the lower-most address for the block transfer (subsequent addresses are generated by internal increment). In MSB first, the address is highest address for the block transfer (subsequent addresses are generated by internal decrement).

The second word of serial transfer contains a one-bit read/write indicator (1 = read, 0 = write), and seven bits to define the number of data bytes to be transferred (N). For a single data byte transfer (N = 1); one byte is shifted into SDI for a write transfer, or shifted out of SDO for a read transfer, and the cycle is complete. For a block transfer, N write/read operations are performed, and the internal register address increments (MSBFIRST = 0) or decrements (MSBFIRST = 1) after each data byte is clocked into SDI for a write operation, or after each data byte is clocked out of SDO for a read operation.

Figure 61 to Figure 64 illustrate a three byte block transfer through the serial port. Read and write operations with MSBFIRST high and low are shown. Please note that the figures show the sequence for write/read transfer, and actual data should be shifted in or out based upon the status of the MSBFIRST pin. The operation details are common to both SPI and SPORT modes except for the use of framing signals and timing. Individual mode details follow. In single byte transfer mode, the count in the second byte would be reduced to one, and the number of data bytes would be reduced to one.

Table 26. Serial Port Pins

Pin	Function
SCLK	Serial Clock in Both SPI and SPORT Modes. Should have a rise/fall time of 3 ns max.
MSBFIRST	Indicates whether the first bit shifted in or out of the serial port is the MSB (1) or LSB (0) for both instruction and data-words. Also indicates if the first instruction word (address) is a block start or a block end for multiple byte transfers. This pin also controls the functionality when programming indirectly addressed registers.
STFS	Serial Transmit Frame Sync in SPORT Mode. STFS is not used in SPI mode.
SRFS	Serial Receive Frame Sync in SPORT Mode. SRFS is not used in SPI mode.
SDI	Serial Data Input in Both Modes. Serial data is clocked in on the rising edge of SCLK.
SDO	Serial Data Output in Both Modes. Serial data is clocked out on the rising edge of SCLK.
$\overline{\text{SCS}}$	Active-Low Serial Chip Select in Both Modes.
SMODE	Serial Mode. Part is programmed through the serial port when this pin is high.
MODE	Mode Pin. Selects between SPI (0) and SPORT (1) modes.

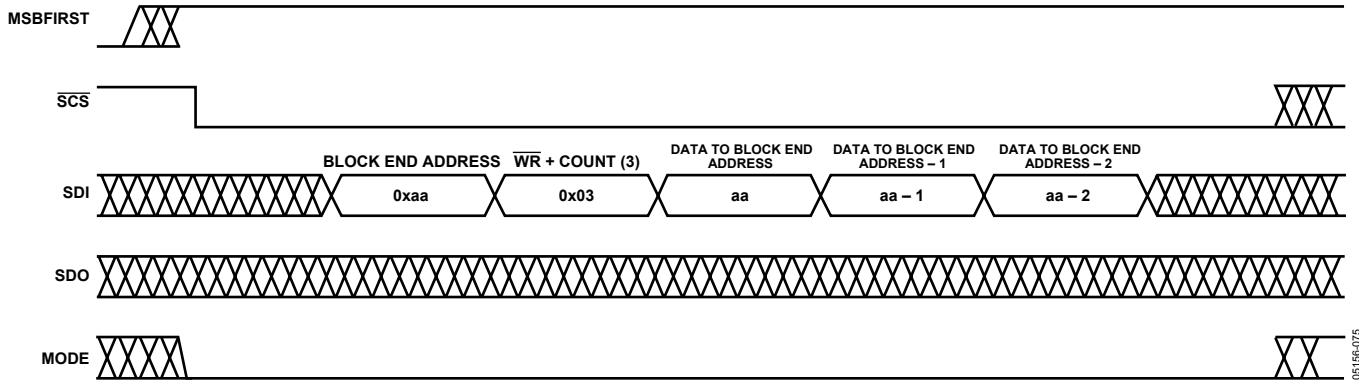

Figure 61. Serial Write of Three Bytes with MSBFIRST = 1 (All Words are Written MSB first)

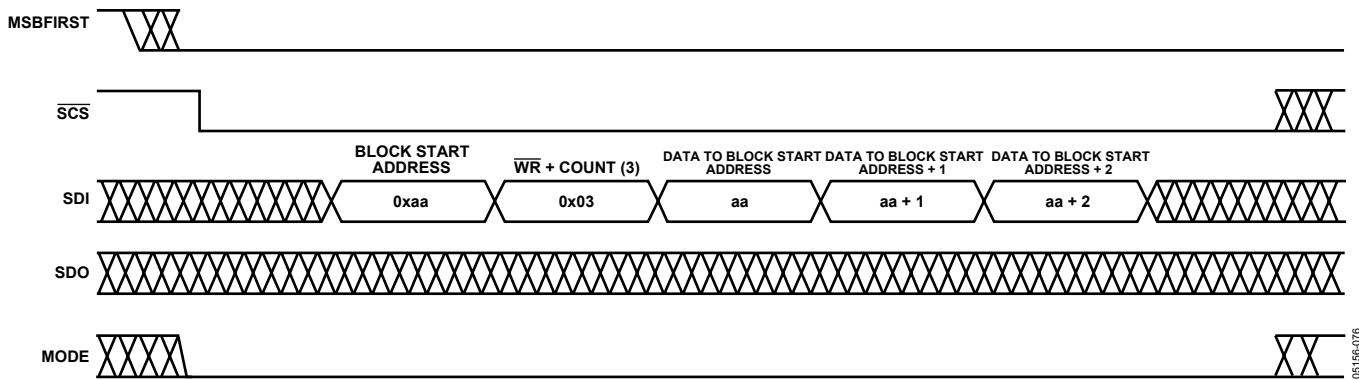

Figure 62. Serial Write of Three Bytes with MSBFIRST = 0 (All Words are Written LSB First)

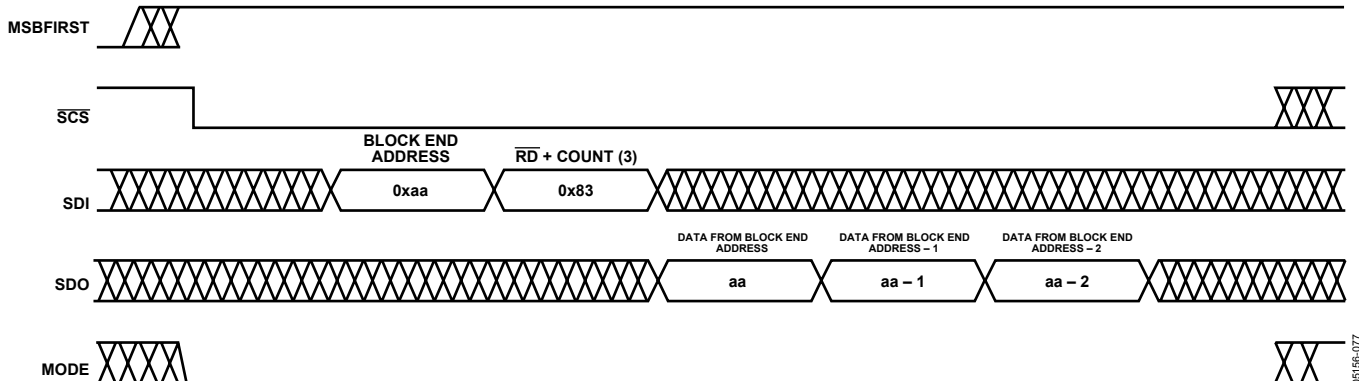

Figure 63. Serial Read of Three Bytes with MSBFIRST = 1 (All Words are Written or Read MSB First)

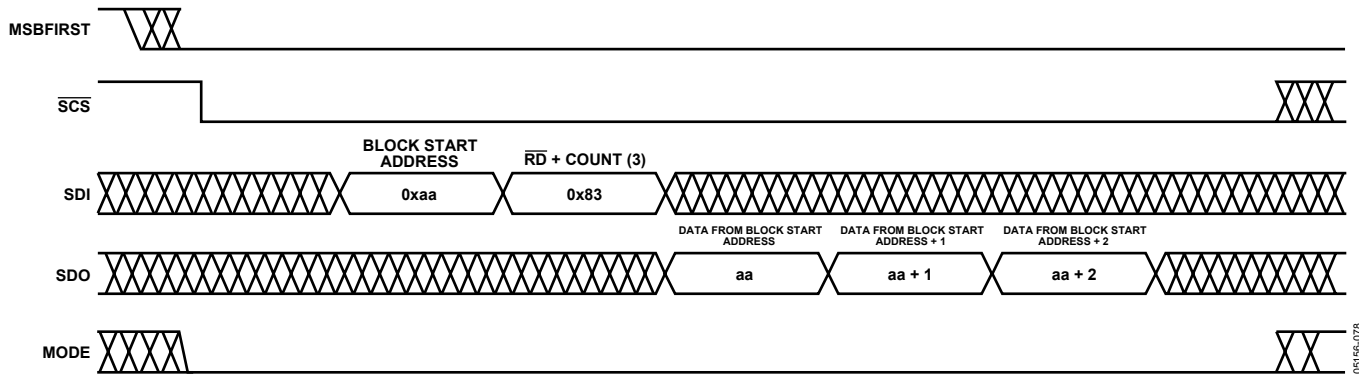

Figure 64. Serial Read of Three Bytes with MSBFIRST = 0 (All Words are Written or Read LSB First)

SPI MODE TIMING

In SPI mode, the SCLK should run only when data is being transferred and \overline{SCS} is logic low. If SCLK runs when \overline{SCS} is logic high, the internal shift register continues to run and instruction words or data are lost. No external framing is necessary. The \overline{SCS} pin can be pulled low once for each byte of transfer, or kept low for the whole length of the transfer.

SPI Write

Data on the SDI pin is registered on the rising edge of SCLK. During a write, the serial port accumulates eight input bits of data before transferring one byte to the internal registers. Figure 65 and Figure 66 show one byte block transfer for writing in MSBFIRST and LSBFIRST modes.

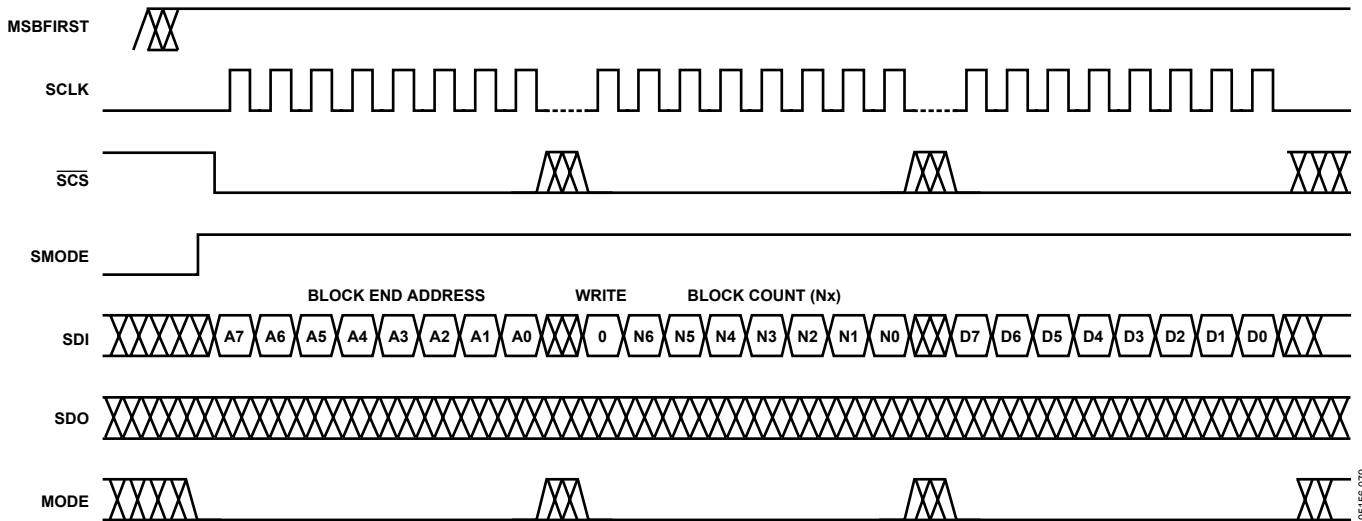

Figure 65. SPI Write MSBFIRST = 1

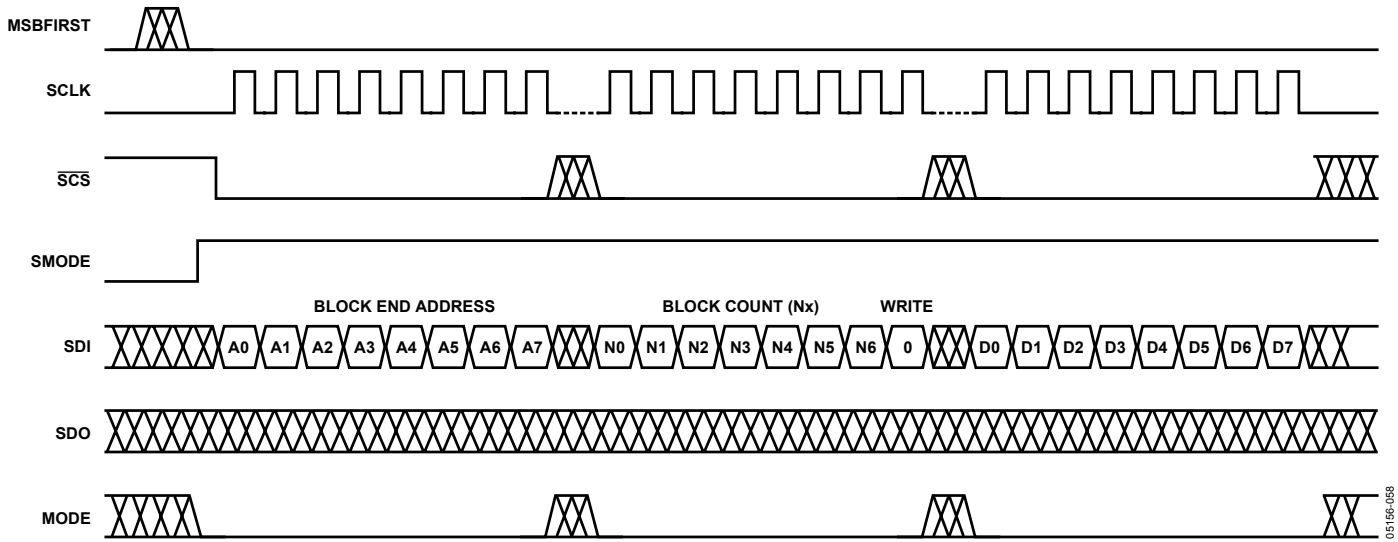

Figure 66. SPI Write MSBFIRST = 0

SPI Read

During a typical read operation, a one byte address and one byte instruction are written to the serial port to instruct the internal control logic as to which registers are to be accessed.

Register readback data shifts out on the rising edge of SCLK. The SDO pin is in a high impedance state at all times except during a read cycle.

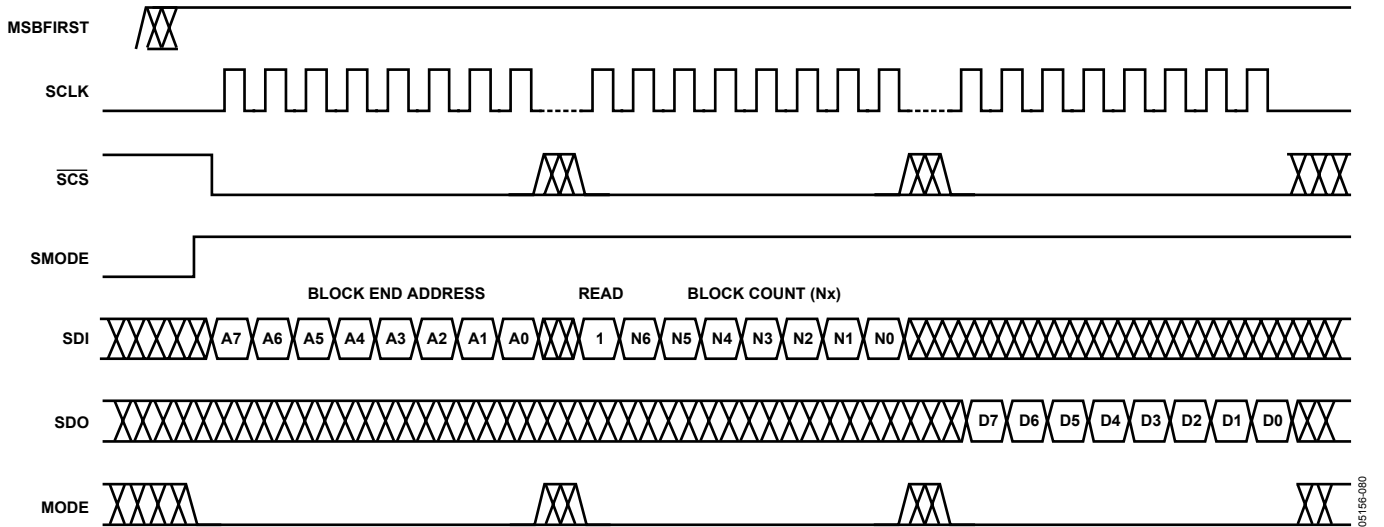

Figure 67. SPI Read MSBFIRST = 1

AD6654

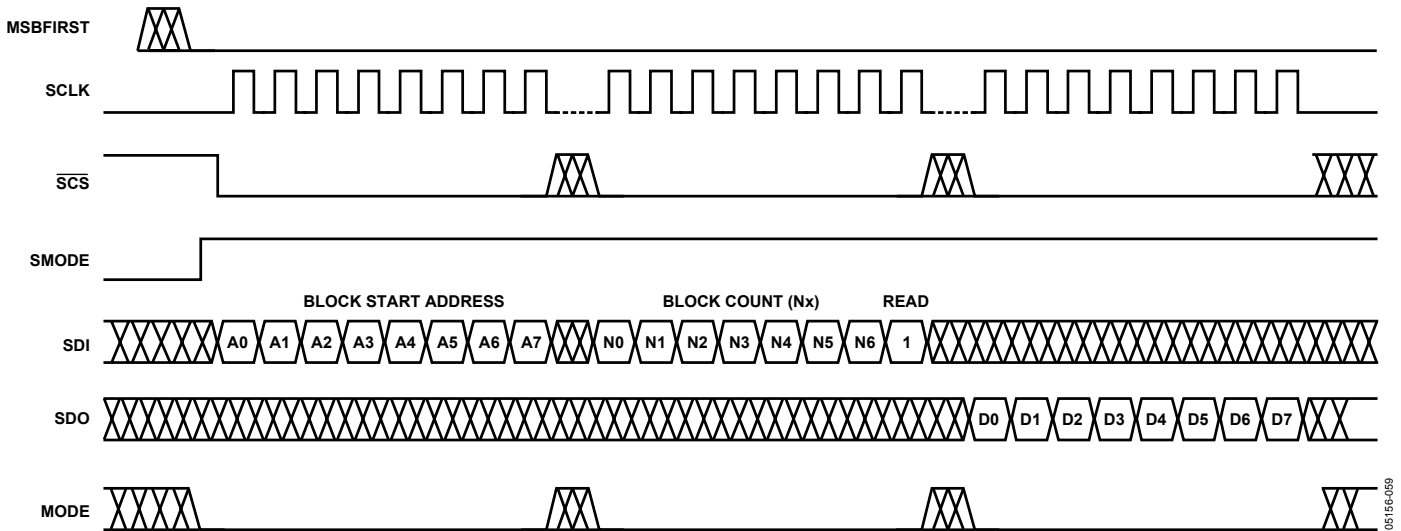

Figure 68. SPI Read MSBFIRST = 0

SPORT MODE TIMING

In SPORT mode, the SCLK continuously runs, and the external SRFS and STFS signals are used to frame the data. Incoming framing signals SRFS (receive) and STFS (transmit) are sampled on the falling edges of SCLK. All input and output data must be transmitted or received in 8-bit segments starting with the rising edge after SRFS or STFS is sampled.

SPORT Write

Serial data is sampled on the rising edge of SCLK. The data should be MSB or LSB first, depending on the polarity of the MSBFIRST pin. The serial port begins to sample data on the rising edge of SCLK after SRFS is detected on the falling edge of SCLK. Once all 8-bits of one byte are shifted in, the data is transferred to the internal bus.

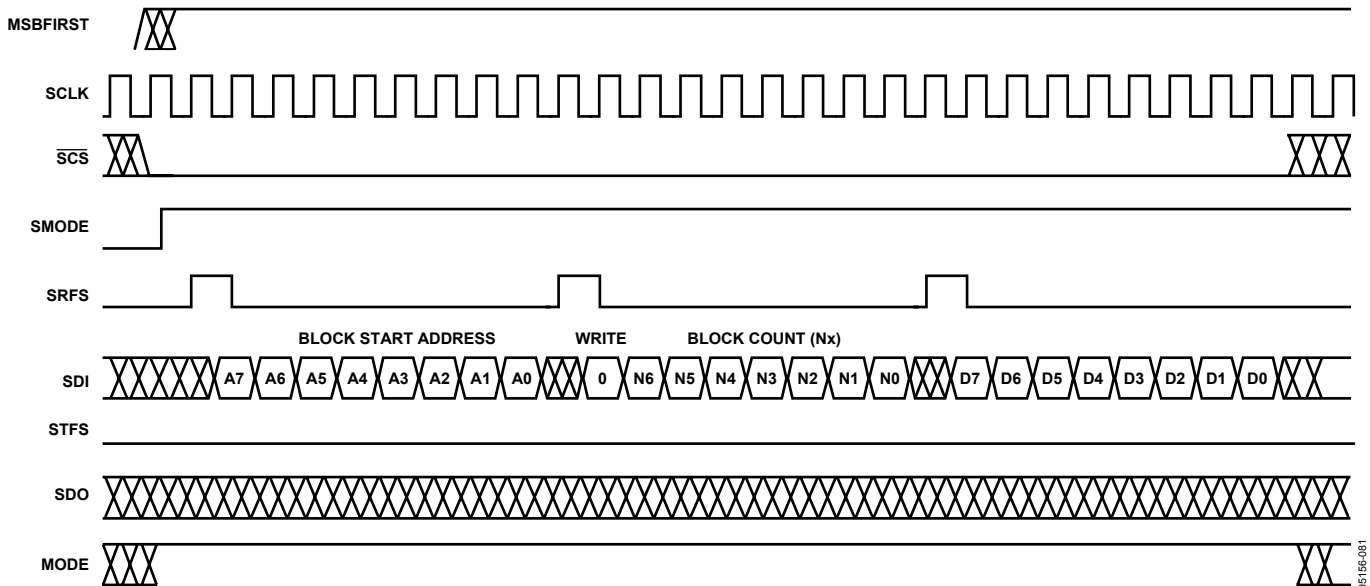

Figure 69. SPORT Write MSBFIRST = 1

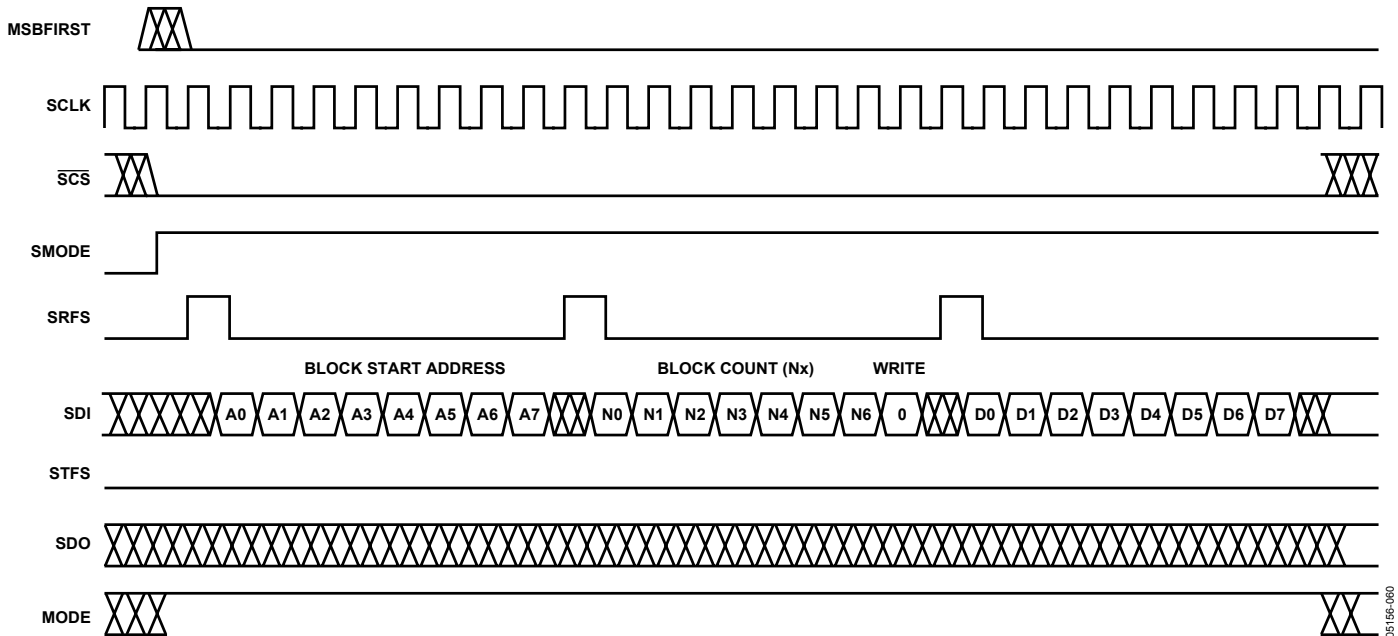

Figure 70. SPORT Write MSBFIRST = 0

SPORT Read

For a typical SPORT read operation, the user must write an address byte and instruction byte to the serial port to instruct the internal control logic as to which registers are to be

readback. STFS must be asserted for every 8-bit readback and is sampled on the falling edge of SCLK. Data is shifted out on the rising edge of SCLK. The SDO pin is in a high impedance state at all times except during a read operation.

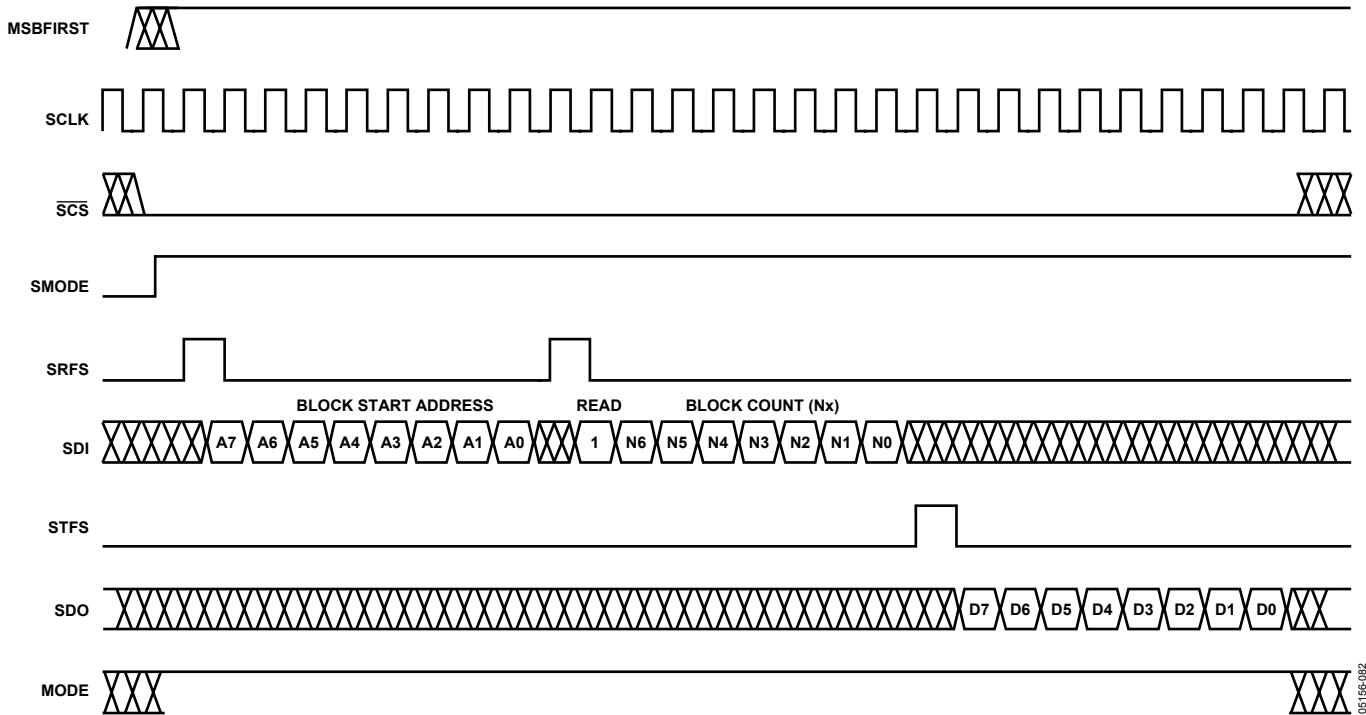

Figure 71. SPORT Read MSBFIRST = 1

AD6654

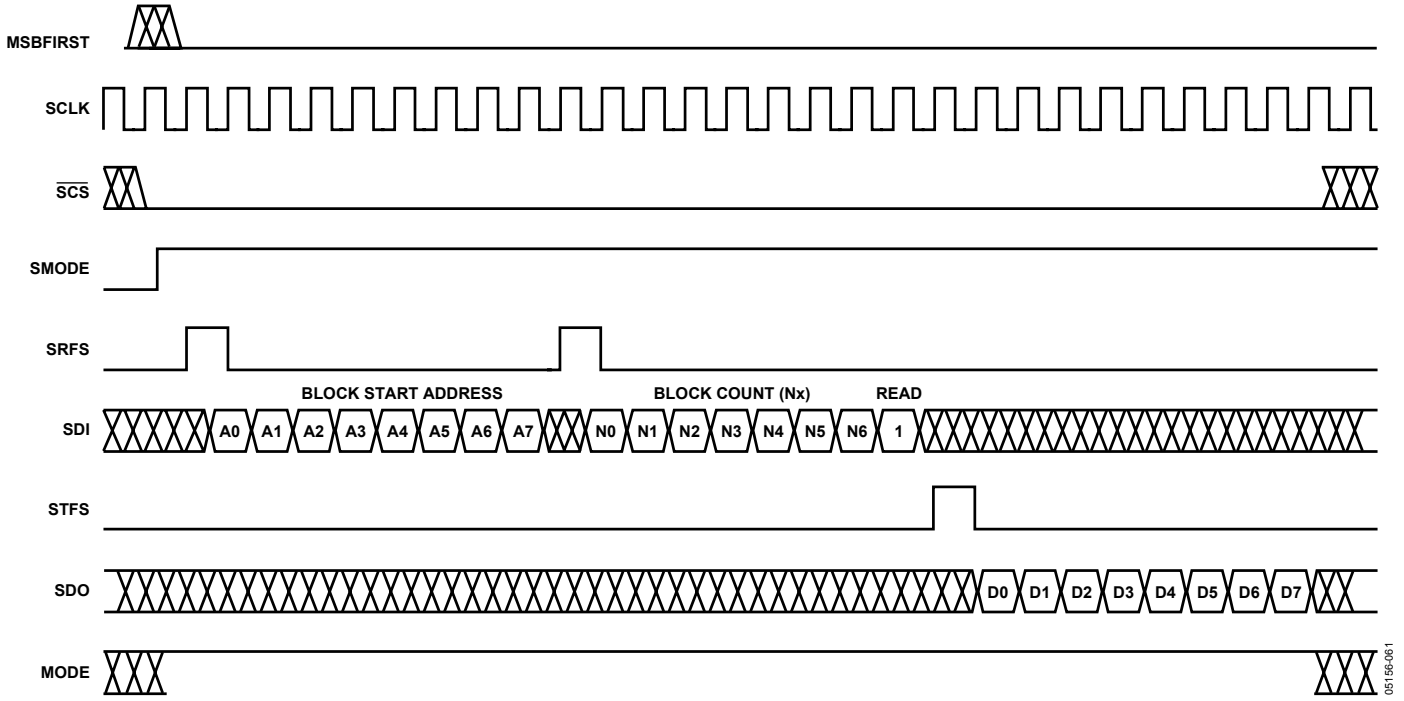

Figure 72. SPORT Read MSBFIRST = 0

05156-061

PROGRAMMING INDIRECT ADDRESSED REGISTERS USING SERIAL PORT

This section gives examples for programming CRCF coefficient RAM (with an indirect addressing scheme) using the serial port (either SPI or SPORT modes). Though the following specific examples are for CRCF coefficient RAM programming, they can be extended to other indirect addressed registers like DRCF coefficient RAM. There are four possible programming scenarios, and examples are given for all scenarios using two commands: SerialWrite(data) and SerialRead. These commands signify an 8-bit write to, or an 8-bit read from, the serial port (SPI or SPORT).

SerialWrite(8-bit number): is an 8-bit write to SPI or SPORT. In SPI mode, the SCLK is toggled eight times while \overline{SCS} is pulled low. In SPORT mode, \overline{SCS} is pulled low, SRFS is held high for one SCLK cycle, and eight bits of data are shifted into the SDI pin following the SRFS pulse. Though the 8-bit number argument shown in the following code is always shown MSBFIRST, it is written with MSB shifting into the device first in MSBFIRST mode, and it is written with LSB shifting into the device first in LSBFIRST mode.

SerialRead(): is an 8-bit read from the SDO pin in SPI or SPORT modes. In SPI mode, the SCLK toggles eight times while \overline{SCS} is low. In SPORT mode, \overline{SCS} is pulled low, STFS is held high for one SCLK cycle, and then the eight bits of data that shifted out on SDO following the STFS pulse are read. The data shifted out should be interpreted based on the polarity of the MSBFIRST pin.

MSBFIRST Mode Using Single Byte Block Transfers

```
SerialWrite(0x98); //CRCF Start Address
SerialWrite(0x01);
SerialWrite(0x00);

SerialWrite(0x99); //CRCF Final Address
SerialWrite(0x01);
SerialWrite(N-1); //N is the number of coefficients

for (i=0 ; i < N; i++) { //writing registers

    SerialWrite(0x9E); //MSB written first
    SerialWrite(0x01);
    //data bits[23:16]
    SerialWrite(coeff[i] >> 16 & 0xFF);

    SerialWrite(0x9D);
    SerialWrite(0x01);
    //data bits[15:8]
    SerialWrite(coeff[i] >> 8 & 0xFF);

    SerialWrite(0x9C); //LSB written last
    SerialWrite(0x01);
    //data bits[7:0]
    SerialWrite(coeff[i] & 0xFF);

}

SerialWrite(0x98); //CRCF Start Address
SerialWrite(0x01);
SerialWrite(0x00);

SerialWrite(0x99); //CRCF Final Address
SerialWrite(0x01);
SerialWrite(N-1); //N is the number of coefficients

for (i=0 ; i < N; i++) { //reading registers

    SerialWrite(0x9E); //MSB readback first
    SerialWrite(0x81);
    //data bits[23:16]
    Coeff[i] = SerialRead() << 16;

    SerialWrite(0x9D);
    SerialWrite(0x81);
    //data bits[15:8]
    Coeff[i] |= SerialRead() << 8;

    SerialWrite(0x9C); //LSB readback last
    SerialWrite(0x81);
    //data bits[7:0]
    Coeff[i] |= SerialRead();

}
}
```

LSBFIRST Mode Using Single Byte Block Transfers

```

SerialWrite(0x98); //CRCF Start Address
SerialWrite(0x01);
SerialWrite(0x00);

SerialWrite(0x99); //CRCF Final Address
SerialWrite(0x01);
SerialWrite(N-1); //N is the number of coefficients

for (i=0 ; i < N; i++) { // writing registers
    SerialWrite(0x9C); //LSB written first
    SerialWrite(0x01);
    //data bits[7:0]
    SerialWrite(coeff[i] & 0xFF);

    SerialWrite(0x9D);
    SerialWrite(0x01);
    //data bits[15:8]
    SerialWrite(coeff[i] >> 8 & 0xFF);

    SerialWrite(0x9E); //MSB written last
    SerialWrite(0x01);
    //data bits[23:16]
    SerialWrite(coeff[i] >> 16 & 0xFF);
}

SerialWrite(0x98); //CRCF Start Address
SerialWrite(0x01);
SerialWrite(0x00);

SerialWrite(0x99); //CRCF Final Address
SerialWrite(0x01);
SerialWrite(N-1); //N is the number of coefficients

for (i=0 ; i < N; i++) { //reading registers
    SerialWrite(0x9C); //LSB readback first
    SerialWrite(0x81);
    //data bits[7:0]
    Coeff[i] = SerialRead();

    SerialWrite(0x9D);
    SerialWrite(0x81);
    //data bits[15:8]
    Coeff[i] |= SerialRead() << 8;

    SerialWrite(0x9E); //MSB readback last
    SerialWrite(0x81);
    //data bits[23:16]
    Coeff[i] |= SerialRead() << 16;
}

```

MSBFIRST Mode Using Multi Byte Block Transfers

```

SerialWrite(0x99); //CRCF Final Address
SerialWrite(0x02);
SerialWrite(N-1); //N is the number of coefficients
SerialWrite(0x00);

for (i=0 ; i < N; i++) { //writing registers
    SerialWrite(0x9E);
    SerialWrite(0x03);
    //data bits[23:16]
    SerialWrite(coeff[i] >> 16 & 0xFF);
    //data bits[15:8]
    SerialWrite(coeff[i] >> 8 & 0xFF);
    //data bits[7:0]
    SerialWrite(coeff[i] & 0xFF);
}

SerialWrite(0x99); //CRCF Final Address
SerialWrite(0x02);
SerialWrite(N-1); //N is the number of coefficients
SerialWrite(0x00);

for (i=0 ; i < N; i++) { //reading registers
    SerialWrite(0x9E);
    SerialWrite(0x83);
    //data bits[23:16]
    Coeff[i] = SerialRead() << 16;
    //data bits[15:8]
    Coeff[i] |= SerialRead() << 8;
    //data bits[7:0]
    Coeff[i] |= SerialRead();
}

LSBFIRST Mode Using Multi Byte Block Transfers

SerialWrite(0x98); //CRCF Start Address
SerialWrite(0x02);
SerialWrite(0x00);
SerialWrite(N-1); //N is the number of coefficients

for (i=0 ; i < N; i++) { //writing registers
    SerialWrite(0x9C);
    SerialWrite(0x03);
    //data bits[7:0]
    SerialWrite(coeff[i] & 0xFF);
    //data bits[15:8]
    SerialWrite(coeff[i] >> 8 & 0xFF);
    //data bits[23:16]
    SerialWrite(coeff[i] >> 16 & 0xFF);
}

SerialWrite(0x98); //CRCF Start Address
SerialWrite(0x02);
SerialWrite(0x00);
SerialWrite(N-1); //N is the number of coefficients

for (i=0 ; i < N; i++) { //reading registers
    SerialWrite(0x9C);
    SerialWrite(0x83);
    //data bits[7:0]
    Coeff[i] = SerialRead();
    //data bits[15:8]
    Coeff[i] |= SerialRead() << 8;
    //data bits[23:16]
    Coeff[i] |= SerialRead() << 16;
}

```

CONNECTING THE AD6654 SERIAL PORT TO A BLACKFIN DSP

In SPI mode, the Blackfin DSP must act as a master to the AD6654 by providing the SCLK. SDO is an open-drain output, so that multiple slave devices can be connected together.

Figure 73 shows a typical connection.

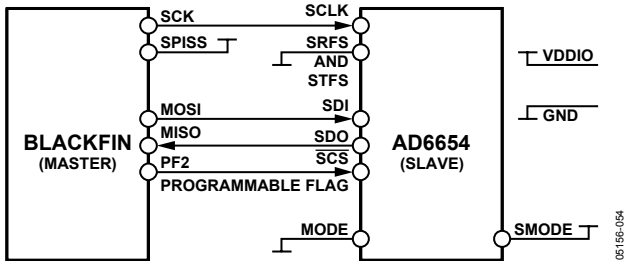

Figure 73. SPI Mode Serial Port Connection to Blackfin DSP

In SPORT mode, the Blackfin provides the SCLK, SRFS, and STFS signals, as shown in Figure 74.

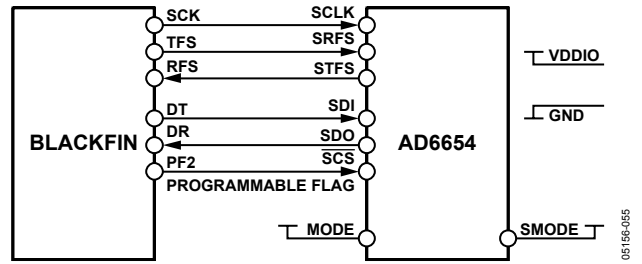

Figure 74. SPORT Mode Serial Port Connections to Blackfin

MICROPORT

The microport on the AD6654 can be used for programming the part, reading register values, and reading output data (I, Q, and RSSI words).

Note that, at any given point in time, either the microport or the serial port can be active, but not both. Some of the balls on the package are shared between the microport and the serial port and have dual functionality based on the SMODE pin. The microport is selected by pulling the SMODE pin low (ground).

Both read and write operations can be performed using the microport. The direct addressing scheme is used and any internal register can be accessed using an 8-bit address. The data bus can be either 8-bit or 16-bit as set by the chip I/O access control register. Microport operation is synchronous to CPUCLK, which must be supplied external to the AD6654 part. CPUCLK should be less than CLK and 100 MHz.

The microport can operate in Intel mode (separate read and write strobes) or in Motorola mode (single read/write strobe). The MODE pin is used to select between Intel (INM, MODE = 0) and Motorola (MNM, MODE = 1) modes. Some AD6654 pins have dual functionality based on the MODE pin. Table 27 lists the pin functions for both modes.

Table 27. Microport Programming Pins

Pin Name	Intel Mode	Motorola Mode
RESET	RESET	RESET
SMODE	Logic 0	Logic 0
MODE	Logic 0	Logic 1
A[7:0]	A[7:0]	A[7:0]
D[15:0]	D[15:0]	D[15:0]
R/W (\overline{WR})	\overline{WR}	R/W
\overline{DS} (\overline{RD})	\overline{RD}	\overline{DS}
\overline{DTACK} (RDY)	RDY	\overline{DTACK}
\overline{CS}	\overline{CS}	\overline{CS}

INTEL (INM) MODE

The programming port performs synchronous Intel-style reads and writes on the positive edge of the CPUCLK input when RESET is inactive (active low signal). The CPUCLK pin is driven by the programming device (CPUCLK of DSP or FPGA). During a write access, the A[7:0] address bus provides the address for access, and the D[15:0] bus (D[7:0] if the 8-bit data bus is used) is driven by the programming device. The data bus is driven by the AD6654 during a read operation. Intel mode uses separate read (\overline{RD}) and write (\overline{WR}) active low data strobes to indicate both the type of access and the valid data for that access.

The chip select (\overline{CS}) is an active-low input that signals when an access is active on its programming port pins. During an access, the AD6654 drives RDY low to indicate that it is performing the

access. When the internal read or write access is complete, the RDY pin is pulled high. Because the RDY pin is an open-drain output with a weak internal pull-up resistor (70 k Ω), an external pull-up resistor is recommended (see the DDC Design Notes section). Figure 10 and Figure 11 are the timing diagrams for read and write cycles using the microport in INM mode.

For an asynchronous write operation in Intel (INM) mode, the CPUCLK should be running. Set up the data and address buses. Pull the \overline{WR} signal low and then pull the \overline{CS} signal low. The RDY goes low to indicate that the access is taking place internally. When RDY goes high, the write cycle is complete and \overline{CS} can be pulled high to disable the microport.

For an asynchronous read operation on the Intel mode microport, set up the address bus and three-state the data bus. Pull the \overline{RD} signal low and then pull the \overline{CS} signal low. The RDY goes low to indicate an internal access. When RDY goes low, valid data is available on the data bus for read.

MOTOROLA (MNM) MODE

The programming port performs synchronous Motorola-style reads and writes on the positive edge of CPUCLK when RESET is inactive (active low signal). The A[7:0] bus provides the address to access and the D[15:0] bus (D[7:0], if the 8-bit data bus is used) is externally driven with data during a write (driven by the AD6654 during a read). Motorola mode uses the R/W line to indicate the type of access (Logic 1 = read, Logic 0 = write), and the active low data strobe (\overline{DS}) signal is used to indicate valid data.

The chip select (\overline{CS}) is an active-low input that signals when an access is active on its programming port pins. When the read/write cycle is complete, the AD6654 drives \overline{DTACK} low. The \overline{DTACK} signal goes high again after either the \overline{CS} or \overline{DS} signal is driven high. Because the \overline{DTACK} pin is an open-drain output with a weak internal pull-up resistor (70 k Ω), an external pull-up resistor is recommended (see the DDC Design Notes section). Figure 12 and Figure 13 are the timing diagrams for read and write cycles using the microport in MNM mode.

For an asynchronous write operation on the Motorola mode microport, the CPUCLK should be running. Set up the data and address buses. Pull the $\overline{R/W}$ and \overline{DS} signals low and then pull the \overline{CS} signal low. The \overline{DTACK} goes low after a few clock cycles to indicate that the write access is complete and that \overline{CS} can be pulled high to disable the microport. For an asynchronous read operation on the Motorola mode microport, set up the address bus and three-state the data bus. Pull the \overline{RD} signal low and then pull the \overline{CS} signal low. The \overline{DTACK} goes low after a few clock cycles to indicate that valid data is on the data bus.

ACCESSING MULTIPLE AD6654 DEVICES

If multiple AD6654 devices are on a single board, the microport pins for these devices can be shared. In this configuration, a single programming device (DSP, FPGA, or microcontroller) can program all AD6654 devices connected to it.

Each AD6654 has four CHIPID pins that can be connected in 16 different ways. During a write/read access, the internal circuitry checks to see if the CHIPID bits in the chip I/O access control register (Address 0x02) are the same as the logic levels

of the CHIPID pins (hardwired to the part). If the CHIPID bits and the CHIPID pins have the same value, then a write/read access is completed; otherwise, the access is ignored.

To program multiple devices using the same microport control and data buses, the devices should have separate CHIPID pin configurations. A write/read access can be made only on the intended chip; all other chips would ignore the access.

MEMORY MAP

READING THE MEMORY MAP TABLE

Each row in the memory map table has four address locations. The memory map is roughly divided into four regions: global register map (Address 0x00 to Address 0x0B), input port register map (Address 0x0C to Address 0x67), channel register map (Address 0x68 to Address 0xBB), and output port register map (Address 0xBC to Address 0xE7). The channel register map is shared by all six channels, and access to individual channels is given by the channel I/O access control register (Address 0x02).

In the memory map in Table 28, the addresses are given in the right column. The column with the heading Byte 0 has the address given in the right column. The column Byte 1 has the address given by 1 more than the address listed in the right column (address offset of 1). Similarly, the address offset for the Byte 2 column is 2, and for the Byte 3 column is 3. For example, the second row lists 0x04 as the address in the right column. The pin synchronization configuration register has Address 0x04, the soft synchronization configuration register has Address 0x05, and Address 0x06 and Address 0x07 are reserved/open.

BIT FORMAT

All registers are in little-endian format. For example, if a register takes 24 bits or three address locations, then the most significant byte is at the highest address location and the least significant byte is at a lowest address location. In all registers, the least significant bit is Bit 0 and the most significant bit is Bit 7. For example, the NCO frequency <31:0> register is 32 bits wide. Bit 0 (LSB) of this register is written at Bit 0 of Address 0x70 and Bit 32 (MSB) of this register is written at Bit 7 of Address 0x73.

When referring to a register that takes up multiple address locations, it is referred to by the address location of the most significant byte of the register. For example, the text reads, “Port A dwell timer at Address 0x2A.” Note that only the four most significant bits of this register are at this location, and this register also takes up Addresses 0x29 and 0x28.

OPEN LOCATIONS

All locations marked as open are currently not used. When required, these locations should be written with 0s. Writing to these locations is required only when part of an address location is open (for example, Address 0x78). If the whole address location is open (for example, Address 0x00), then this address location does not need to be written. If the open locations are read back using the microport or serial port, the readback value is undefined (each bit can be independently 1 or 0), and these bits have no significance.

If an address location has more than one register or has one register with some open bits, then the order of these registers is as given in Table 28. For example, Address 0x33 reads

Open <7:5>, Port A Signal Monitor <4:0>.

The open <7:5> is located at Bits <7:5> and the Port A signal monitor <4:0> is located at Bits <4:0>.

Another example is Address 0x35:

Open <15:10>, Port A Upper Threshold <9:0>

Here, Bits <7:2> of Address 0x35 are open <15:10>. Bits <1:0> of Address 0x35 and Bits <7:0> of Address 0x34 make up the Port A upper threshold <9:0> register (Bit 1 of Address 0x35 is the MSB of the Port A upper threshold register).

DEFAULT VALUES

Coming out of reset, some of the address locations (but not all) are loaded with default values. When available, the default values for the registers are given in the table. If the default value is not listed, then the address location is in an undefined state (Logic 0 or Logic 1) on RESET.

LOGIC LEVELS

In the explanation of various registers, “bit is set” is synonymous with “bit is set to Logic 1” or “writing Logic 1 for the bit.” Similarly “clear a bit” is synonymous with “bit is set to Logic 0” or “writing Logic 0 for the bit.”

Table 28. Memory Map

8-Bit Hex Address	Byte 3	Byte 2	Byte 1	Byte 0	8-Bit Hex Address
0x03	Open <7:6>, Channel Enable <5:0>	Open <7:6>, Channel I/O Access Control <5:0>	Chip I/O Access Control <7:0> (default 0x00)	Open <7:0>	0x00
0x07	Open <15:11>, Reserved <10:0> (default 0x06FC)		Soft Synchronization Configuration <7:0>	Pin Synchronization Configuration <7:0>	0x04
0x0B	Interrupt Mask <15:0>		Interrupt Status <15:0> (read only, default 0x00)		0x08
ADC Input Port Register Map—Addresses 0x0C to 0x57					
0x0F	ADC Input Control <31:0>				0x0C
0x13	Open <15:0>	ADC CLK Control <15:0> (default 0x0000)			0x10
0x4B	ADC Gain Control <7:0>	Open <23:20>, ADC Dwell Timer <19:0>			0x48
0x4F	Open <7:0>	ADC Power Monitor Period <23:0>			0x4C
0x53	Open <7:5>, ADC Signal Monitor <4:0>	ADC Power Monitor Output <23:0>			0x50
0x57	Open <15:10>, ADC Lower Threshold <9:0>		Open <15:10>, ADC Upper Threshold <9:0>		0x54
Channel Register Map—Addresses 0x68 to 0xBB					
0x6B	Open <15:0>		Open <15:9>, NCO Control <8:0>		0x68
0x6F	NCO Start Hold-Off Counter <15:0>		NCO Frequency Hold-Off Counter <15:0>		0x6C
0x73	NCO Frequency <31:0> (default 0x0000 0000)				0x70
0x77	Open <15:0>		NCO Phase Offset <15:0> (default 0x0000)		0x74
0x7B	Open <7:1>, CIC Bypass <0>	Open <7:5>, CIC Decimation <4:0>	Open <7:5>, CIC Scale Factor <4:0>	Open <7:4>, FIR-HB Control <3:0>	0x78
0x7F	Open <15:0>		Open <15:13>, MRCF Control <12:0>		0x7C
0x83	Open <7:6>, MRCF Coefficient 3 <5:0>	Open <7:6>, MRCF Coefficient 2 <5:0>	Open <7:6>, MRCF Coefficient 1 <5:0>	Open <7:6>, MRCF Coefficient 0 <5:0>	0x80
0x87	Open <7:6>, MRCF Coefficient 7 <5:0>	Open <7:6>, MRCF Coefficient 6 <5:0>	Open <7:6>, MRCF Coefficient 5 <5:0>	Open <7:6>, MRCF Coefficient 4 <5:0>	0x84
0x8B	Open <15:13>, DRCF Control Register <12:0>				0x88
0x8F	Open <15:0>		Open <7:6>, DRCF Coefficient Offset <5:0>	Open <7>, DRCF Taps <6:0>	0x8C
0x93	Open <15:0>		Open <7:6>, DRCF Final Address <5:0>	Open <7:6>, DRCF Start Address <5:0>	0x8C
0x97	Open <15:13>, CRCF Control Register <12:0>		Open <15:14>, DRCF Coefficient Memory <13:0>		0x90
0x9B	Open <15:0>		Open <7:6>, CRCF Coefficient Offset <5:0>	Open <7>, CRCF Taps <6:0>	0x94
0x9F	Open <15:0>		Open <7:6>, CRCF Final Address <5:0>	Open <7:6>, CRCF Start Address <5:0>	0x98
0xA3	Open <7:0>	Open <23:20>, CRCF Coefficient Memory <19:0>			0x9C
0xA7	Open <15:11>, AGC Control Register <10:0>		AGC Hold-Off Register <15:0>		0xA0
0xAB	Open <15:12>, AGC Update Decimation <11:0>		Open <15:12>, AGC Signal Gain <11:0>		0xA4
0xAB	Open <15:12>, AGC Error Threshold <11:0>		Open <7:6>, AGC Average Samples <5:0>	AGC Pole Location <7:0>	0xA8
0xAF	Open <7:0>	AGC Desired Level <7:0>	AGC Loop Gain2 <7:0>	AGC Loop Gain1 <7:0>	0xAC
0xB3	Open <7:0>		BIST I Path Signature Register <23:0> (read only)		0xB0
0xB7	Open <7:0>		BIST Q Path Signature Register <23:0> (read only)		0xB4
0xBB	Open <15:0>		BIST Control <15:0>		0xB8
Output Port Register Map—Addresses 0xBC to 0xE7					
0xBF	Open <7:0>		Parallel Port Output Control <23:0>		0xBC
0xC3	Open <15:0>		Open <15:10>, Output Port Control <9:0>		0xC0
0xC7	AGC0, I Output <15:0> (read only)		AGC0, Q Output <15:0> (read only)		0xC4
0xCB	AGC1, I Output <15:0> (read only)		AGC1, Q Output <15:0> (read only)		0xC8
0xCF	AGC2, I Output <15:0> (read only)		AGC2, Q Output <15:0> (read only)		0xCC
0xD3	AGC3, I Output <15:0> (read only)		AGC3, Q Output <15:0> (read only)		0xD0
0xD7	AGC4, I Output <15:0> (read only)		AGC4, Q Output <15:0> (read only)		0xD4
0xDB	AGC5, I Output <15:0> (read only)		AGC5, Q Output <15:0> (read only)		0xD8
0xDF	Open <15:12>, AGC0 RSSI Output <11:0> (read only)		Open <15:12>, AGC1 RSSI Output <11:0> (read only)		0xDC
0xE3	Open <15:12>, AGC2 RSSI Output <11:0> (read only)		Open <15:12>, AGC3 RSSI Output <11:0> (read only)		0xE0
0xE7	Open <15:12>, AGC4 RSSI Output <11:0> (read only)		Open <15:12>, AGC5 RSSI Output <11:0> (read only)		0xE4

GLOBAL REGISTER MAP

Chip I/O Access Control Register <7:0>

<7>: Synchronous Microport Bit. When this bit is set, the microport assumes that its control signals (such as $\overline{R/W}$, \overline{DS} , and \overline{CS}), are synchronous to the CPUCLK. When cleared, asynchronous control signals are assumed, and the microport control signals are resynchronized with CPUCLK inside the AD6654 part. Synchronous microport (when bit is set) has the advantage of requiring a fewer number of clock cycles for read/write access.

<6>: This bit is open.

<5:2>: Chip ID Bits. The chip ID bits are used to compare against the chip ID input pins (CHIPID), enabling or disabling I/O access for this specific chip. When more than one AD6654 part is sharing the microport, different CHIPID pins can be used to differentiate among the parts. A particular part gives I/O access only when the CHIPID pins have the same value as these chip ID bits.

<1>: This bit is open.

<0>: Byte Mode Bit. The byte mode bit selects the bit width for the microport operation. Table 29 shows details.

Table 29. Microport Data Bus Width Selection

Chip Access Control Register <0>	Microport Data Bus Bit Width
0 (default)	8-bit mode, using D <7:0>
1	16-bit mode, using D <15:0>

Channel I/O Access Control Register <5:0>

These bits enable/disable the channel I/O access capability.

<5>: Channel 5 Access Bit. When the Channel 5 access bit is set to Logic 1, any I/O write operation (from either the microport or the serial port) that addresses a register located within the channel register map updates the Channel 5 registers. Similarly, for a read operation, the contents of the desired address in the channel register map are output when this bit is set to Logic 1.

<4>: Channel 4 Access Bit. Similar to Bit <5> for Channel 4.

<3>: Channel 3 Access Bit. Similar to Bit <5> for Channel 3.

<2>: Channel 2 Access Bit. Similar to Bit <5> for Channel 2.

<1>: Channel 1 Access Bit. Similar to Bit <5> for Channel 1.

<0>: Channel 0 Access Bit. Similar to Bit <5> for Channel 0.

Note: If the access bits are set for more than one channel, during write access all channels with access are written with the same data. This is especially useful when more than one channel has similar configurations. During a read operation, if more than

one channel has access, the read access is given to the channel with the lowest channel number.

For example, if both Channel 4 and Channel 2 have access bits set, then read access is given to Channel 2.

Channel Enable Register <5:0>

<5>: Channel 5 Enable Bit. When this bit is set, Channel 5 logic is enabled. When this bit is cleared, Channel 5 is disabled and the channel's logic does not consume any power. On power-up, this bit comes up with Logic 0 and the channel is disabled. A start sync does not start Channel 5, unless this bit is set before issuing the start sync.

<4>: Channel 4 Enable Bit. Similar to Bit <5> for Channel 4.

<3>: Channel 3 Enable Bit. Similar to Bit <5> for Channel 3.

<2>: Channel 2 Enable Bit. Similar to Bit <5> for Channel 2.

<1>: Channel 1 Enable Bit. Similar to Bit <5> for Channel 1.

<0>: Channel 0 Enable Bit. Similar to Bit <5> for Channel 0.

Pin Synchronization Configuration <7:0>

<7>: Hop Synchronization Enable Bit. This bit is a global enable for any hop synchronization involving SYNC pins. When this bit is set, hop synchronization is enabled for all channels that are programmed for pin synchronization. When this bit is cleared, hop synchronization is not performed for any channel that is programmed for pin synchronization.

<6>: Start Synchronization Enable Bit. This bit is a global enable for any start synchronization involving SYNC pins. When this bit is set, start synchronization is enabled for all channels that are programmed for pin synchronization. When this bit is cleared, start synchronization is not performed for any channel that is programmed for pin synchronization.

<5>: First Sync Only Bit. When this bit is set, the NCO synchronization logic recognizes only the first synchronization event as valid. All other requests for synchronization events are ignored as long as this bit is set. When cleared, all synchronization events are acted upon.

<4>: Edge-Sensitivity Bit. When this bit is set, the rising edge on the SYNC pin(s) is detected as a synchronization event (edge-sensitive detection). When cleared, Logic 1 on the SYNC pin(s) is detected as a synchronization event (level-sensitive detection).

<3>: Enable Synchronization from SYNC3 Bit. When this bit is set, the SYNC3 pin can be used for synchronization. When this bit is cleared, the SYNC3 pin is ignored. This is a global enable for all SYNC pins, and each individual channel selects which pin it listens to.

<2>: Enable Synchronization from SYNC2 Bit. Similar to Bit <3> for the SYNC2 pin.

<1>: Enable Synchronization from SYNC1 Bit. Similar to Bit <3> for the SYNC1 pin.

<0>: Enable Synchronization from SYNC0 Bit. Similar to Bit <3> for the SYNC0 pin.

Soft Synchronization Configuration <7:0>

<7>: Soft Hop Synchronization Enable Bit. When this bit is set, hop synchronization is enabled for all channels selected using Bit 5 through Bit 0. When this bit is cleared, hop synchronization is not performed for any channels selected using Bit 5 to Bit 0.

<6>: Soft Start Synchronization Enable Bit. When this bit is set, start synchronization is enabled for all channels selected using Bit 5 through Bit 0. When this bit is cleared, start synchronization is not performed for any channels selected using Bit 5 to Bit 0.

Bits <5:0> form the SOFT_SYNC control bits. These bits can be written to by the controller to initiate the synchronization of a selected channel.

<5>: Soft Sync Channel 5 Enable Bit. When this bit is set, it enables Channel 5 to receive a hop sync or start sync, as defined by Bit 7 and Bit 6, respectively. When cleared, Channel 5 does not receive any soft sync.

<4>: Soft Sync Channel 4 Enable Bit. Similar to Bit <5> for Channel 4.

<3>: Soft Sync Channel 3 Enable Bit. Similar to Bit <5> for Channel 3.

<2>: Soft Sync Channel 2 Enable Bit. Similar to Bit <5> for Channel 2.

<1>: Soft Sync Channel 1 Enable Bit. Similar to Bit <5> for Channel 1.

<0>: Soft Sync Channel 0 Enable Bit. Similar to Bit <5> for Channel 0.

<10:0>: Reserved.

<10:9>: Reserved. This bit must be written with Logic 1.

<8:0>: Reserved. This bit must be written with Logic 0.

Interrupt Status Register <15:0>

This register is read only.

<15>: AGC5 RSSI Update Interrupt Bit. If the AGC5 update interrupt enable bit is set, this bit is set by the AD6654 whenever AGC5 updates a new RSSI word (the new word should be different from the previous word). If the AGC5

update interrupt enable bit is cleared, then this bit is not set (not updated). An interrupt is not generated in this case.

Note: For Bits <15:10>, no interrupt is generated, if the new RSSI word is the same as the previous RSSI word.

<14>: AGC4 RSSI Update Interrupt Bit. Similar to Bit <15> for the AGC4.

<13>: AGC3 RSSI Update Interrupt Bit. Similar to Bit <15> for the AGC3.

<12>: AGC2 RSSI Update Interrupt Bit. Similar to Bit <15> for the AGC2.

<11>: AGC1 RSSI Update Interrupt Bit. Similar to Bit <15> for the AGC1.

<10>: AGC0 RSSI Update Interrupt Bit. Similar to Bit <15> for the AGC0.

<9>: Channel 5 Data Ready Interrupt Bit. This bit is set to Logic 1 whenever the channel BIST signature registers are loaded with data. The conditions required for setting this bit are that the channel BIST signature registers are programmed for BIST signature generation and the Channel 5 data ready enable bit in the interrupt enable register is cleared. If the Channel 5 data ready enable bit in the interrupt enable register is set, the AD6654 does not set this bit on signature generation and an interrupt is not generated.

<8>: Channel 4 Data Ready Interrupt Bit. Similar to Bit <9> for Channel 4.

<7>: Channel 3 Data Ready Interrupt Bit. Similar to Bit <9> for Channel 3.

<6>: Channel 2 Data Ready Interrupt Bit. Similar to Bit <9> for Channel 2.

<5>: Channel 1 Data Ready Interrupt Bit. Similar to Bit <9> for Channel 1.

<4>: Channel 0 Data Ready Interrupt Bit. Similar to Bit <9> for Channel 0.

<3>: Reserved. This bit must be written with Logic 0.

<2>: ADC Port Power Monitoring Interrupt Bit. This bit is set by the AD6654 whenever the ADC port power monitor interrupt enable bit is set and the ADC port power monitor timer runs out (end of the ADC port power monitor period). If the ADC port power monitor interrupt enable bit is cleared, the AD6654 does not set this bit and does not generate an interrupt.

<1>: Reserved. This bit must be written with Logic 0.

<0>: Reserved. This bit must be written with Logic 0.

Interrupt Enable Register <15:0>

<15>: AGC5 RSSI Update Enable Bit. When this bit is set, the AGC5 RSSI update interrupt is enabled, allowing an interrupt to be generated when the RSSI word is updated.

When this bit is cleared, an interrupt cannot be generated for this event. Also, see the Interrupt Status Register <15:0> section.

<14>: AGC4 RSSI Update Enable Bit. Similar to Bit <15> for the AGC4.

<13>: AGC3 RSSI Update Enable Bit. Similar to Bit <15> for the AGC3.

<12>: AGC2 RSSI Update Enable Bit. Similar to Bit <15> for the AGC2.

<11>: AGC1 RSSI Update Enable Bit. Similar to Bit <15> for the AGC1.

<10>: AGC0 RSSI Update Enable Bit. Similar to Bit <15> for the AGC0.

<9>: Channel 5 Data Ready Enable Bit. When this bit is set, the Channel 5 data ready interrupt is enabled, allowing an interrupt to be generated when Channel 5 BIST signature registers are updated. When this bit is cleared, an interrupt cannot be generated for this event.

<8>: Channel 4 Data Ready Enable Bit. Similar to Bit <9> for Channel 4.

<7>: Channel 3 Data Ready Enable Bit. Similar to Bit <9> for Channel 3.

<6>: Channel 2 Data Ready Enable Bit. Similar to Bit <9> for Channel 2.

<5>: Channel 1 Data Ready Enable Bit. Similar to Bit <9> for Channel 1.

<4>: Channel 0 Data Ready Enable Bit. Similar to Bit <9> for Channel 0.

<3>: Reserved. This bit must be written with Logic 0.

<2>: ADC Port Power Monitoring Enable Bit. When this bit is set to Logic 1, the ADC port power monitoring interrupt is enabled, allowing an interrupt to be generated when ADC port power monitoring registers are updated. When set to Logic 1, the ADC port power monitoring interrupt is disabled.

<1>: Reserved. This bit must be written with Logic 0.

<0>: Reserved. This bit must be written with Logic 0.

INPUT PORT REGISTER MAP

ADC Input Control Register <27:0>

These bits are general control bits for the ADC input logic.

<27>: PN Active Bit. When this bit is set, the pseudorandom number generator is active. When this bit is cleared, the PN generator is disabled and the seed is set to its default value.

<26>: EXP Lock Bit. When this bit is set along with the PN active bit, then the EXP signal for pseudorandom input is locked to 000 (giving full-scale input). When this bit is cleared, EXP bits for pseudorandom input are randomly generated input data bits.

<25> Reserved. This bit must be written with Logic 0.

<24> Reserved. This bit must be written with Logic 0.

<23:20>: Channel 5 Cross Bar Mux Select Bits. These bits select the source of input data for Channel 5. See Table 30.

Table 30. Input Data Source Selection

Cross Bar Mux Select Bits	Configuration
0010	ADC port drives input (real)
0100	PN sequence drives input (real)

<19>: Reserved. This bit must be written with Logic 0.

<18:16>: Channel 4 Cross Bar Mux Select Bits. Similar to bits <22:20>, but for Channel 4.

<15>: Reserved. This bit must be written with Logic 0.

<14:12>: Channel 3 Cross Bar Mux Select Bits. Similar to Bits <22:20> for Channel 3.

<11>: Reserved. This bit must be written with Logic 0.

<10:8>: Channel 2 Cross Bar Mux Select Bits. Similar to Bits <22:20> for Channel 2.

<7>: Reserved. This bit must be written with Logic 0.

<6:4>: Channel 1 Cross Bar Mux Select Bits. Similar to Bits <22:20> for Channel 1.

<3>: Reserved. This bit must be written with Logic 0.

<2:0>: Channel 0 Cross Bar Mux Select Bits. Similar to Bits <22:20> for Channel 0.

ADC CLK Control Register <11:0>

These bits control the ADC clocks and internal PLL clock.

<11>: Reserved. This bit must be written with Logic 0.

<10>: ADC Port CLK Invert Bit. When this bit is set, the inverted ADC port clock is used to register ADC input data into the part. When this bit is cleared, the clock is used as is, without any inversion or phase change.

<9>: Reserved. This bit must be written with Logic 0.

<8>: Reserved. This bit must be written with Logic 0.

<7:6>: ADC Pre PLL Clock Divider Bits.: These bits control the PLL clock divider. The PLL clock is derived from the ADC data port CLK.

Table 31. Divide-by Values for PLL Clock Divider Bits

PLL Clock Divider Bits <12:11>	Divide-by Value
00	Divide by 1, bypass
01	Divide by 2
10	Divide by 4
11	Divide by 8

<5:1>: PLL Clock Multiplier Bits. These bits control the PLL clock multiplier. The output of the PLL clock divider is multiplied with the binary value of these bits. Valid range for the multiplier is from 4 to 20. A value outside this range powers down the PLL, resulting in the PLL clock being the same as the ADC data port CLK.

<0>: This bit is open.

ADC Port Gain Control <7:0>

<7>: This bit is open.

<6:1>: This 6-bit word specifies the relinearization pipe delay to be used in the ADC input gain control block. The decimal representation of these bits is the number of input clock cycle pipeline delays between the external EXP data output and the internal application of relinearization based on EXP.

<0>: Gain Control Enable Bit. This bit controls the configuration of the EXP<2:0> bits for the ADC input port. When the gain control enable bit is Logic 1, the EXP<2:0> bits are configured as outputs. When this bit is cleared, the EXP<2:0> bits are inputs.

ADC Port Dwell Timer <19:0>

This register is used to set the dwell time for the gain control block. When the gain control block is active and detects a decrease in the signal level below the lower threshold value (programmable), a dwell-time counter is initiated to provide temporal hysteresis. Doing so prevents the gain from being continuously switched. Note that the dwell timer is turned on only after a drop below the lower threshold is detected in the signal level.

ADC Port Power Monitor Period <23:0>

This register is used in the power monitoring logic to set the period of time for which ADC input data is monitored. This value represents the monitor period in number of ADC port clock cycles.

ADC Port Power Monitor Output <23:0>

This register is read only and contains the current status of the power monitoring logic output. The output is dependent on the power monitoring mode selected. When the power monitor block is enabled, this register is updated at the end of each power monitor period. This register is updated even if an interrupt signal is not generated.

ADC Port Upper Threshold <9:0>

This register serves the dual purpose of specifying the upper threshold value in the gain control block and in the power monitoring block, depending on which block is active. ADC port input data having a magnitude greater than this value triggers a gain change in the gain control block. ADC port input data having a magnitude greater than this value is monitored in the power monitoring block (in peak detect or threshold crossing mode). The value of the register is compared with the absolute magnitude of the input port data.

ADC Port Lower Threshold <9:0>

This register is used in the gain control block and represents the magnitude of the lower threshold for ADC port input data. Any ADC input data having a magnitude below the lower threshold initiates the dwell time counter. The value of the register is compared with the absolute magnitude of the input port data.

ADC Port Signal Monitor <4:0>

This register controls the functions of the power monitoring block.

<4>: Disable Power Monitor Period Timer Bit. When this bit is set, the power monitor period timer no longer controls the update of the power monitor holding register. A user read to the power monitor holding register updates this register. When this bit is cleared, the power monitor period register controls the timer and, therefore, controls the update rate of the power monitor holding register.

<3>: Clear-on-Read Bit. When this bit is set, the power monitor holding register is cleared every time this register is read. This bit controls whether the power monitoring function is cleared after a read of the power monitor period register. If this bit is set, the monitoring function is cleared after the read. If this bit is Logic 0, the monitoring function is not cleared. This bit is a don't care bit, if the disable integration counter bit is cleared.

<2:1>: Monitor Function Select Bits. Table 32 describes the function of these bits.

Table 32. Monitor Function Select Bits

Monitor Function Select	Function Enabled
00	Peak detect mode
01	Mean power monitor mode
10	Threshold crossing mode
11	Invalid selection

<0>: Monitor Enable Bit. When this bit is set, the power monitoring function is enabled and operates as selected by Bit 2 to Bit 1 of the signal monitor register. When this bit is cleared, the power monitoring function is disabled and the signal monitor register bits <2:1> are don't care bits. These bits default to 0 on power-up.

CHANNEL REGISTER MAP

Channel control registers are common to all six channels, and access to specific channels is determined by the channel I/O access register (Address 0x02).

NCO Control <15:0>

These bits control the NCO operation.

<8:7>: NCO Sync Start Select Bits. These bits determine which SYNC input pin is used by this channel for a start synchronization operation. Table 33 describes the selection.

Table 33. Sync Start Select Bits

NCO Control <8:7>	SYNC Pin Used for Start Synchronization
00	SYNC0
01	SYNC1
10	SYNC2
11	SYNC3

<6:5>: NCO Sync Hop Select Bits. These bits determine which SYNC input pin is used by this channel for a hop synchronization operation. Table 34 describes the selection.

Table 34. Sync Hop Select Bits

NCO Control <6:5>	SYNC Pin Used for Hop Synchronization
00	SYNC0
01	SYNC1
10	SYNC2
11	SYNC3

<4>: This bit is open.

<3>: NCO Bypass Bit. When this bit is set, the NCO is bypassed and shuts down for power savings. This bit can be used for power savings, when NCO frequency of dc or 0 Hz is required. When this bit is cleared, the NCO operates as programmed.

<2>: Clear NCO Accumulator Bit. When this bit is set, the clear NCO accumulator bit synchronously clears the phase accumulator on all frequency hops in this channel. When this

bit is cleared, the accumulator is not cleared and phase continuous hops are implemented.

<1>: Phase Dither Enable Bit. When this bit is set, phase dithering in the NCO is enabled. When this bit is cleared, phase dithering is disabled.

<0>: Amplitude Dither Enable Bit. When this bit is set, amplitude dithering in the NCO is enabled. When this bit is cleared, amplitude dithering is disabled.

Channel Start Hold-Off Counter <15:0>

When a start synchronization (software or hardware) occurs on the channel, the value in this register is loaded into a down-counter. When the counter has finished counting down to 0, the channel operation is started.

NCO Frequency Hop Hold-Off Counter <15:0>

When a hop sync occurs, a counter is loaded with the NCO frequency hold-off register value. The 16-bit counter starts counting down. When it reaches 0, the new frequency value in the shadow register is written to the NCO frequency register. (See the NCO Frequency Hold-Off Register section.)

NCO Frequency <31:0>

The value in this register is used to program the NCO tuning frequency. The value to be programmed is given by the following equation:

$$\text{NCO Frequency Register} = \frac{\text{NCO_FREQUENCY}}{\text{CLK}} \times 2^{32}$$

where:

NCO_FREQUENCY is the desired NCO tuning frequency.
CLK is the ADC clock rate.

The value given by the equation should be loaded into the register in binary format.

NCO Phase Offset <15:0>

The value in the register is loaded into the phase accumulator of the NCO block every time a start sync or hop sync is received by the channel. This allows individual channels to be started with a known nonzero phase. The NCO phase offset is not loaded on a hop sync, if Bit <2> of the NCO control register (clear phase accumulator on hop) is cleared. This NCO offset register value is interpreted as a 16-bit unsigned integer. A 0x0000 in this register corresponds to a 0 radian offset, and a 0xFFFF corresponds to an offset of $2\pi (1 - 1/(2^{16}))$ radians.

CIC Bypass <0>

When this bit is set, the entire CIC filter is bypassed. The output of CIC filter is driven straight from the input without any change. When this bit is cleared, the CIC filter operates in normal mode as programmed. Writing Logic 1 to this bit disables both the CIC decimation and CIC scaling operations.

CIC Decimation <4:0>

This 5-bit word specifies the CIC filter decimation value minus 1. A value of 0x00 is a decimation of 1 (bypass), and 0x1F is a decimation of 32. Writing a value of 0 in this register bypasses CIC filtering, but does not bypass the CIC scaling operation.

CIC Scale Factor <4:0>

This 5-bit word specifies the CIC filter scale factor used to compensate for the gain provided by the CIC filter. The recommended value is given by the following equation:

$$\text{CIC Scale Register} = \text{ceil}(5 \times \log_2 (M_{CIC})) - 5$$

where:

M_{CIC} is the decimation rate of the CIC (one more than the value in the CIC decimation register).

ceil operation gives the closest integer greater than or equal to the argument.

The valid range for this register is decimal 0 to 20.

FIR-HB Control <3:0>

<3>: FIR1 Enable Bit. When this bit is set, the FIR1 fixed coefficient filter is enabled. When cleared, FIR1 is bypassed.

<2>: HB1 Enable Bit. When this bit is set, the HB1 half-band filter is enabled. When cleared, HB1 is bypassed.

<1>: FIR2 Enable Bit. When this bit is set, the FIR2 fixed coefficient filter is enabled. When cleared, FIR2 is bypassed.

<0>: HB2 Enable Bit. When this bit is set, the HB2 half-band filter is enabled. When cleared, HB2 is bypassed.

MRCF Control Register <12:0>

<12:10>: MRCF Data Select Bits. These bits are used to select the input source for the MRCF filter. Each MRCF filter can be driven by output from the HB2 filter of any channel independently. Table 35 shows the selections available.

Table 35. MRCF Data Select Bits

MRCF Data Select<2:0>	MRCF Input Source
000	MRCF input taken from Channel 0
001	MRCF input taken from Channel 1
010	MRCF input taken from Channel 2
011	MRCF input taken from Channel 3
1x0	MRCF input taken from Channel 4
1x1	MRCF input taken from Channel 5

<9>: Interpolating Half-Band Enable Bit. When this bit is set, the interpolating half-band filter, driven by the output of the CRCF block, is enabled. When cleared, the interpolating half-band filter is bypassed, and its output is the same as its input. The interpolating half-band filter doubles the data rate.

<8>: This bit is open.

<7>: Half-Rate Bit. When this bit is set, the MRCF filter operates using half the PLL clock rate. This is used for power savings when there is sufficient time to complete MRCF filtering using only half the PLL clock rate. When this bit is cleared, the MRCF filter operates at the full PLL clock rate. See the Mono-Rate RAM Coefficient Filter (MRCF) section.

<6:4>: MRCF Number of Taps Bits. This 3-bit word should be written with one less than the number of taps that are calculated by the MRCF filter. The filter length is given by the decimal value of this register plus 1. A value of 0 represents a 1-tap filter and maximum value of 7 represents an 8-tap filter.

<3:2>: MRCF Scale Factor Bits. The output of the MRCF filter is scaled according to the value of these bits. Table 36 describes the attenuation corresponding to each setting.

Table 36. MRCF Scale Factor

MRCF Scale<1:0>	Scale Factor
00	18.06 dB attenuation (left-shift 3 bits)
01	12.04 dB attenuation (left-shift 2 bits)
10	6.02 dB attenuation (left-shift 1 bit)
11	No scaling (0 dB)

<1>: This bit is open.

<0>: MRCF Bypass Bit. When this bit is set, the MRCF filter is bypassed and, therefore, the output of the MRCF is the same as its input. When this bit is cleared, the MRCF has normal operation as programmed by its control register.

MRCF COEFFICIENT MEMORY

The MRCF coefficient memory consists of eight coefficients, each six bits wide. The memory extends from Address 0x80 to Address 0x87. The coefficients should be written in twos complement format.

DRCF Control Register <11:0>

<11>: DRCF Bypass Bit. When this bit is set, the DRCF filter is bypassed and, therefore, its output is the same as its input. When this bit is cleared, the DRCF has normal operation as programmed by the rest of this control register.

<10>: Symmetry Bit. When this bit is set, it indicates that the DRCF is implementing a symmetrical filter and only half the impulse response needs to be written into the DRCF coefficient RAM. When this bit is cleared, the filter is asymmetrical and complete impulse response of the filter should be written to the coefficient RAM. When this filter is symmetrical, it can implement up to 128 filter taps.

<9:8>: DRCF Multiply Accumulate Scale Bits. The output of the DRCF filter is scaled according to the value of these bits. Table 37 lists the attenuation corresponding to each setting.

Table 37. DRCF Multiply Accumulate Scale Bits

DRCF Scale <1:0>	Scale Factor
00	18.06 dB attenuation (left-shift 3 bits)
01	12.04 dB attenuation (left-shift 2 bits)
10	6.02 dB attenuation (left-shift 1 bit)
11	No scaling (0 dB)

<7:4>: DRCF Decimation Rate. This 4-bit word should be written with one less than the decimation rate of the DRCF filter. A value of 0 represents a decimation rate of 1 (no rate change), and the maximum value of 15 represents a decimation of 16. Filtering can be implemented regardless of the decimation rate.

<3:0>: DRCF Decimation Phase Bits. This 4-bit word represents the decimation phase used by the DRCF filter. The valid range is 0 up to $M_{DRCF} - 1$, where M_{DRCF} is the decimation rate of the DRCF filter. This word is primarily used for synchronization of multiple channels of the AD6654, when more than one channel is used for filtering one signal (one carrier).

DRCF Coefficient Offset <7:0>

This register is used to specify which section of the 64-word coefficient memory is used for a filter. It can be used to select between multiple filters that are loaded into memory and referenced by this pointer. This register is shadowed, and the filter pointer is updated every time a new filter is started. This allows the coefficient offset to be written even while a filter is being computed without disturbing operation. The next sample comes out of the DRCF with the new filter.

DRCF Taps <6:0>

This register is written with one less than the number of taps that are calculated by the DRCF filter. The filter length is given by the decimal value of this register plus 1. A value of 0 represents a 1-tap filter, and a value of 0x28 (40 decimal) represents a 41-tap filter.

DRCF Start Address <5:0>

This register is written with the starting address of the DRCF coefficient memory to be updated.

DRCF Final Address <5:0>

This register is written with the ending address of the DRCF coefficient memory to be updated.

DRCF Coefficient Memory <13:0>

DRCF Memory. This memory consists of 64 words, and each word is 14 bits wide. The data written to this memory space is expected to be 14-bit, twos complement format. See the Decimating RAM Coefficient Filter (DRCF) section for the method to program the coefficients into the coefficient memory.

CRCF Control Register <11:0>

<11>: CRCF Bypass Bit. When this bit is set, the DRCF filter is bypassed and, therefore, its output is the same as its input. When this bit is cleared, the CRCF has normal operation as programmed by its control register.

<10>: Symmetry Bit. When this bit is set, it indicates that the CRCF is implementing a symmetrical filter and only half the impulse response needs to be written into the CRCF coefficient RAM. When this bit is cleared, the filter is asymmetrical and the complete impulse response of the filter should be written into the coefficient RAM. When this filter is symmetrical, it can implement up to 128 filter taps.

<9:8>: CRCF Multiply Accumulate Scale Bits. The output of the CRCF filter is scaled according to the value of these bits. Table 38 lists the attenuation corresponding to each setting.

Table 38. CRCF Multiply Accumulate Scale Bits

CRCF Scale <1:0>	Scale Factor
00	18.06 dB attenuation (left-shift 3 bits)
01	12.04 dB attenuation (left-shift 2 bits)
10	6.02 dB attenuation (left-shift 1 bit)
11	No scaling (0 dB)

<7:4>: CRCF Decimation Rate. This 4-bit word should be written with one less than the decimation rate of the CRCF filter. A value of 0 represents a decimation rate of 1 (no rate change) and the maximum value of 15 represents a decimation of 16. Filtering operation is done regardless of the decimation rate.

<3:0>: CRCF Decimation Phase. This 4-bit word represents the decimation phase used by the CRCF filter. The valid range is 0 to $M_{CRCF} - 1$, where M_{CRCF} is the decimation rate of the CRCF filter. This word is primarily used for synchronization of multiple channels of the AD6654, when more than one channel is used for filtering one signal (one carrier).

CRCF Coefficient Offset <5:0>

This register is used to specify which section of the 64-word coefficient memory is used for a filter. It can be used to select between multiple filters that are loaded into memory and referenced by this pointer. This register is shadowed, and the filter pointer is updated every time a new filter is started. This allows the coefficient offset to be written even while a filter is being computed without disturbing operation. The next sample comes out of the CRCF with the new filter.

CRCF Taps <6:0>

This register is written with one less than the number of taps that are calculated by the CRCF filter. The filter length is given by the decimal value of this register plus 1. A value of 0 represents a 1-tap filter, and a value of 0x28 (40 decimal) represents a 41-tap filter.

CRCF Coefficient Memory

CRCF Memory. This memory has 64 words that have 20 bits each. The memory contains the CRCF filter coefficients. The data written to this memory space is 20-bit in twos complement format. See the Channel RAM Coefficient Filter (CRCF) section for the method to program the coefficients into the coefficient memory.

AGC Control Register <10:0>

<10>: Channel Sync Select Bit. When this bit is set, the AGC uses the sync signal from the channel for its synchronization. When this bit is cleared, the SYNC pin used for synchronization is defined by Bit 9 to Bit 8 of this register.

<9:8>: SYNC Pin Select Bits. When Bit 10 of this register is cleared, these bits specify the SYNC pin used by AGC for synchronization. These bits don't care when Bit 10 of the AGC control register is set to Logic 1.

Table 39. SYNC Pin Select Bits

AGC Control Bits <9:8>	SYNC Pin Used by AGC
00	SYNC0
01	SYNC1
10	SYNC2
11	SYNC3

<7:5>: AGC Word Length Control Bits. These bits define the word length of the AGC output. The output word can be 4 to 8, 10, 12, or 16 bits wide. Table 40 shows the possible selections.

Table 40. AGC Word Length Control Bits

AGC Control Bits <7:5>	Output Word Length (Bits)
000	16
001	12
010	10
011	8
100	7
101	6
110	5
111	4

<4>: AGC Mode Bit. When this bit is cleared, the AGC operates to maintain a desired signal level. When this bit is set, it operates to maintain a constant clipping level. See the Automatic Gain Control section for details about these modes.

<3>: AGC Sync Now Bit. This bit is used to synchronize a particular AGC, regardless of the channel, through the programming ports (microport or serial port). When this bit is set, the AGC block updates a new output sample (RSSI sample) and starts working toward a new update sample.

<2>: Initialize on Sync Bit. This bit is used to determine whether or not the AGC should initialize on a sync. When this bit is set, during a synchronization the CIC filter is cleared and new values for CIC decimation, number of averaging samples, CIC scale, Signal Gain K, and the Pole P parameter are loaded.

When Bit 2 = 0, the above-mentioned parameters are not updated, and the CIC filter is not cleared. In both cases, an AGC update sample is output from the CIC filter and the decimator starts operating towards the next output sample whenever a sync occurs.

<1>: First Sync Only. This bit is used to ignore repetitive synchronization signals. In some applications, the synchronization signal occurs periodically. If this bit is cleared, each synchronization request resynchronizes the AGC. If this bit is set, only the first occurrence causes the AGC to synchronize and updates the AGC gain values periodically, depending on the decimation factor of the AGC CIC filter.

<0>: AGC Bypass Bit. When this bit is set, the AGC section is bypassed. The N-bit representation from the interpolating half-band filters is still reduced to a lower bit width representation as set by Bit 7 to Bit 5 of the AGC control register. A truncation at the output of the AGC accomplishes this task.

AGC Hold-Off Register <15:0>

The AGC hold-off counter is loaded with the value written to this address when either a soft sync or pin sync comes into the channel. The counter begins counting down. When it reaches 1, a sync is sent to the AGC. This sync might or might not initialize the AGC, as defined by the control word. The AGC loop is updated with a new sample from the CIC filter whenever a sync occurs. If this register is Logic 1, the AGC is immediately updated when the sync occurs. If this register is Logic 0, the AGC cannot be synchronized.

AGC Update Decimation <11:0>

This 12-bit register sets the AGC decimation ratio from 1 to 4096. An appropriate scaling factor should be set to avoid loss of bits. The decimation ratio is given by the decimal value of the AGC update decimation <11:0> register contents plus 1, that is, 12'0x000 describes a decimation ratio of 1, and 12'0xFFFF describes a decimation ratio of 4096.

AGC Signal Gain <11:0>

This register is used to set the initial value for a signal gain used in the gain multiplier. This 12-bit value sets the initial signal gain in the range of 0 dB and 96.296 dB in steps of 0.024 dB. Initial signal gain (SG) in dB should be converted to a register setting using the following formula:

$$\text{Register Value} = \text{round} \left[\frac{\text{SG}}{20 \log_{10}(2)} \times 256 \right]$$

AGC Error Threshold <11:0>

This 12-bit register is the comparison value used to determine which loop gain value (K_1 or K_2) to use for optimum operation. When the magnitude-of-error signal is less than the AGC error threshold value, then K_1 is used; otherwise, K_2 is used. The word

format of the AGC error threshold register is four bits to the left of the binary point and eight bits to the right.

See the Automatic Gain Control section for details.

$$\text{Register Value} = \text{round} \left[\frac{\text{Error Threshold}}{20 \log_{10} (2)} \right] \times 256$$

AGC Average Samples <5:0>

This 6-bit register contains the scale used for the CIC filter and the number of power samples to be averaged before being sent to the CIC filter.

<5:2>: CIC Scale. This 4-bit word defines the scale used for the CIC filter. Each increment of this word increases the CIC scale by 6.02 dB.

<1:0>: Number of AGC Average Samples. This defines the number of samples to be averaged before they are sent to the CIC decimating filter. See Table 41.

Table 41. Number of AGC Average Samples

AGC Average Samples <1:0>	Number of Samples Taken
00	1
01	2
10	3
11	4

AGC Pole Location <7:0>

This 8-bit register is used to define P, the open-loop filter pole location. Its value can be set from 0 to 0.996 in steps of 0.0039. This value of P is updated in the AGC loop each time the AGC is initialized. This open-loop pole location directly impacts the closed-loop pole locations, as explained in the Automatic Gain Control section.

AGC Desired Level <7:0>

This register contains the desired signal level or desired clipping level, depending on operational mode. This desired request level (R) can be set in dB from 0 to 23.99 in steps of 0.094 dB. The request level (R) in dB should be converted to a register setting using the following formula:

$$\text{Register Value} = \text{round} \left[\frac{R}{20 \log_{10} (2)} \times 64 \right]$$

AGC Loop Gain 2 <7:0>

This 8-bit register is used to define K₂, the second possible open-loop gain. Its value can be set from 0 to 0.996 in steps of 0.0039. This value of K₂ is updated each time the AGC is initialized. When the magnitude-of-error signal in the loop is greater than the AGC error threshold, then K₂ is used by the loop. K₂ is updated only when the AGC is initialized.

AGC Loop Gain 1 <7:0>

This 8-bit register is used to define K₁, the open-loop gain. Its value can be set from 0 to 0.996 in steps of 0.0039. This value of K is updated in the AGC loop each time the AGC is initialized. When the magnitude-of-error signal in the loop is less than the AGC error threshold, then K₁ is used by the loop. K₁ is updated only when the AGC is initialized.

I Path Signature Register <15:0>

This 16-bit signature register is for the I path of the channel logic. The signature register records data on the networks that leave the channel logic, just before entering the second data router.

Q Path Signature Register <15:0>

This 16-bit signature register is for the Q path of the channel logic. The signature register records data on the networks that leave the channel logic, just before entering the second data router.

BIST Control <15:0>

<15>: Disable Signature Generation Bit. When this bit is active high, the signature registers do not produce a pseudorandom output value, but instead directly load the 24-bit input data. When this bit is cleared, the signature register produces a pseudorandom output for every clock cycle that it is active. See the User-Configurable Built-In Self-Test (BIST) section for details.

<14:0>: BIST Timer Bits. The <14:0> bits of this register form a 15-bit word that is loaded into the BIST timer. After loading the BIST timer, the signature register is enabled for operation while the timer is actively counting down. See the User-Configurable Built-In Self-Test (BIST) section for details.

OUTPUT PORT REGISTER MAP

This part of the memory map deals with the output data and controls for parallel output ports.

Parallel Port Output Control <23:0>

<23>: Port C Append RSSI Bit. When this bit is set, an RSSI word is appended to every I/Q output sample, regardless of whether the RSSI word is updated in the AGC. When this bit is cleared, an RSSI word is appended to an I/Q output sample only when the RSSI word is updated. The RSSI word is not output for subsequent I/Q samples until the next time the RSSI is updated in the AGC.

<22>: Port C, Data Format Bit. When this bit is set, the port is configured for 8-bit parallel I/Q mode. When cleared, the port is configured for 16-bit interleaved I/Q mode. See the Parallel Port Output section for details.

<21>: Port C, AGC5 Enable Bit. When this bit is set, AGC5 data (I/Q data) is output on parallel Output Port C (data bus).

When this bit is cleared, AGC5 data does not appear on Output Port C.

<20>: Port C, AGC4 Enable Bit. Similar to Bit 21 for AGC4.

<19>: Port C, AGC3 Enable Bit. Similar to Bit 21 for AGC3.

<18>: Port C, AGC2 Enable Bit. Similar to Bit 21 for AGC2.

<17>: Port C, AGC1 Enable Bit. Similar to Bit 21 for AGC1.

<16>: Port C, AGC0 Enable Bit. Similar to Bit 21 for AGC0.

<15>: Port B Append RSSI Bit. When this bit is set, an RSSI word is appended to every I/Q output sample, regardless of whether the RSSI word is updated in the AGC. When this bit is cleared, an RSSI word is appended to an I/Q output sample only when the RSSI word is updated. The RSSI word is not output for subsequent I/Q samples until the next time the RSSI is updated in the AGC.

<14>: Port B, Data Format Bit. When this bit is set, the port is configured for 8-bit parallel I/Q mode. When this bit is cleared, the port is configured for 16-bit interleaved I/Q mode. See the Parallel Port Output section.

<13>: Port B, AGC5 Enable Bit. When this bit is set, AGC5 data (I/Q data) is output on Parallel Output Port A (data bus). When this bit is cleared, AGC5 data does not appear on Output Port C.

<12>: Port B, AGC4 Enable Bit. Similar to Bit 13 for AGC4.

<11>: Port B, AGC3 Enable Bit. Similar to Bit 13 for AGC3.

<10>: Port B, AGC2 Enable Bit. Similar to Bit 13 for AGC2.

<9>: Port B, AGC1 Enable Bit. Similar to Bit 13 for AGC1.

<8>: Port B, AGC0 Enable Bit. Similar to Bit 13 for AGC0.

<7>: Port A Appended RSSI Bit. When this bit is set, an RSSI word is append to every I/Q output sample, regardless of whether the RSSI word is updated in the AGC. When this bit is cleared, an RSSI word is appended to an I/Q output sample only when the RSSI word is updated. The RSSI word is not output for subsequent I/Q samples until the next time RSSI is updated again in the AGC.

<6>: Port A, Data Format Bit. When this bit is set, the port is configured for 8-bit parallel I/Q mode. When this bit is cleared, the port is configured for 16-bit interleaved I/Q mode. See the Parallel Port Output section.

<5>: Port A, AGC5 Enable Bit. When this bit is set, AGC5 data (I/Q data) is output on parallel output Port A (data bus). When this bit is cleared, AGC5 data does not appear on output Port C.

<4>: Port A, AGC4 Enable Bit. Similar to Bit 5 for AGC4.

<3>: Port A, AGC3 Enable Bit. Similar to Bit 5 for AGC3.

<2>: Port A, AGC2 Enable Bit. Similar to Bit 5 for AGC2.

<1>: Port A, AGC1 Enable Bit. Similar to Bit 5 for AGC1.

<0>: Port A, AGC0 Enable Bit. Similar to Bit 5 for AGC0.

Output Port Control <9:0>

<9:8>: PCLK Divisor Bits. When a parallel port is in master mode, the PCLK is derived from the PLL_CLK. These bits define the value of the divisor used to divide the PLL_CLK to obtain the PCLK. These bits are don't care in slave mode.

Table 42. PCLK Divisor Bits

PCLK Divisor <7:6>	Divisor Value
00	1
01	2
10	4
11	8

<7>: PCLK Master Mode Bit. When the PCLK master mode bit is set, the PCLK pin is configured as an output and the PCLK is driven by the PLL_CLK. Data is transferred out of the AD6654 synchronous to this output clock. When this bit is cleared, the PCLK pin is configured as an input. The user is required to provide a PCLK, and data is transferred out of the AD6654 synchronous to this input clock. On power-up, this bit is cleared to avoid contention on the PCLK pin.

<6:4>: Reserved. These bits must be written with Logic 0.

<3:0>: Stream Control Bits. These bits are described in Table 43.

Table 43. Stream Control Bits

Stream Control Bits	Output Streams (str0, str1, str2, str3, str4, str5)	Number of Streams
0000	Ch 0 and Ch 1 combined; Ch 2, Ch 3, Ch 4, Ch 5 independent	5
0001	Ch 0, Ch 1, Ch 2 combined; Ch 3, Ch 4, Ch 5 independent	4
0010	Ch 0, Ch 1, Ch 2, Ch 3 combined; Ch 4, Ch 5 independent	3
0011	Ch 0, Ch 1, Ch 2, Ch 3, Ch 4 combined; Ch 5 independent	2
0100	Ch 0, Ch 1, Ch 2, Ch 3, Ch 4, Ch 5 combined	1
0101	Ch 0, Ch 1, Ch 2 combined; Ch 3, Ch 4, Ch 5 combined	2
0110	Ch 0, Ch 1 combined; Ch 2, Ch 3 combined; Ch 4, Ch 5 combined	3
0111	Ch 0, Ch 1 combined; Ch 2, Ch 3 combined; Ch 4, Ch 5 independent	4
1000	Ch 0, Ch 1, Ch 2 combined; Ch 3, Ch 4 combined; Ch 5 independent	3
1001	Ch 0, Ch 1, Ch 2, Ch 3 combined; Ch 4, Ch 5 combined.	2
Default	Independent channels	6

AGC0, I Output <15:0>

This read-only register provides the latest in-phase output sample from AGC0. Note that AGC0 might be bypassed, and that AGC0 here is representative of the datapath only.

AGC0, Q Output <15:0>

This read-only register provides the latest quadrature-phase output sample from AGC0. Note that AGC0 might be bypassed, and that AGC0 here is representative of the datapath only.

AGC1, I Output <15:0>

This read-only register provides the latest in-phase output sample from AGC1. Note that AGC1 might be bypassed and that AGC1 here is representative of the datapath only.

AGC1, Q Output <15:0>

This read-only register provides the latest quadrature-phase output sample from AGC1. Note that AGC1 might be bypassed and that AGC1 here is representative of the datapath only.

AGC2, I Output <15:0>

This read-only register provides the latest in-phase output sample from AGC2. Note that AGC2 might be bypassed and that AGC2 here is representative of the datapath only.

AGC2, Q Output <15:0>

This read-only register provides the latest quadrature-phase output sample from AGC2. Note that AGC2 might be bypassed and that AGC2 here is representative of the datapath only.

AGC3, I Output <15:0>

This read-only register provides the latest in-phase output sample from AGC3. Note that AGC3 might be bypassed and that AGC3 here is representative of the datapath only.

AGC3, Q Output <15:0>

This read-only register provides the latest quadrature-phase output sample from AGC3. Note that AGC3 might be bypassed and that AGC3 here is representative of the datapath only.

AGC4, I Output <15:0>

This read-only register provides the latest in-phase output sample from AGC4. Note that AGC4 might be bypassed and that AGC4 here is representative of the datapath only.

AGC4, Q Output <15:0>

This read-only register provides the latest quadrature-phase output sample from AGC4. Note that AGC4 might be bypassed and that AGC4 here is representative of the datapath only.

AGC5, I Output <15:0>

This read-only register provides the latest in-phase output sample from AGC5. Note that AGC5 might be bypassed and that AGC5 here is representative of the datapath only.

AGC5, Q Output <15:0>

This read-only register provides the latest quadrature-phase output sample from AGC5. Note that AGC5 might be bypassed and that AGC5 here is representative of the datapath only.

AGC0, RSSI Output <11:0>

This read-only register provides the latest RSSI output sample from AGC0. This register is updated only when AGC0 is enabled and operating.

AGC1, RSSI Output <11:0>

This read-only register provides the latest RSSI output sample from AGC1. This register is updated only when AGC1 is enabled and operating.

AGC2, RSSI Output <11:0>

This read-only register provides the latest RSSI output sample from AGC2. This register is updated only when AGC2 is enabled and operating.

AGC3, RSSI Output <11:0>

This read-only register provides the latest RSSI output sample from AGC3. This register is updated only when AGC3 is enabled and operating.

AGC4, RSSI Output <11:0>

This read-only register provides the latest RSSI output sample from AGC4. This register is updated only when AGC4 is enabled and operating.

AGC5, RSSI Output <11:0>

This read-only register provides the latest RSSI output sample from AGC5. This register is updated only when AGC5 is enabled and operating.

DDC DESIGN NOTES

The following guidelines describe circuit connections, layout requirements, and programming procedures for the AD6654. The designer should review these guidelines before starting the system design and layout.

- The AD6654 requires the following power-up sequence. The VDDCORE (1.8 V) is required to settle into nominal voltage levels before the VDDIO attains the minimum.
- The DDC input clock (CLK) and input (EXP) pins EXP[2:0] are not 5 V tolerant. Care should be taken to drive these pins within the limits of VDDIO (3.0 V to 3.6 V). This is easily accomplished by using the ADC data ready (DR) output to drive the DDC clock (CLK) input.
- The number format used in this part is twos complement. All input ports and output ports use twos complement data format. The formats for individual internal registers are given in the memory map description of these registers.
- In both microport and serial port operation, the $\overline{\text{DTACK}}$ (RDY, SDO) and $\overline{\text{IRP}}$ pins are open-drain outputs and should be terminated externally to VDDIO through a 1 k Ω pull-up resistor.

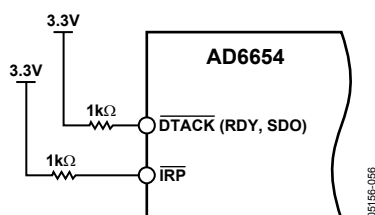

Figure 75. $\overline{\text{DTACK}}$, $\overline{\text{SDO}}$, $\overline{\text{IRP}}$ Pull-Up Resistor Circuit

- A simple RC circuit is used on the EXT_FILTER pin to balance the internal RC circuit on this pin and maintain a good PLL clock lock. The recommended circuit is given in Figure 76. It is further recommended that this RC circuit be placed as close as possible to the AD6654 part. This layout consideration ensures that the PLL clock is clean and the PLL lock is closely maintained.

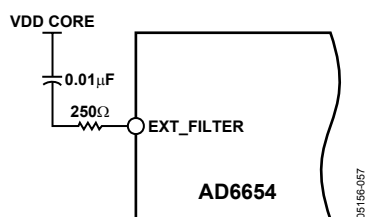

Figure 76. EXT_FILTER Circuit for PLL Clock

- By default, the PLL CLK is disabled. It can be enabled by programming the PLL multiplier and divider bits in the ADC CLK control register. When the PLL CLK is enabled by programming this register, it takes about 50 μs to 200 μs to settle down. While the PLL loop settles down, the voltage at the EXT_FILTER pin increases from 0 V to VDDCORE (1.8 V) and settles there. Channel registers and output port registers (Address 0x68 to Address 0xE7) should not be programmed before the PLL loop settles down.
- To reset the AD6654, the user must provide a minimum pulse of 30 ns to the $\overline{\text{RESET}}$ pin. The $\overline{\text{RESET}}$ pin should be connected to GND (or pulled low) during power-up of the part. The $\overline{\text{RESET}}$ pin can be pulled high after the power supplies have settled to nominal values (1.8 V and 3.3 V). At this point, a pulse (pull low and high again) should be provided to give a reset to the part.
- The CPUCLK (SCLK) is the clock used for programming via the microport (serial port). This clock needs to be provided by the designer to the part (slave clock). The designer should ensure that this clock's frequency is less than or equal to the frequency of the CLK signal. Additionally, the frequency of the CPUCLK (SCLK) should always be less than 100 MHz.
- The microport data bus is 16 bits wide. Both 8-bit and 16-bit modes are available using this part. If 8-bit mode is used, the MSB of the data bus (D[15:8]) can be left floating or connected to GND.
- The output parallel port has a 1-clock cycle overhead. If two channels (with the same data rates) are output on one output port in 16-bit interleaved I/Q mode along with an AGC word, this requires three clock cycles for one sample from each channel (one clock each for I data, Q data, and gain data). Therefore, the total number of clock cycles required to output the data is 3 clocks/channel \times 2 channels + 1 (overhead) = 7 clock cycles. The number of clock cycles required for each channel can be 3 (interleaved I + Q + gain word), or 2 (parallel I /Q + gain) or 2 (interleaved I + Q) or 1 (interleaved I/Q). Designers should make sure that sufficient time is allowed to output these channels on one output port. Also note that the I, Q, and gain for a particular channel come out on a single output port and cannot be divided among output ports.
- When CRCF and DRCF filters are disabled, the coefficient memory cannot be read back, because the clock to the coefficient RAM is also cut off.

AD6654

- In the Intel mode microport, the beginning of a read and write access is indicated by the RDY pin going low. The access is complete only when the RDY pin goes high. In the Motorola mode microport, the completion of a read and write access is indicated by the $\overline{\text{DTACK}}$ pin going low. In both modes, $\overline{\text{CS}}$, $\overline{\text{RD}}$ ($\overline{\text{DS}}$), and $\overline{\text{WR}}$ ($\overline{\text{R/W}}$) should be active until access is complete; otherwise, an incomplete access results.
- In both Intel and Motorola modes, if $\overline{\text{CS}}$ is held low even after microport read or write access is complete, the microport initiates a second access. This is a problem while writing or reading from coefficient RAM, where each access writes to or reads from a different RAM address. This can be fixed by writing to one coefficient RAM address at a time, that is, the coefficient start and stop address registers have the same value.
- In SPI mode programming, the $\overline{\text{SCS}}$ pin must go high (inactive) after writing or reading each byte (eight clock cycles on the SCLK pin).

OUTLINE DIMENSIONS

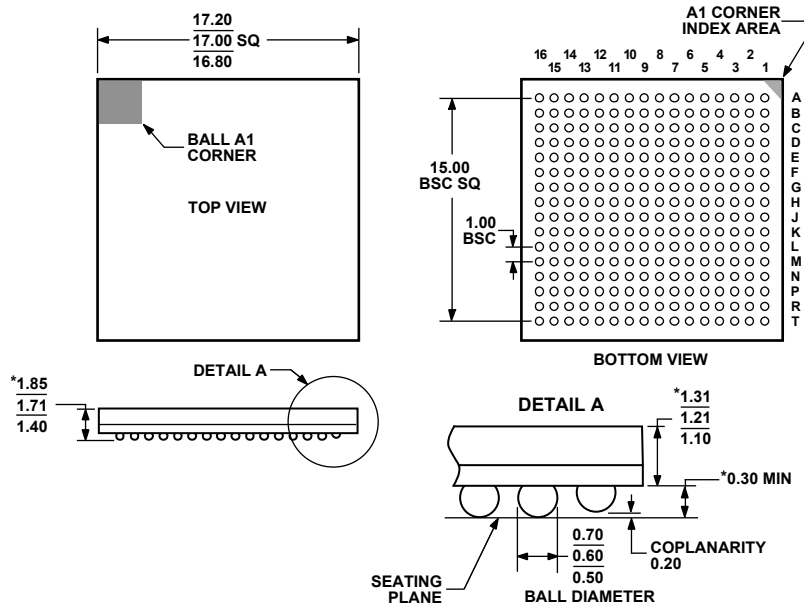

COMPLIANT TO JEDEC STANDARDS MO-192-AAF-1
EXCEPT FOR DIMENSIONS INDICATED BY A "*" SYMBOL.

Figure 77. 256-Lead Chip Scale Package Ball Grid Array [CSPBGA]
(BC-256-2)
Dimensions shown in millimeters

ORDERING GUIDE

Model	Temperature Range	Active Channels	Package Description	Package Option
AD6654BBC	-25°C to +85°C	6	256-Lead CSPBGA (Ball Grid Array)	BC-256-2
AD6654BBCZ ¹	-25°C to +85°C	6	256-Lead CSPBGA (Ball Grid Array)	BC-256-2
AD6654CBC	-25°C to +85°C	4	256-Lead CSPBGA (Ball Grid Array)	BC-256-2
AD6654CBCZ ¹	-25°C to +85°C	4	256-Lead CSPBGA (Ball Grid Array)	BC-256-2
AD6654/PCB		6	Evaluation Board with AD6654 and Software	

¹ Z = Pb-free part.

AD6654

NOTES

