

AFBR-15x9Z

DC to 10 Mbd Versatile Link Fiber Optic
Analog Transmitter for 1 mm POF and 200 μm PCS

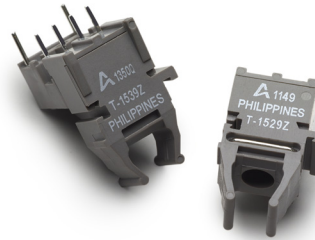

Data Sheet



Description

The AFBR-15x9Z analog transmitter utilizes a 650 nm LED source in a housing designed to efficiently couple into 1 mm Polymer Optical Fiber (POF) and 200 μm diameter Plastic-Clad Silica (PCS). Links up to 50 m are supported with 1 mm POF, and up to 200 m with 200 μm PCS. It is designed to interoperate with Avago’s HFBR-25xxZ, AFBR-25xxZ and AFBR-26xxZ receivers.

The transmitter is a 4-pin device, packed in Versatile Link housing. Versatile Link components can be interlocked (N-plexed together) to minimize space and to provide dual connections with the duplex connectors. Various simplex and duplex connectors, as well as POF cables are available for Versatile Link components. Please contact Avago Technologies for details or visit our company website at www.avagotech.com

AFBR-15x9Z - Part number selection guide

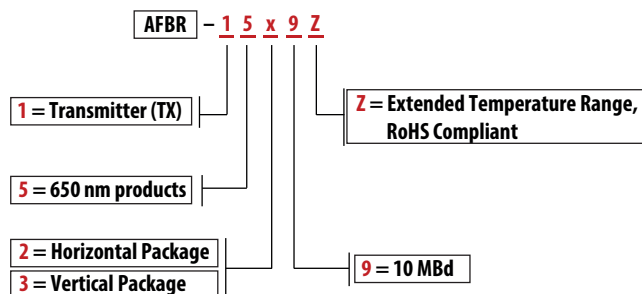

Available options

Horizontal Package	AFBR-1529Z
Vertical Package	AFBR-1539Z

Features

- RoHS-compliant
- Data transmission at signal rates from DC up to 10 MBd
- Up to 50 meters distance with 1 mm Polymer Optical Fiber (POF) and 200 meters with 200 μm PCS
- Operating temperature range of -40 °C to +85 °C
- Compatible with Avago’s Versatile Link family of connectors, for easy termination of fiber

Applications

- Industrial control and factory automation
- Serial field buses
- Intra-system links; Board-to-Board, Rack-to-Rack
- Extension of RS-232 and RS-485
- High voltage isolation
- Elimination of ground loops
- Reduces voltage transient susceptibility

Package and Handling Information

Versatile Link packages are made of a flame-retardant material and use the same pad layout as a standard, eight-pin dual-in-line package. Versatile Link packages are stackable and are enclosed to provide a dust-resistant seal. Snap action simplex, simplex latching, duplex, and duplex latching connectors are offered with simplex or duplex cables.

Package Housing Color

Versatile Link components and simplex connectors are color-coded to eliminate confusion when making connections. Transmitters are gray.

Handling

Versatile Link components are auto-insertable. When wave soldering is performed with Versatile Link components, the optical port plug should be left in to prevent contamination of the port. Do not use reflow solder processes (i.e., infrared reflow or vapor-phase reflow). Non-halogenated water-soluble fluxes (i.e., 0% chloride), not rosin-based fluxes, are recommended for use with Versatile Link components.

Versatile Link components are moisture-sensitive devices and are shipped in a moisture-sealed bag. If the components are exposed to air for an extended period of time, they may require a baking step before the soldering process. Refer to the special labeling on the shipping tube for details.

Mechanical Dimensions

Horizontal Module

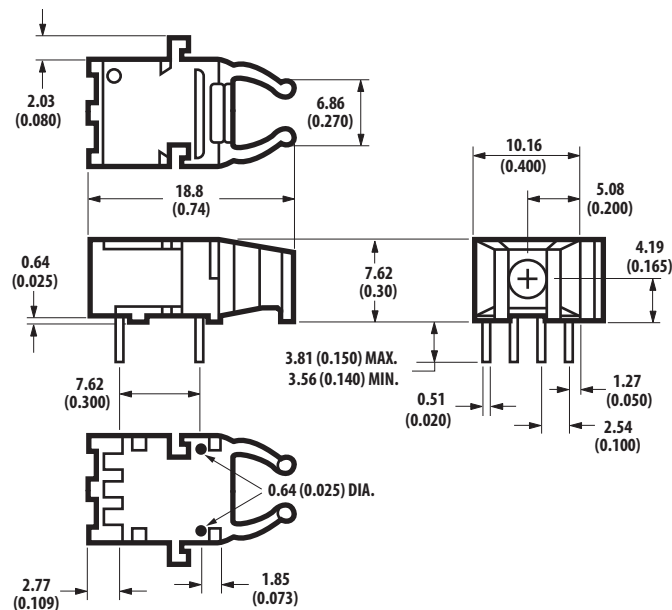

DIMENSIONS IN MILLIMETERS (INCHES)

Vertical Module

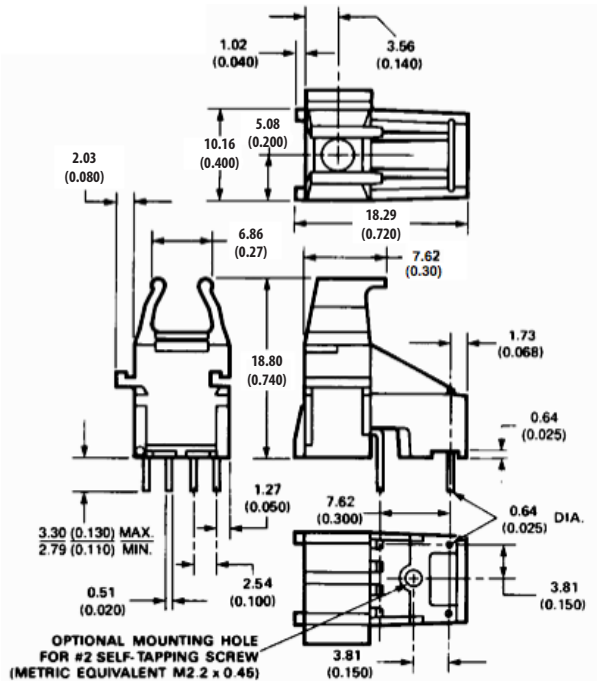

Versatile Link Printed Board Layout Dimensions

Horizontal Module

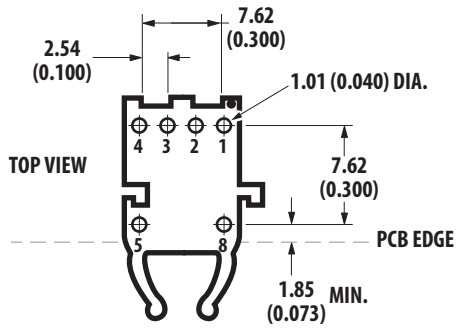

DIMENSIONS IN MILLIMETERS (INCHES).

Vertical Module

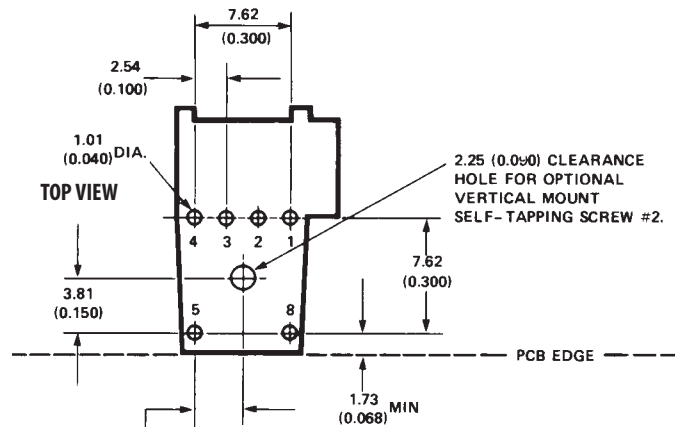

DIMENSIONS IN MILLIMETERS AND (INCHES)

Interlocked (Stacked) Assemblies

Horizontal packages may be stacked by placing units with pins facing upward. Initially engage the interlocking mechanism by sliding the L bracket body from above into the L slot body of the lower package. Use a straight edge, such as a ruler, to bring all stacked units into uniform alignment. This technique prevents potential harm that could occur to fingers and hands of assemblers from the package pins. Stacked horizontal

packages can be disengaged if necessary. Repeated stacking and unstacking causes no damage to individual units.

To stack vertical packages, hold one unit in each hand, with the pins facing away and the optical ports on the bottom. Slide the L bracket unit into the L slot unit. The straight edge used for horizontal package alignment is not needed.

Stacking Horizontal Modules

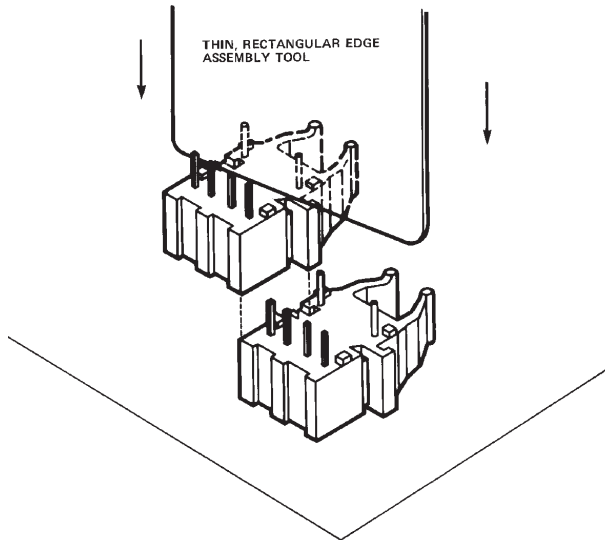

Stacking Vertical Modules

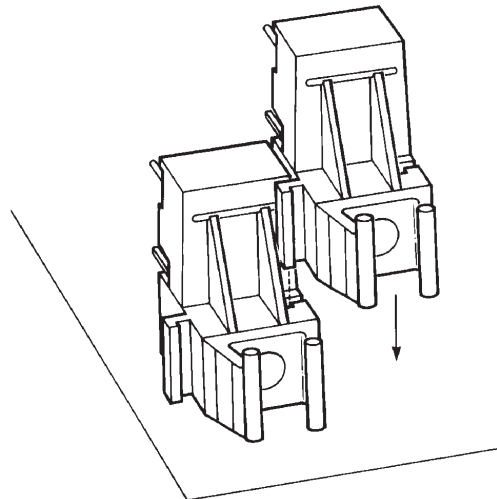

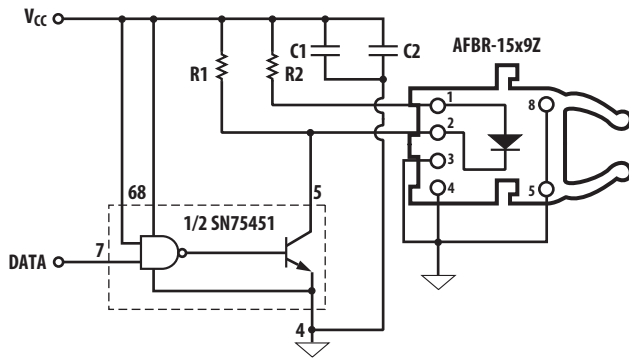

Note:
This is an inverting circuitry, thus the LED is off in case of DATA "H". Therefore, an inverting receiver, e.g. AFBR-2529Z, should be used accordingly.

	Value	Tolerance
R1	2 kΩ	5%
R2	100 Ω	1%
C1	0.1 μF	20%
C2	10 μF	20%

Figure 1. Recommended drive circuit Top View

($I_{F,on} = 30 \text{ mA}$ nominal at $T_A = 25 \text{ }^\circ\text{C}$)

Pin Description Transmitter

Fiber port facing front, pins downward,
1 = Rightmost pin to 4 = Leftmost pin

Pin	Name	Function/Description	Notes
1	Anode	LED Anode	
2	Cathode	LED Cathode	
3	Pin	No function, physical pin available, recommended to signal GND	
4	Pin	No function, physical pin available, recommended to signal GND	
5	Housing Pin	Physical pin available, recommended to chassis GND	1
8	Housing Pin	Physical pin available, recommended to chassis GND	1

Regulatory Compliance

Feature	Test Method	Performance
Electrostatic Discharge (ESD) to the Electrical Pins Human Body Model	MIL-STD-883 Method 3015	Min ± 2000 V
Eye Safety	IEC 60825-1,2 ,Class 1	Class 1

Specified Link Performance, $T_A = -40 \text{ }^\circ\text{C}$ to $+85 \text{ }^\circ\text{C}$, 10 MBd

Parameter	Min	Max	Unit	Condition	Note
Link Distance with Standard Loss POF cable	0.1	50	m	$-40 \text{ }^\circ\text{C}$ to $+85 \text{ }^\circ\text{C}$	2
Link Distance with 200 μm PCS cable	0.1	200	m	$-40 \text{ }^\circ\text{C}$ to $+85 \text{ }^\circ\text{C}$	3

Notes:

1. Pins 5 and 8 are for mounting and retaining purposes. Make sure they are electrically connected to Chassis GND.
2. POF is HFBR-R/EXXXXXZ plastic (1 mm) optical fiber. Worst-case attenuation used (0.27 dB/m for standard loss POF cable from $-40 \text{ }^\circ\text{C}$ to $+85 \text{ }^\circ\text{C}$ at 650 nm). Link performance is valid in combination with AFBR-26x4Z and AFBR-25x9Z.
3. PCS, worst-case attenuation (12 dB/km from $-40 \text{ }^\circ\text{C}$ to $+85 \text{ }^\circ\text{C}$ at 650 nm).

Absolute Maximum Ratings

Parameter	Symbol	Min	Max	Unit	Notes
Storage and Operating Temperature	$T_{S,O}$	-40	85	°C	
Transmitter Peaking Forward Input Current	$I_{F,PK}$		45	mA	1
Transmitter Short Term Peaking Forward Input Current	$I_{F,PKshort}$		80	mA	2
Transmitter Average Forward Input Current	$I_{F,AVG}$		30	mA	
Transmitter Reverse Input Voltage	V_R		3	V	

Notes:

1. For $I_{F,PK} > 30$ mA the duty factor must maintain ≤ 30 mA $I_{F,AVG}$ and pulse width ≤ 1 μ s
2. Maximum short term peaking forward current must not longer be applied than 5 ns to improve rise time or enhance signaling rate. Applying a short term peaking forward current shall not result in exceeding 30 mA average forward current.

Recommended Operating Conditions

Parameter	Symbol	Min	Max	Unit	Notes
Ambient Temperature, no air flow	T_A	-40	85	°C	1, 2
Transmitter Average Forward Input Current	$I_{F,AVG}$	3	30	mA	
Signaling Rate	f_s	DC	10	Mbd	3

Notes:

1. Recommended operating conditions are those values outside of which functional performance is not intended, device reliability is not implied, and damage to the device may occur over an extended period of time. See Reliability Data Sheet for specific reliability performance.
2. Measured at the housing.
3. Without peaking of the electrical input signal

Process Compatibility

Parameter	Symbol	Min	Typical	Max	Unit	Notes
Solder Environment	T_{SOLD}			260	°C	1, 3, 4
	t_{SOLD}			10	sec	2, 3, 4

Notes:

1. Maximum temperature refers to peak temperature.
2. Maximum time refers to time spent at peak temperature.
3. Solder surface to be at least 1 mm below lead frame stops.
4. Product is Moisture Sensitive Level 3.

AFBR-15x9Z analog Transmitter

The AFBR-15x9Z analog transmitter utilizes a 650 nm LED source in a housing designed to efficiently couple into 1 mm Polymer Optical Fiber (POF) or 200 μm Plastic-Clad Silica (PCS). Links up to 50 meters are supported with 1 mm POF. Links up to 200 meters are supported with 200 μm PCS.

Electrical and Optical Characteristics

($T_A = -40^\circ\text{C}$ to $+85^\circ\text{C}$ unless otherwise stated)

Parameter	Symbol	Min	Typical	Max	Unit	Conditions	Notes
Peak Output Power, 1 mm POF, 30 mA	P_T	-6	-1	2	dBm	$I_{F,DC} = 30\text{ mA}$	1, 2
Peak Output Power, 200 μm PCS, 30 mA	P_T	-18	-12	-9	dBm	$I_{F,DC} = 30\text{ mA}$	1, 2
Peak Output Power, 1 mm POF, 10 mA	P_T	-11	-6	-3	dBm	$I_{F,DC} = 10\text{ mA}$	1, 2
Peak Output Power, 1 mm POF, 5 mA	P_T	-14	-9	-6	dBm	$I_{F,DC} = 5\text{ mA}$	1, 2
Peak Output Power, 1 mm POF, 3 mA	P_T	-16	-11	-8	dBm	$I_{F,DC} = 3\text{ mA}$	1, 2
Optical Power Temperature Coefficient	$\Delta P_T/\Delta T$		-0.01		dB/K	$-40^\circ\text{C} \dots +25^\circ\text{C}$	
Optical Power Temperature Coefficient	$\Delta P_T/\Delta T$		-0.02		dB/K	$+25^\circ\text{C} \dots +85^\circ\text{C}$	
Peak emission wavelength	λ_p	630	650	685	nm		
Peak Emission wavelength Temperature coefficient	$\Delta\lambda/\Delta T$		0.16		nm/K		
Spectral Width	FWHM		20		nm		
Forward Voltage	V_F	1.4		2.3	V	$I_{F,DC} = 3\text{ mA to }30\text{ mA}$	
Forward Voltage temperature coefficient	$\Delta V_F/\Delta T$		1.6		mV/K	$I_{F,DC} = 30\text{ mA}$	
Reverse Input Breakdown voltage		9	20		V		
Diode Capacitance			30	70	pF		
Optical Rise time	t_r			30	ns	20% to 80%	3
Optical Fall time	t_f			30	ns	80% to 20%	3

Notes:

- Optical power measured with polished connector end face at the end of 0.5 meters of 1 mm diameter POF with a numerical aperture (NA) of 0.5, or of 200 μm diameter PCS, with NA=0.37.
- Minimum average output power specification value includes 1dB degradation margin.
- Using recommended drive circuit in Figure 1 for $I_{F,DC} = 30\text{mA}$

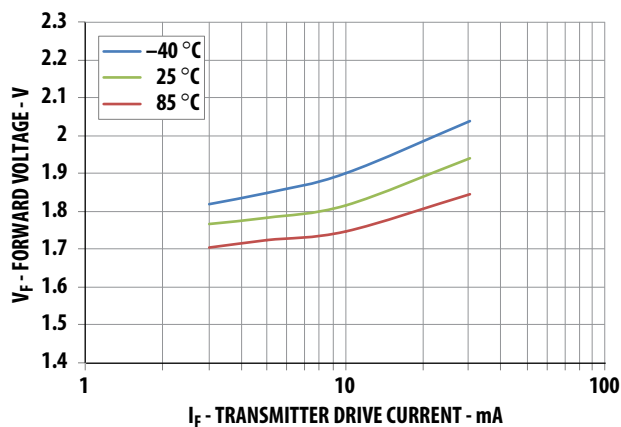

Figure 2. Typical forward voltage vs. drive current

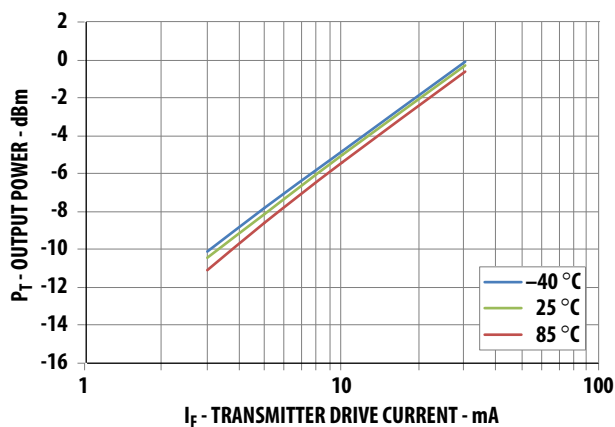

Figure 3. Typical optical output power vs. drive current

For product information and a complete list of distributors, please go to our web site: www.avagotech.com

Avago, Avago Technologies, and the A logo are trademarks of Avago Technologies in the United States and other countries. Data subject to change. Copyright © 2005-2015 Avago Technologies. All rights reserved. AV02-4367EN - April 13, 2015

AVAGO
TECHNOLOGIES