

QJ—12031F-0—2007

SPECIFICATION

OF PRODUCTS

CUSTOMER : RS Components

PRODUCT NAME: CERAMIC RESONATOR

PART NUMBER : 117-ZTT11.06MTF-W

Approved by	Checked by	Drawn by

Interquip Electronics Co., Ltd

Add : Flat A,9/F.,On Shing Industrial Building, 2 – 16 Wo Liu Hang Road,
Fotan, N.T., Hong Kong S.A.R.

Tel : 852- 2413 5515

Fax : 852-2413 7053

E-mail : iql@interquip.com

Part Number Sheet	
Customer	
Supplier P/N	117-ZTT11.06MTF-W
Customer P/N	

Customer's Approval Certificate	
Checked & Approved by	
Date	

Mark Of Modification	Reason Of Modification	Modification	Drawn	Checked	Approved	Date

Please return this copy after signing as a certification of your approval.

INTERQUIP ELECTRONICS CO., LTD.

1. SCOPE

This specification shall cover the characteristics of the ceramic resonator with the type 117-ZTT11.06MTF-W.

2. PART NO.

PART NUMBER
117- ZTT11.06MTF-W
CUSTOMER PART NO

3. OUTLINE DIMENSIONS AND MARK

3.1 Appearance: No visible damage and dirt.

3.2 Construction: Leads are soldered on electrode and body is molded by resin.

3.3 The products conform to the RoHS directive and national environment protection law.

3.4 Dimensions and mark

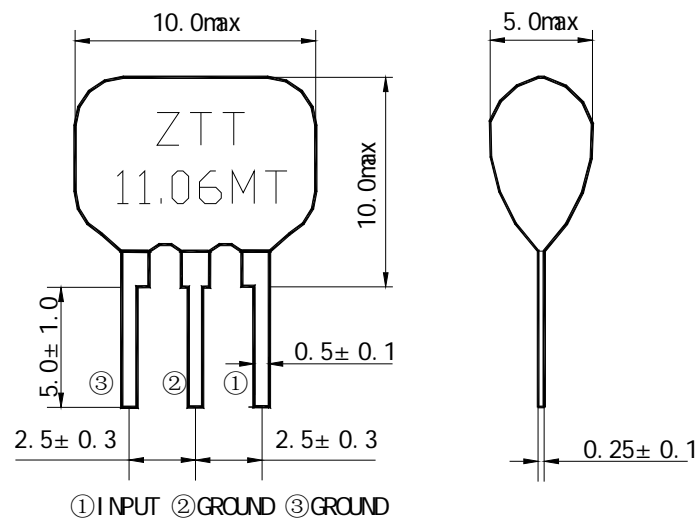

INTERQUIP ELECTRONICS CO., LTD.

4. ELECTRICAL SPECIFICATIONS

4.1 RATING

Items	Requirement
Withstanding Voltage (V)	50 (DC, 1min)
Insulation Resistance Ri, (MΩ) min.	500 (10V, 1min)
Operating temperature	-25°C ~ 85°C
Storage temperature	-55°C ~ +85°C
Rating Voltage UR (V)	6V DC
	15V p-p

4.2 ELECTRICAL SPECIFICATIONS

Items	Requirement
Oscillation Frequency Fosc (MHz)	11.060
Frequency Accuracy (%)	±0.5
Resonant Impedance Ro (Ω) max.	25
Temperature Coefficient of Oscillation Frequency (%) max.	±0.3 (Oscillation Frequency drift, -25°C ~ +85°C)
Oscillation Frequency Aging Rate (10years) (%) max *	±0.3 (From initial value)

* Components shall be left in a chamber of $+85 \pm 2^\circ\text{C}$ for 1000 hours, then measured after leaving in natural condition for 1 hour.

5. TEST

5.1 Test Conditions

Parts shall be tested under the condition (Temp.: $20 \pm 15^\circ\text{C}$, Humidity : $65 \pm 20\%$ R.H.) unless the standard condition (Temp.: $25 \pm 2^\circ\text{C}$, Humidity : $65 \pm 5\%$ R.H.) is regulated to measure.

5.2 Test Circuit

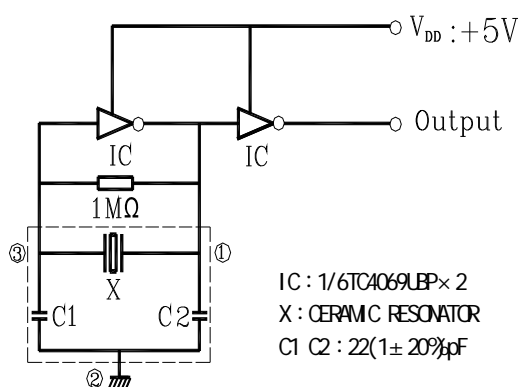

INTERQUIP ELECTRONICS CO., LTD.

6 PHYSICAL AND ENVIRONMENTAL CHARACTERISTICS

No.	Item	Condition of Test	Performance Requirement						
6.1	Humidity	Subject the resonator at $40 \pm 2^\circ\text{C}$ and 90%-95% R.H. for 500h, resonator shall be measured after being placed in natural conditions for 1h.	It shall fulfill Table 1.						
6.2	High Temperature Exposure	Subject the resonator to $85 \pm 2^\circ\text{C}$ for 500h, resonator shall be measured after being placed in natural conditions for 1h.	It shall fulfill Table 1.						
6.3	Low Temperature Exposure	Subject the resonator to $-55 \pm 2^\circ\text{C}$ for 500h, resonator shall be measured after being placed in natural conditions for 1h.	It shall fulfill Table 1.						
6.4	Temperature Cycling	<p>After temperature cycling of blow table was performed 5 times, resonator shall be measured after being placed in natural conditions for 1h.</p> <table border="1" style="width: 100%; margin-left: auto; margin-right: auto;"> <thead> <tr> <th style="text-align: center;">Temperature</th> <th style="text-align: center;">Time</th> </tr> </thead> <tbody> <tr> <td style="text-align: center;">$-25 \pm 3^\circ\text{C}$</td> <td style="text-align: center;">30 ± 3 min</td> </tr> <tr> <td style="text-align: center;">$85 \pm 3^\circ\text{C}$</td> <td style="text-align: center;">30 ± 3 min</td> </tr> </tbody> </table>	Temperature	Time	$-25 \pm 3^\circ\text{C}$	30 ± 3 min	$85 \pm 3^\circ\text{C}$	30 ± 3 min	It shall fulfill Table 1.
Temperature	Time								
$-25 \pm 3^\circ\text{C}$	30 ± 3 min								
$85 \pm 3^\circ\text{C}$	30 ± 3 min								
6.5	Vibration	Subject the resonator to vibration for 2h. Each in x y and z axis with the amplitude of 1.5mm, The frequency shall be varied uniformly between the limits of 10Hz-55Hz and then resonator shall be measured.	It shall fulfill Table 1.						
6.6	Mechanical Shock	Resonator shall be measured after 3 times random dropping from the height of 1m on concrete floor.	No visible damage and it shall fulfill Table 1.						
6.7	Resistance to Soldering Heat	Lead terminals are immersed up to 2 mm from resonator's body in soldering bath of $260^\circ\text{C} \pm 5^\circ\text{C}$ for $10\text{s} \pm 1\text{s}$ and then resonator shall be measured after being placed in natural conditions for 1h.	It shall fulfill Table 1.						
6.8	Solderability	Lead terminals are immersed up to 2mm from resonator's body in soldering bath of $250^\circ\text{C} \pm 5^\circ\text{C}$ for $3\text{s} \pm 0.5\text{s}$.	More than 95% of the terminal surface of the filter shall be covered with fresh solder.						

INTERQUIP ELECTRONICS CO., LTD.

6. ENVIRONMENTAL TEST

No.	Item	Condition of Test	Performance Requirements
6.9	Terminal Strength		
6.9.1	Terminal Pulling	Force of 5N is applied to each lead in axial direction for $10s \pm 1s$.	
6.9.2	Terminal Bending	When force of 5N is applied to each lead in axial direction, the lead shall be folded up 90° from the axial direction and folded back to the axial direction. The speed of folding shall be each 3s.	No visible damage and it shall fulfill Table 1.

Table 1

Item	Specification after test
Oscillation Frequency Change $\Delta f_{osc}/f_{osc}$ (%) max.	± 0.3
Resonant Impedance R_o (Ω) max.	25
The limits in the above table are referenced to the initial measurements.	

INTERQUIP ELECTRONICS CO., LTD.

7. PACKAGE

To protect the products in storage and transportation, it is necessary to pack them (outer and inner package). On paper pack, the following requirements are requested.

7.1 Dimensions and Mark

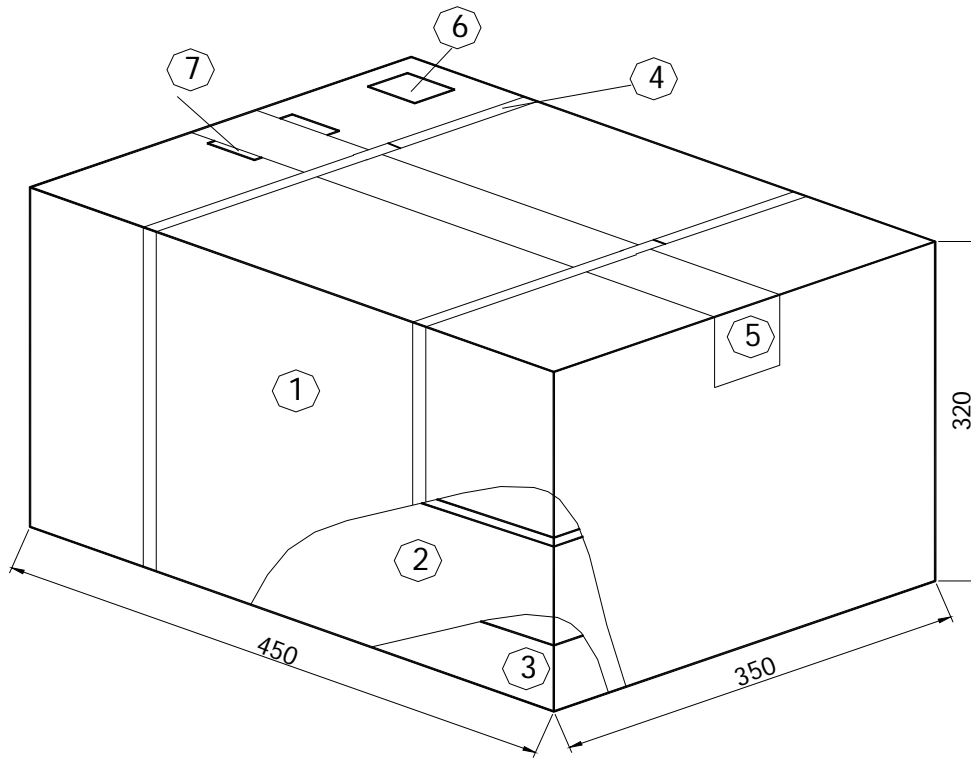

NO.	Name	Quantity
①	Package	1
②	Box	2
③	Inner Box	40
④	Belt	2.9 m
⑤	Adhesive tape	1.2 m
⑥	Label	1
⑦	Certificate of approval	1

7.2 Section of Package

Package is made of corrugated paper with thickness of 0.8cm. Package has 2 boxes, each has 20 inner boxes.

INTERQUIP ELECTRONICS CO., LTD.

7.3 Quantity of Package

Per plastic bag 500 pieces
 Per inner box 2 plastic bag
 Per package 40 inner boxes

(40000 pieces of piezoelectric ceramic part)

7.4 Inner Package

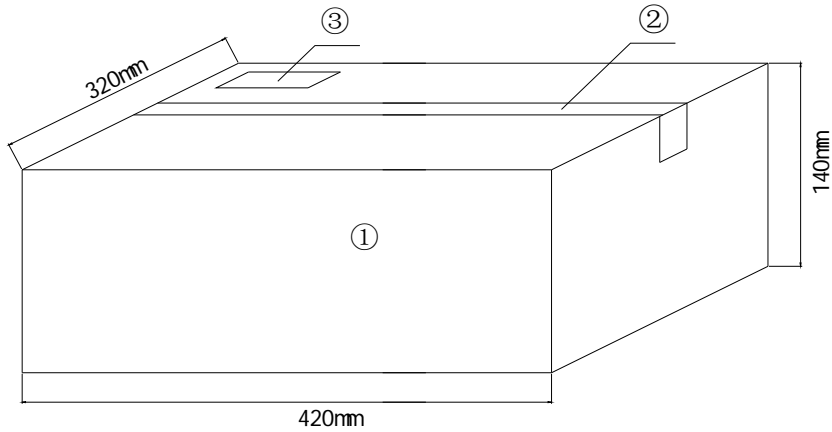

NO.	Name	Quantity
①	Inner package	1
②	Adhesive tape	1.2 m
③	Label	1

7.5 Inner Box Dimensions

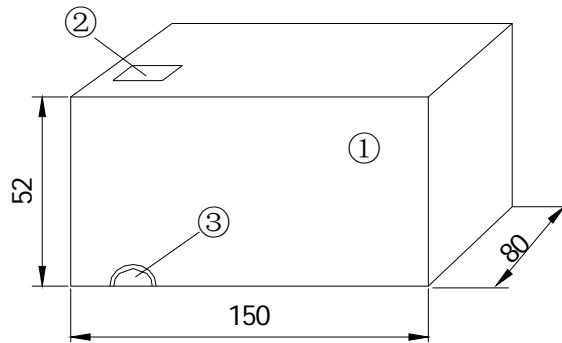

NO.	Name	Quantity
①	Inner Box	1
②	Label	1
③	QC Label	1

INTERQUIP ELECTRONICS CO., LTD.

8. OTHER

8.1 Caution

8.1.1 Don't apply excess mechanical stress to the component and terminals at soldering. Do not use this product with bend.

8.1.2 Do not clean or wash the component for it is not hermetically sealed.

8.1.3 Do not use strong acidity flux, more than 0.2wt% chlorine content, in flow soldering.

8.1.4 Don't be close to fire.

8.1.5 All kinds of re-flow soldering must not be applied on the component.

8.1.6 This specification mentions the quality of the component as a single unit. Please insure the component is thoroughly evaluated in your application circuit

8.1.7 Expire date (Shelf life) of the products is 12 months after delivery under the conditions of a sealed and an unopened package. Please use the products within 12 months after delivery. If you store the products for a long time (more than 12 months), use carefully because the products may be degraded in the solderability or rusty. Please confirm solderability and characteristics for the products regularly.

8.1.8 Please contact us before using the product as automobile electronic component.

8.2 Notice

8.2.1 Please return one of this specification after your signature of acceptance.

8.2.2 When something gets doubtful with this specifications, we shall jointly work to get an agreement.