

830 series

Silicon 25V hyperabrupt varactor diodes

ZC829, ZDC833, ZMV829, ZMDC830 and ZV831

Description

A range of silicon varactor diodes for use in frequency control and filtering. Featuring closely controlled CV characteristics and high Q. Low reverse current ensures very low phase noise performance. Available in single or dual common cathode format in a wide range of miniature surface mount packages.

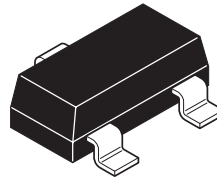

SOT23

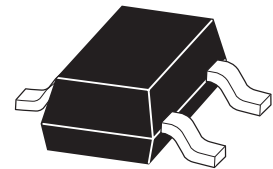

SOT323

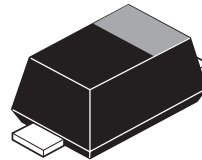

SOD523

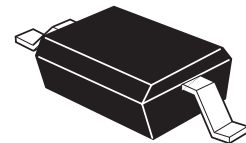

SOD323

Features

- Close tolerance CV characteristics
- High tuning ratio
- Low I_R (typically 200pA)
- Excellent phase noise performance
- High Q
- Range of miniature surface mount packages

Applications

- VCXO and TCXO
- Wireless communications
- Pagers
- Mobile radio

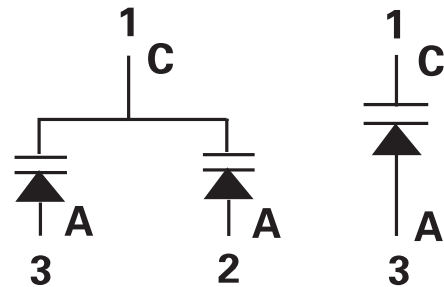

Where steeper CV slopes are required there is the 12V hyperabrupt range:

ZC930, ZMV930, ZV930 and ZV931

830 series

Order codes and device marking

SOD23		SOD323		SOD523		SOT23		SOT323	
Order code	Mark	Order code	Mark	Order code	Mark	Order code	Mark	Order code	Mark
ZC829ATA	J9A	ZMV829ATA	AA						
ZC829BTA	J9B	ZMV829BTA	CA						
ZC830ATA	J1A	ZMV830ATA	AB						
ZC830BTA	J1B	ZMV830BTA	CB						
ZC831ATA	J3A	ZMV831ATA	AC						
ZC831BTA	J3B	ZMV831BTA	CC	ZV831BV2TA	81			ZMDC831BTA	CC
ZC832ATA	J4A	ZMV832ATA	AD						
ZC832BTA	J4B	ZMV832BTA	CD	ZV832BV2TA	82			ZMDC832BTA	CD
ZC833ATA	J2A	ZMV833ATA	AE			ZDC833ATA	C2A		
ZC833BTA	J2B	ZMV833BTA	CE						
ZC834ATA	J5A	ZMV834ATA	AF			ZDC834ATA	C5A		
ZC834BTA	J5B	ZMV834BTA	CF						
ZC835ATA	J6A	ZMV835ATA	AG						
ZC835BTA	J6B	ZMV835BTA	CG						
ZC836ATA	J7A								
ZC836BTA	J7B								

Note:

The order codes are shown as TA which is for 7 inch reels. For 13 inch reels substitute TC in place of TA in the order code.

Tape and reel information

Reel code	Reel size (inches)	Tape width (millimeters)	Quantity per reel
TA	7	8	3,000
TC	13	8	10,000

830 series

Tuning characteristics at $T_{amb} = 25^{\circ}\text{C}$

Part	Capacitance (pF)			Min Q $V_R = 3V$ $f = 50\text{MHz}$	Capacitance ratio C_2 / C_{20} @ $f = 1\text{MHz}$	
	Min.	Nom.	Max.		Min.	Max.
829A	7.38	8.2	9.02	250	4.3	5.8
829B	7.79	8.2	8.61	250	4.3	5.8
830A	9.0	10.0	11.0	300	4.5	6.0
830B	9.5	10.0	10.5	300	4.5	6.0
831A	13.5	15.0	16.5	300	4.5	6.0
831B	14.25	15.0	15.75	300	4.5	6.0
832A	19.8	22.0	24.2	200	5.0	6.5
832B	20.9	22.0	23.1	200	5.0	6.5
833A	29.7	33.0	36.3	200	5.0	6.5
833B	31.35	33.0	34.65	200	5.0	6.5
834A	42.3	47.0	51.7	200	5.0	6.5
834B	44.65	47.0	49.35	200	5.0	6.5
835A	61.2	68.0	74.8	100	5.0	6.5
835B	64.6	68.0	71.4	100	5.0	6.5
836A	90.0	100.0	110.0	100	5.0	6.5
836B	95.0	100.0	105.0	100	5.0	6.5

Absolute maximum ratings

Parameter	Symbol	Max.	Unit
Forward current	I_F	200	mA
Power dissipation at $T_{amb} = 25^{\circ}\text{C}$ SOT23	P_{tot}	330	mW
Power dissipation at $T_{amb} = 25^{\circ}\text{C}$ SOD323	P_{tot}	330	mW
Power dissipation at $T_{amb} = 25^{\circ}\text{C}$ SOD523	P_{tot}	250	mW
Operating and storage temperature range		-55 to +150	$^{\circ}\text{C}$

Electrical characteristics at $T_{amb} = 25^{\circ}\text{C}$

Parameter	Conditions	Min.	Typ.	Max.	Unit
Reverse breakdown voltage	$I_R = 10\mu\text{A}$	25			V
Reverse voltage leakage	$V_R = 20V$		0.2	20	nA
Temperature coefficient of capacitance	$V_R = 3V, f = 1\text{MHz}$		300	400	ppCm/ $^{\circ}\text{C}$

830 series

Typical characteristics

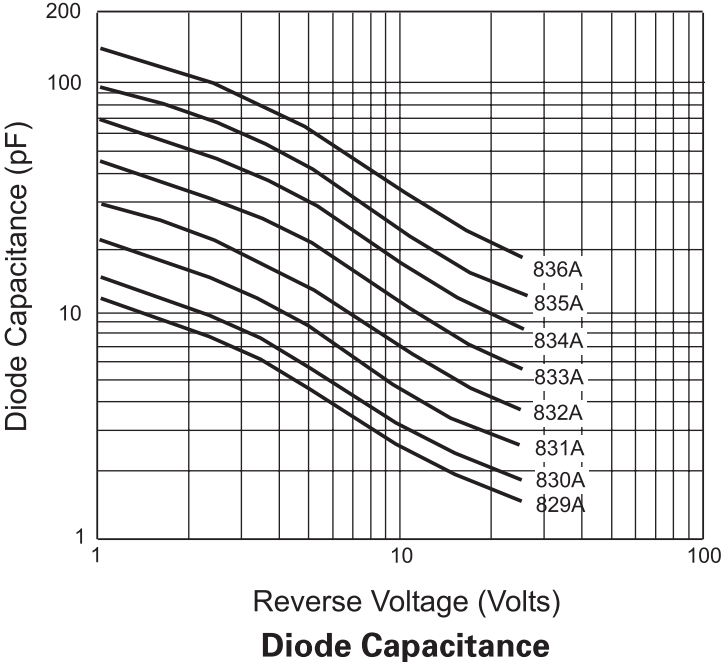

830 series

Package outline - SOT23

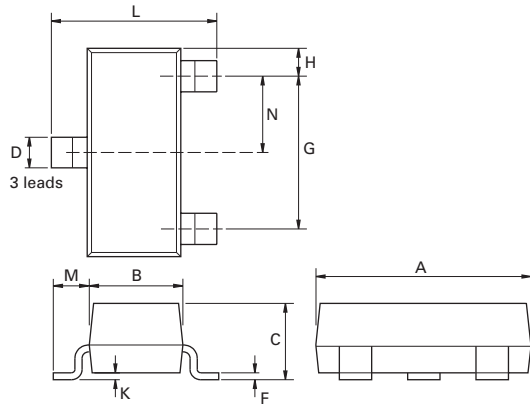

Dim.	Millimeters		Inches		Dim.	Millimeters		Inches	
	Min.	Max.	Min.	Max.		Min.	Max.	Max.	Max.
A	2.67	3.05	0.105	0.120	H	0.33	0.51	0.013	0.020
B	1.20	1.40	0.047	0.055	K	0.01	0.10	0.0004	0.004
C	-	1.10	-	0.043	L	2.10	2.50	0.083	0.0985
D	0.37	0.53	0.015	0.021	M	0.45	0.64	0.018	0.025
F	0.085	0.15	0.0034	0.0059	N	0.95 NOM		0.0375 NOM	
G	1.90 NOM		0.075 NOM		-	-	-	-	-

Note: Controlling dimensions are in millimeters. Approximate dimensions are provided in inches

Package outline - SOT323

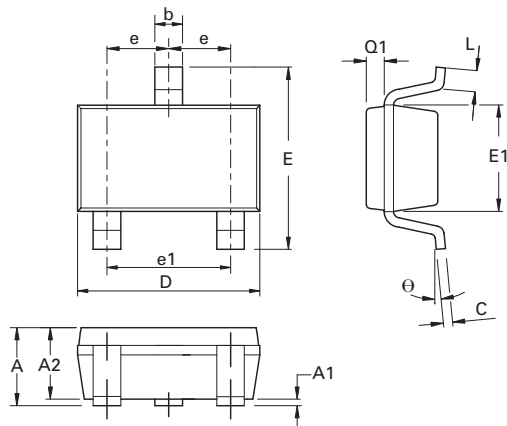

Dim.	Millimeters		Inches		Dim.	Millimeters		Inches	
	Min.	Max.	Min.	Max.		Min.	Max.	Max.	Max.
A	0.80	1.10	0.0315	0.0433	E1	1.15	1.35	0.0453	0.0532
A1	0	0.10	0	0.0039	e	0.65 BSC		0.0256 BSC	
A2	0.80	1.00	0.0315	0.394	e1	1.30 BSC		0.0512 BSC	
b	0.25	0.40	0.0098	0.0158	L	0.10	0.30	0.0039	0.0118
C	0.10	0.26	0.0039	0.0102	Q1	0.10	0.40	0.0039	0.0158
D	1.80	2.20	0.0709	0.0866	theta	0°	30°	0°	30°
E	1.80	2.40	0.0709	0.0945	-	-	-	-	-

Note: Controlling dimensions are in millimeters. Approximate dimensions are provided in inches

830 series

Package outline - SOD523

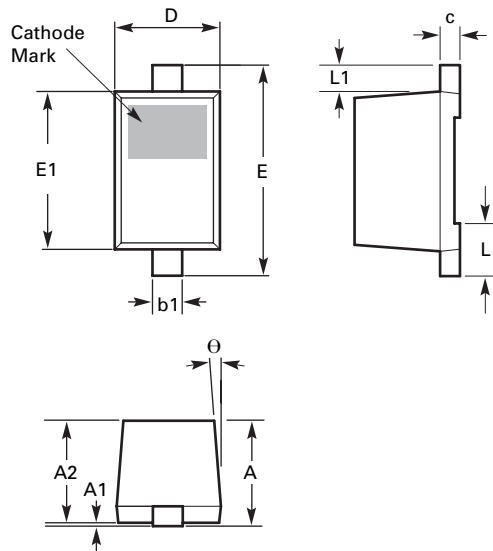

DIM	Millimeters		Inches		DIM	Millimeters		Inches	
	Min.	Max.	Min.	Max.		Min.	Max.	Min.	Max.
A	-	0.800	-	0.0314	E	1.500	1.700	0.0590	0.0669
A1	0.000	0.100	0.000	0.0039	E1	1.100	1.300	0.0433	0.0511
A2	0.600	0.800	0.0236	0.0314	L	0.200	0.400	0.0078	0.0157
b1	0.160	0.300	0.0062	0.0118	L1	0.170	0.230	0.0066	0.0090
c	0.080	0.220	0.0031	0.0086	U	4°	10°	4°	10°
D	0.700	0.900	0.0275	0.0354	-	-	-	-	-

Note: Controlling dimensions are in millimeters. Approximate dimensions are provided in inches

830 series

Package outline - SOD523

Top mark



Cathode terminal is to RIGHT HAND side of part mark
Part marking text displayed is for example only

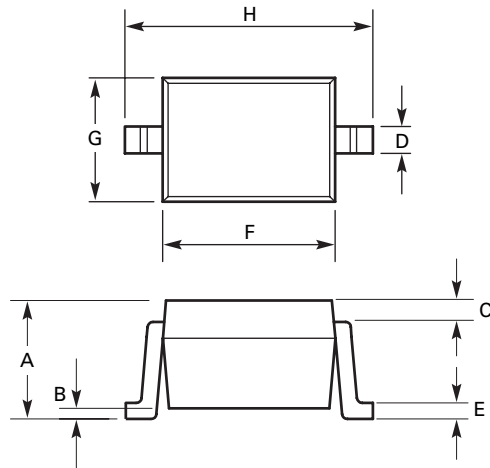

DIM	Millimeters		DIM	Millimeters	
	Min.	Max.		Min.	Max.
A	0.91	1.16	E	0.127	0.200
B	0.00	0.10	F	1.52	1.77
C	-	-	G	1.11	1.37
D	0.33	0.40	H	2.46	2.71

Europe

Zetex GmbH
Streitfeldstraße 19
D-81673 München
Germany

Telefon: (49) 89 45 49 49 0
Fax: (49) 89 45 49 49 49
europe.sales@zetex.com

Americas

Zetex Inc
700 Veterans Memorial Highway
Hauppauge, NY 11788
USA

Telephone: (1) 631 360 2222
Fax: (1) 631 360 8222
usa.sales@zetex.com

Asia Pacific

Zetex (Asia Ltd)
3701-04 Metroplaza Tower 1
Hing Fong Road, Kwai Fong
Hong Kong

Telephone: (852) 26100 611
Fax: (852) 24250 494
asia.sales@zetex.com

Corporate Headquarters

Zetex Semiconductors plc
Zetex Technology Park, Chadderton
Oldham, OL9 9LL
United Kingdom

Telephone: (44) 161 622 4444
Fax: (44) 161 622 4446
hq@zetex.com

For international sales offices visit www.zetex.com/offices

Zetex products are distributed worldwide. For details, see www.zetex.com/salesnetwork

This publication is issued to provide outline information only which (unless agreed by the company in writing) may not be used, applied or reproduced for any purpose or form part of any order or contact or be regarded as a representation relating to the products or services concerned. The company reserves the right to alter without notice the specification, design, price or conditions of supply of any product or service.