

# RE-max 13 $\varnothing$ 13 mm, Precious Metal Brushes CLL, 1.2 Watt

Kabel AWG 28/7  
cable UL Style 1061

⊕ Kabel rot  
cable red

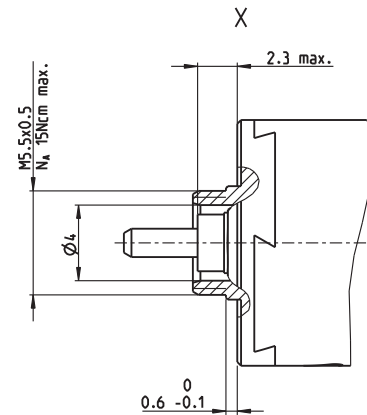
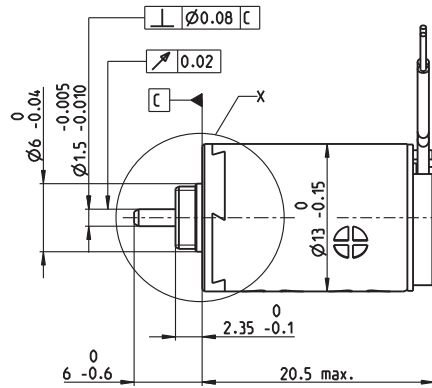
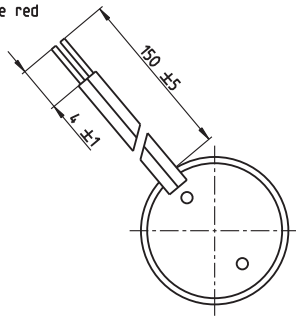

M 1.5:1

- Stock program
- Standard program
- Special program (on request)

## Part Numbers

201352 203881 203882 203883 203884 203885 203886 203887 203888 203889 203890 203891 203892 203893 203894

Motor Data		201352	203881	203882	203883	203884	203885	203886	203887	203888	203889	203890	203891	203892	203893	203894
<b>Values at nominal voltage</b>																
1 Nominal voltage	V	1	1.2	1.5	1.8	2.4	3	3.6	4.2	5	6	8	9	10	12	15
2 No load speed	rpm	11700	11400	11200	11100	11400	11700	12200	11600	11400	11100	11800	10700	11200	11300	10800
3 No load current	mA	68	55	42.8	35.1	27.5	22.7	20.3	16.1	13.2	10.4	8.69	6.65	6.36	5.43	4.02
4 Nominal speed	rpm	10200	9350	8720	7950	7350	6920	7070	6300	6020	5670	6440	5250	5630	5860	5240
5 Nominal torque (max. continuous torque)	mNm	0.334	0.422	0.552	0.682	0.898	1.11	1.28	1.31	1.29	1.3	1.28	1.27	1.26	1.27	1.26
6 Nominal current (max. continuous current)	A	0.48	0.48	0.48	0.48	0.48	0.48	0.48	0.4	0.325	0.263	0.209	0.167	0.155	0.132	0.0997
7 Stall torque	mNm	2.36	2.14	2.33	2.32	2.47	2.7	3.02	2.87	2.74	2.68	2.83	2.51	2.56	2.64	2.47
8 Starting current	A	2.94	2.18	1.87	1.53	1.26	1.12	1.09	0.846	0.668	0.527	0.447	0.321	0.306	0.267	0.19
9 Max. efficiency	%	73	72	73	73	73	74	75	75	75	75	75	74	74	74	74
<b>Characteristics</b>																
10 Terminal resistance	$\Omega$	0.34	0.55	0.802	1.17	1.91	2.67	3.29	4.96	7.48	11.4	17.9	28.1	32.7	44.9	78.9
11 Terminal inductance	mH	0.0056	0.0083	0.0135	0.0199	0.0333	0.0501	0.0661	0.0993	0.145	0.223	0.346	0.532	0.607	0.847	1.47
12 Torque constant	mNm/A	0.802	0.98	1.25	1.51	1.96	2.41	2.76	3.39	4.1	5.08	6.33	7.84	8.38	9.89	13
13 Speed constant	rpm/V	11900	9740	7650	6300	4870	3970	3460	2820	2330	1880	1510	1220	1140	965	734
14 Speed / torque gradient	rpm/mNm	5050	5470	4920	4880	4740	4400	4110	4130	4250	4210	4270	4360	4450	4380	4450
15 Mechanical time constant	ms	19	16.7	15.4	14.8	14.3	14	13.7	13.6	13.6	13.6	13.6	13.7	13.7	13.6	13.7
16 Rotor inertia	gcm <sup>2</sup>	0.358	0.291	0.299	0.29	0.288	0.303	0.318	0.315	0.306	0.308	0.304	0.3	0.293	0.297	0.294

## Specifications

Thermal data	
17 Thermal resistance housing-ambient	47.5 K/W
18 Thermal resistance winding-housing	14 K/W
19 Thermal time constant winding	5.11 s
20 Thermal time constant motor	186 s
21 Ambient temperature	-20...+65°C
22 Max. permissible winding temperature	+85°C

Mechanical data (sleeve bearings)	
23 Max. permissible speed	19000 rpm
24 Axial play	0.05 - 0.15 mm
25 Radial play	0.014 mm
26 Max. axial load (dynamic)	0.8 N
27 Max. force for press fits (static)	35 N
28 Max. radial load, 5 mm from flange	1.4 N

Other specifications	
29 Number of pole pairs	1
30 Number of commutator segments	7
31 Weight of motor	15 g
CLL = Capacitor Long Life Alignment of the electronic connections not specified	

Values listed in the table are nominal.  
Explanation of the figures on page 79.

## Operating Range

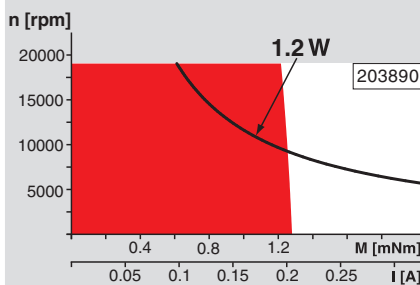

## Comments

**Continuous operation**  
In observation of above listed thermal resistance (lines 17 and 18) the maximum permissible winding temperature will be reached during continuous operation at 25°C ambient.  
= Thermal limit.

**Short term operation**  
The motor may be briefly overloaded (recurring).

— Assigned power rating

## maxon Modular System

Overview on page 20–25

### Planetary Gearhead

$\varnothing$ 13 mm  
0.05 - 0.15 Nm  
Page 247

### Planetary Gearhead

$\varnothing$ 13 mm  
0.2 - 0.35 Nm  
Page 248

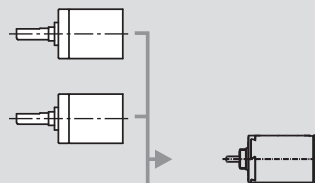

### Recommended Electronics:

ESCON 36/2 DC Page 342

ESCON Module 50/5 343

ESCON 50/5 344

Notes 22