

BExS120 / BExDS120 Alarm Sounders

The flameproof BExS120 alarm sounders are suitable for Zone 1 & Zone 2 applications and the BExDS120 sounders also for Zone 21 & 22.

Sound level outputs are up to 123dB(A) at 1 metre with a choice of 32 alarm tones and 3 remotely selectable stages. The BEx range features enclosures manufactured from corrosion proof, marine grade copper free LM6 aluminium which is phosphated and powder coated.

The re-entrant flare horns are high impact, fire retardant ABS. All models have two M20 cable entries, large termination areas containing in & out terminals (Ex de version only) and an ingress protection of IP66/67 (Ex d) and IP66 (Ex de).

For fire applications the BExS120D 24V dc siren is CPD EN89/106/EEC compliant (EN54-3 tested).

Approvals:

- ATEX certificate: KEMA 00ATEX6312, EN 60079-0 : 2006, EN 60079-1 : 2007, EN 60079-7 : 2003, EN 61241-0 : 2006, EN 61241-1 : 2004
- IECEx certificate: IECEx KEM 10.0003, IEC 60079-0 : 2004 (Ed4), IEC 60079-1 : 2007 (Ed6), IEC 60079-7 : 2001 (Ed3), IEC 61241-0 : 2004 (Ed1), IEC 61241-1 : 2004 (Ed1)
- GOST-R certificate: POCC GB.JB05.B02205
- VdS certificate: G206011
- CPD certificate: 0786-CPD-20225
- Safety-integrity suitability: SIL1
- Inmetro certificate: 10-Ex-0009

Features:

- Automatic synchronisation on multi-sounder system.
- Very large termination area.
- Ratchet adjustable stainless steel 'U' bracket.
- IN & OUT terminals (Ex de version only).
- 'Programmable' version available:
 - 45 alarm tones
 - 4 remotely selectable stages
 - Any tone can be assigned to any stage
 - User configurable continuous frequency tone



0786-CPD-20225

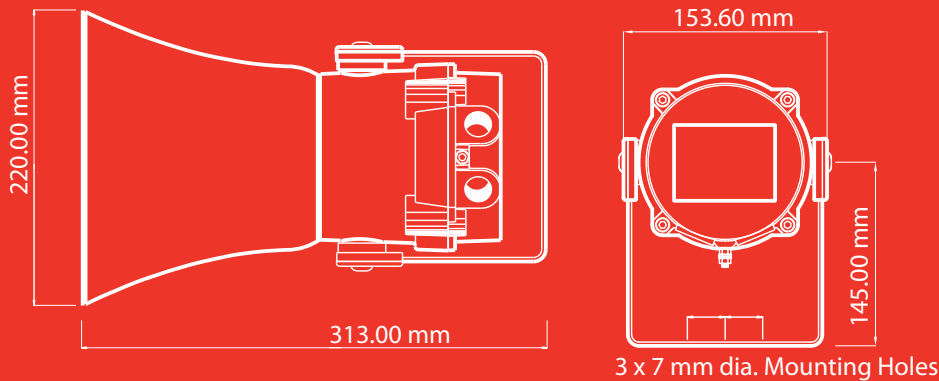

BExS120D & BExDS120D version

**Part codes:**

Part Code:	Classification:
BExS120D**	ATEX / IECEx: II 2G Ex d IIB T4 Ta. -50° to +70°C II 2G Ex d IIC T4 Ta. -50° to +55°C GOST-R: 1ExdIICT4 Ta. -50° to +55°C
BExS120E**	ATEX / IECEx: II 2G Ex de IIB T4 Ta. -50° to +70°C II 2G Ex de IIC T4 Ta. -50° to +55°C GOST-R: 2ExdellCT4 Ta. -50° to +55°C
BExDS120D**	ATEX / IECEx: II 2G Ex d IIB T4 Ta. -50° to +70°C II 2G Ex d IIC T4 Ta. -50° to +55°C II 2D Ex tD A21 IP67 T115 based on a max. Ta. of 70°C GOST-R: 1ExdIICT4 Ta. -50° to +55°C T100°C DIP A21 TaT4
BExDS120E**	ATEX / IECEx: II 2G Ex de IIB T4 Ta. -50° to +70°C II 2G Ex de IIC T4 Ta. -50° to +55°C II 2D Ex tD A21 IP66 T115 based on a max. Ta. of 70°C GOST-R: 2ExdellCT4 Ta. -50° to +55°C T100°C DIP A21 Ta T4

** = Voltage reference:

Options: 12DC, 24DC, 48DC, 115AC, 230AC

Add 'P' to part number for Programmable version

Specification:

Maximum output:	121dB(A) @ 1 metre
Nominal output:	117dB(A) @ 1m +/- 3dB - Tone 2
No. of tones:	32 (UKOOA / PFEER compliant)
No. of stages:	3
Volume control:	Max. 117dB(A); Min. 108dB(A) - Tone 2
Effective range:	200m @ 1KHz
Voltages DC:	12vdc; 24vdc; 48vdc
Voltages AC:	115vac; 230vac
Stage switching:	Negative or positive
Ingress protection:	S120D : IP66/67 S120E : IP66
Housing material:	Marine grade copper free LM6 Aluminium
Housing finish:	Phosphated & powder coated finish - anti-corrosion.
Colour:	RAL3000 Red (others available on request)
BExS120 flare:	High impact UL94 V0 & 5VA FR ABS (Red)
BExDS120 flare:	Anti-Static High impact ABS (Black)
Cable entries:	Dual M20 ISO (one stopping plug included)
Terminals:	0.5 to 4.0mm ² cables.
Line monitoring :	Min. 500 Ohm 2w, or 3k3 Ohm 0.5w res. or diode within Exd enclosure (dc versions).
Weight :	DC: 3.20kg AC: 3.40kg

*SPL data +/-3dB(A). Measured at optimum voltage.

BExS120E & BExDS120E version

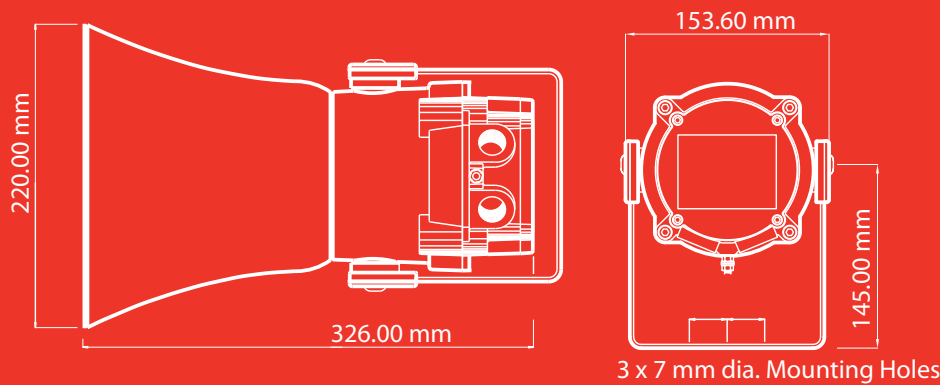

Stage 1	Frequency Description	dB @ 1m*	Stage 2	Stage 3
Tone 1	1000 Hz Continuous - PFEER Toxic Gas	117.0dB(A) @ 1m	Tone 31	Tone 11
Tone 2	800/1000Hz @ 0.25 sec Alternating	117.0dB(A) @ 1m	Tone 17	Tone 5
Tone 3	500/1200Hz @ 0.3Hz 0.5 sec Slow Whoop	118.0dB(A) @ 1m	Tone 2	Tone 5
Tone 4	800/1000Hz @ 1Hz Sweeping	117.5dB(A) @ 1m	Tone 6	Tone 5
Tone 5	2400Hz Continuous	114.5dB(A) @ 1m	Tone 3	Tone 27
Tone 6	2400/2900Hz @ 7Hz Sweeping	114.5dB(A) @ 1m	Tone 7	Tone 5
Tone 7	2400/2900Hz @ 1Hz Sweeping	111.5dB(A) @ 1m	Tone 10	Tone 5
Tone 8	500/1200/500Hz @ 0.3Hz Sweeping	118.0dB(A) @ 1m	Tone 2	Tone 5
Tone 9	1200/500Hz @ 1Hz - DIN / PFEER P.T.A.P.	118.0dB(A) @ 1m	Tone 15	Tone 2
Tone 10	2400/2900Hz @ 2Hz Alternating	113.5dB(A) @ 1m	Tone 7	Tone 5
Tone 11	1000Hz @ 0.5Hz Intermittent	118.0dB(A) @ 1m	Tone 31	Tone 1
Tone 12	800/1000Hz @ 0.875Hz Alternating	118.0dB(A) @ 1m	Tone 4	Tone 5
Tone 13	2400Hz @ 1Hz Intermittent	115.5dB(A) @ 1m	Tone 15	Tone 5
Tone 14	800Hz 0.25sec on, 1 sec off Intermittent	107.5dB(A) @ 1m	Tone 4	Tone 5
Tone 15	800Hz Continuous	107.5dB(A) @ 1m	Tone 2	Tone 5
Tone 16	660Hz 150mS on, 150mS off Intermittent	108.5dB(A) @ 1m	Tone 18	Tone 5
Tone 17	544Hz (100mS)/440Hz (400mS) - NF S 32-001	110.5dB(A) @ 1m	Tone 2	Tone 27
Tone 18	660Hz 1.8sec on, 1.8sec off Intermittent	108.5dB(A) @ 1m	Tone 2	Tone 5
Tone 19	1.4KHz-1.6KHz 1s, 1.6KHz-1.4KHz 0.5s -NFC48-265	121.0dB(A) @ 1m	Tone 2	Tone 5
Tone 20	660Hz Continuous	108.5dB(A) @ 1m	Tone 2	Tone 5
Tone 21	554Hz/440Hz @ 1Hz Alternating	109.5dB(A) @ 1m	Tone 2	Tone 5
Tone 22	544Hz @ 0.875 sec. Intermittent	109.5dB(A) @ 1m	Tone 2	Tone 5
Tone 23	800Hz @ 2Hz Intermittent	107.5dB(A) @ 1m	Tone 6	Tone 5
Tone 24	800/1000Hz @ 50Hz Sweeping	114.5dB(A) @ 1m	Tone 29	Tone 5
Tone 25	2400/2900Hz @ 50Hz Sweeping	114.5dB(A) @ 1m	Tone 29	Tone 5
Tone 26	Bell	117.5dB(A) @ 1m	Tone 2	Tone 1
Tone 27	554Hz Continuous	109.5dB(A) @ 1m	Tone 26	Tone 5
Tone 28	440Hz Continuous	109.5dB(A) @ 1m	Tone 2	Tone 5
Tone 29	800/1000Hz @ 7Hz Sweeping	113.0dB(A) @ 1m	Tone 7	Tone 5
Tone 30	AS2220: 420Hz repeating 0.625 sec on, 0.625 sec off.	109.5dB(A) @ 1m	Tone 32	Tone 5
Tone 31	660/1200Hz @ 1Hz Sweeping	118.0dB(A) @ 1m	Tone 11	Tone 1
Tone 32	AS2220: 500-1200Hz 3.75s on 0.25s off (15 cycles/min)	118.0dB(A) @ 1m	Tone 26	Tone 1

Current consumption:

Version:	Voltage range:	Current:
12V dc	+/-25%	850mA
24V dc	+/-25%	800mA
48V dc	+/-25%	420mA
115V ac	50/60Hz +10/-10%	180mA
230V ac	50/60Hz +10/-10%	90mA