

## TECHNICAL DATA SHEET

The LED-TL beacons have been designed to offer low maintenance, long life and a cost effective solution for car park management, factory traffic control, automated gate and door control systems.

The modules use a 36 SMT LED array that fits in the lens and offers a static light when energised. The **amber module only** can be reset to **flash mode** at the time of installation. One, two and three module bracket kits are available which allow for column or row mounting of modules.

Code No:	Voltage:	Light Source:	Current:
LED-TL-01	8-20v Ac/Dc ~	36 SMT LEDs	240mA @12v Dc
LED-TL-02	20-30v Ac/Dc ~	36 SMT LEDs	120mA @24v Dc
LED-TL-03	35-85v Ac/Dc ~	36 SMT LEDs	76mA @48v Dc
LED-TL-05	40-380v Dc --- 85-280v Ac ~	36 SMT LEDs	35mA @ 230v Ac

For Lens colours add: 01 Amber, 02 Red, 04 Green

### Key Features Include:

- Terminal block accepts up to 2.5mm<sup>2</sup> (14-22 AWG) stranded core with 4mm cut back
- Suitable for conduit box or wall mounting
- 120° prime light output above the vertical axis
- Ingress Protection: Weatherproof to IP65
- Flash Rate: 60 & 120 Flashes / minute (Nominal) (Amber module only)
- Operating Temperature Range: -25 + 55°C
- Enclosure Materials: UV Stable Polycarbonate Lens & Shroud  
UV Stable ABS Base
- AC Supply: 50/60 Hz

### General

- Installation must be carried out in accordance with the latest codes of practice and regulations by a qualified engineer.
- Ensure power source is disconnected prior to installation or maintenance to avoid danger of electrical shock.
- Do not handle internal electrical components whilst wiring up.
- Environmental exposure conditions during installation should be dry, moist or wet conditions should be avoided.
- The lens material of the beacon is VO rated UV stable polycarbonate plastic. Do not clean with petroleum based cleaners.
- Avoid mounting the beacon where it will be subject to excessive vibration.

Moflash part code S00602



## INSTALLATION & TECHNICAL INFORMATION

PLEASE READ PRIOR TO INSTALLATION



### LED-TL Modular Series - (LED Array)

#### Surface or Bracket Mounted

VISUAL SIGNALLING DEVICES

APPROVED AND  
CONFORMITIES



Website: [www.moflash.com](http://www.moflash.com)

Email: [technical@moflash.co.uk](mailto:technical@moflash.co.uk)

## INSTALLATION DATA SHEET

Each LED-TL module is supplied with an adaptor kit to allow the construction of multiple assemblies if required. The kit consists of: 1 x M20 adaptor, 2 x M20 washers, 2 x M20 locknuts and 2 x No 2 self-tapping screws.

Bracket kits are supplied with additional glands and washers to complete assemblies.

The **Amber module only** is supplied **pre-set to steady light** but can be reset to **flash mode**.

### Surface Mounted Modules (see diagram 1)

Remove the 2 screws retaining the shroud and lens, remove shroud and carefully pull lens from the back box. Remove the appropriate fixing hole and conduit knockouts as required for the installation. For multiple module assemblies - Remove additional side conduit knockouts to allow modules to be connected together. Place 1 x sealing washer each side of the M20 conduit adaptor and connect the bases together with the M20 locknuts. Do not over tighten the locknuts (see diagram 2). Mount the base(s) on a vertical surface or conduit box(es) using the gasket(s) supplied.

Insert the power cable into the base, via a suitable cable gland (not supplied), and connect to the terminal block mounted on the PCB fitted in the lens.

Connect the Live/Positive to the **Vin** terminal, Neutral/Negative to the **Øv** terminal.  
To set Amber module to **flash mode @ 120 flash/min**: **Fit link at J5** pin header.  
To set **flash mode @ 60 flash/min**: **Fit link at J5** and **remove link at J1** pin headers.

Ensure the 'O' ring(s) is in place on the base spigot(s).  
Line up the lens holes with those in the base and carefully snap the lens into position, taking care that the power cables do not foul PCB components. Fit the shroud over the lens and secure in position with the screws.

Diagram 1

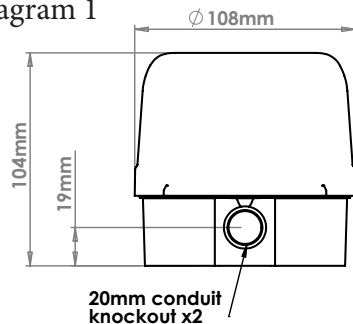
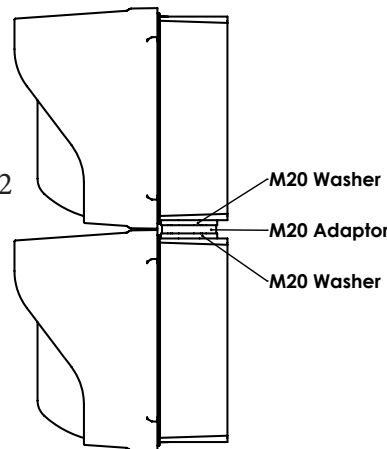

Diagram 2



### Bracket Mounted Modules (see diagrams 3 & 4)

No of Modules	Single	Double	Triple
Bracket Part No	50124	50125	50126
'L' (mm)	118	227	336

Position the bracket on the mounting surface, mark and drill appropriate holes for the fixing screws, not supplied. The brackets are designed with a key hole slot at the top and an elongated one at the bottom (see diagram 3).

Remove shroud and lens from the module, as for surface mount modules. Remove both side conduit knockouts from each module. Assemble the bases together using the adaptor kits supplied with the modules. (see diagram 2). Assemble the M20 glands and locknuts into the top and bottom module of the assembly discarding the supplied white washer from the gland and replacing it with the M20 x 1.2mm thick black one. (see diagram 4).

Insert the assembly into the bracket and lightly secure to the bracket with the M16 gland cap at the top and the M16 cable gland at the bottom (see diagram 4). This allows the assembly to be swivelled to fix the bracket in position and beacons to be pointed in the position of best visibility. Tighten the gland cap and gland to secure.

Insert the power cable into the cable gland (4.5 - 10mm cable diameter), and connect to the terminal blocks mounted in the lens of each module.

Connect Live/Positive to the **Vin**, Neutral/Negative to the **Øv** terminals.  
To set Amber module to **flash mode @ 120 flash/min**: **Fit link at J5** pin header.  
To set **flash mode @ 60 flash/min**: **Fit link at J5** and **remove link at J1** pin headers.

Ensure 'O' rings are in place on bases. Line up the lens holes with those in the base and carefully snap the lens into position, taking care that the power cables do not foul PCB components. Fit the shrouds over the lenses and secure in position with the screws.

Diagram 3

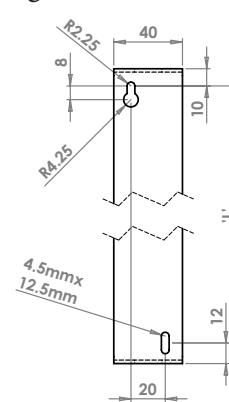

Diagram 4

