General safety advice for users

TSX 37 05/08/10/21/22 PLCs

Présentation	5
Physical description.....	8
Catalog summary	10
Dimensions (Dimensions in millimeters)	11
Installation rules	12
Mounting the PLC / mini-rack / modules	13
Connection of power supplies	16
Channel addressing	16

Discrete I/O

Connection equipment	19
General wiring rules and recommendations	21

Display bloc

Presentation	23
Display of PLC status	23
Display of I/O state	24
Display of 64 channel modules	24
Display of faults (DIAG mode)	25

Communication

Terminal port	27
---------------------	----

Analog/Counting

Analog	29
Counting	29
Characteristics	32

Connections

Ground connections	33
Power supplies	33

1 General

This documentation provides a legal framework for the use of Telemecanique Modicon Micro and Premium products, as well as associated documentation.

The content of the documentation is not contractually binding and can under no circumstances extend or restrict the scope of contractually binding warranty clauses.

2 Qualification of personnel

Only **qualified personnel** are authorized to install, operate or maintain the products. Any work performed by an unqualified person or non-observance of the safety instructions contained in this document or attached to the equipment may jeopardize the safety of personnel and/or cause irreparable damage to equipment.

3 Warnings

Warnings serve to prevent specific risks encountered by personnel and/or equipment. They are indicated in the documentations and on the products by different warning symbols.

Caution

Indicates that not following instructions or ignoring the warning may cause serious personal injury, death and/or serious damage to equipment.

Important or

Indicates that not following a specific instruction may lead to minor injury and/or damage to equipment.

Comment

Highlights important information relating to the product, its operation or its accompanying documentation.

4 Conformity of use

The products described in the documentations **conform to the European Directives** (*) to which they are subject (CE marking). However, they can only be used correctly in the context of the applications for which they are intended (described in the various documents) and when connected to approved third party products.

(*) EMC and LV Directives, concerning Electromagnetic Compatibility and Low Voltage.

5 Installing and setting up equipment

It is important to observe the following rules when installing and starting up equipment. In addition, if the installation includes digital links, it is essential to follow the basic wiring rules, given in the manual "Electromagnetic Compatibility of Industrial Networks and Fieldbuses", **reference TSX DG KBLE**.

- Safety instructions must be followed meticulously. These instructions are in the documentation or on the equipment being installed and set up.
- The type of equipment defines the way in which it should be installed :
 - A flush-mountable device (for example, a process control terminal) must be flush-mounted
 - A device which is to be built in (for example, a PLC) must be placed in a cabinet or enclosure
 - The casing of a laptop or portable device (for example, a programming terminal or a notebook) must remain closed

- If the device is permanently connected, its electrical installation must include a device to isolate it from the power supply and a circuit-breaker to protect it against overcurrents and isolation faults. If this is not the case, the power socket must be grounded and be easily accessed. **The device must be connected to the protective ground.**
- If the device is supplied with 24 or 48 VDC, the low voltage circuits must be protected. Only use power supplies which conform to the standards currently in force.
- Check that the supply voltages remain within the tolerance ranges defined in the technical characteristics of the devices.
- All measures must be taken to ensure that any power return (immediate, warm or cold) does not lead to a dangerous state which may place personnel or the installation at risk.
- Emergency stop devices must remain effective in all the device's operating modes, even those which are abnormal (for example, when a wire becomes disconnected). Resetting these devices must not cause uncontrolled or improper restarts.
- Cables which carry signals must be located where they do not cause interference with the control system functions by capacitive, inductive or electromagnetic interference.
- Control system equipment and their control devices must be installed in such a way as to ensure that they are protected against unintentional operation.
- Appropriate safety measures must be taken for the inputs and outputs, to prevent improper states in the control system device, if no signal is received.

6 Equipment operation

The operational safety and availability of a device is its ability to avoid the appearance of faults and to minimize their effects if they occur.

A fault inside the control system is known as :

- passive, if it results in an open output circuit (no command is sent to the actuators).
- active, if it results in a closed output circuit (a command is sent to the actuators).

From the safety point of view, a given fault is dangerous or not depending on the type of command given during normal operation. A passive fault is dangerous if the normal command is the operation of an alarm. An active fault is dangerous if it maintains or activates an undesirable command.

The system designer must **use devices external to the PLC** to protect against active faults inside the PLC, whether they are indicated or not.

7 Electrical and thermal characteristics

Details of the electrical and thermal characteristics of devices are given in the associated technical documents (installation manuals, service instructions).

8 Maintenance

Troubleshooting procedure

- Control system equipment should only be repaired by qualified personnel (after sales service engineer, or technician approved by Schneider Automation). Only certified replacement parts or components should be used.
- Before performing any operation on equipment, always disconnect the power supply and mechanically lock any moving parts.

Replacement and recycling of used batteries

Use batteries of the same type as the originals and dispose of defective batteries in the same way as toxic waste.

Présentation

• TSX 37 05 PLC

The TSX 37 05 PLC (1) integrates a 28 discrete I/O module as standard, (16I + 12Q) located in the first slot and has two half slots available.

Only one configuration is offered which has an AC supply and which does not manage remote I/O on a nano-PLC or AS-I bus link.

The available slot can be fitted with standard format modules (3) (discrete I/O) or two 1/2 format modules (4) (discrete I/O, emergency stop monitoring, analog, counting).

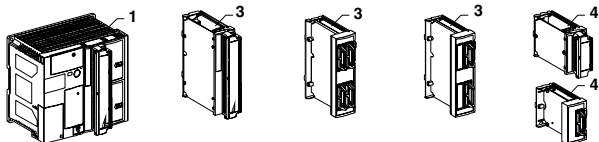

• TSX 37 08 PLC

The TSX 37 08 PLC (1) integrates two 28 discrete I/O modules as standard, (16I + 12Q) located in the first two slots and has two half slots available.

Only one configuration is offered which has an AC supply and which does not manage remote I/O on a nano-PLC or AS-I bus link.

The available slot can be fitted with standard format modules (3) (discrete I/O) or two 1/2 format modules (4) (discrete I/O, emergency stop monitoring, analog, counting).

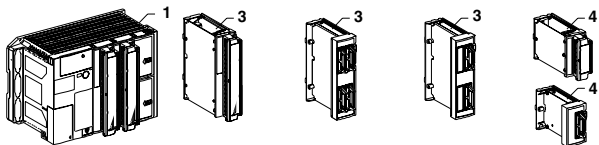

• TSX 37 10 PLCs

TSX 37 10 PLCs integrate a discrete I/O module as standard, located in the first slot and has two half slots available.

They offer six configurations differentiated by:

- the type of power supply, AC or DC,
- the I/O module integrated in the first slot.

Each base (1) integrates a real time clock (pv \geq 6) and can be extended using a mini extension rack (2).

The available slot can be equipped with standard format (3) (discrete I/O) or half-format modules (4) (discrete I/O, emergency stop monitoring, analog, counter, remote I/O).

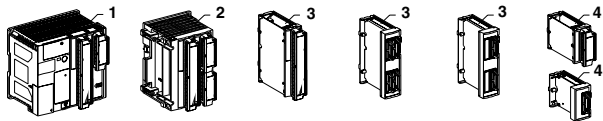

Moreover, each TSX 37 10 can manage remote I/O via remote modules :

- either on a nano-PLC link (discrete I/O from the TSX 07 nano-PLC (5) analog I/O from the TSX 07 range (6).

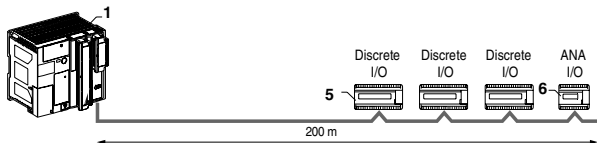

-or on an AS-i bus (sensor/actuator bus).

The maximum length of all the segments of the AS-i bus must not exceed 100 meters.

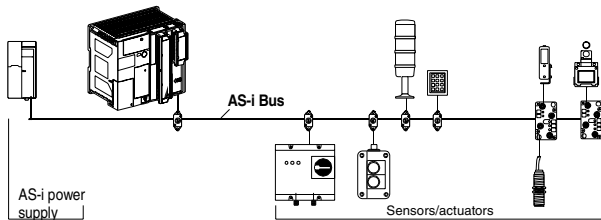

• TSX 37 21/22 PLCs

TSX 37-21/22 PLCs offer four configurations differentiated by their power supplies (alternating or direct current).

Each base (1) integrating a real-time clock, accepts a memory extension as well as a communication module and can be extended using a mini extension rack (2).

The 10 kHz counter functions and the analog I/O functions are integrated on TSX 37-22 PLCs. The positions available can be equipped with standard format (3) (discrete I/O) or half-format modules (4) (discrete I/O, emergency stop monitoring, analog, counter, remote I/O modules).

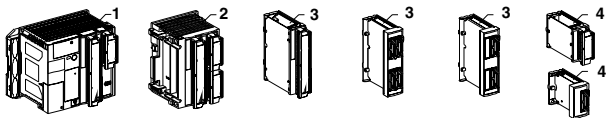

Moreover, each TSX 37 21/22 PLC can manage (via remote modules) remote I/O :

• either from nano-PLC links (discrete I/O from TSX 07 nano-PLCs) (5) and analog I/O from the TSX 07 range (6).

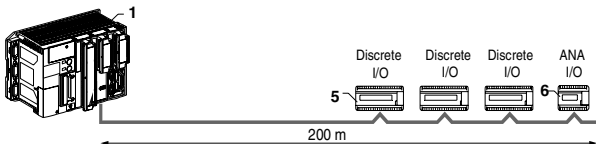

• or on an AS-i bus (sensor/actuator bus).

the maximum length of all the segments of the AS-i bus must not exceed 100 meters.

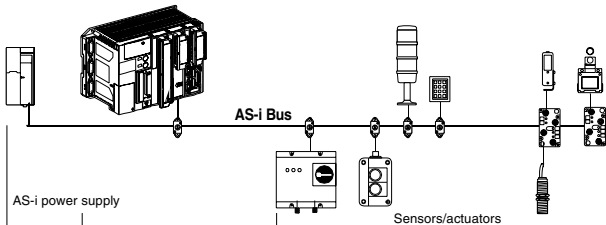

Physical description

• TSX 37 05 PLC

1 2-slot rack, integrating the power supply, the processor and its memory.

2 Centralized display block.

3 TER terminal port.

4 RESET button.

5 Cover for accessing power supply terminals.

6 Cover for accessing optional battery and operating system write-protection switch.

7 28 I/O module, located in the first slot.

Note : Optional battery : **TSX PLP 01**

• TSX 37 08 PLC

1 3-slot rack, integrating the power supply, the processor and its memory.

2 Centralized display block.

3 TER terminal port.

4 RESET button.

5 Cover for accessing power supply terminals.

6 Cover for accessing optional battery and operating system write-protection switch.

7 28 I/O modules, located in the first two slots.

Note : Optional battery : **TSX PLP 01**

• TSX 37 10 PLC

1 2-slot rack, integrating the power supply, the processor and its memory.

2 Centralized display block.

3 TER terminal port.

4 RESET button.

5 Cover for accessing power supply terminals.

6 Cover for accessing optional battery and operating system write-protection switch.

7 28 or 64 I/O module, by default located in the first slot.

8 Cover for mini extension rack connection.

Note : Optional battery : **TSX PLP 01**.

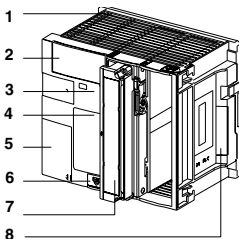
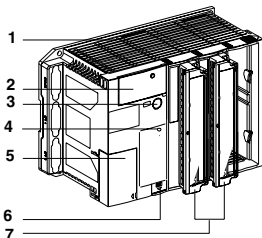
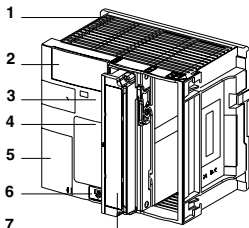

• TSX 37 21/22 PLCs

- 1 3-slot rack, integrating the power supply, the processor and its memory.
- 2 Centralized display block.
- 3 Integrated analog and counter functions (on TSX 37 22 PLC only).
- 4 TER terminal port and AUX man-machine interface port.
- 5 Cover for accessing power supply terminals.
- 6 Memory extension card slot. If no card is present, this slot is fitted with a cover which must be kept in place, as removing it will cause the PLC to stop.
- 7 Communication module slot.
- 8 Cover for accessing optional battery and operating system write-protection switch.
- 9 Cover for mini extension rack connection.

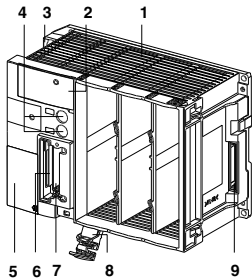

Note : PCMCIA format memory extension and communication module

Optional battery : **TSX PLP 01**

Important : Removing the handle causes the PLC to stop.

Mini extension rack TSX RKZ 02

- 1 2-slot extension rack.
- 2 Screw for fixing the extension to the base.
- 3 Indicator lamp showing presence of 24 V DC voltage.
- 4 Power supply terminals protected by a cover.
- 5 Ground terminal.
- 6 Connector to the PLC base.

Note : For an IP20 protection rating, TSX RKA 01 covers must be inserted over the empty positions.

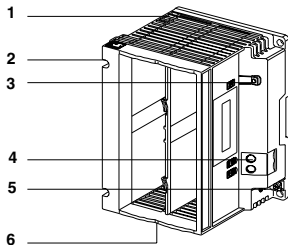

Catalog summary

• TSX 37 05/08/10 PLCs

Type of power supply		Integrated I/O modules					PLCs References TSX	
100... 240 V ~	24 V ≡	TSX Reference modules	Types of inputs		Types of outputs			
			24 V ≡	115 V ~	Trans. ≡ 24 V			Relay
					0.1 A	0.5 A		
•		DMZ 28 DR	•(1)				•	3705 028DR1
•		DMZ 28 DR	•(1)				•	3708 056DR1
•		DMZ 28 AR		•			•	3710 028AR1
•		DMZ 28 DR	•(1)				•	3710 028DR1
	•	DMZ 28 DR	•(1)				•	3710 128DR1
	•	DMZ 28 DT	•(2)			•		3710 128DT1
	•	DMZ 28 DTK (3)	•(2)			•		3710 128DTK1
	•	DMZ 64 DTK (3)	•(2)			•		3710 164DTK1

(1) Positive or negative logic inputs.

(2) Positive logic inputs.

(3) HE10 connector module.

• TSX 37 21/22 PLCs

Type of power supply		Integrated functions		PLC References TSX
100....240 V ~	24 V ≡	Counter	Analog	
•				TSX 37 21 001
	•			TSX 37 21 101
•		•	•	TSX 37 22 001
	•	•	•	TSX 37 22 101

• Mini extension rack

Désignation	Référence
Mini extension rack for TSX 37 10/21/22 PLCs	TSX RKZ 02

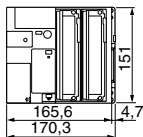
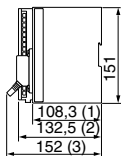
Dimensions (Dimensions in millimeters)

TSX 37 05
&
TSX 37 10

- (1) PLC only.
(2) Screw terminal block.
(3) HE10 or Sub D connector

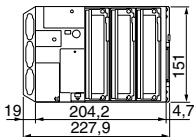

TSX 37 08 / 21 / 22

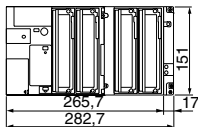

TSX 37 10
+
TSX RKZ 02

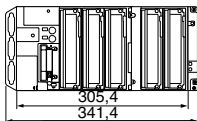

TSX 37 21 / 22
+
TSX RKZ 02

Installation rules (Dimensions in millimeters)**Horizontal mounting only**

- 1 Housing or enclosure.
- 2 Cable duct or clip.

Note :

If fan modules are used, see the quick reference guide supplied with these modules.

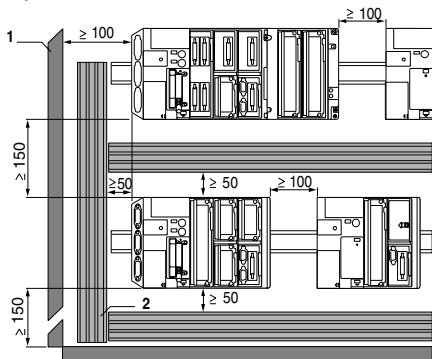

Mounting the PLC / mini-rack / modules

• Mounting on panel

- TSX 37 05 / 10 PLC

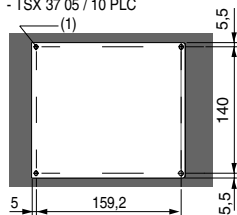

- TSX 37 10 PLC + TSX RKZ 02

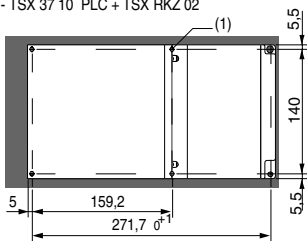

- TSX 37 08 / 21 / 22 PLC

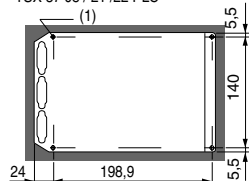

- TSX 37 21 / 22 PLCs + TSX RKZ 02

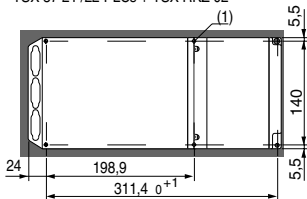

(1) The diameter of the mounting points must be sufficient to allow M4 screws to pass through

• Mounting on a Telequick mounting plate

Four Ø 4 screws with
M4x16 AF1-VA416
captive washers
and four M4 AF1 - EA4
clip nuts

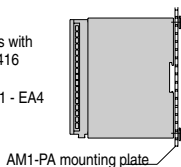

AM1-PA mounting plate

- **Mounting on a DIN rail**

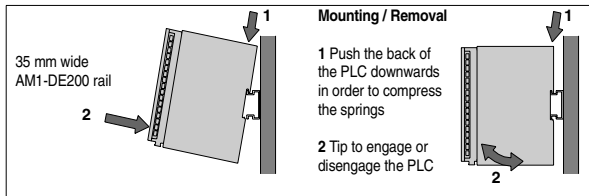

The PLCs must be mounted on metal supports which are correctly grounded.

- **Mounting the mini extension rack on a TSX 37 10/21/22 PLC base**

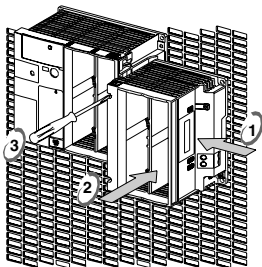

Remove the connector cover on the mini extension rack before carrying out procedures 1, 2 and 3.

Mounting / Removal to realize with power off

• Inserting a module

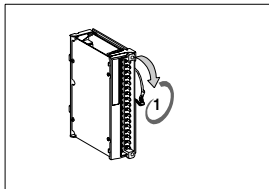

• Removing a module

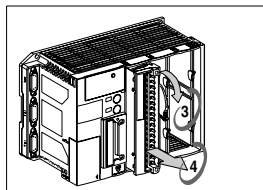
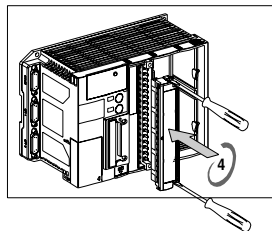
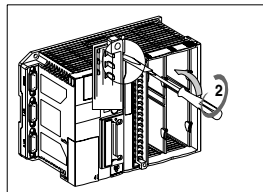
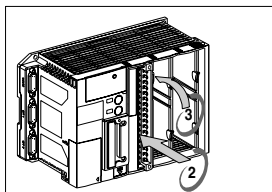
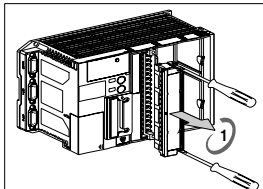

Terminal block module, sequences 1, 2, 3 and 4
HE10 connector module, sequences 1, 2 and 3.

Terminal block module, sequences 1, 2, 3 and 4
HE10 connector module, sequences 2, 3 and 4.

Note : procedure of insertion/removal identical for TSX 37 05/08/10, 37 21 et 37 22 PLCs.

Connection of power supplies

Connecting the PLC to the power supplies is covered in the connections section.

Note:

For TSX 37 10 PLCs, when the base is supplied with AC, the mini-rack must be supplied with 24 V DC if the following modules are located in the extension:

- Relay modules (tolerance of the external supply : 24 VDC \pm 10%).
- Analog modules.

Important : The 24 V sensor voltage provided by the base must not be used to supply the mini extension rack with 24 V DC (24 VR)

Channel addressing

Channel addressing is geographical, ie. it depends on the physical location of the module in the PLC or extension.

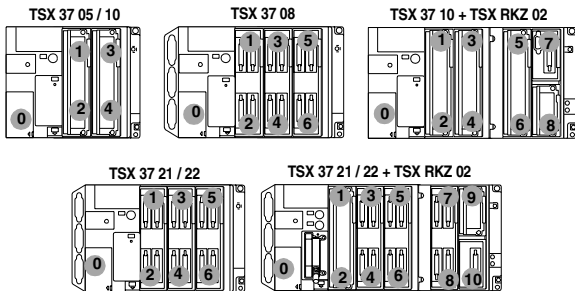

Since the standard modularity is half-format, standard format modules are addressed as two half-format modules, one above the other. In this section, the term position (of the module) represents either a half-format module, or the upper or lower part of a standard format module.

The syntax for a discrete I/O is as follows:

%	I or Q	Position	•	Voie
Symbol	I = Input Q = Output	X = 1 to 4 (37 05) X = 1 to 6 (37 08) X = 1 to 8 (37 10) X = 1 to 10 (37 21/22)	Dot	i

Channel addresses for each type of module :

Standard format module		64 I/O	32 I	32 O	28 I/O
Number of channel i	Odd position	0 to 31	0 to 15	0 to 15	0 to 15
	Even position	0 to 31	0 to 15	0 to 15	0 to 11
Channel address	Odd position	%Ix.0 to %Ix.31	%Ix.0 to %Ix.15	%Qx.0 to %Qx.15	%Ix.0 to %Ix.15
	Even position	%Q(x+1).0 to %Q(x+1).31	%I(x+1).0 to %I(x+1).15	%Q(x+1).0 to %Q(x+1).15	%Q(x+1).0 to %Q(x+1).11

Half-format module		16 I/O	12 I	8 O	4 O
Number of channel i	Even or oddposition	i : 0 to 7 Q : 8 to 15	0 to 11	0 to 7	0 to 3
Channel address	Even or oddposition	i : %Ix.0 to %Ix.7 Q : %Qx.8 to %Qx.15	%Ix.0 to %Ix.11	%Qx.0 to %Qx.7	%Qx.0 to %Qx.3

Connection equipment

• Connection to modules with screw terminal block

Each terminal may receive bare wires or wires equipped with cable ends, open or closed cable lugs :

- minimum : 1 wire, 0.28 mm², without cable end,
- maximum : 2 wires, 1 mm², with cable end or 1 wire, 1.5 mm², without cable end or, 1 open or closed cable lug for 1 mm²-wires

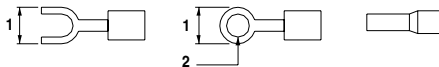

- 1 5,5 mm maximum,
2 Minimum diameter 3.2 mm

Maximum tightening torque on terminal block connection screw : 0.8 N.m

• Connection to modules with HE10 connectors

- Preformed connection cable with 20 flying leads, 22 gauge (0.324 mm²)

Allows wire-to-wire connection of I/O from modules with HE10 connectors to sensors, preactuators or terminals.

TSX CDP 301 : 3 meters long

TSXCDP 501 : 5 meters long

TSXCDP 1001 : 10 meters long

Terminal no.	Color of wire
1	White
2	Brown
3	Green
4	Yellow
5	Gray
6	Pink
7	Blue
8	Red
9	Black
10	Violet
11	Gray-Pink
12	Red-blue

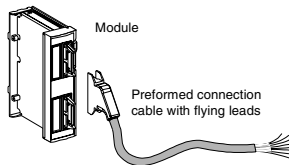

13	White-green
14	Brown-green
15	White-yellow
16	Yellow-brown
17	White-gray
18	Gray-brown
19	White-pink
20	Pink-brown

• **Rolled ribbon cable, 28 gauge (0,08 mm²)**

Used to connect I/O from modules with HE10 connectors to TELEFAST 2 connection interfaces. (current ≤ 100 mA/channel)

TSX CDP 102 : 1 meter long

TSX CDP 202 : 2 meters long

TSX CDP 302 : 3 meters long

• **Multi-core connection cable, 22 gauge (0,324 mm²)**

Used to connect I/O from modules with HE10 connectors to TELEFAST 2 connection interfaces. (current ≤ 500 mA/channel).

TSX CDP 053 : 0.5 meter long

TSX CDP 103 : 1 meter long

TSX CDP 203 : 2 meters long

TSX CDP 303 : 3 meters long

TSX CDP 503 : 5 meters long

• **Special case of the TSX DMZ 16 DTK module**

This module can be used to solve connection problems with applications using installation systems:

- Tego Dial : installation system for dialog components,
- Tego Power: installation system for motor starter units.

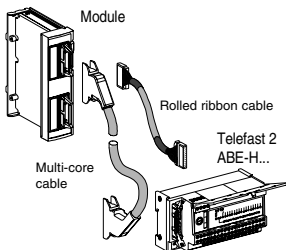

TSX DMZ 16 DTK

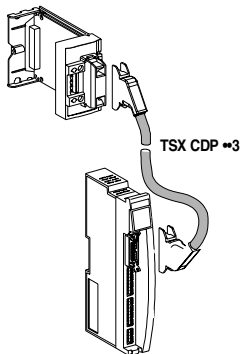

Communication module
APP-1CH

Tego Power

TSX DMZ 16 DTK

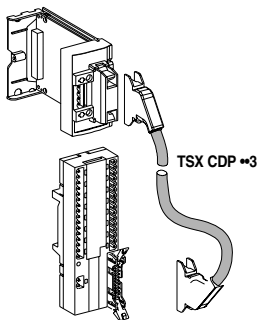

Dialbases Tego
APE-1B24M

Tego Dial

Maximum tightening torque on TSX CDP • cable connector screws: **0,5 N.m.**

General wiring rules and recommendations

External power supply for sensors and preactuators

These power supplies must be protected against short-circuits and overloads by fast blow fuses.

If the equipment does not conform to the Very Low Safety Voltage standard, the 24 V DC power supplies must have the 0 V connected to the mechanical ground, this being taken to ground as near to the power supply unit as possible. This is necessary for the safety of personnel in the event of one of the AC supply phases coming into contact with the 24 V DC.

Outputs:

- If the currents are high, it is advisable to segment the starts by protecting each one with a fast blow fuse.
- Use cables of sufficient cross section to avoid voltage drops and rises in temperature.

Cable routing

- Inside and outside the equipment.

In order to limit the A.C. coupling, the power circuit cables (power supply, power contactors, etc) must be separated from the input cables (sensors) and the output cables (preactuators).

- Outside the equipment.

All cables used for I/O must be placed in a sheath separated from that which holds the power cables. These cables must be separated by a minimum distance of 100 mm.

Presentation

The display block indicates the status of the PLC and its I/O. It provides access to channel and module diagnostics.

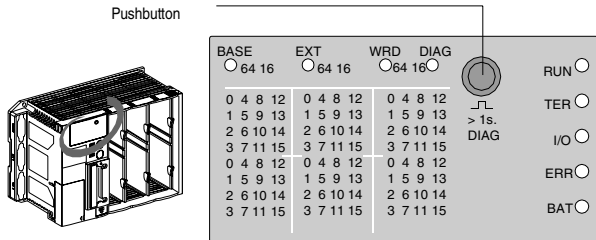

Display of PLC status

LED	State	PLC
RUN (Green)	On	PLC running (RUN)
	Flashing	PLC in STOP mode
	Off	No valid application in the PLC or PLC faulty
TER (Yellow)	On	Exchange of data via the terminal port
	Off	No exchange via the terminal port
I/O (Red)	On	I/O supply fault, tripping of a channel, module missing or switched off or not conforming to the configuration
	Off	Operation OK
ERR (Red)	On	CPU fault
	Flashing	No valid application in the PLC or "blocking fault" on the application program
	Off	Operation OK
BAT (1) (Red)	On	Battery faulty or missing
	Off	Battery OK

(1) The battery must be changed every two years. Update the label located in the hatch giving access to the power terminals.

Display of I/O state

The display block displays the I/O states of 2 or 3 modules simultaneously :

- 3 modules in the base (BASE LED on),
- or 2 modules in the mini extension rack (EXT LED on).

Briefly pressing the pushbutton selects the rack displayed (BASE or EXT).

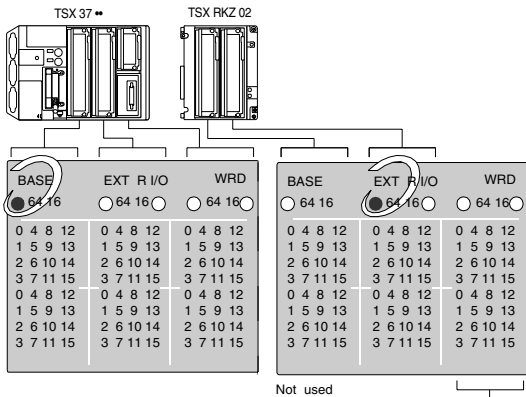

Display of 64 channel modules

When a 64 channel module is present in a slot, the corresponding LED 64 is on.

Briefly pressing the pushbutton displays either the first 16 inputs and the first 16 outputs (only LED 64 is on), or the next 16 inputs and next 16 outputs (LEDs 64 and 16 are on).

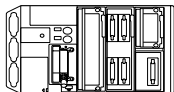

2nd PLC slot

64 I/O module

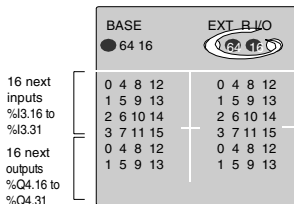
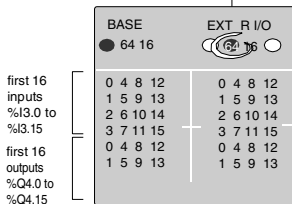

Display of faults (DIAG mode)

Diagnostics mode can be accessed by a long press of the pushbutton (> 1s). The DIAG LED is on.

- Input or output faulty (faulty supply, output tripped, etc) :

The corresponding LED flashes quickly.

- Module faulty (module missing, not conforming to the configuration, off, etc):

All the corresponding LEDs flash slowly(16 LEDs for a half-format module, 32 LEDs for a 28 I/O or 64 I/O module).

NOTE : Carry out a cold restart of the PLC to eliminate the I/O fault.

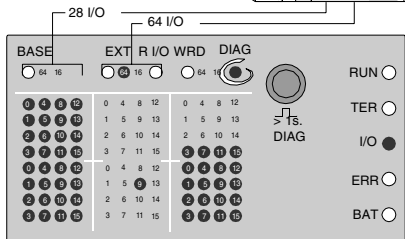
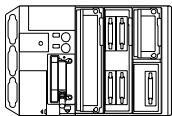

Terminal port

TSX 37-21/22 PLCs have two integrated terminal ports, TER and AUX. Although functionally identical, only the TER port enables a device without a power source to be connected.

The programming port allows 5 operating modes :

- UNI-TELWAY master (default configuration) or slave mode,
- Character string mode,
- Master/Slave Modbus/Jbus mode.

(Modbus / Jbus master on TSX 37-10/21/22 PLCs sv \geq 5.0).

Depending on the configuration mode selected during configuration, the following can be connected :

- A programming and adjustment terminal,
- An operator dialog device,
- Another PLC via a TSX P ACC01 block,
- A PLC to a Modbus/Jbus bus via a TSX P ACC01 block,
- UNI-TELWAY devices (sensors, preactuators, variable speed drives, etc),
- Slave Modbus devices (sensors, preactuators, variable speed drives, etc),
- A printer or monitor.

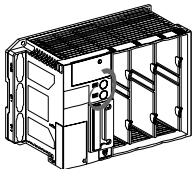

Analog

The information contained in this document only serves to remind the user of the various analog functions available with a TSX 37 05/08/10/21/22 PLC. To install the modules the following documents should be consulted :

- Quick reference guides for the module,
- TSX DM 37 **E manuals,
- TSX DS 37 PL7 **E manuals.

Counting

There are two (TSX 37 05/08/10/21) ou 3 (TSX 37 22) options for performing a downcounting, upcounting or up/down counting function

• On a discrete input

(max. frequency 500 Hz) :

- 2 counter channels provided by the first 4 inputs of the discrete I/O module, located in position 1.

• With a TSX CTZ 1A / 2A / 2AA module (max. frequency 40 kHz and 500 kHz)

- TSX CTZ 1A : 1 counter channel (40 kHz),
- TSX CTZ 2A : 2 counter channels (40 kHz),
- TSX CTZ 2AA : 2 counter channels (500 kHz).

• Integrated up/downcounting on TSX 37-22.

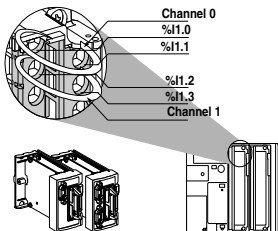

500 Hz up/down counting on discrete inputs

There are four possibilities for performing this function :

- 1 Use of a single physical up/down counter input, the direction (upcounting or downcounting) is defined by the software by setting a bit object to state 0 or 1. (1)
- 2 Use of a single up/down counter input, the direction (upcounting or downcounting) is defined by setting the second input to state 0 or 1. In this case, the software alone sets the preset value.

- 1 Channel 0 up/down counter
Channel 0 preset input
2 Channel 1 up/down counter input
Channel 1 counting direction
input (1)

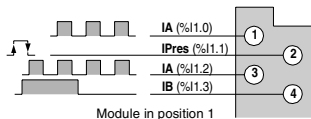

- (1) 0: Upcounting,
1: Downcounting

- 3 Use of two physical up/down counter inputs for each channel. In this case, the software alone sets the preset value.
- 4 Use of two up/down counter inputs with signals phase shifted by $\pi/2$ (incremental encoder signals) with hysteresis.
In this case, the software alone sets the preset value and the immunity of these four inputs is automatically set to the minimum value of 0.1 ms.

- 3 Channel 0 upcounter input
Channel 0 downcounter input
- 4 Channel 1 input A
Channel 1 input B

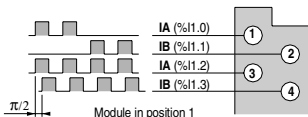

Integrated upcounting or downcounting on TSX 37-22

The upcounting or downcounting pulses are received on input IA.

Resetting to 0 (upcounting) or setting to a preset value (downcounting) can be performed in one of several ways :

- On a rising or falling edge of inputs IPres11 and IPres12 (respectively for channels 11 and 12),
- Automatically as soon as the setpoint value (upcounting) or 0 (downcounting) is reached, this choice having been made during configuration,
- By program.

IPres 11: Input reset to 0
or preset channel 11

IPres 12 : Input reset to 0
or preset channel 12

Notes :

- Channels 11 and 12 can be configured independently from each other,
- The input IPres 11 and the external supply for the encoder are connected on the CNT1 and CNT2 connectors in order to simplify wiring, particularly when using the encoder. In this case, CNT1 is reserved exclusively for connecting the encoder, CNT2 being used to connect input IPres 11 and the external supply for the encoder.

- (1) Power supply reserved exclusively for the encoder power supply.
- (2) External supply 10...30 VDC or 5 VDC for the encoder.

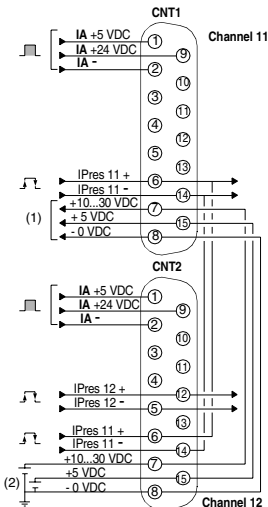

Integrated upcounting/downcounting on TSX 37-22

There are several configuration possibilities depending of the channel used :

Channels 11 and 12 :

- Use of a single physical up/down counter input, the direction (up/down counting) is defined by the application by setting a bit object to state 0 or 1.

Channel 11 only :

- Use of a single physical up/down counter input, the direction (up/down counting) is defined by the application by setting input IB to 0 or 1.
- Use of 2 physical inputs with upcounting on input IA and downcounting on output IB.
- Use of 2 physical inputs with signals phase shifted by $\pi/2$ (incremental encoder signals) without hysteresis and multiplication by 1 or 4 defined according to the configuration, input IA for A signals, input IB for B signals.

Setting to the preset value can be performed :

- On a rising or falling edge of IPres11 (channel 11), IPres12,
- On short cam reference point,
- By program.

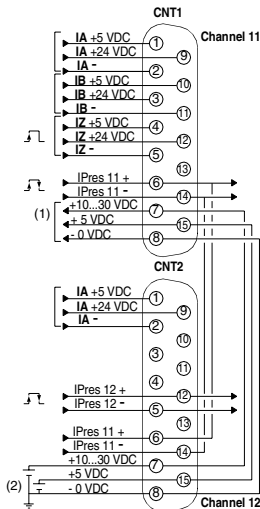

IZ : Zero marker input.

IPres11: Input reset to 0 or preset channel 11.

IPres12: Input reset to 0 or preset channel 12.

- (1) Power supply reserved exclusively to supply encoder.
- (2) 10...30 VDC or 5 VDC external supply for encoder.

Characteristics

PLCs power supply

Power supply type		AC	DC
Primary	Nominal voltages	100...240 VAC	24 VDC
	Voltage limits	90...264 VAC	19...30 VDC 19...34VDC (1)
	Nominal frequencies	50 ... 60 Hz	-
	Frequency limits	47 ... 63 Hz	-
	Current drawn	0,7 A ... 100 V 0,3 A ... 240 V	2 A
Secondary	+5VDC nominal current (2)	2,8 A	2,8 A
	+24V relay nominal current (2)	0,5 A	-
	+24V sensors nominal current (2)	0,4 A	-
	Nominal power	24 W	16 W
Isolation	Dielectric strength	2500 Veff 50 / 60 Hz	

(1) 34 VDC for one hour, for a battery device with charger.

(2) 2/3 of the I/O active simultaneously

Operating conditions

Operating temperature		0...+60°C (without ventilation unit)
Relative humidity		10...95% without condensation
Altitude		0...2000 m
Resistance to :	vibration	IEC 68-2-6, Fc test, 2g severity
	shock	IEC 68-2-27, Ea test
Resistance to :	electrostatic discharge	IEC 1000-4-2, level 3
	rapid transients	IEC 1000-4-4, level 3
Resistance to shock waves		IEC 1000-4-5
Storage temperature		- 25...+70°C
Mechanical safety		IP 20 with TSX RKA 01 covers in empty slots

Ground connections

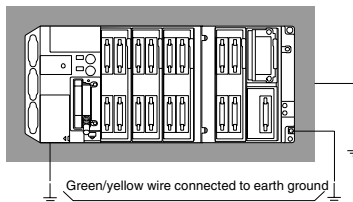

Support connected to earth ground

Important:

The PLC internal 0V is connected to the machine ground. The machine ground itself is connected to the earth ground.

Power supplies

• Connecting a TSX 37 05/08/10/21/22 PLC which is AC supplied (100 - 240 V)

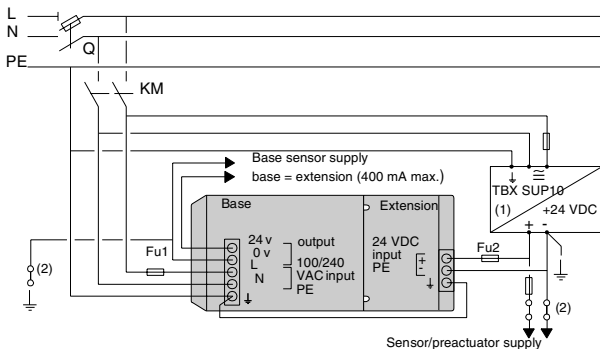

Q : general isolator

KM : line contactor or circuit-breaker,

Fu1 : 1A fuse, time-delayed

Fu2 : 0.5A standard

(1) power supply to be used only if discrete relay or analog modules are installed in the TSX RKZ 02 mini extension rack. If a TBX SUP 10 or TSX SUP 1011 power supply is used, remove FU2.

(2) isolation strip for locating ground fault. The external shunt must be removed in order to disconnect the supply terminal block from the PLC ground.

• **Connecting a TSX 37 10/21/22 PLC which is DC supplied**

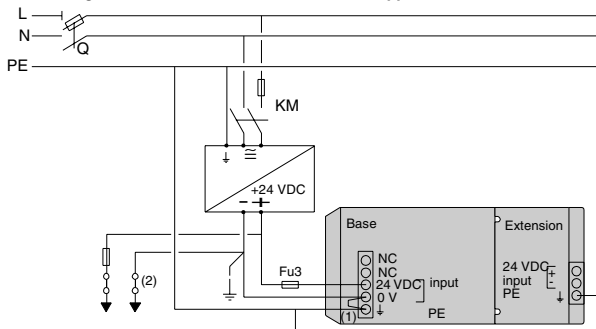

Sensor/preactuator supply

Q : general isolator

KM : line contactor or circuit-breaker

Fu3 : 4A fuse, time-delayed

(1) : external shunt supplied on the PLC. Must not be removed.

(2) : isolation strip for locating ground fault. The external shunt must be removed in order to disconnect the supply terminal block from the PLC ground.

• **Connecting a PLC (PLCs) which is (are) DC supplied from a floating DC supply network** (not connected to ground).

TSX 37 PLCs with 24 VDC supply network do not have primary/secondary isolation and the internal 0V is connected to the machine ground of the PLC. The 0V of the 24 VDC supply is thus connected to this same machine ground and particular methods of connection must be used for specific applications and especially Marine Applications using a free-floating mounting.

To connect a TSX 37 PLC to this type of "floating" network, it is necessary to place an isolated DC converter (24VDC/24VDC) next to each PLC, and upstream of the converter(s) use an isolation monitor.

- Connecting a TSX 37 10/21/22 PLC which is DC supplied from a floating DC supply network (not connected to ground).

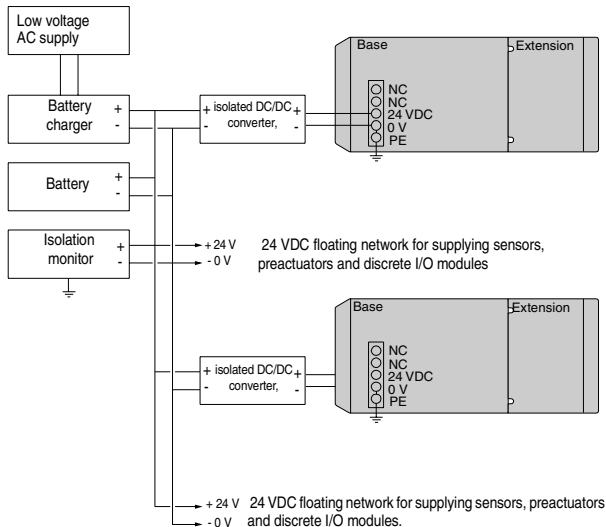

Note : the DC/DC converter must be as close as possible to the PLC and the + 24VDC polarity wire must be connected in such a way that it cannot be grounded accidentally.

Restrictions with this type of assembly:

- As analog I/O integrated in TSX 37 22 PLC bases are not isolated, they must not be used with this type of assembly. If the application requires analog I/O, use TSX AEZ●●●/ASZ●●● analog I/O modules.
- If modules with relay outputs are integrated in the PLC, the DC/DC converter must supply a voltage of 24 VDC \pm 10%.

Discrete I/O module connections

TSX DMZ 64 DTK

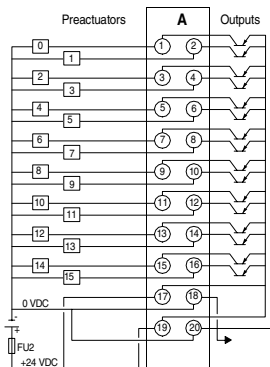
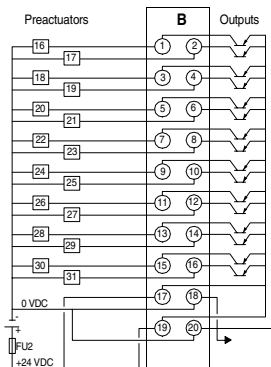
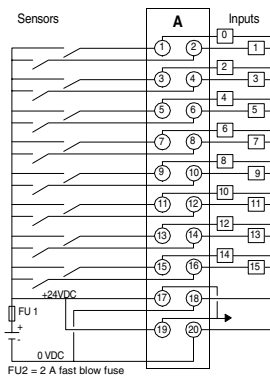
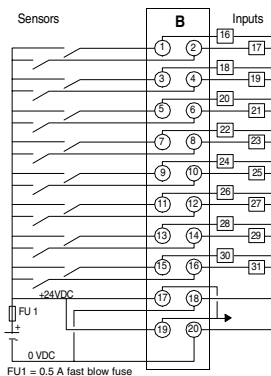

TSX DEZ 32D2

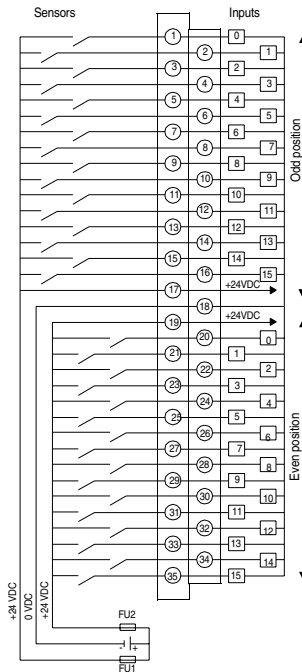

FU1 and FU2 = 0.5 A fast blow fuse

TSX DSZ 32T2

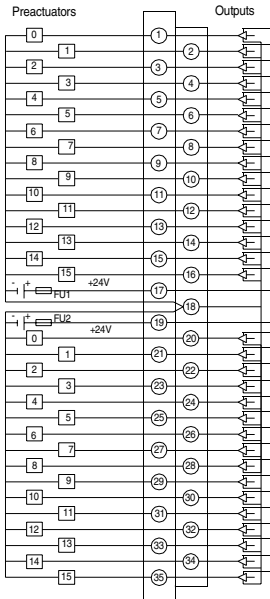

FU1 and FU2 = 10 A fast blow fuse

TSX DSZ 32R5

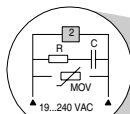

Load on AC
voltage

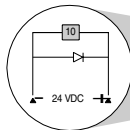

Load on DC
voltage

Protection must be provided
at the preactuator terminals.

FU1, FU2 and FU3 :
Fast blow fuses rated according to the load.

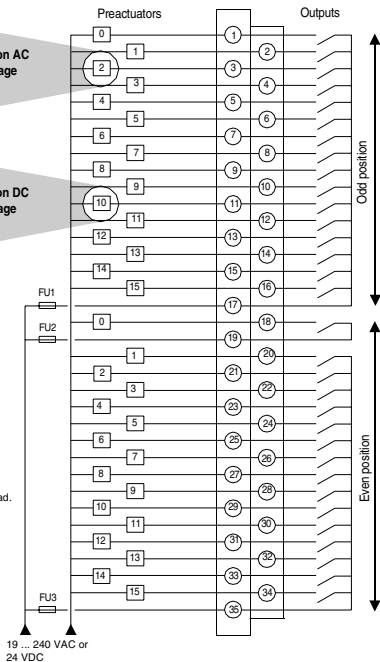

TSX DMZ 28DT

TSX DMZ 28DTK

Sensors

Inputs

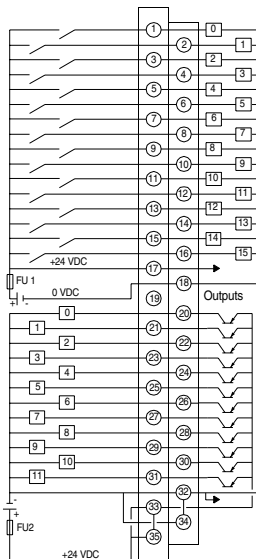

Preactuators

FU1= 0.5 A fast blow fuse

FU2= 6.3 A fast blow fuse

Sensors

Inputs

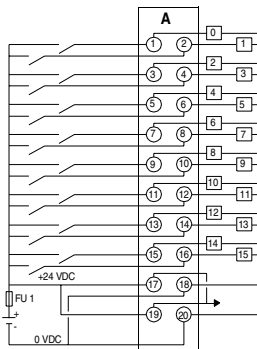

Preactuators

Outputs

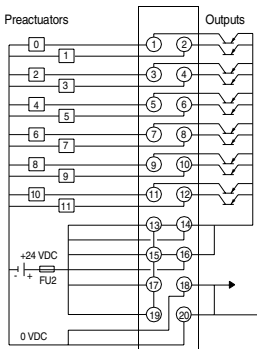

TSX DMZ 28AR (Positive logic inputs)

TSX DMZ 28DR (Negative logic inputs)

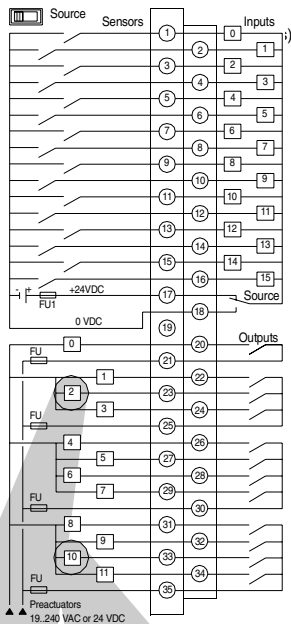
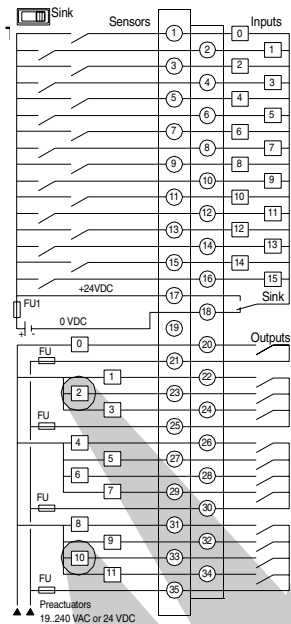

FU1 =
0.5 A fast-
blow fuse

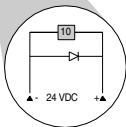
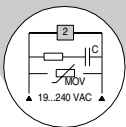
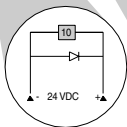

FU =
fast-blow fuse
rated according
to the load

Protection must be provided at the preactuator terminals

TSX DMZ 28 AR

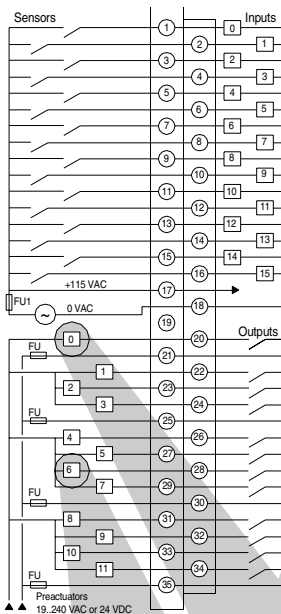

FU1 = 0.5 A fast blow fuse

FU = fast blow fuse rated according to the load

TSX DSZ 08R5

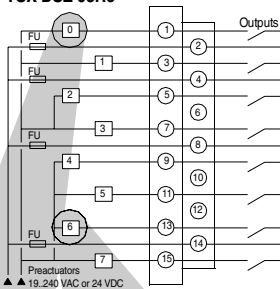

COMMONS

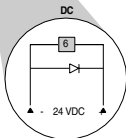
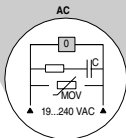
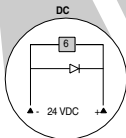

Protection must be provided at the preactuator terminals

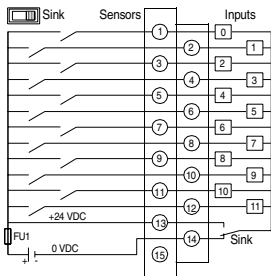
TSX DEZ 12D2 (Positive logic inputs) TSX DEZ 12D2 (Negative logic inputs)

FU1 = 0.5 A fast blow fuse

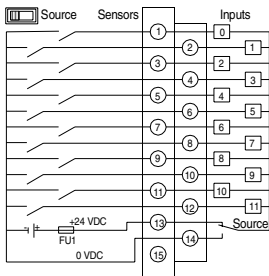

FU1 = 0.5 A fast blow fuse

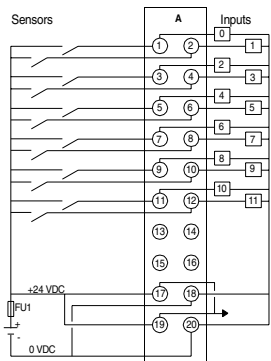
TSX DSZ 12D2K

FU1 = 0.5 A fast blow fuse

TSX DEZ 08A4

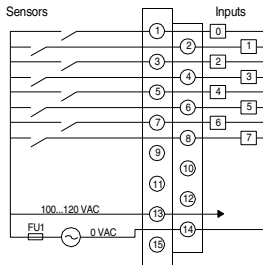

FU1 = 0.5 A fast blow fuse

TSX DEZ 08A5

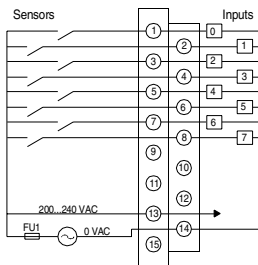

FU1 = 0.5 A fast blow fuse

TSX DSZ 08T2

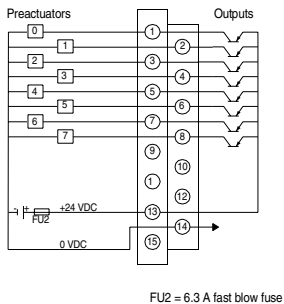

TSX DSZ 8T2K

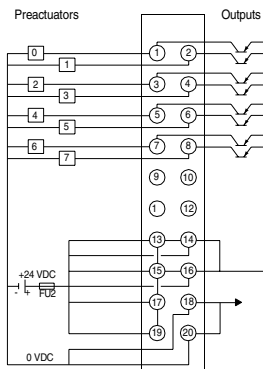

TSX DSZ 04T22

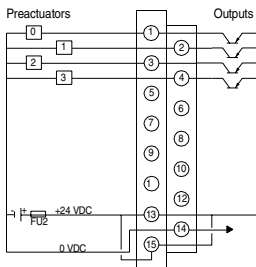

FU2 = 10 A fast blow fuse

- Principle for connecting the various internal components of the module

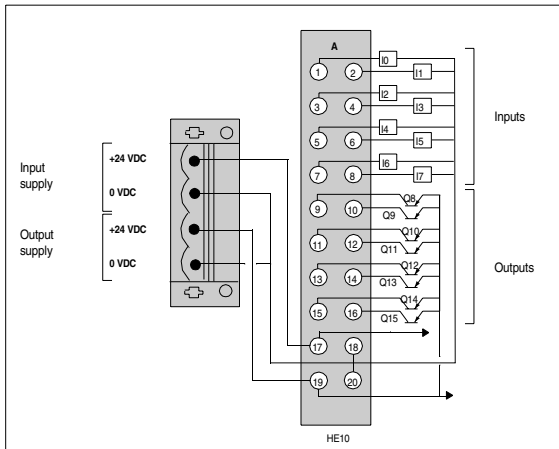

TSX DMZ 16DTK (continued)

- Connecting the TSX DMZ 16DTK module on a Dialbase sub-base (Tego Dial)

- First possibility

Connecting the sensor supply from the Tego Dialbase sub-base,

Connecting the preactuator supply from the enclosed terminal block. In all cases, the preactuator supply should be connected from an enclosed terminal block.

Connection principle diagram

Connection on an APE-1B24M Tego Dialbase sub-base

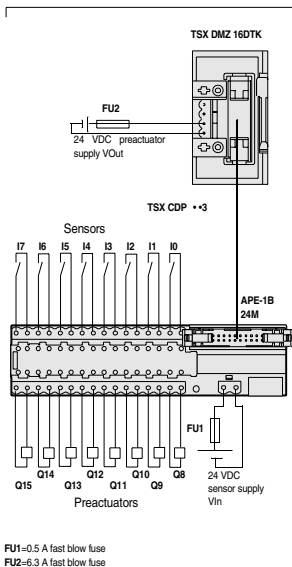
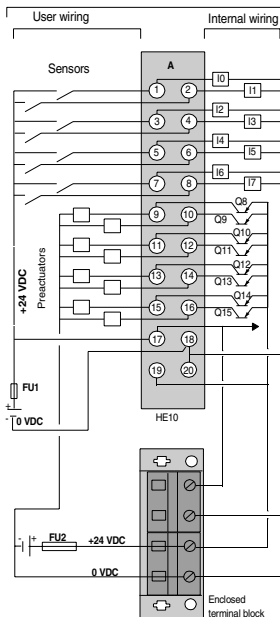

• **Connecting the TSX DMZ 16DTK module on a Dialbase sub-base (Tego Dial)** (continued)

-second possibility

Connecting sensors and preactuator supplies from the enclosed terminal block of the TSX DMZ 16DTK module

Connection diagram

Connection on an APE-1B24M Tego Dialbase sub-base

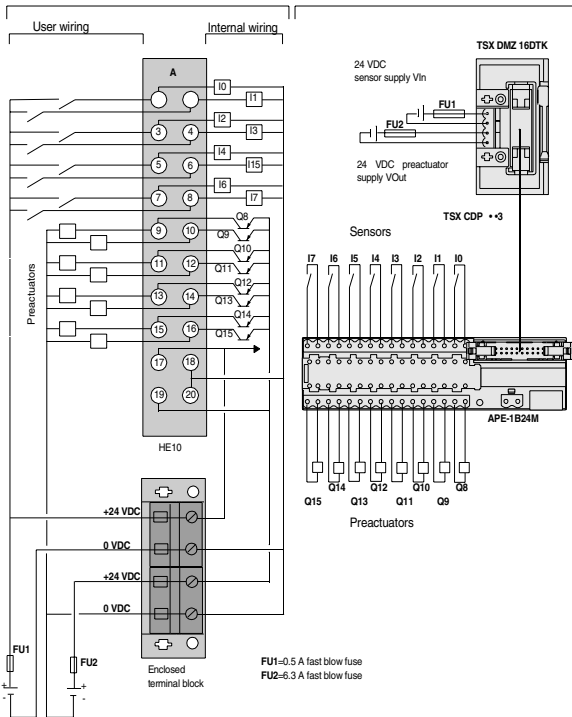

• Connecting the TSX DMZ 16DTK module on a communication module (Tego Power)

-First possibility

Connect the sensor and preactuator supplies from a APP-1CH communication module. In this case, the consumption by all the preactuators must be less than 0.7 A.

Connection principle diagram

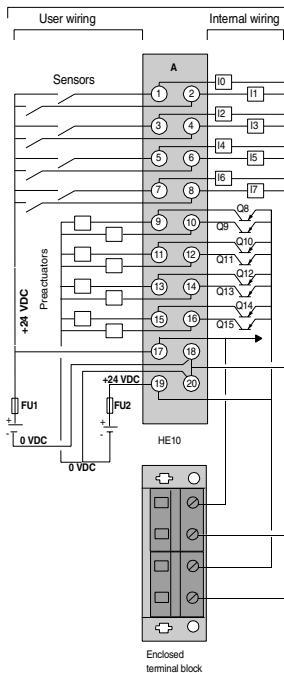

Connection on an APP-1CH Tego Power communication module

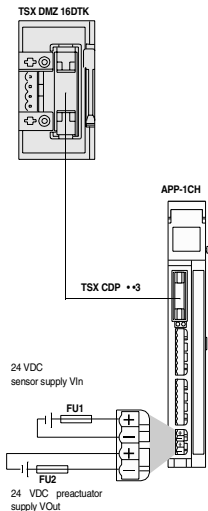

FU1=0.5 A fast blow fuse
FU2=6.3 A fast blow fuse

• Connecting the TSX DMZ 16DTK module on a communication module (Tego Power)

(continued)

-Second possibility

Connecting the sensor and preactuator supplies from the enclosed terminal block of the TSX DMZ 16DTK module. This connection method can be used if the power consumption of all preactuators is greater than 0.7 A.

Connection principle diagram

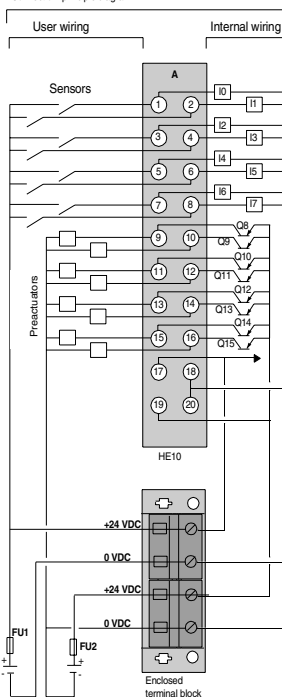

Connection on an APP-1CH Tego Power communication module

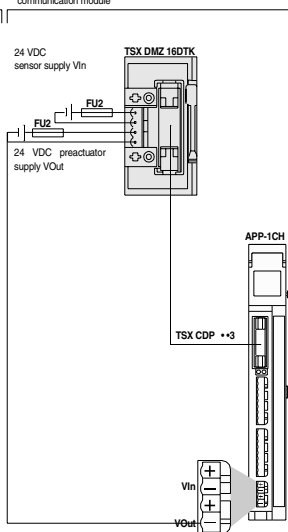

FU1=0.5 A fast blow fuse
FU2=6.3 A fast blow fuse