

Maintenance Parts List

Replaceable parts for devices are listed in series.

You can also refer to the replacement procedures for consumable parts of each series.

Actuators



Modular F.R.L. Pressure Control Equipment



Air Preparation Equipment Industrial Filters



CONTENTS

Maintenance Parts List

Actuators P.1

- 1 Cylinder inspection items
- 2 Troubleshooting
- 3 Details of replacement parts



Modular F.R.L. Pressure Control Equipment P.215

- 1 Indication of replacement of elements,
inspection items
- 2 Troubleshooting
- 3 Details of replacement parts



Air Preparation Equipment P.241

- 1 Indication of replacement of elements,
inspection items
- 2 Troubleshooting
- 3 Details of replacement parts



Industrial Filters P.241

- 1 Indication of replacement of elements,
inspection items
- 2 How to arrange replacement element
kit number selection
- 3 Details of replacement parts



Replacement Procedure

Actuators P.277

Modular F.R.L. Pressure Control Equipment P.397

Industrial Filters P.459

Actuators 1

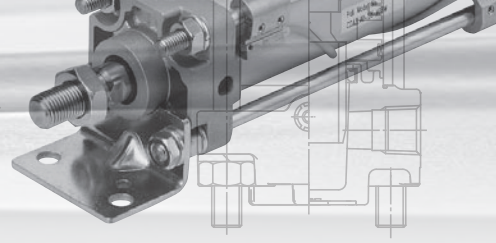

- 1** Cylinder inspection items P.3
- 2** Troubleshooting P.4
- 3** Details of replacement parts

CJP2	Pin Cylinder/Double Acting, Single Rod	P.6
CJP	Pin Cylinder/Single Acting, Spring Return	P.7
CM2	Air Cylinder/Standard Type: Double Acting, Single Rod	P.8
CM2W	Air Cylinder/Standard Type: Double Acting, Double Rod	P.9
CM2	Air Cylinder/Standard Type: Single Acting, Spring Return/Extend	P.10
CM2K	Air Cylinder/Non-rotating Rod Type: Double Acting, Single Rod	P.11
CM2KW	Air Cylinder/Non-rotating Rod Type: Double Acting, Double Rod	P.12
CM2K	Air Cylinder/Non-rotating Rod Type: Single Acting, Spring Return/Extend	P.13
CM2R	Air Cylinder/Direct Mount Type: Double Acting, Single Rod	P.14
CM2RK	Air Cylinder/Direct Mount, Non-rotating Rod Type: Double Acting, Single Rod	P.15
CM2□P	Air Cylinder/Centralized Piping Type: Double Acting, Single Rod	P.16
CBM2	Air Cylinder/With End Lock	P.17
CG1	Air Cylinder/Standard Type: Double Acting, Single Rod	P.18
CG1W	Air Cylinder/Standard Type: Double Acting, Double Rod	P.19
CG1	Air Cylinder/Standard Type: Single Acting, Spring Return/Extend	P.20
CG1K	Air Cylinder/Non-rotating Rod Type: Double Acting, Single Rod	P.21
CG1KW	Air Cylinder/Non-rotating Rod Type: Double Acting, Double Rod	P.22
CG1R	Air Cylinder/Direct Mount Type: Double Acting, Single Rod	P.23
CG1KR	Air Cylinder/Direct Mount, Non-rotating Rod Type: Double Acting, Single Rod	P.24
CBG1	Air Cylinder/With End Lock	P.25
CG3	Air Cylinder Short Type Standard/Double Acting, Single Rod	P.26
MB	Air Cylinder/Single Rod	P.27
MBW	Air Cylinder/Double Rod	P.28
MBK	Air Cylinder/Non-rotating Rod Type	P.29
MB□Q	Air Cylinder/Low Friction Type	P.30
MBB	Air Cylinder/With End Lock	P.31
MB1	Square Tube Type Air Cylinder/Standard Type: Double Acting, Single Rod	P.32
MB1W	Square Tube Type Air Cylinder/Standard Type: Double Acting, Double Rod	P.33
MB1K	Square Tube Type Air Cylinder/Non-rotating Rod Type: Double Acting, Single Rod	P.34
CA2	Air Cylinder/Standard Type: Double Acting, Single Rod	P.35
CA2W	Air Cylinder/Standard Type: Double Acting, Double Rod	P.36
CA2K	Air Cylinder/Non-rotating Rod Type: Double Acting, Single Rod	P.37
CA2KW	Air Cylinder/Non-rotating Rod Type: Double Acting, Double Rod	P.38
CBA2	Air Cylinder/With End Lock	P.39
CA2□H	Air-hydro Cylinder/Double Acting, Single Rod	P.40
CA2W□H	Air-hydro Cylinder/Double Acting, Double Rod	P.41
CS1	Air Cylinder/Standard Type: Lube, Non-lube Type, Air-hydro Type	P.42
CDS1	Air Cylinder/With auto switch	P.43
CS1W	Air Cylinder/Double Rod Type	P.44
CS1□Q	Air Cylinder/Low Friction Type: Non-lube Type	P.45
CS2	Air Cylinder	P.46
CS2W	Air Cylinder/Double Rod	P.47
CS2Y	Smooth Cylinder	P.48
CUJ	Mini Free Mount Cylinder	P.49
CU	Free Mount Cylinder/Double Acting: Single Rod	P.51
CUW	Free Mount Cylinder/Double Acting: Double Rod	P.52
CU	Free Mount Cylinder/Single Acting, Spring Return/Extend	P.53
CUK	Free Mount Cylinder/Non-rotating Rod Type: Double Acting, Single Rod	P.55
CUKW	Free Mount Cylinder/Non-rotating Rod Type: Double Acting, Double Rod	P.56
CUK	Free Mount Cylinder/Non-rotating Rod Type: Single Acting, Spring Return/Extend	P.57

CU	Free Mount Cylinder/Long Stroke Type: Double Acting, Single Rod	P.59
CUK	Free Mount Cylinder/Long Stroke Type: Non-rotating Rod, Double Acting, Single Rod	P.60
CU	Free Mount Cylinder with Air Cushion	P.61
ZCUK	Free Mount Cylinder for Vacuum	P.62
CQS	Compact Cylinder/Standard Type: Double Acting, Single Rod	P.64
CQSW	Compact Cylinder/Standard Type: Double Acting, Double Rod	P.65
CQS	Compact Cylinder/Standard Type: Single Acting, Single Rod	P.66
CQSK	Compact Cylinder/Non-rotating Rod Type: Double Acting, Single Rod	P.67
CQSKW	Compact Cylinder/Non-rotating Rod Type: Double Acting, Double Rod	P.68
CQS□S	Compact Cylinder/Anti-lateral Load Type	P.69
CQ2	Compact Cylinder/Standard: Double Acting, Single Rod	P.70
CQ2W	Compact Cylinder/Standard: Double Acting, Double Rod	P.71
CQ2	Compact Cylinder/Standard: Single Acting, Single Rod	P.72
CQ2	Compact Cylinder/Large Bore Size: Double Acting, Single Rod	P.73
CQ2W	Compact Cylinder/Large Bore Size: Double Acting, Double Rod	P.74
CQ2	Compact Cylinder/Long Stroke: Double Acting, Single Rod	P.75
CQ2K	Compact Cylinder/Non-rotating Rod: Double Acting, Single Rod	P.76
CQ2KW	Compact Cylinder/Non-rotating Rod: Double Acting, Double Rod	P.77
CQP2	Compact Cylinder/Axial Piping: Double Acting, Single Rod	P.78
CQP2	Compact Cylinder/Axial Piping: Single Acting, Single Rod	P.79
CQ2	Compact Cylinder/Anti-lateral Load	P.80
CBQ2	Compact Cylinder/With End Lock	P.81
CQ2	Compact Cylinder/Water Resistant: Double Acting, Single Rod	P.82
RQ	Compact Cylinder with Air Cushion	P.83
CQU	Compact Cylinder/Plate Type: Double Acting, Single Rod	P.84
MU	Plate Cylinder/Double Acting: Single Rod	P.85
MUW	Plate Cylinder/Double Acting: Double Rod	P.86
MU	Plate Cylinder/Single Acting: Spring Return/Extend	P.87
CG5-S	Stainless Steel Cylinder	P.88
HYQ	Hygienic Design Cylinder/Basic Type	P.89
HYC	Hygienic Design Cylinder/ISO Standard Type	P.90
HYG	Hygienic Design Cylinder	P.91
MY1B	Mechanically Jointed Rodless Cylinder/Basic Type	P.92
MY1B-□Z	Mechanically Jointed Rodless Cylinder/Basic Type	P.94
MY1H-□Z	Mechanically Jointed Rodless Cylinder/Linear Guide Type	P.95
MY1M	Mechanically Jointed Rodless Cylinder/Slide Bearing Guide Type	P.97
MY1C	Mechanically Jointed Rodless Cylinder/Cam Follower Guide Type	P.98
MY1H	Mechanically Jointed Rodless Cylinder/Linear Guide Type	P.99
MY1□W	Mechanically Jointed Rodless Cylinder/With Protective Cover: Slide Bearing Guide Type, Cam Follower Guide Type	P.102
MY2C	Mechanically Jointed Rodless Cylinder/Cam Follower Guide Type	P.103
MY2H	Mechanically Jointed Rodless Cylinder/Linear Guide/Single Axis Type	P.104
MY2HT	Mechanically Jointed Rodless Cylinder/Linear Guide/Double Axis Type	P.104
MY3A	Mechanically Jointed Rodless Cylinders/Basic Type	P.105
MY3B	Mechanically Jointed Rodless Cylinders/Basic Type	P.107
MY3M	Mechanically Jointed Rodless Cylinders/Slide Bearing Guide Type	P.109
CY3B	Magnetically Coupled Rodless Cylinder/Basic Type	P.110
CY3R	Magnetically Coupled Rodless Cylinder/Direct Mount Type	P.111
CY1S	Magnetically Coupled Rodless Cylinder/Slider Type: Slide Bearing	P.113
CY1L	Magnetically Coupled Rodless Cylinder/Slider Type: Ball Bushing Bearing	P.114
CY1H	Magnetically Coupled Rodless Cylinder/Linear Guide Type	P.115

Actuators

Modular F.R.L.
Pressure Control Equipment

Air Preparation
Equipment

Industrial Filters

Replacement
Procedure

Actuators

Modular F.R.L.
Pressure Control Equipment

Industrial Filters

Actuators 2

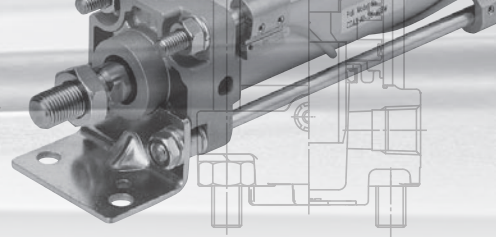

3 Details of replacement parts

MXS	Air Slide Table	P.117
MXQ	Air Slide Table	P.118
MXQR	Air Slide Table/Reversible Type	P.119
MXF	Low Profile Slide Table	P.120
MXW	Air Slide Table	P.121
MPX	Air Slide Table	P.122
MPY	Air Slide Table	P.124
MGP-□Z	Compact Guide Cylinder	P.125
MGP	Compact Guide Cylinder	P.126
MGP	Compact Guide Cylinder/With Air Cushion	P.127
MGP	Compact Guide Cylinder/With End Lock	P.128
MGPS	Compact Guide Cylinder/Heavy Duty Guide Rod Type	P.129
MGPW	Compact Guide Cylinder/Wide Type	P.130
MGQ	Compact Guide Cylinder/With Air Cushion	P.131
MGG	Guide Cylinder	P.132
MGG	Guide Cylinder/With End Lock	P.134
MGC	Guide Cylinder/Compact Type	P.135
MGF	Guide Table	P.136
MGZ	Non-rotating Double Power Cylinder	P.137
MGZ	Non-rotating Double Power Cylinder/With End Lock on Rod Side	P.138
MGZR	Double Power Cylinder/Without Non-rotating Mechanism	P.139
CX2	Slide Unit/Double Rod Type	P.140
CXWM	Slide Unit/Built-in Shock Absorber/Slide Bearing Type	P.141
CXWL	Slide Unit/Built-in Shock Absorber/Ball Bushing Bearing Type	P.143
CXT	Platform Cylinder	P.145
CXSJ	Dual Rod Cylinder/Compact Type	P.146
CXS	Dual Rod Cylinder/Basic Type	P.148
CXS	Dual Rod Cylinder/With Air Cushion	P.150
CXS	Dual Rod Cylinder/With End Lock for Retraction Side	P.151
CXSW	Dual Rod Cylinder/Double Rod Type	P.152
CLG1	Fine Lock Cylinder/Double Acting, Single Rod	P.153
CL1	Lock-up Cylinder/Double Acting, Single Rod	P.154
CNG	Cylinder with Lock/Double Acting, Single Rod	P.155
MNB	Cylinder with Lock/Double Acting, Single Rod	P.156
MNBW	Cylinder with Lock/Double Acting, Double Rod	P.157
CNA2	Cylinder with Lock/Double Acting, Single Rod	P.158
CNA2W	Cylinder with Lock/Double Acting, Double Rod	P.159
CNS	Cylinder with Lock/Double Acting, Single Rod	P.160
CLS	Cylinder with Lock/Double Acting, Single Rod	P.161
REAR	Sine Rodless Cylinder/Direct Mount Type	P.162
REAS	Sine Rodless Cylinder/Slider Type: Slide Bearing	P.164
REAL	Sine Rodless Cylinder/Slider Type: Ball Bushing Bearing	P.166
REAH	Sine Rodless Cylinder/Linear Guide Type	P.168
REBR	Sine Rodless Cylinder/Direct Mount Type	P.171
REBH	Sine Rodless Cylinder/Linear Guide Type	P.172
REC	Sine Cylinder	P.174

RHC	High Power Cylinder	P.175
RZQ	3 Position Cylinder	P.176
MK	Rotary Clamp Cylinder/Standard	P.177
MK2T	Rotary Clamp Cylinder/Double Guide Type	P.178
CKQGPD	Pin Clamp Cylinder D series	P.179
CKQGPU	Pin Clamp Cylinder U series	P.180
CKQGPK	Pin Clamp Cylinder K series	P.181
CKQGPM	Pin Clamp Cylinder M series	P.182
CKQG/CKQP	Guide Pin Assembly/Clamp Arm Assembly	P.183
CKQG32	Pin Clamp Cylinder/Compact Cylinder Type	P.184
CKU32	Pin Clamp Cylinder/Plate Cylinder Type	P.185
CKG1	Clamp Cylinder with Magnetic Field Resistant Auto Switch (Rod Mounting Style)	P.186
CKP1	Clamp Cylinder with Magnetic Field Resistant Auto Switch (Rod Mounting Style)	P.186
CK1	Clamp Cylinder/Magnetic Field Resistant Auto Switch (Band Mounting Style)	P.187
CKG1	Clamp Cylinder/Magnetic Field Resistant Auto Switch (Band Mounting Style)	P.187
RSQ	Stopper Cylinder/Fixed Mounting Height	P.188
RSG	Stopper Cylinder/Adjustable Mounting Height	P.189
RSH	Heavy Duty Stopper Cylinder	P.190
RS2H	Heavy Duty Stopper Cylinder	P.191
MIW	Escapements/Double finger type	P.192
MIS	Escapements/Single finger type	P.193
CVQ	Compact Cylinder/With Solenoid Valve	P.194
CVM5	Valve Mounted Cylinder/Double Acting, Single Rod	P.195
CVM5K	Valve Mounted Cylinder/Non-rotating Rod Type: Double Acting	P.196
CVM3	Valve Mounted Cylinder/Single Acting, Spring Return/Extend	P.197
CVM3K	Valve Mounted Cylinder/Non-rotating Rod Type: Single Acting, Spring Return/Extend	P.198
CV3	Valve Mounted Cylinder/Double Acting	P.199
CV3K	Valve Mounted Cylinder/Non-rotating Rod Type: Double Acting	P.200
CVS1	Valve Mounted Cylinder/Double Acting	P.201
CVS1K	Valve Mounted Cylinder/Non-rotating Rod Type: Double Acting	P.202
CH□QB	Compact Hydraulic Cylinder/Double Acting, Single Rod	P.203
CH□QWB	Compact Hydraulic Cylinder/Double Acting, Double Rod	P.204
CH□KD	JIS Standard Compact Hydraulic Cylinder	P.205
CH□KG	Compact Hydraulic Cylinder	P.206
CHN	Hydraulic Cylinder	P.207
CHSD	ISO Standard Hydraulic Cylinder	P.208
CHSG	ISO Standard Hydraulic Cylinder	P.209
CH2E	JIS Standard Hydraulic Cylinder/Double Acting, Single Rod	P.210
CH2F	JIS Standard Hydraulic Cylinder/Double Acting, Single Rod	P.210
CH2G	JIS Standard Hydraulic Cylinder/Double Acting, Single Rod	P.210
CH2H	JIS Standard Hydraulic Cylinder/Double Acting, Single Rod	P.210
CH2EW	JIS Standard Hydraulic Cylinder/Double Acting, Double Rod	P.211
CH2FW	JIS Standard Hydraulic Cylinder/Double Acting, Double Rod	P.211
CHA	Tie-rod Type Hydraulic Cylinder/Double Acting, Single Rod	P.212
CHAW	Tie-rod Type Hydraulic Cylinder/Double Acting, Double Rod	P.213

1 Cylinder inspection items

The following describes the general contents of the cylinder inspection items. Actually, add inspection items suitable for the customer's specifications and perform the inspection work.

■ Inspection items

- 1) Check the cylinder mounting bolt or nut for looseness.
- 2) Check the cylinder mounting frame for looseness or unusual deflection.
- 3) Check the rod end bracket, tie rod, or bolt for looseness or rattle.
- 4) Check the rod for dent or sliding scratch.
- 5) Check that the cylinder operates smoothly and that the minimum operating pressure does not increase.
- 6) Check that the piston speed or cycle time does not change.
- 7) Check that any shock does not occur at the operation end or that any unusual noise is not heard.
- 8) Check for eternal leak. In particular, carefully check the rod seal.
- 9) Check that the stroke is correct and that the cylinder operates the specified stroke.
- 10) Check that the auto switch operates correctly, that the switch joint is not loose, and that the switch position does not deviate.

■ Trouble judgement from cylinder status (Judgement from appearance)

- 1) **Only one side of the rod surface is contaminated blackly.**
→ The seal is worn out unevenly by the eccentric load or lateral load.
- 2) **Thin sliding scratch is marked on the entire periphery of the rod in the operation direction.**
→ The lubrication is faulty due to grease run-out.
- 3) **Sliding scratch is marked on only one side of the rod surface.**
→ The rod is strongly in contact with the bushing by the eccentric load or lateral load, causing scratch.
- 4) **A part of the rod is scratched in a direction perpendicular to the cylinder operation.**
→ A large lateral load is applied when the cylinder stops.
- 5) **Air leaks from the rod seal.**
→ Scratch, dent, eccentric load, or external foreign object (solid or liquid) may be the cause.

■ Probable troubles (Reference)

Refer to the cylinder troubleshooting. (P.4)

Actuators

2 Troubleshooting

The following describes the general contents of the troubleshooting.

[Cylinder]

Trouble (Symptom)	Cause	Corrective action
The operation is not smooth. The output drops. The cylinder does not operate.	The grease of the sliding part runs out.	Apply the grease. The following may be the cause of the trouble. <ul style="list-style-type: none"> • As water content, such as drain enters, the grease flows out. • The lubrication is stopped halfway. • The cylinder is operated in an environment where the fluid splashes.
	The center between the workpiece and cylinder shaft or the center between the workpiece guide shaft and cylinder shaft deviates.	Align the center. Check that the cylinder operates smoothly with the air not supplied to the cylinder. Additionally, examine the use of the floating joint.
	The piston rod deforms.	Replace the cylinder. The following may be the cause of the trouble. <ul style="list-style-type: none"> • The center between the cylinder and load deviates. • A lateral load exceeding an allowable level is applied. • The kinetic energy exceeds an allowable level. • An excessive force is applied when mounting a load.
	The air leaks (seal is worn-out).	Replace the seal. The following may be the cause of the trouble. <ul style="list-style-type: none"> • The center between the cylinder and load deviates. • A lateral load exceeding an allowable level is applied. • The operating temperature exceeds its range. • The grease runs out. • A foreign object enters.
	The air pressure is insufficient.	Supply an appropriate pressure. The following may be the cause of the trouble. <ul style="list-style-type: none"> • The supply pressure decreases. • The pressure regulator setting deviates. • The piping is clogged.
	The cylinder operates at low speed.	Operate the cylinder within the specification range.
	The cylinder output is insufficient.	Increase the operating pressure or use an appropriate cylinder with a large bore size. Since there are cylinder and mechanical resistances, it is necessary to consider the load factor.
	The system configuration is not appropriate.	Use piping tube, fitting, directional control valve, and speed controller with proper sizes.
	Equipment other than the cylinder malfunctions or is faulty.	Investigate the target system step-by-step. The following may be the cause of the trouble. <ul style="list-style-type: none"> • The directional control valve malfunctions. • The speed controller is not adjusted properly. • The speed controller malfunctions. • The piping is clogged. • The filter is clogged, etc.
The cylinder part is damaged.	The cylinder operates at high speed.	Adjust the speed with the speed controller to operate the cylinder within the specification range.
	Overload	Operate the cylinder within its allowable kinetic energy range.
	Lateral load	Operate the cylinder within its lateral load range.
	Unusual external force is applied.	If any mechanical interference, eccentric load, or overload occurs, this may cause the cylinder to deform or break. Remove such adverse factors.

Industrial Filters

Modular F.R.L.
Pressure Control Equipment

Actuators

Replacement
Procedure

Industrial Filters

Air Preparation
Equipment

Modular F.R.L.
Pressure Control Equipment

Actuators

Series CJP2

ø6, ø10, ø16



Construction

C□JP2B6

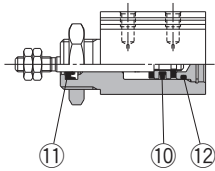

C□JP2B10, 16

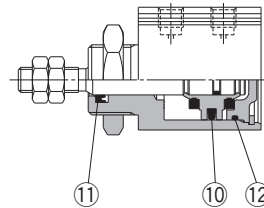

* The numbers are the same as the "Construction" of the Best Pneumatics No.2 Series CJP2.

Seal Kit List

No.	Description	Material	Note
⑩	Piston seal	NBR	
⑪	Rod seal	NBR	
⑫	Gasket	ø6, ø10, ø16	NBR

Replacement Parts: Seal Kit

Bore size (mm)	Kit no.	Contents
----------------	---------	----------

Standard

6	CJP2B6D-PS	Set of left nos. ⑩, ⑪, ⑫.
10	CJP2B10D-PS	
16	CJP2B16D-PS	

* Seal kit includes a grease pack (5 g).

Order with the following part number when only the grease pack is needed.

Grease pack part number: GR-L-005 (5 g)

XB6/Heat-resistant cylinder (-10 to 150°C)

6	CJP2B6D-XB6-PS	Set of left nos. ⑩, ⑪, ⑫.
10	CJP2B10D-XB6-PS	
16	CJP2B16D-XB6-PS	

* Seal kit includes a grease pack (5 g).

Order with the following part number when only the grease pack is needed.

Grease pack part number: GR-F-005 (5 g)

XB7/Cold-resistant cylinder

6	CJP2B6D-XB7-PS	Set of left nos. ⑩, ⑪, ⑫.
10	CJP2B10D-XB7-PS	
16	CJP2B16D-XB7-PS	

* Seal kit includes a grease pack (5 g).

Order with the following part number when only the grease pack is needed.

Grease pack part number: GR-T-005 (5 g)

XC22/Fluororubber seal

6	CJP2B6D-XC22-PS	Set of left nos. ⑩, ⑪, ⑫.
10	CJP2B10D-XC22-PS	
16	CJP2B16D-XC22-PS	

* Seal kit includes a grease pack (5 g).

Order with the following part number when only the grease pack is needed.

Grease pack part no.: GR-L-005 (5 g)

Series CJP

ø4, ø6, ø10, ø15

Construction (Not able to disassemble.)

Embedded type

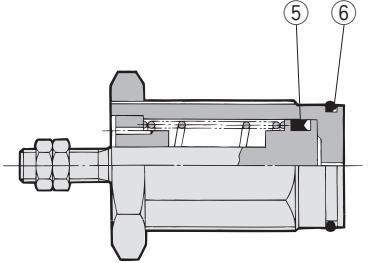

* The numbers are the same as the "Construction" of the Best Pneumatics No.2 Series CJP.

Seal List

No.	Description	Material	Note
5	Piston seal		5 is a non-replaceable part
⑥	Gasket	NBR	Special product (O-ring) embedded type only

Replacement Parts/Gasket

Bore size (mm)	Order no.	Contents
4	CJPS4-G	Left no. ⑥
6	CJPS6-G	
10	CJPS10-G	
15	CJPS15-G	

* For the plug mounting style
 * Since gaskets (10 pcs./set) do not include a grease pack (10 g), order it separately.
Grease pack part no.: GR-S-005 (5 g)

Actuators

Modular F.R.L.
Pressure Control Equipment

Air Preparation
Equipment

Industrial Filters

Replacement
Procedure

Actuators

Modular F.R.L.
Pressure Control Equipment

Industrial Filters

Series CM2

ø20, ø25, ø32, ø40

Replacement
Procedure is
P.280

Construction

Rubber bumper

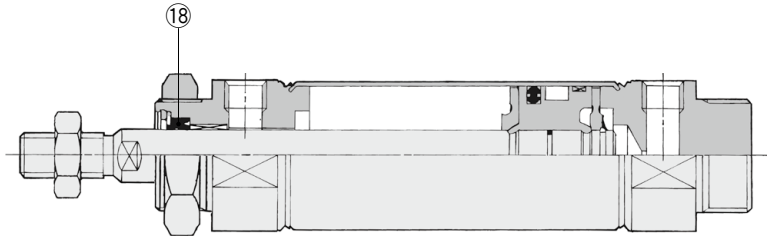

Air-hydro

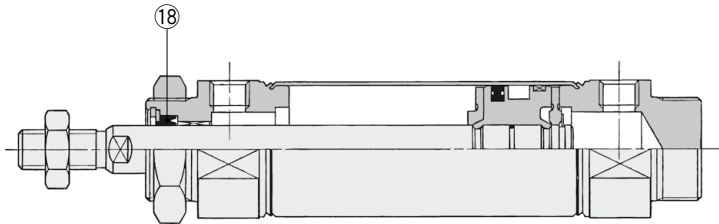

With air cushion

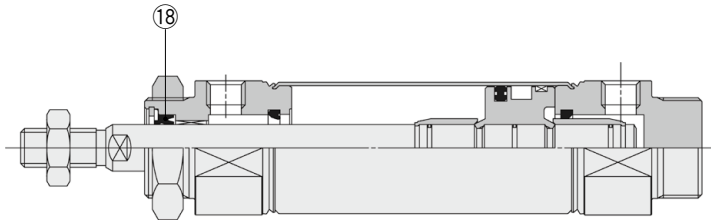

Built-in One-touch fittings

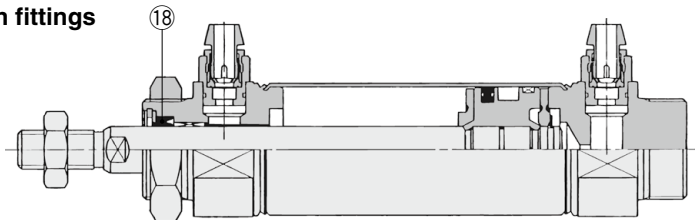

* The numbers are the same as the "Construction" of the Best Pneumatics No.2 Series CM2.

Seal Kit List

No.	Description	Material	Note
18	Rod seal	NBR	

Replacement Part: Seal

With rubber bumper, with air cushion, built-in One-touch fittings

Bore size (mm)	Kit no.	Contents
20	CM220-PS	
25	CM225-PS	
32	CM232-PS	
40	CM240-PS	

Air-hydro

Bore size (mm)	Kit no.	Contents
20	CM2H20-PS	
25	CM2H25-PS	
32	CM2H32-PS	
40	CM2H40-PS	

* Since the seal kit does not include a grease pack, order it separately.
Grease pack part no.: GR-S-010 (10 g)

Series CM2W

ø20, ø25
ø32, ø40

Replacement
Procedure is
P.280

Construction

Rubber bumper

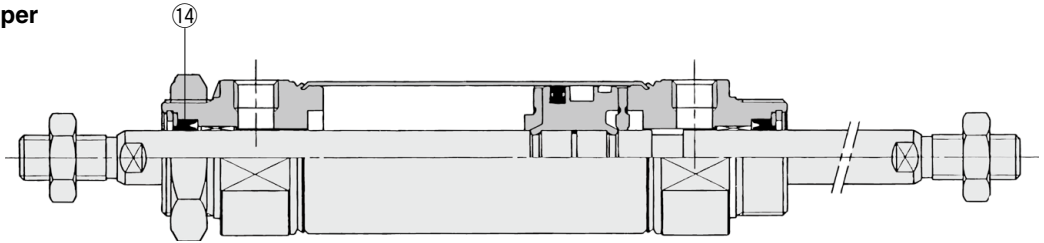

Air-hydro

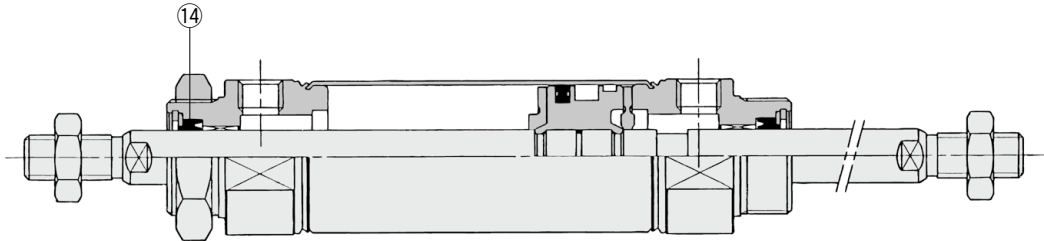

With air cushion

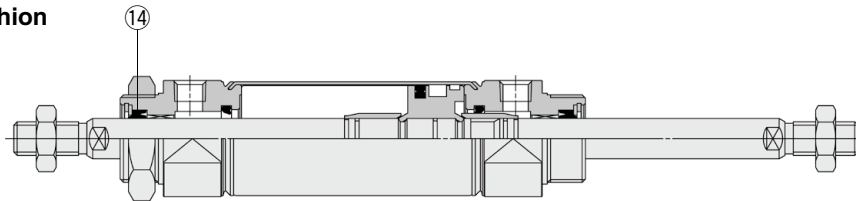

Built-in One-touch fittings

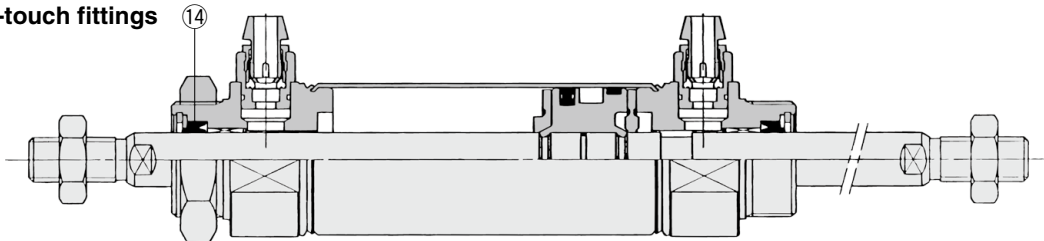

* The numbers are the same as the "Construction" of the Best Pneumatics No.2 Series CM2W.

Seal Kit List

No.	Description	Material	Note
14	Rod seal	NBR	

Replacement Part: Seal

With rubber bumper, with air cushion, built-in One-touch fittings

Bore size (mm)	Kit no.	Contents
20	CM220-PS	
25	CM225-PS	
32	CM232-PS	
40	CM240-PS	

Air-hydro

Bore size (mm)	Kit no.	Contents
20	CM2H20-PS	
25	CM2H25-PS	
32	CM2H32-PS	
40	CM2H40-PS	

* Since the seal kit does not include a grease pack, order it separately.

Grease pack part no.: GR-S-010 (10 g)

* 2 pcs. are required per cylinder.

Actuators

Modular F.R.L.
Pressure Control Equipment

Air Preparation
Equipment

Industrial Filters

Replacement
Procedure

Actuators

Modular F.R.L.
Pressure Control Equipment

Industrial Filters

Series CM2

ø20, ø25, ø32, ø40

Replacement
Procedure is
P.280

Construction

Spring return

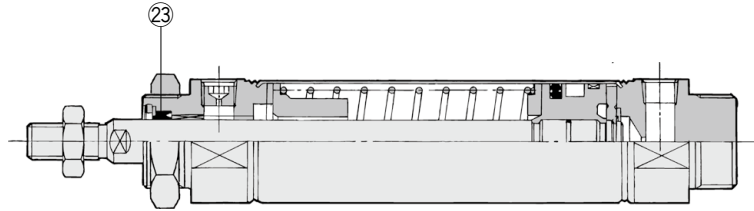

Spring return, built-in One-touch fittings

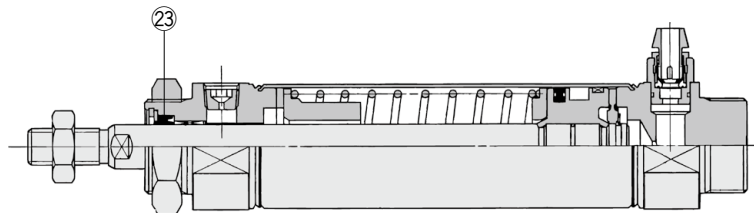

Spring extend

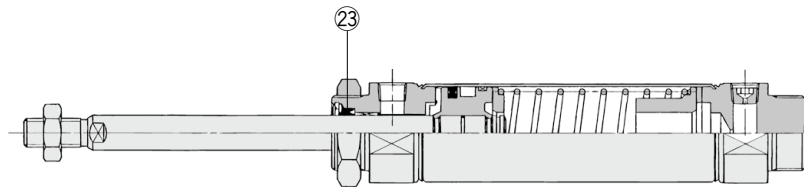

Spring extend, built-in One-touch fittings

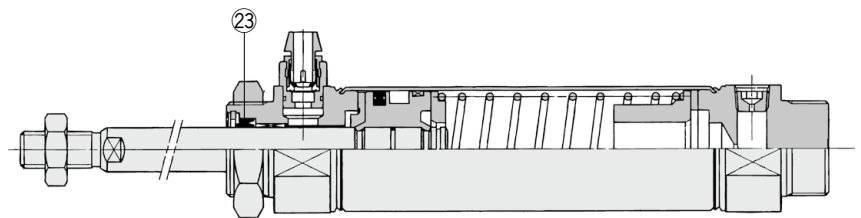

* The numbers are the same as the "Construction" of the Best Pneumatics No.2 Series CM2.

Seal Kit List

No.	Description	Material	Note
23	Rod seal	NBR	

Replacement Parts: Seal With rubber bumper, built-in One-touch fittings

Bore size (mm)	Kit no.	Contents
20	CM220-PS	
25	CM225-PS	
32	CM232-PS	
40	CM240-PS	

* Since the seal kit does not include a grease pack, order it separately.
Grease pack part no.: GR-S-010 (10 g)

Air Cylinder/Non-rotating Rod Type: Double Acting, Single Rod

Series CM2K

ø20, ø25, ø32, ø40

Replacement
Procedure is
P.280

Construction

Rubber bumper

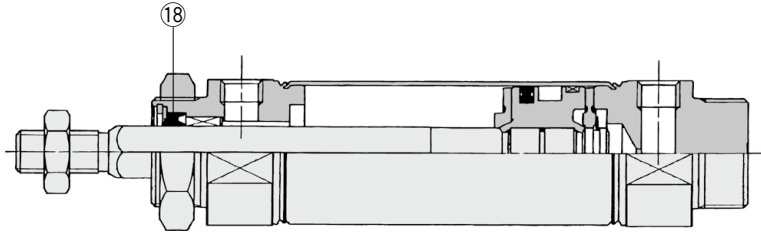

With air cushion

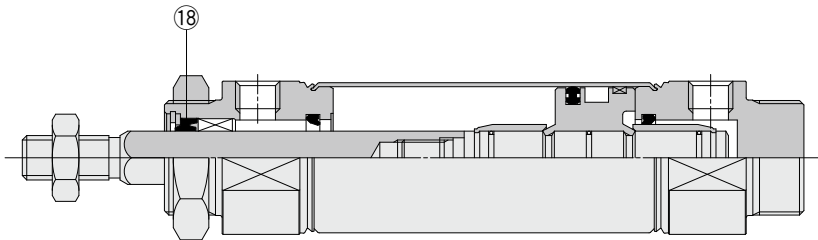

* The numbers are the same as the "Construction" of the Best Pneumatics No.2 Series CM2K.

Seal Kit List

No.	Description	Material	Note
18	Rod seal	NBR	

Replacement Parts: Seal With rubber bumper, with air cushion

Bore size (mm)	Kit no.	Contents
20	CM2K20-PS	
25	CM2K25-PS	
32	CM2K32-PS	
40	CM2K40-PS	

* Since the seal kit does not include a grease pack, order it separately.
Grease pack part no.: GR-S-010 (10 g)

Actuators

Modular F.R.L.
Pressure Control Equipment

Air Preparation
Equipment

Industrial Filters

Replacement
Procedure

Actuators

Modular F.R.L.
Pressure Control Equipment

Industrial Filters

Series CM2KW

ø20, ø25
ø32, ø40

Replacement
Procedure is
P.280

Construction

Rubber bumper

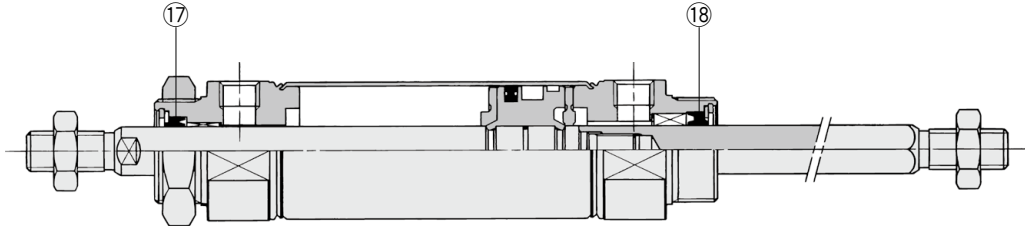

With air cushion

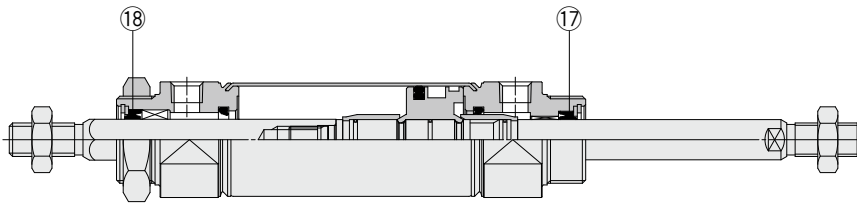

* The numbers are the same as the "Construction" of the Best Pneumatics No.2 Series CM2KW.

Seal Kit List

No.	Description	Material	Note
⑰	Rod seal A	NBR	
⑱	Rod seal B		

Replacement Parts: Seal

With rubber bumper, with air cushion, built-in One-touch fittings

Bore size (mm)	Kit no.		Contents
	Rod seal A	Rod seal B	
20	CM220-PS	CM2K20-PS	
25	CM225-PS	CM2K25-PS	
32	CM232-PS	CM2K32-PS	
40	CM240-PS	CM2K40-PS	

* Since the seal kit does not include a grease pack, order it separately.

Grease pack part no.: GR-S-010 (10 g)

Series CM2K

ø20, ø25, ø32, ø40

Replacement Procedure is P.280

Construction

Spring return

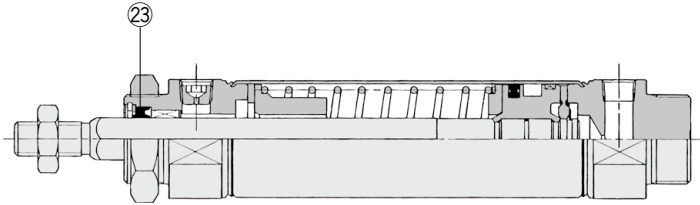

Spring extend

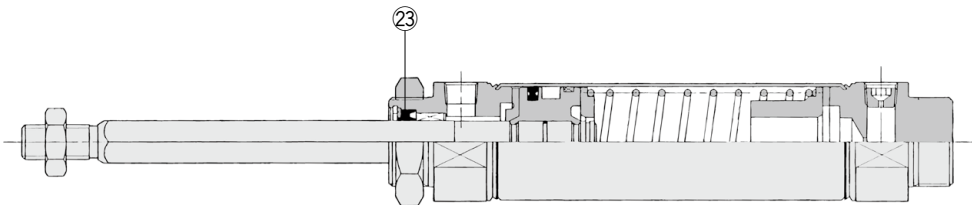

* The numbers are the same as the "Construction" of the Best Pneumatics No.2 Series CM2K.

Seal Kit List

No.	Description	Material	Note
23	Rod seal	NBR	

Replacement Parts: Seal

Bore size (mm)	Kit no.	Contents
20	CM2K20-PS	
25	CM2K25-PS	
32	CM2K32-PS	
40	CM2K40-PS	

* Since the seal kit does not include a grease pack, order it separately.
Grease pack part no.: GR-S-010 (10 g)

Actuators

Modular F.R.L.
Pressure Control Equipment

Air Preparation
Equipment

Industrial Filters

Replacement
Procedure

Actuators

Modular F.R.L.
Pressure Control Equipment

Industrial Filters

Air Cylinder/Direct Mount Type: Double Acting, Single Rod

Series *CM2R*

ø20, ø25, ø32, ø40

Replacement
Procedure is
P.280

Construction

Rubber bumper

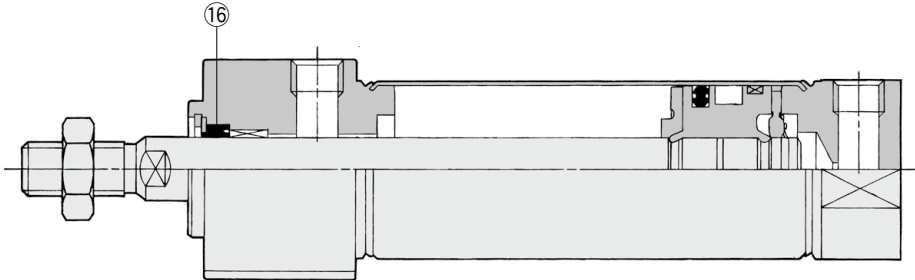

Air-hydro

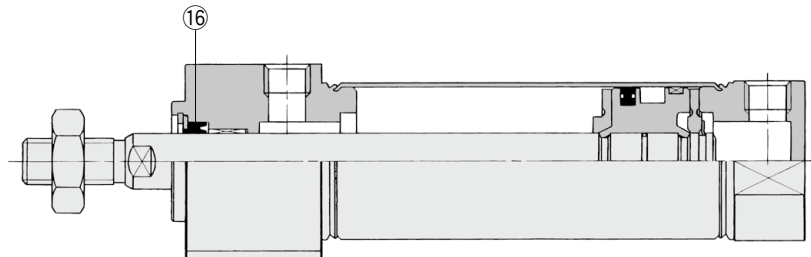

With air cushion

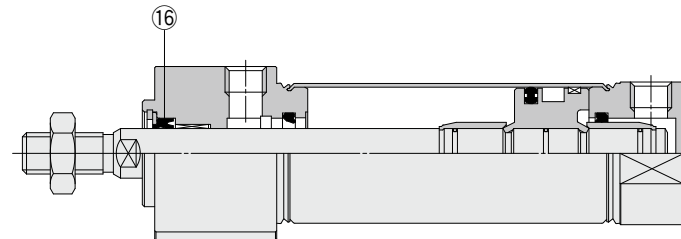

* The numbers are the same as the "Construction" of the Best Pneumatics No.2 Series CM2R.

Seal Kit List

No.	Description	Material	Note
16	Rod seal	NBR	

Replacement Parts: Seal

With rubber bumper, with air cushion

Bore size (mm)	Kit no.	Contents
20	CM220-PS	
25	CM225-PS	
32	CM232-PS	
40	CM240-PS	

Air-hydro

Bore size (mm)	Kit no.	Contents
20	CM2H20-PS	
25	CM2H25-PS	
32	CM2H32-PS	
40	CM2H40-PS	

* Since the seal kit does not include a grease pack, order it separately.
Grease pack part no.: GR-S-010 (10 g)

Series CM2RK

∅20, ∅25
∅32, ∅40

Replacement
Procedure is
P.280

Construction

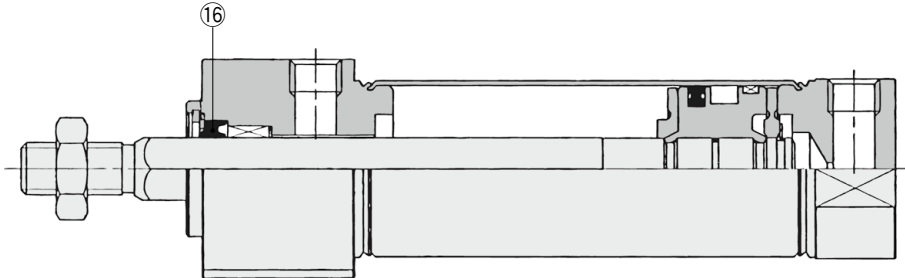

* The numbers are the same as the "Construction" of the Best Pneumatics No.2 Series CM2RK.

Seal Kit List

No.	Description	Material	Note
16	Rod seal	NBR	

Replacement Parts: Seal

Bore size (mm)	Kit no.	Contents
20	CM2K20-PS	
25	CM2K25-PS	
32	CM2K32-PS	
40	CM2K40-PS	

* Since the seal kit does not include a grease pack, order it separately.
Grease pack part no.: GR-S-010 (10 g)

Actuators

Modular F.R.L.
Pressure Control Equipment

Air Preparation
Equipment

Industrial Filters

Replacement
Procedure

Actuators

Modular F.R.L.
Pressure Control Equipment

Industrial Filters

Series CM2□P

ø20, ø25
ø32, ø40

Replacement
Procedure is
P.280

Construction

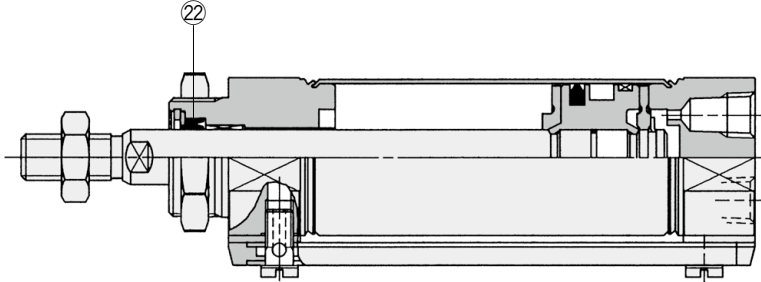

* The numbers are the same as the "Construction" of the Best Pneumatics No.2 Series CM2□P.

Seal Kit List

No.	Description	Material	Note
22	Rod seal	NBR	

Replacement Parts: Seal

Bore size (mm)	Kit no.	Contents
20	CM220-PS	
25	CM225-PS	
32	CM232-PS	
40	CM240-PS	

* Since the seal kit does not include a grease pack, order it separately.
Grease pack part no.: GR-S-010 (10 g)

Series CBM2

ø20, ø25, ø32, ø40



Construction

Head end lock

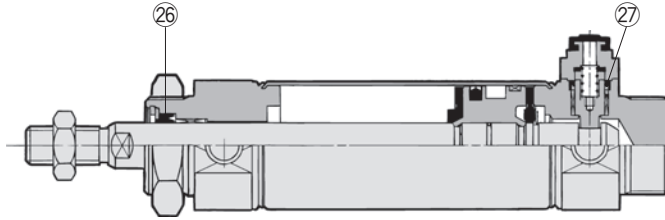

Manual release (Non-lock type): Suffix N

With air cushion

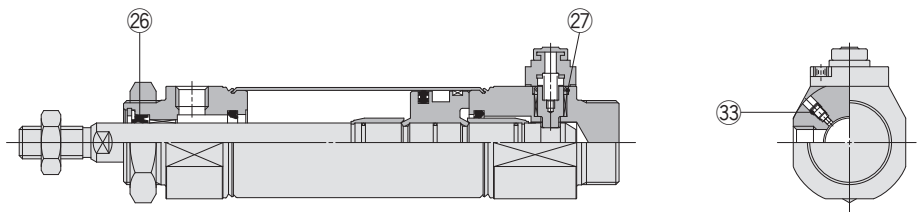

* The numbers are the same as the "Construction" of the Best Pneumatics No.2 Series CBM2.

Seal Kit List

No.	Description	Material	Note
26	Rod seal	NBR	33 is a non-replaceable part, so it is not included in the seal kit.
27	Lock piston seal		
33	Cushion needle seal		

Replacement Parts: Seal Kit

Bore size (mm)	Kit no.	Contents
With lock in single end		
20	CBM2-20-PS	Set of left nos. 26, 27.
25	CBM2-25-PS	
32	CBM2-32-PS	
40	CBM2-40-PS	
With lock at double ends		
20	CBM2-20-PS-W	Set of left nos. 26, 27.
25	CBM2-25-PS-W	
32	CBM2-32-PS-W	
40	CBM2-40-PS-W	

* Seal kit includes 26 and 27. Order the seal kit, based on each bore size. (Except 33.)

* Seal kit includes a grease pack (10 g). Order with the following part number when only the grease pack is needed.

Grease pack part no.: GR-S-010 (10 g)

Actuators

Modular F.R.L.
Pressure Control Equipment

Air Preparation
Equipment

Industrial Filters

Replacement
Procedure

Actuators

Modular F.R.L.
Pressure Control Equipment

Industrial Filters

Series CG1

ø20, ø25, ø32, ø40
ø50, ø63, ø80, ø100

Replacement
Procedure is
P.281

Construction

With rubber bumper

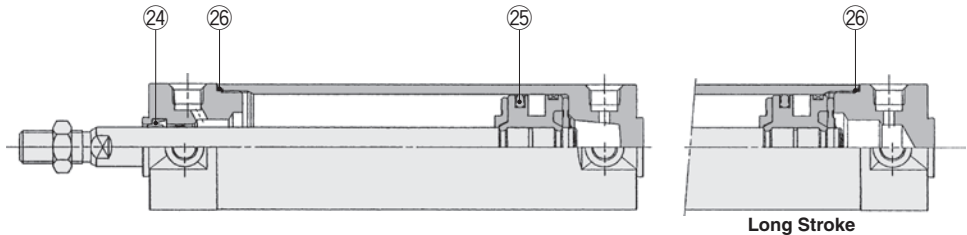

With air cushion

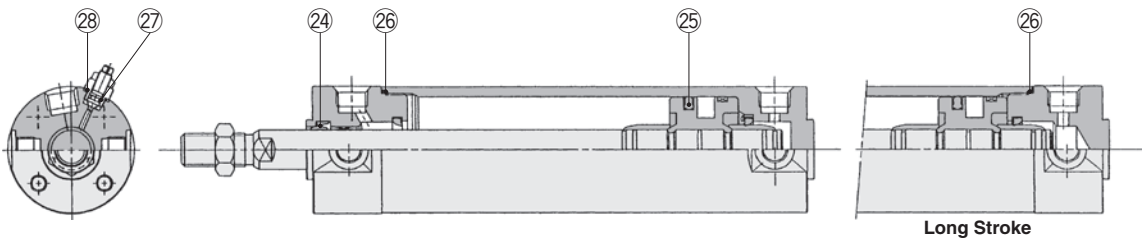

* The numbers are the same as the "Construction" of the Best Pneumatics No.2 Series CG1.

Seal Kit List

No.	Description	Material	Note
24	Rod seal	NBR	
25	Piston seal		
26	Tube gasket		
27	Valve seal		
28	Valve retainer gasket		

Disassembly/Replacement

⚠ Caution

1. Do not replace the bushings.

The bushings are press-fit. To replace them, they must be replaced together with the cover assembly.

2. To replace a seal, apply grease to the new seal before installing it.

If the cylinder is put into operation without applying grease to the seal, it could cause the seal to wear significantly, leading to premature air leakage.

3. Cylinders with ø50 or larger bore sizes cannot be disassembled.

When disassembling cylinders with bore sizes ø20 through ø40, grip the double flat part of either the head cover or the rod cover with a vise and loosen the other side with a wrench or a monkey wrench, etc., and then remove the cover. When re-tightening, tighten approximately 2 degrees more than the original position.

(Cylinders with ø50 or larger bore sizes are tightened with a large tightening torque and cannot be disassembled. If disassembly is required, please contact SMC.)

Replacement Parts: Seal Kit

Bore size (mm)	Kit no.	Contents
With rubber bumper		
20	CG1N20-PS	Set of left nos. 24, 25, 26.
25	CG1N25-PS	
32	CG1N32-PS	
40	CG1N40-PS	
With air cushion		
20	CG1A20-PS	Set of left nos. 24, 25, 26, 27, 28.
25	CG1A25-PS	
32	CG1A32-PS	
40	CG1A40-PS	

Note) Order with a part number for each type and bore size.

* The seal kit includes a grease pack (10 g).

Order with the following part number when only the grease pack is needed.

Grease pack part no.: GR-S-010 (10 g)

Air Cylinder/Standard Type: Double Acting, Double Rod

Series CG1W

ø20, ø25, ø32
ø40, ø50, ø63
ø80, ø100

Replacement
Procedure is
P.281

Construction

With rubber bumper

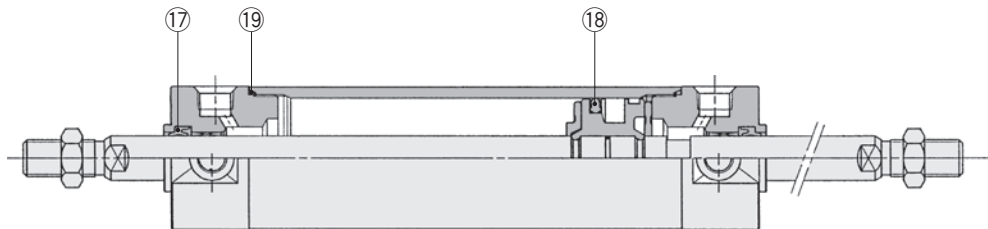

With air cushion

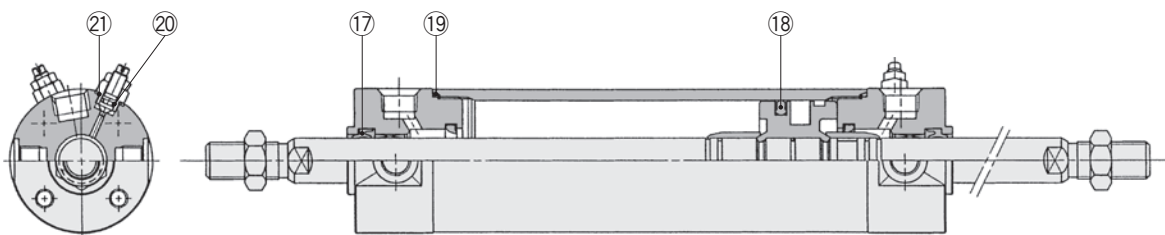

* The numbers are the same as the "Construction" of the Best Pneumatics No.2 Series CG1W.

Seal Kit List

No.	Description	Material	Note
17	Rod seal	NBR	
18	Piston seal		
19	Tube gasket		
20	Valve seal		
21	Valve retainer gasket		

Disassembly/Replacement

⚠ Caution

1. Do not replace the bushings.

The bushings are press-fit. To replace them, they must be replaced together with the cover assembly.

2. To replace a seal, apply grease to the new seal before installing it.

If the cylinder is put into operation without applying grease to the seal, it could cause the seal to wear significantly, leading to premature air leakage.

3. Cylinders with ø50 or larger bore sizes cannot be disassembled.

When disassembling cylinders with bore sizes ø20 through ø40, grip the double flat part of either the rod cover with a vise and loosen the other side with a wrench or a monkey wrench, etc., and then remove the cover. When re-tightening, tighten approximately 2 degrees more than the original position.

(Cylinders with ø50 or larger bore sizes are tightened with a large tightening torque and cannot be disassembled. If disassembly is required, please contact SMC.)

Replacement Parts: Seal Kit

Bore size (mm)	Kit no.	Contents
With rubber bumper		
20	CG1WN20-PS	Set of left nos. 17, 18, 19.
25	CG1WN25-PS	
32	CG1WN32-PS	
40	CG1WN40-PS	
With air cushion		
20	CG1WA20-PS	Set of left nos. 17, 18, 19, 20, 21.
25	CG1WA25-PS	
32	CG1WA32-PS	
40	CG1WA40-PS	

Note) Order with a part number for each type and bore size.

* The seal kit includes a grease pack (10 g).

Order with the following part number when only the grease pack is needed.

Grease pack part no.: GR-S-010 (10 g)

Air Cylinder/Standard Type: Single Acting, Spring Return/Extend

Series CG1

ø20, ø25, ø32, ø40

Replacement
Procedure is
P.281

Construction

Single acting, spring return

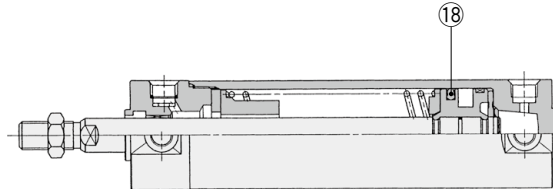

Single acting, spring extend

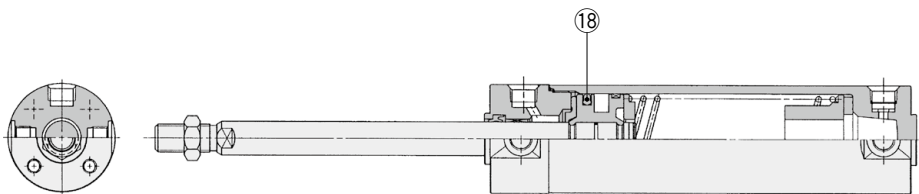

* The numbers are the same as the "Construction" of the Best Pneumatics No.2 Series CG1.

Seal Kit List

No.	Description	Material	Note
18	Piston seal	NBR	

Disassembly/Replacement

⚠ Caution

1. Do not replace the bushings.

The bushings are press-fit. To replace them, they must be replaced together with the cover assembly.

2. To replace a seal, apply grease to the new seal before installing it.

If the cylinder is put into operation without applying grease to the seal, it could cause the seal to wear significantly, leading to premature air leakage.

3. Please note that disassembly by the spring reaction force, because it may cover will pop up. When disassembling cylinders, grip the double flat part of either the head cover or the rod cover with a vise and loosen the other side with a wrench or a monkey wrench, etc., and then remove the cover. When re-tightening, tighten approximately 2 degrees more than the original position.

Replacement Parts: Seal

Bore size (mm)	Kit no.	Contents
20	CG1N20-S-PS	
25	CG1N25-S-PS	
32	CG1N32-S-PS	
40	CG1N40-S-PS	

* Since the seal kit does not include a grease pack, order it separately.
Grease pack part no.: GR-S-010 (10 g)

Single acting, spring extend

* Replacement parts: Seal kit is the same as the case of standard type single rod (with rubber bumper). Refer to page 18.

Air Cylinder/Non-rotating Rod Type: Double Acting, Single Rod

Series CG1K

ø20, ø25, ø32
ø40, ø50, ø63

Replacement
Procedure is
P.281

Construction

With rubber bumper

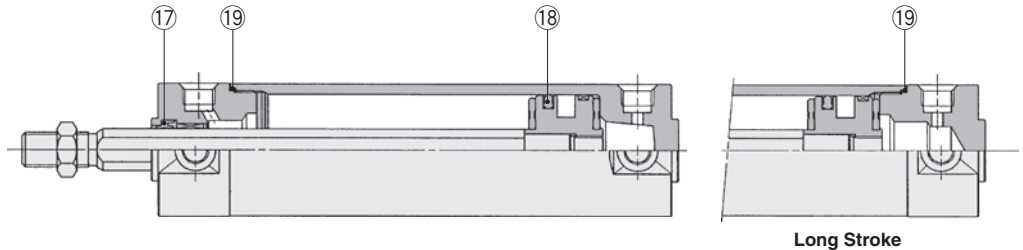

With air cushion

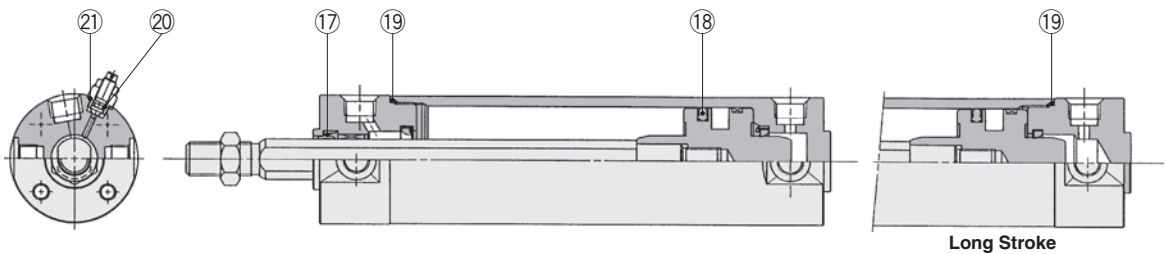

* The numbers are the same as the "Construction" of the Best Pneumatics No.2 Series CG1K.

Seal Kit List

No.	Description	Material	Note
17	Rod seal	NBR	
18	Piston seal		
19	Tube gasket		
20	Valve seal		
21	Valve retainer gasket		

Disassembly/Replacement

⚠ Caution

1. Do not replace the bushings.

The bushings are press-fit. To replace them, they must be replaced together with the cover assembly.

2. To replace a seal, apply grease to the new seal before installing it.

If the cylinder is put into operation without applying grease to the seal, it could cause the seal to wear significantly, leading to premature air leakage.

3. Cylinders with ø50 or larger bore sizes cannot be disassembled.

When disassembling cylinders with bore sizes ø20 through ø40, grip the double flat part of either the head cover or the rod cover with a vise and loosen the other side with a wrench or a monkey wrench, etc., and then remove the cover. When re-tightening, tighten approximately 2 degrees more than the original position.
(Cylinders with ø50 or larger bore sizes are tightened with a large tightening torque and cannot be disassembled. If disassembly is required, please contact SMC.)

Replacement Parts: Seal Kit

Bore size (mm)	Kit no.	Contents
With rubber bumper		
20	CG1KN20-PS	Set of left nos. 24, 25, 26.
25	CG1KN25-PS	
32	CG1KN32-PS	
40	CG1KN40-PS	
With air cushion		
40	CG1KA40-PS	Set of left nos. 24, 25, 26, 27, 28.

Note) Order with a part number for each type and bore size.

* The seal kit includes a grease pack (10 g).

Order with the following part number when only the grease pack is needed.

Grease pack part no.: GR-S-010 (10 g)

Air Cylinder/Non-rotating Rod Type: Double Acting, Double Rod

Series CG1KW

ø20, ø25
ø32, ø40
ø50, ø63

Replacement
Procedure is
P.281

Construction

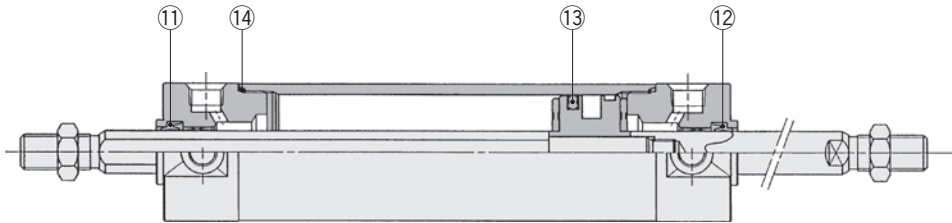

* The numbers are the same as the "Construction" of the Best Pneumatics No.2 Series CG1KW.

Seal Kit List

No.	Description	Material	Note
⑪	Rod seal A	NBR	
⑫	Rod seal B		
⑬	Piston seal		
⑭	Tube gasket		

Disassembly/Replacement

⚠ Caution

1. Do not replace the bushings.

The bushings are press-fit. To replace them, they must be replaced together with the cover assembly.

2. To replace a seal, apply grease to the new seal before installing it.

If the cylinder is put into operation without applying grease to the seal, it could cause the seal to wear significantly, leading to premature air leakage.

3. Cylinders with ø50 or larger bore sizes cannot be disassembled.

When disassembling cylinders with bore sizes ø20 through ø40, grip the double flat part of either the rod cover with a vise and loosen the other side with a wrench or a monkey wrench, etc., and then remove the cover. When re-tightening, tighten approximately 2 degrees more than the original position.

(Cylinders with ø50 or larger bore sizes are tightened with a large tightening torque and cannot be disassembled. If disassembly is required, please contact SMC.)

Replacement Parts: Seal Kit

Bore size (mm)	Kit no.	Contents
20	CG1KWN20-PS	Set of left nos. ⑪, ⑫, ⑬, ⑭.
25	CG1KWN25-PS	
32	CG1KWN32-PS	
40	CG1KWN40-PS	

Note) Order with a part number for each type and bore size.

* The seal kit includes a grease pack (10 g).

Order with the following part number when only the grease pack is needed.

Grease pack part no.: GR-S-010 (10 g)

Air Cylinder/Direct Mount Type: Double Acting, Single Rod

Series CG1R

$\varnothing 20, \varnothing 25, \varnothing 32$
 $\varnothing 40, \varnothing 50, \varnothing 63$

Replacement
 Procedure is
 p.281

Construction

Standard, bottom mounting, with rubber bumper

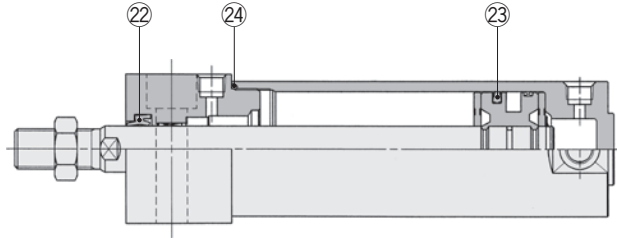

With air cushion

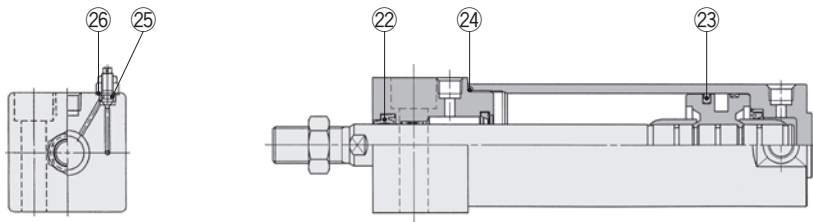

* The numbers are the same as the "Construction" of the Best Pneumatics No.2 Series CG1R.

Seal Kit List

No.	Description	Material	Note
22	Rod seal	NBR	
23	Piston seal		
24	Tube gasket		
25	Valve seal		
26	Valve retainer gasket		

Disassembly/Replacement

⚠ Caution

1. Do not replace the bushings.

The bushings are press-fit. To replace them, they must be replaced together with the cover assembly.

2. To replace a seal, apply grease to the new seal before installing it.

If the cylinder is put into operation without applying grease to the seal, it could cause the seal to wear significantly, leading to premature air leakage.

3. Cylinders with $\varnothing 50$ or larger bore sizes cannot be disassembled.

When disassembling cylinders with bore sizes $\varnothing 20$ through $\varnothing 40$, grip the double flat part of either the head cover or the rod cover with a vise and loosen the other side with a wrench or a monkey wrench, etc., and then remove the cover. When re-tightening, tighten approximately 2 degrees more than the original position.

(Cylinders with $\varnothing 50$ or larger bore sizes are tightened with a large tightening torque and cannot be disassembled. If disassembly is required, please contact SMC.)

Replacement Parts: Seal Kit

Bore size (mm)	Kit no.	Contents
With rubber bumper		
20	CG1N20-PS	Set of left nos. 22, 23, 24.
25	CG1N25-PS	
32	CG1N32-PS	
40	CG1N40-PS	
With air cushion		
20	CG1A20-PS	Set of left nos. 22, 23, 24, 25, 26.
25	CG1A25-PS	
32	CG1A32-PS	
40	CG1A40-PS	

Note) Order with a part number for each type and bore size.

* The seal kit includes a grease pack (10 g).

Order with the following part number when only the grease pack is needed.

Grease pack part no.: GR-S-010 (10 g)

Series CG1KR

ø20, ø25, ø32
ø40, ø50, ø63



Construction

Non-rotating rod, bottom mounting

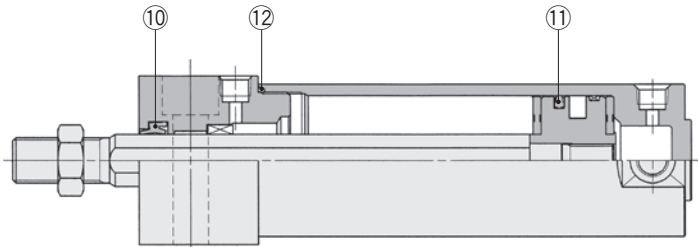

* The numbers are the same as the "Construction" of the Best Pneumatics No.2 Series CG1KR.

Seal Kit List

No.	Description	Material	Note
⑩	Rod seal	NBR	
⑪	Piston seal		
⑫	Tube gasket		

Disassembly/Replacement

⚠ Caution

1. Do not replace the bushings.

The bushings are press-fit. To replace them, they must be replaced together with the cover assembly.

2. To replace a seal, apply grease to the new seal before installing it.

If the cylinder is put into operation without applying grease to the seal, it could cause the seal to wear significantly, leading to premature air leakage.

3. Cylinders with ø50 or larger bore sizes cannot be disassembled.

When disassembling cylinders with bore sizes ø20 through ø40, grip the double flat part of either the head cover or the rod cover with a vise and loosen the other side with a wrench or a monkey wrench, etc., and then remove the cover. When re-tightening, tighten approximately 2 degrees more than the original position.

(Cylinders with ø50 or larger bore sizes are tightened with a large tightening torque and cannot be disassembled. If disassembly is required, please contact SMC.)

Replacement Parts: Seal Kit

Bore size (mm)	Kit no.	Contents
With rubber bumper		
20	CG1KN20-PS	Set of left nos. ⑩, ⑪, ⑫.
25	CG1KN25-PS	
32	CG1KN32-PS	
40	CG1KN40-PS	

Note) Order with a part number for each type and bore size.

* The seal kit includes a grease pack (10 g).

Order with the following part number when only the grease pack is needed.

Grease pack part no.: GR-S-010 (10 g)

Air Cylinder/With End Lock

Series CBG1

ø20, ø25, ø32, ø40
ø50, ø63, ø80, ø100

Replacement
Procedure is
P.281

Construction

Head end lock with rubber bumper

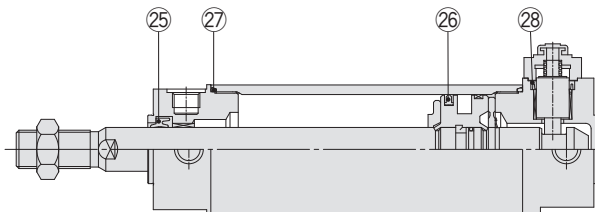

Head end lock with air cushion

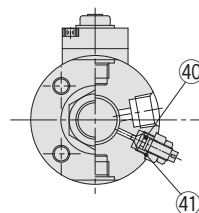
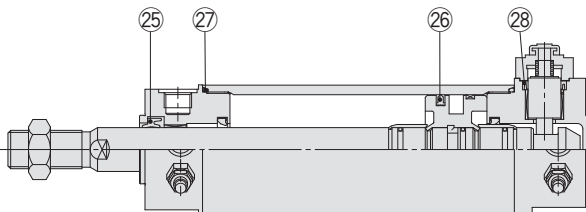

* The numbers are the same as the "Construction" of the Best Pneumatics No.2 Series CBG1.

Seal Kit List

No.	Description	Material	Note
25	Rod seal	NBR	
26	Piston seal		
27	Cylinder tube gasket		1 pc. at the time of tube cover use
28	Lock piston seal		2 pcs. with locking at both ends

Replacement Parts: Seal Kit

Series	Bore size (mm)	Kit no.	Contents
CBG1□N Rubber bumper type	20	CBG1N20-PS	Above no.
	25	CBG1N25-PS	25, 26, 27, 28.
	32	CBG1N32-PS	And a grease pack.
	40	CBG1N40-PS	

Locking at both ends

CBG1□N Rubber bumper type	20	CBG1N20-PS-W	Above no.
	25	CBG1N25-PS-W	25, 26, 27, 28.
	32	CBG1N32-PS-W	And a grease pack.
	40	CBG1N40-PS-W	

Note) Order with a part number for each type and bore size.

* The seal kit includes a grease pack (10 g).

Order with the following part number when only the grease pack is needed.

Grease pack part no.: GR-S-010 (10 g)

Seal Kit List

No.	Description	Material	Note
25	Rod seal	NBR	
26	Piston seal		
27	Cylinder tube gasket		1 pc. at the time of tube cover use
28	Lock piston seal		2 pcs. with locking at both ends
40	Valve seal		
41	Valve retainer gasket		

Replacement Parts: Seal Kit

Series	Bore size (mm)	Kit no.	Contents
CBG1□A Air cushion type	20	CBG1A20-PS	Above no.
	25	CBG1A25-PS	25, 26, 27, 28,
	32	CBG1A32-PS	40, 41. And a grease pack.
	40	CBG1A40-PS	

Locking at both ends

CBG1□A Air cushion type	20	CBG1A20-PS-W	Above no.
	25	CBG1A25-PS-W	25, 26, 27, 28,
	32	CBG1A32-PS-W	40, 41. And a grease pack.
	40	CBG1A40-PS-W	

Note) Order with a part number for each type and bore size.

* The seal kit includes a grease pack (10 g).

Order with the following part number when only the grease pack is needed.

Grease pack part no.: GR-S-010 (10 g)

Disassembly/Replacement

⚠ Caution

1. Do not replace the bushings.

The bushings are press-fit. To replace them, they must be replaced together with the cover assembly.

2. To replace a seal, apply grease to the new seal before installing it.

If the cylinder is put into operation without applying grease to the seal, it could cause the seal to wear significantly, leading to premature air leakage.

3. Cylinders with ø50 or larger bore sizes cannot be disassembled.

When disassembling cylinders with bore sizes ø20 through ø40, grip

the double flat part of either the head cover or the rod cover with a vise and loosen the other side with a wrench or a monkey wrench, etc., and then remove the cover. When re-tightening, tighten approximately 2 degrees more than the original position.

(Cylinders with ø50 or larger bore sizes are tightened with a large tightening torque and cannot be disassembled. If disassembly is required, please contact SMC.)

Disassembly in a locked state, may cause damage to the lock parts, it is recommended to work in the unlocked position.

Air Cylinder Short Type/Standard: Double Acting, Single Rod

Series CG3

ø20, ø25, ø32, ø40
ø50, ø63, ø80, ø100

Replacement
Procedure is
P.281

Construction

With rubber bumper

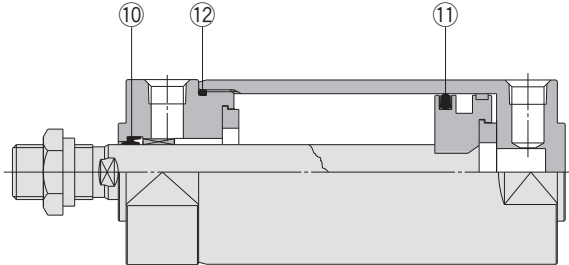

* The numbers are the same as the "Construction" of the Series CG3 catalog (CAT.ES20-213).

Seal Kit List

No.	Description	Material	Note
⑩	Rod seal	NBR	
⑪	Piston seal		
⑫	Tube gasket		

Disassembly/Replacement

Caution

1. Do not replace the bushings.

The bushings are press-fit. To replace them, they must be replaced together with the cover assembly.

2. To replace a seal, apply grease to the new seal before installing it.

If the cylinder is put into operation without applying grease to the seal, it could cause the seal to wear significantly, leading to premature air leakage.

3. Cylinders with ø50 or larger bore sizes cannot be disassembled.

When disassembling cylinders with bore sizes ø20 through ø40, grip the double flat part of either the head cover or the rod cover with a vise and loosen the other side with a wrench or a monkey wrench, etc., and then remove the cover. When re-tightening, tighten approximately 2 degrees more than the original position.

(Cylinders with ø50 or larger bore sizes are tightened with a large tightening torque and cannot be disassembled. If disassembly is required, please contact SMC.)

Replacement Parts: Seal Kit

Bore size (mm)	Kit no.	Contents
20	CG3N20-PS	Set of left nos. ⑩, ⑪, ⑫.
25	CG3N25-PS	
32	CG3N32-PS	
40	CG3N40-PS	

Note) Refer to the following for disassembly/replacement.

Order with a part number for each type and bore size.

* The seal kit includes a grease pack (10 g).

Order with the following part number when only the grease pack is needed.

Grease pack part no.: GR-S-010 (10 g)

Series MB

ø32, ø40, ø50, ø63
ø80, ø100, ø125

Replacement
Procedure is
P.284

Construction

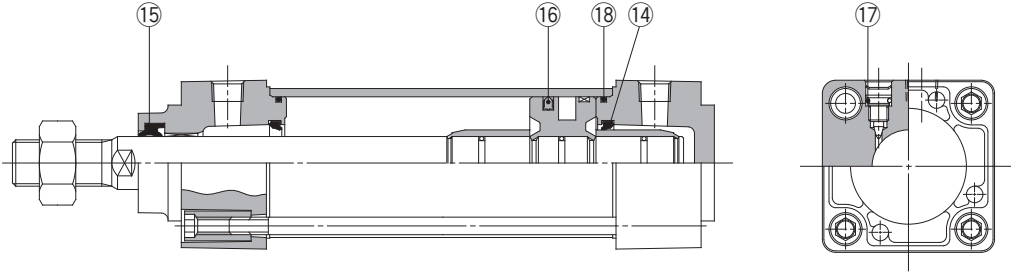

* The numbers are the same as the "Construction" of the Best Pneumatics No.2 Series MB.

Seal Kit List

No.	Description	Material	Note
14	Cushion seal	Urethane	17 is a non-replaceable part, so it is not included in the seal kit.
15	Rod seal	NBR	
16	Piston seal	NBR	
17	Cushion valve seal	NBR	
18	Cylinder tube gasket	NBR	

Replacement Parts: Seal Kit

Bore size (mm)	Kit no.	Contents
32	MB32-PS	Set of left nos. 14, 15, 16, 18.
40	MB40-PS	
50	MB50-PS	
63	MB63-PS	
80	MB80-PS	
100	MB100-PS	
125	MB125-PS	

* Seal kits consist of items 14, 15, 16 and 18, and can be ordered by using the seal kit number corresponding to each bore size.

* Trunnion type should not be disassembled.

* Seal kit includes a grease pack (ø32 to 50: 10 g, ø63, 80: 20 g, ø100, 125: 30 g).

Order with the following part number when only the grease pack is needed.

Grease pack part no.: GR-S-010 (10 g), GR-S-020 (20 g)

Actuators

Modular F.R.L.
Pressure Control Equipment

Air Preparation
Equipment

Industrial Filters

Replacement
Procedure

Actuators

Modular F.R.L.
Pressure Control Equipment

Industrial Filters

Series MBW

ø32, ø40, ø50, ø63
ø80, ø100, ø125



Construction

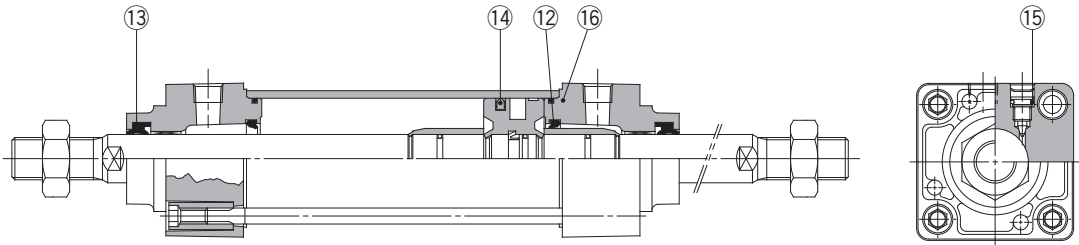

* The numbers are the same as the "Construction" of the Best Pneumatics No.2 Series MBW.

Seal Kit List

No.	Description	Material	Note
12	Cushion seal	Urethane	15 is a non-replaceable part, so it is not included in the seal kit.
13	Rod seal	NBR	
14	Piston seal	NBR	
15	Cushion valve seal	NBR	
16	Cylinder tube gasket	NBR	

Replacement Parts: Seal Kit

Bore size (mm)	Kit no.	Contents
32	MBW32-PS	Set of left nos. 12, 13, 14, 16.
40	MBW40-PS	
50	MBW50-PS	
63	MBW63-PS	
80	MBW80-PS	
100	MBW100-PS	
125	MBW125-PS	

* Seal kits consist of items 12, 13, 14 and 16, and can be ordered by using the seal kit number corresponding to each bore size.

* Trunnion type should not be disassembled.

* Seal kit includes a grease pack (ø32 to 50: 10 g, ø63, 80: 20 g, ø100, 125: 30 g).

Order with the following part number when only the grease pack is needed.

Grease pack part no.: GR-S-010 (10 g), GR-S-020 (20 g)

Series MBK

ø32, ø40, ø50
ø63, ø80, ø100



Construction

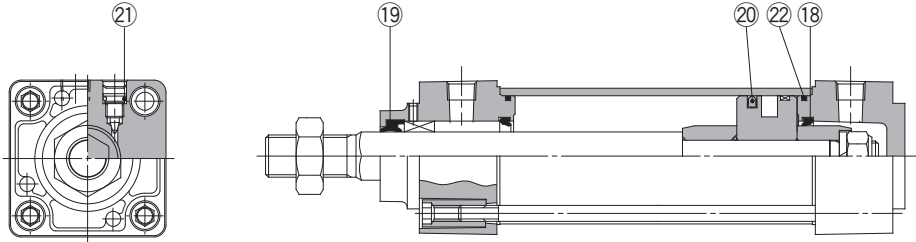

* The numbers are the same as the "Construction" of the Best Pneumatics No.2 Series MBK.

Seal Kit List

No.	Description	Material	Note
18	Cushion seal	Urethane	21 is a non-replaceable part, so it is not included in the seal kit.
19	Rod seal	NBR	
20	Piston seal	NBR	
21	Cushion valve seal	NBR	
22	Cylinder tube gasket	NBR	

Replacement Parts: Seal Kit

Bore size (mm)	Kit no.	Contents
32	MBK32-PS	Set of left nos. 18, 19, 20, 22.
40	MBK40-PS	
50	MBK50-PS	
63	MBK63-PS	
80	MBK80-PS	
100	MBK100-PS	

* Seal kits consist of items 18, 19, 20 and 22, and can be ordered by using the seal kit number corresponding to each bore size.

* Seal kit includes a grease pack (ø32 to 50: 10 g, ø63, 80: 20 g, ø100, 125: 30 g).

Order with the following part number when only the grease pack is needed.

Grease pack part no.: GR-S-010 (10 g), GR-S-020 (20 g)

* Model without air cushion is designed to include rubber bumpers.

Actuators

Modular F.R.L.
Pressure Control Equipment

Air Preparation
Equipment

Industrial Filters

Replacement
Procedure

Actuators

Modular F.R.L.
Pressure Control Equipment

Industrial Filters

Series MB□Q

ø32, ø40, ø50
ø63, ø80, ø100



Construction

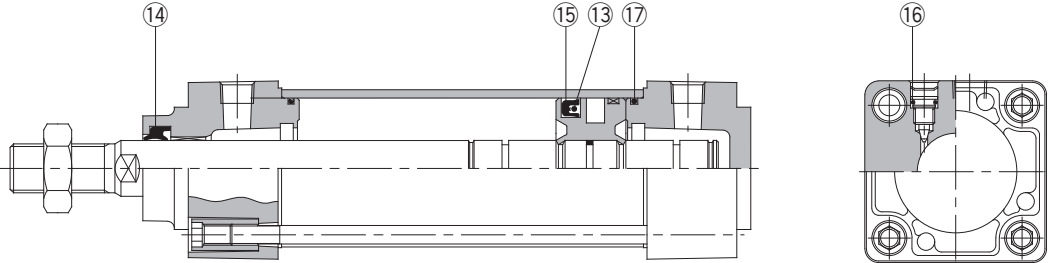

* The numbers are the same as the "Construction" of the Best Pneumatics No.2 Series MB□Q.

Seal Kit List

No.	Description	Material	Note
⑬	Back-up O-ring	NBR	16 is a non-replaceable part, so it is not included in the seal kit.
⑭	Rod seal		
⑮	Piston seal		
⑯	Cushion valve seal		
⑰	Cylinder tube gasket		

Replacement Parts: Seal Kit

Bore size (mm)	Kit no.	Contents
32	MBQ32-PS	Set of left nos. ⑬, ⑭, ⑮, ⑰.
40	MBQ40-PS	
50	MBQ50-PS	
63	MBQ63-PS	
80	MBQ80-PS	
100	MBQ100-PS	

* Seal kits consist of items ⑬, ⑭, ⑮ and ⑰, and can be ordered by using the seal kit number corresponding to each bore size.

* Trunnion type should not be disassembled.

* Since the seal kit does not include a grease pack, order it separately.

Grease pack part no.: GR-L-005 (5 g), GR-L-010 (10 g), GR-L-150 (150 g)

Series MBB

ø32, ø40, ø50
ø63, ø80, ø100

Replacement
Procedure is
p.284

Construction

Locking at head end

Manual release non-locking type: N

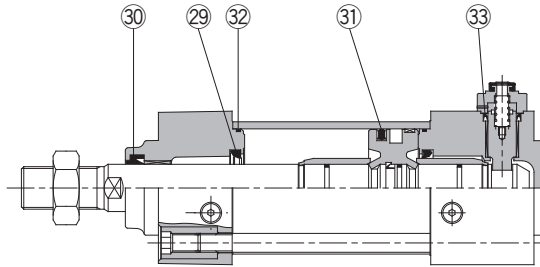

* The numbers are the same as the "Construction" of the Best Pneumatics No.2 Series MBB.

Seal Kit List

No.	Description	Material	Note
29	Cushion seal	Urethane	
30	Rod seal	NBR	
31	Piston seal	NBR	
32	Cylinder tube gasket	NBR	
33	Lock piston seal	NBR	

Replacement Parts: Seal Kit

Bore size (mm)	Kit no.	Contents
Locking at head or rod end		
32	MBB32-PS	Set of left nos. 29, 30, 31, 32 and 33.
40	MBB40-PS	
50	MBB50-PS	
63	MBB63-PS	
80	MBB80-PS	
100	MBB100-PS	
Locking at both ends		
32	MBB32-PS-W	Set of left nos. 29, 30, 31, 32 and 33.
40	MBB40-PS-W	
50	MBB50-PS-W	
63	MBB63-PS-W	
80	MBB80-PS-W	
100	MBB100-PS-W	

- * Seal kits consist of items 29 to 33, and can be ordered by using the seal kit number corresponding to each bore size.
- * Trunnion type should not be disassembled.
- * Seal kit includes a grease pack (ø32 to 50: 10 g, ø63, 80: 20 g, ø100: 30 g).
Order with the following part number when only the grease pack is needed.
Grease pack part no.: GR-S-010 (10 g), GR-S-020 (20 g)

Actuators

Modular F.R.L.
Pressure Control Equipment

Air Preparation
Equipment

Industrial Filters

Replacement
Procedure

Actuators

Modular F.R.L.
Pressure Control Equipment

Industrial Filters

Series MB1

ø32, ø40, ø50, ø63
ø80, ø100, ø125

Replacement
Procedure is
P.284

Construction

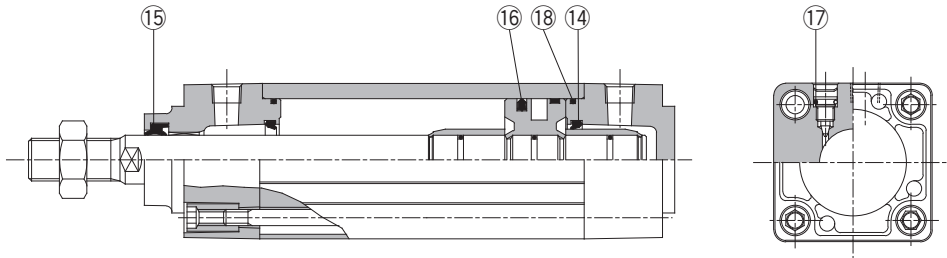

* The numbers are the same as the "Construction" of the Best Pneumatics No.2 Series MB1.

Seal Kit List

No.	Description	Material	Note
14	Cushion seal	Urethane	17 is a non-replaceable part, so it is not included in the seal kit.
15	Rod seal	NBR	
16	Piston seal	NBR	
17	Cushion valve seal	NBR	
18	Cylinder tube gasket	NBR	

Replacement Parts: Seal Kit

Bore size (mm)	Kit no.	Contents
32	MB32-PS	Set of left nos. 14, 15, 16, 18.
40	MB40-PS	
50	MB50-PS	
63	MB63-PS	
80	MB80-PS	
100	MB100-PS	

* Seal kit includes 14 to 16, 18. Order the seal kit, based on each bore size.

* Seal kit includes a grease pack (ø32 to 50 : 10 g, ø63, 80 : 20 g, ø100 : 30g).

Order with the following part number when only the grease pack is needed.

Grease pack part no. : GR-S-010 (10g), GR-S-020 (20g)

Series MB1W

ø32, ø40, ø50
ø63, ø80, ø100
ø125

Replacement
Procedure is
P.284

Construction

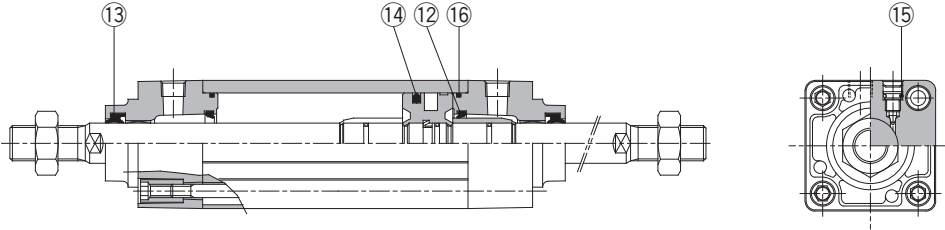

* The numbers are the same as the "Construction" of the Best Pneumatics No.2 Series MB1W.

Seal Kit List

No.	Description	Material	Note
12	Cushion seal	Urethane	15 is a non-replaceable part, so it is not included in the seal kit.
13	Rod seal	NBR	
14	Piston seal	NBR	
15	Cushion valve seal	NBR	
16	Cylinder tube gasket	NBR	

Replacement Parts: Seal Kit

Bore size (mm)	Kit no.	Contents
32	MBW32-PS	Set of left nos. 12, 13, 14, 16.
40	MBW40-PS	
50	MBW50-PS	
63	MBW63-PS	
80	MBW80-PS	
100	MBW100-PS	

* Seal kit includes 12 to 14, 16. Order the seal kit, based on each bore size.

* Seal kit includes a grease pack (ø32 to 50: 10 g, ø63, 80: 20 g, ø100: 30 g).
Order with the following part number when only the grease pack is needed.

Grease pack part no.: GR-S-010 (10 g), GR-S-020 (20 g)

Actuators

Modular F.R.L.
Pressure Control Equipment

Air Preparation
Equipment

Industrial Filters

Replacement
Procedure

Actuators

Modular F.R.L.
Pressure Control Equipment

Industrial Filters

Series MB1K

ø32, ø40, ø50
ø63, ø80, ø100

Replacement
Procedure is
P.284

Construction

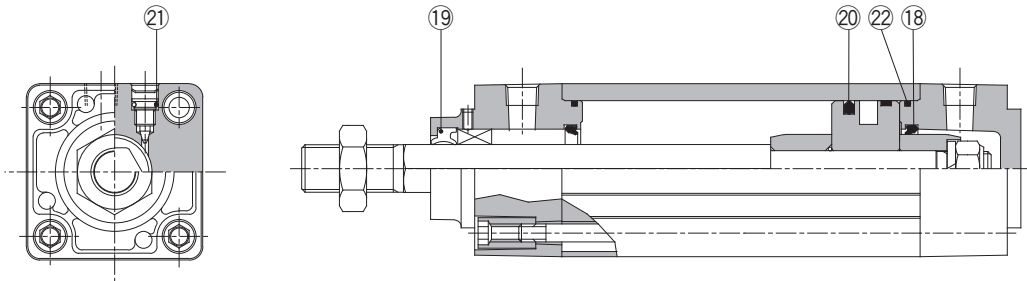

* The numbers are the same as the "Construction" of the Best Pneumatics No.2 Series MB1K.

Seal Kit List

No.	Description	Material	Note
18	Cushion seal	Urethane	21 is a non-replaceable part, so it is not included in the seal kit.
19	Rod seal	NBR	
20	Piston seal	NBR	
21	Cushion valve seal	NBR	
22	Cylinder tube gasket	NBR	

Replacement Parts: Seal Kit

Bore size (mm)	Kit no.	Contents
32	MBK32-PS	Set of left nos. 18, 19, 20, 22.
40	MBK40-PS	
50	MBK50-PS	
63	MBK63-PS	
80	MBK80-PS	
100	MBK100-PS	

* Seal kit includes 18 to 20, 22. Order the seal kit, based on each bore size.

* Seal kit includes a grease pack (ø32 to 50 : 10 g, ø63, 80 : 20 g, ø100 : 30 g).

Order with the following part number when only the grease pack is needed.

Grease pack part no.: GR-S-010 (10 g), GR-S-020 (20 g)

* In the case of w/o air cushion, it comes with rubber bumper.

Series CA2

ø40, ø50, ø63, ø80, ø100

Replacement Procedure is P.284

Construction

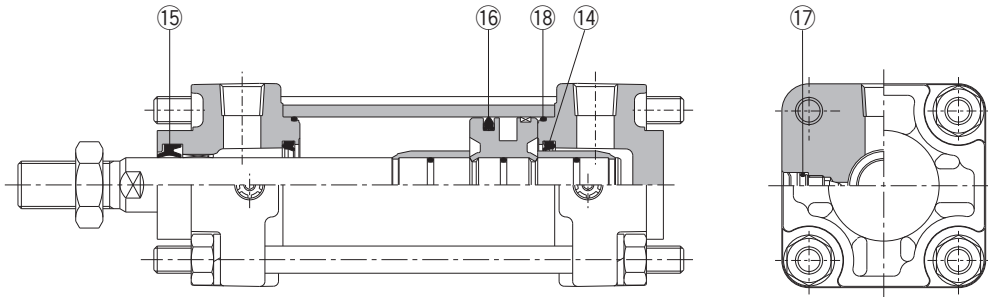

* The numbers are the same as the "Construction" of the Best Pneumatics No.2 Series CA2.

Seal Kit List

No.	Description	Material	Note
14	Cushion seal	Urethane	17 is a non-replaceable part, so it is not included in the seal kit.
15	Rod seal	NBR	
16	Piston seal	NBR	
17	Cushion valve seal	NBR	
18	Cylinder tube gasket	NBR	

Replacement Parts: Seal Kit

Bore size (mm)	Kit no.	Contents
40	MB40-PS	Set of left nos. 14, 15, 16, 18.
50	MB50-PS	
63	MB63-PS	
80	MB80-PS	
100	MB100-PS	

* Seal kit includes 14, 15, 16 and 18. Order the seal kit based on each bore size.

* Do not disassemble the trunnion style.

* Seal kit includes a grease pack (ø40, 50: 10 g, ø63, 80: 20 g, ø100: 30 g).

Order with the following part number when only the grease pack is needed.

Grease pack part no.: GR-S-010 (10 g), GR-S-020 (20 g)

Actuators

Modular F.R.L.
Pressure Control Equipment

Air Preparation
Equipment

Industrial Filters

Replacement
Procedure

Actuators

Modular F.R.L.
Pressure Control Equipment

Industrial Filters

Series CA2W

ø40, ø50, ø63
ø80, ø100

Replacement
Procedure is
P.284

Construction

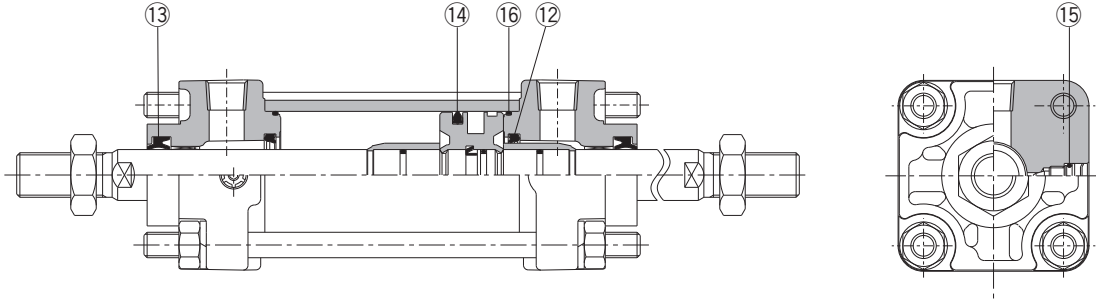

* The numbers are the same as the "Construction" of the Best Pneumatics No.2 Series CA2W.

Seal Kit List

No.	Description	Material	Note
12	Cushion seal	Urethane	
13	Rod seal	NBR	
14	Piston seal	NBR	
15	Cushion valve seal	NBR	O-ring
16	Cylinder tube gasket	NBR	

15 is a non-replaceable part, so it is not included in the seal kit.

Replacement Parts: Seal Kit

Bore size (mm)	Kit no.	Contents
40	MBW40-PS	Set of left nos. 12, 13, 14, 16.
50	MBW50-PS	
63	MBW63-PS	
80	MBW80-PS	
100	MBW100-PS	

* Do not disassemble the trunnion style.

* Seal kit includes 12, 13, 14 and 16. Order the seal kit based on each bore size.

* Seal kit includes a grease pack (ø40, 50: 10 g, ø63, 80: 20 g, ø100: 30 g).

Order with the following part number when only the grease pack is needed.

Grease pack part no.: GR-S-010 (10 g), GR-S-020 (20 g)

Series CA2K

ø40, ø50, ø63

Replacement Procedure is p.284

Construction

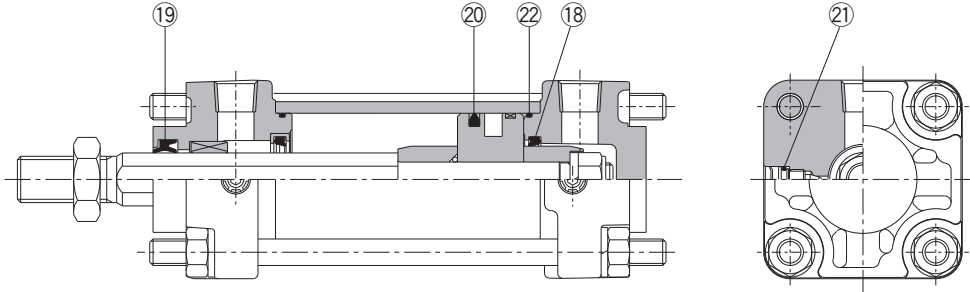

* The numbers are the same as the "Construction" of the Best Pneumatics No.2 Series CA2K.

Seal Kit List

No.	Description	Material	Note
18	Cushion seal	Urethane	21 is a non-replaceable part, so it is not included in the seal kit.
19	Rod seal	NBR	
20	Piston seal	NBR	
21	Cushion valve seal	NBR	
22	Cylinder tube gasket	NBR	

Disassembly/Replacement

1. Please consult with SMC when the rod seal is to be replaced.

When the rod seal is to be replaced, make sure that the seal's width across flats matches that of the non-rotating guide. A rod seal may allow air leakage depending on the position where it is installed. Therefore, please consult with SMC when a rod seal is to be replaced.

2. Do not replace the non-rotating guide.

Since the non-rotating guide is press fitted, the entire cover assembly needs to be replaced instead of a single part.

Replacement Parts: Seal Kit

Bore size (mm)	Kit no.	Contents
40	CA2K40-PS	Set of left nos. 18, 19, 20, 22.
50	CA2K50-PS	
63	CA2K63-PS	

* Seal kit includes 18, 19, 20 and 22. Order the seal kit based on each bore size.

* Do not disassemble the trunnion style.

* Seal kit includes a grease pack (ø40, 50: 10 g, over ø63: 20 g). Order with the following part number when only the grease pack is needed.

Grease pack part no.: GR-S-010 (10 g), GR-S-020 (20 g)

Actuators

Modular F.R.L.
Pressure Control Equipment

Air Preparation
Equipment

Industrial Filters

Replacement
Procedure

Actuators

Modular F.R.L.
Pressure Control Equipment

Industrial Filters

Air Cylinder/Non-rotating Rod Type: Double Acting, Double Rod

Series CA2KW

ø40, ø50
ø63

Replacement
Procedure is
p.284

Construction

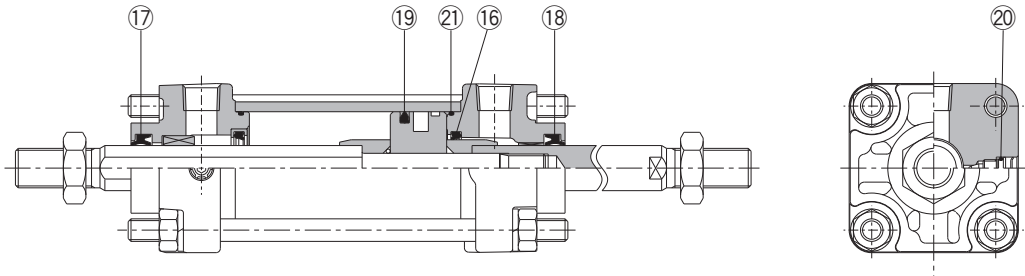

* The numbers are the same as the "Construction" of the Best Pneumatics No.2 Series CA2KW.

Seal Kit List

No.	Description	Material	Note
16	Cushion seal	Urethane	20 is a non-replaceable part, so it is not included in the seal kit.
17	Rod seal A	NBR	
18	Rod seal B	NBR	
19	Piston seal	NBR	
20	Cushion valve seal	NBR	
21	Cylinder tube gasket	NBR	

Disassembly/Replacement

1. Please consult with SMC when the rod seal is to be replaced.

When the rod seal is to be replaced, make sure that the seal's width across flats matches that of the non-rotating guide.

A rod seal may allow air leakage depending on the position where it is installed. Therefore, please consult with SMC when a rod seal is to be replaced.

2. Do not replace the non-rotating guide.

Since the non-rotating guide is press fitted, the entire cover assembly needs to be replaced instead of a single part.

Replacement Parts: Seal Kit

Bore size (mm)	Kit no.	Contents
40	CA2KW40-PS	Set of left nos. 16, 17, 18, 19, 21.
50	CA2KW50-PS	
63	CA2KW63-PS	

* Seal kit includes 16, 17, 18, 19, and 21. Order the seal kit based on each bore size.

* Do not disassemble the trunnion style.

* Seal kit includes a grease pack (ø40, 50: 10 g, ø63, 80: 20 g, ø100: 30 g).

Order with the following part number when only the grease pack is needed.

Grease pack part no.: GR-S-010 (10 g), GR-S-020 (20 g)

Series CBA2

ø40, ø50, ø63
ø80, ø100

Replacement
Procedure is
P.284

Construction

Head side end lock

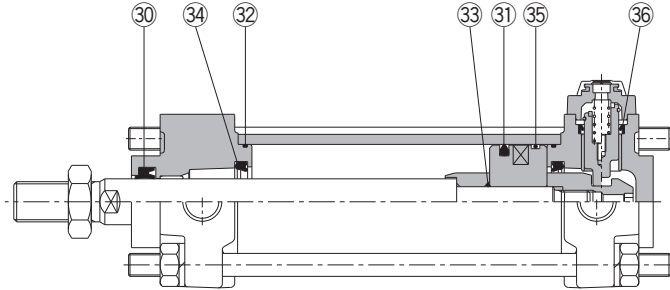

Manual release non-lock type: Suffix N

* The numbers are the same as the "Construction" of the Best Pneumatics No.2 Series CBA2.

Seal Kit List

No.	Description	Material	Note
30	Rod seal	NBR	33 and 35 are non-replaceable parts, so they are not included in the seal kit.
31	Piston seal	NBR	
32	Cylinder tube gasket	NBR	
33	Piston gasket	NBR	
34	Cushion seal	NBR	
35	Wear ring	Resin	
36	Lock piston seal	NBR	

Replacement Parts: Seal Kit

Bore size (mm)	Kit no.	Contents
Single end lock		
40	MBB40-PS	Set of left nos. 30, 31, 32, 34, 36.
50	MBB50-PS	
63	MBB63-PS	
80	MBB80-PS	
100	MBB100-PS	
Double end lock		
40	MBB40-PS-W	Set of left nos. 30, 31, 32, 34, 36.
50	MBB50-PS-W	
63	MBB63-PS-W	
80	MBB80-PS-W	
100	MBB100-PS-W	

* Seal kit includes 30, 31, 32, 34 and 36. Order the seal kit based on each bore size.

* Do not disassemble the trunnion style.

* Seal kit includes a grease pack (ø40, 50: 10 g, ø63, 80: 20 g, ø100: 30 g).

Order with the following part number when only the grease pack is needed.

Grease pack part no.: GR-S-010 (10 g), GR-S-020 (20 g)

Series CA2 H

ø40, ø50, ø63
ø80, ø100

Construction

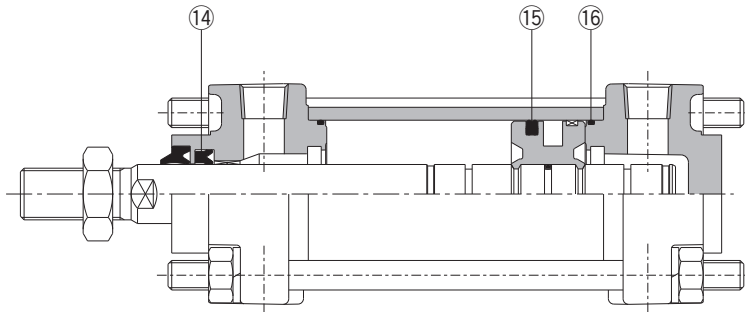

* The numbers are the same as the "Construction" of the Best Pneumatics No.2 Series CA2□H.

Seal Kit List

No.	Description	Material	Note
14	Rod seal	NBR	
15	Piston seal		
16	Cylinder tube gasket		

Replacement Parts: Seal Kit

Bore size (mm)	Kit no.	Contents
Air-hydro type		
40	CA2H40A-PS	Set of left nos. (14, 15, 16).
50	CA2H50A-PS	
63	CA2H63A-PS	
80	CA2H80A-PS	
100	CA2H100A-PS	

* Do not disassemble the trunnion style.

* Seal kit includes 14, 15 and 16. Order the seal kit based on each bore size.

* Seal kit includes a grease pack (ø40, 50: 10 g, ø63: 20 g). Order with the following part number when only the grease pack is needed.

Grease pack part no.: GR-S-010 (10 g), GR-S-020 (20 g)

Series CA2W□H

∅40, ∅50, ∅63
∅80, ∅100

Construction

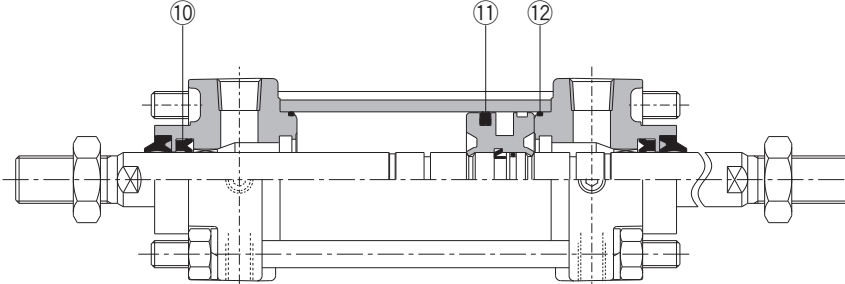

* The numbers are the same as the "Construction" of the Best Pneumatics No.2 Series CA2W□H.

Seal Kit List

No.	Description	Material	Note
⑩	Rod seal	NBR	
⑪	Piston seal		
⑫	Cylinder tube gasket		

Replacement Parts: Seal Kit

Bore size (mm)	Kit no.	Contents
Air-hydro type		
40	CA2WH40A-PS	Set of left nos. ⑩, ⑪, ⑫.
50	CA2WH50A-PS	
63	CA2WH63A-PS	
80	CA2WH80A-PS	
100	CA2WH100A-PS	

- * Do not disassemble the trunnion style.
- * Seal kit includes ⑩, ⑪ and ⑫. Order the seal kit based on each bore size.
- * Seal kit includes a grease pack (∅40, 50: 10 g, ∅63 or more: 20 g). Order with the following part number when only the grease pack is needed.

Grease pack part no.: GR-S-010 (10 g), GR-S-020 (20 g)

Actuators

Modular F.R.L.
Pressure Control Equipment

Air Preparation
Equipment

Industrial Filters

Replacement
Procedure

Actuators

Modular F.R.L.
Pressure Control Equipment

Industrial Filters

Series CS1

Lube, Non-lube Type:
 ø125, ø140, ø160, ø180
 ø200, ø250, ø300
Air-hydro Type:
 ø125, ø140, ø160

Replacement
 Procedure is
 P.287

Construction

Lube

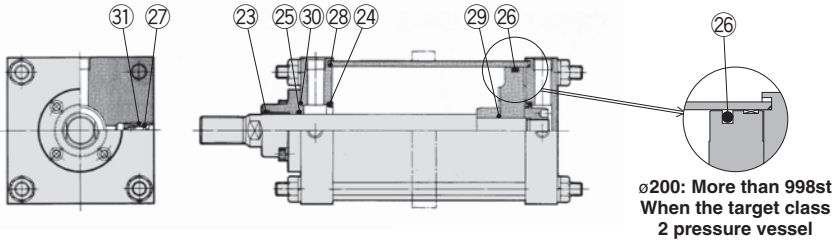

Non-lube

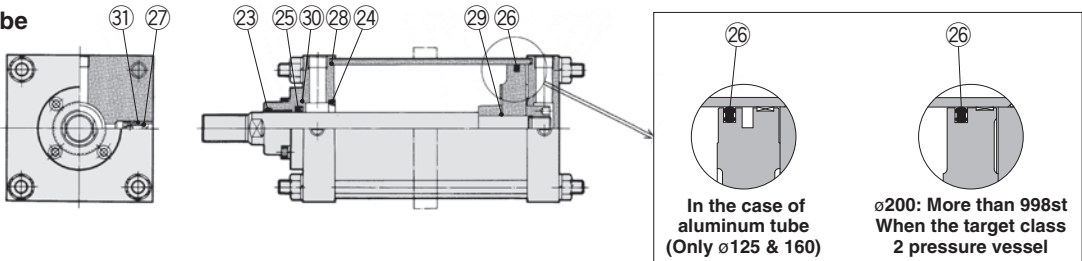

Air-hydro

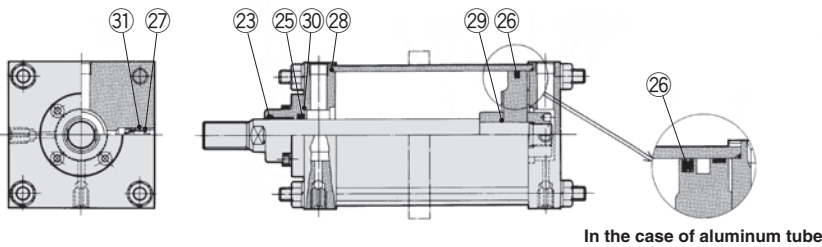

* The numbers are the same as the "Construction" of the Best Pneumatics No.2 Series CS1.

Seal Kit List

No.	Description	Material	Note
23	Wiper ring	NBR	24, 29 and 31 are non-replaceable parts, so they are not included in the seal kit.
24	Cushion seal		
25	Rod seal		
26	Piston seal		
27	Valve seal		
28	Tube gasket		
29	Piston gasket		
30	Retaining plate gasket		
31	Guide gasket		

Replacement Parts: Seal Kit

Bore size (mm)	Kit no.	Contents
Standard (lube)		
125	CS1-125A-PS	Component part numbers: 23, 25, 26, 27, 28, 30.
140	CS1-140A-PS	
160	CS1-160A-PS	
180	CS1-180A-PS	
200	CS1-200A-PS	
250	CS1-250A-PS	
300	CS1-300A-PS	
Standard (non-lube)		
125	CS1N125A-PS	Component part numbers: 23, 25, 26, 27, 28, 30.
140	CS1N140A-PS	
160	CS1N160A-PS	
180	CS1N180A-PS	
200	CS1N200A-PS	
250	CS1N250A-PS	
300	CS1N300A-PS	

* Seal kit includes a grease pack (ø125 to 160: 40 g, ø180 and 200: 50 g, ø250 and 300: 60 g).

Order with the following part number when only the grease pack is needed.

Grease pack part no.: GR-S-010 (10 g), GR-S-020 (20 g)

Air-hydro type

Bore size (mm)	Kit no.	Contents
125	CS1H125A-PS	Component part numbers: 23, 25, 26, 27, 28, 30.
140	CS1H140A-PS	
160	CS1H160A-PS	

Series CDS1

ø125, ø140, ø160
ø180, ø200

Replacement
Procedure is
P.287

Construction

Lube 1, 2

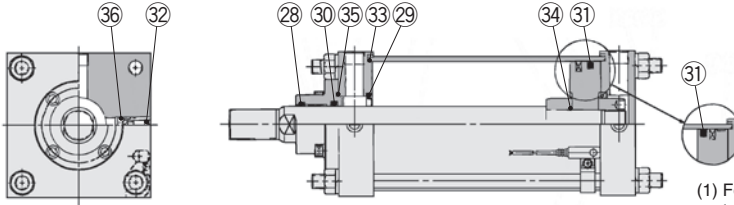

- (1) Foot style: Rod side flange style
In the case of ø125, ø140
1001 to 1400 st
In the case of ø160
1201 to 1400 st
(2) In the case of ø180, ø200
(1), (2): Non-lube type is used.

Non-lube

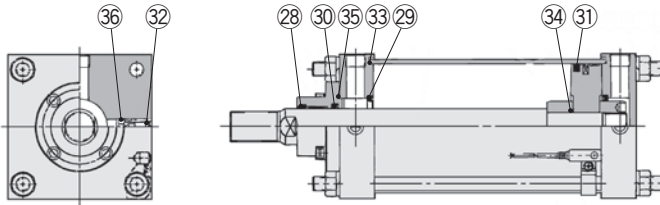

Air-hydro: ø125, ø140, ø160 only

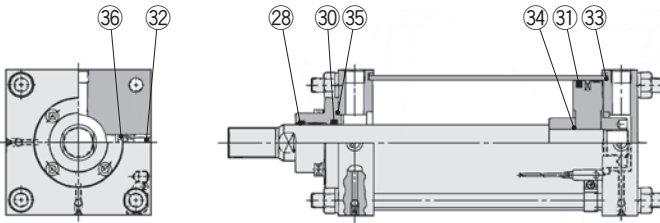

* The numbers are the same as the "Construction" of the Best Pneumatics No.2 Series CS1.

Seal Kit List

No.	Description	Material	Note
28	Wiper ring	NBR	29, 34 and 36 are non-replaceable parts, so they are not included in the seal kit.
29	Cushion seal		
30	Rod seal		
31	Piston seal		
32	Valve seal		
33	Tube gasket		
34	Piston gasket		
35	Retaining plate gasket		
36	Guide gasket		

Replacement Parts: Seal Kit

Bore size (mm)	Kit no.	Contents
Lube (1)		
125	CS1-125A-PS	Component part numbers: 28, 30, 31, 32, 33, 35.
140	CS1-140A-PS	
160	CS1-160A-PS	
180	CDS1-180A-PS	
200	CDS1-200A-PS	
Non-lube		
125	CS1N125A-PS	Component part numbers: 28, 30, 31, 32, 33, 35.
140	CS1N140A-PS	
160	CS1N160A-PS	
180	CS1N180A-PS	
200	CS1N200A-PS	
Lube (2) ^(note)		
125	CDS1L125A-PS	Component part numbers: 28, 30, 31, 32, 33, 35.
140	CDS1L140A-PS	
160	CDS1L160A-PS	

* Seal kit includes a grease pack (ø125 to 160: 40 g, ø180 and 200: 50 g).
Order with the following part number when only the grease pack is needed.

Grease pack part no.: GR-S-010 (10 g), GR-S-020 (20 g)

(note) Foot style, Rod side flange style: ø125, ø140: 1001 to 1400 stroke, ø160: 1201 to 1400 stroke.

Air-hydro

Bore size (mm)	Kit no.	Contents
125	CS1H125A-PS	Component part numbers: 28, 30, 31, 32, 33, 35.
140	CS1H140A-PS	
160	CS1H160A-PS	

Air Cylinder/Double Rod Type

Series CS1W

Lube, Non-lube Type:
 $\phi 125$, $\phi 140$, $\phi 160$, $\phi 180$
 $\phi 200$, $\phi 250$, $\phi 300$
Air-hydro Type:
 $\phi 125$, $\phi 140$, $\phi 160$



Construction

Lube, non-lube with auto switch

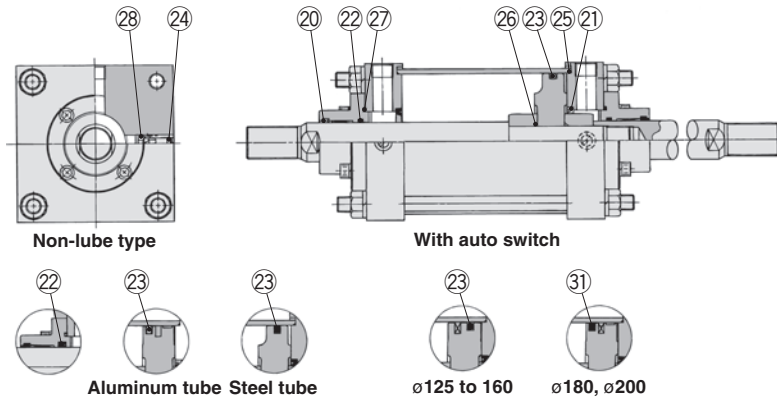

Air-hydro

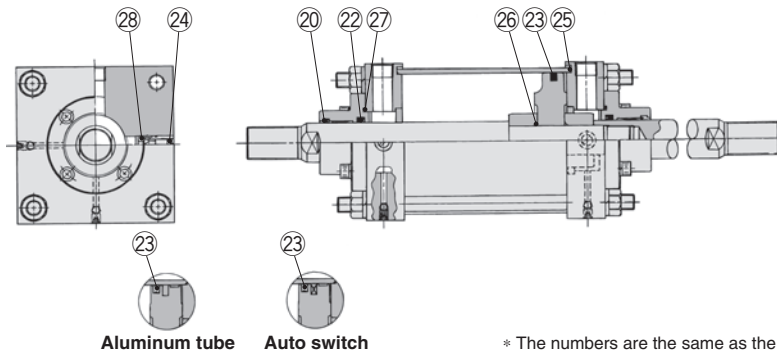

* The numbers are the same as the "Construction" of the Best Pneumatics No.2 Series CS1.

Seal Kit List

No.	Description	Material	Note
20	Wiper ring	NBR	21, 26 and 28 are non-replaceable parts, so they are not included in the seal kit.
21	Cushion seal		
22	Rod seal		
23	Piston seal		
31	Valve seal		
24	Tube gasket		
25	Piston gasket		
27	Retaining plate gasket		
28	Guide gasket		

Replacement Parts: Seal Kit

Bore size (mm)	Kit no.	Contents
Lube		
125	CS1W-125A-PS	Component part numbers: 20, 22, 23, 24, 25, 27.
140	CS1W-140A-PS	
160	CS1W-160A-PS	
180	CS1W-180A-PS	
200	CS1W-200A-PS	
250	CS1W-250A-PS	
300	CS1W-300A-PS	

* Seal kit includes a grease pack ($\phi 125$ to 160 : 40 g, $\phi 180$ and 200 : 50 g, $\phi 250$ and 300 : 60 g). Order with the following part number when only the grease pack is needed.

Grease pack part no.: GR-S-010 (10 g), GR-S-020 (20 g)

Replacement Parts: Seal Kit

Bore size (mm)	Kit no.	Contents
Non-lube with auto switch		
125	CS1WN125A-PS	Component part numbers: 20, 22, 23, 24, 25, 27.
140	CS1WN140A-PS	
160	CS1WN160A-PS	
180	CS1WN180A-PS	
200	CS1WN200A-PS	
250 ^{note)}	CS1WN250A-PS	
300 ^{note)}	CS1WN300A-PS	
Lube with auto switch		
125	CS1W125A-PS	Component part numbers: 20, 22, 24, 25, 27, 31.
140	CS1W140A-PS	
160	CS1W160A-PS	
180	CDS1W180A-PS	
200	CDS1W200A-PS	

note) It is not available with auto switch.

* Seal kit includes a grease pack ($\phi 125$ to 160 : 40 g, $\phi 180$ and 200 : 50 g, $\phi 250$ and 300 : 60 g). Order with the following part number when only the grease pack is needed.

Grease pack part no.: GR-S-010 (10 g), GR-S-020 (20 g)

Air-hydro

Bore size (mm)	Kit no.	Contents
125	CS1WH125A-PS	Component part numbers: 20, 22, 23, 24, 25, 27.
140	CS1WH140A-PS	
160	CS1WH160A-PS	

Series CS1□Q

ø125, ø140
ø160



Construction

Non-lube

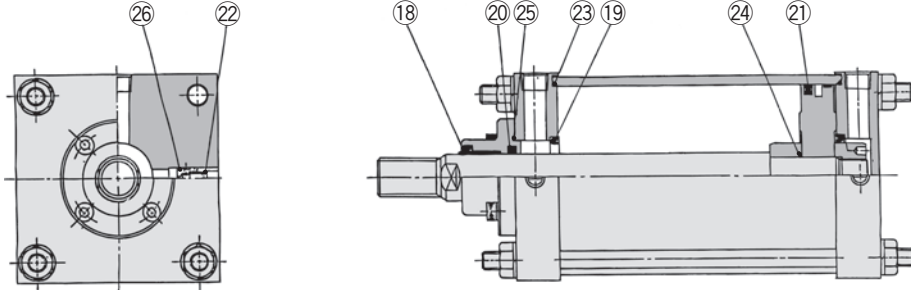

* The numbers are the same as the "Construction" of the Best Pneumatics No.2 Series CS1.

Seal Kit List

No.	Description	Material	Note
18	Wiper ring	NBR	19, 24 and 26 are non-replaceable parts, so they are not included in the seal kit.
19	Cushion seal *		
20	Rod seal		
21	Piston seal		
22	Valve seal		
23	Tube gasket		
24	Piston gasket		
25	Retaining plate gasket		
26	Guide gasket		

* It is used only in the case of w/ cushion type.

Replacement Parts/Seal Kit

Bore size (mm)	Kit no.	Contents
125	CS1Q125A-PS	Component part numbers: 18, 20, 21, 22, 23, 25.
140	CS1Q140A-PS	
160	CS1Q160A-PS	

* Since the seal kit does not include a grease pack, please arrange with the part numbers listed below only the grease pack separately. In that case, the amount of grease, please refer to the standard type.
Grease pack part no.: GR-L-020 (20 g)

Actuators

Modular F.R.L.
Pressure Control Equipment

Air Preparation
Equipment

Industrial Filters

Replacement
Procedure

Actuators

Modular F.R.L.
Pressure Control Equipment

Industrial Filters

Series CS2

ø125, ø140, ø160



Construction

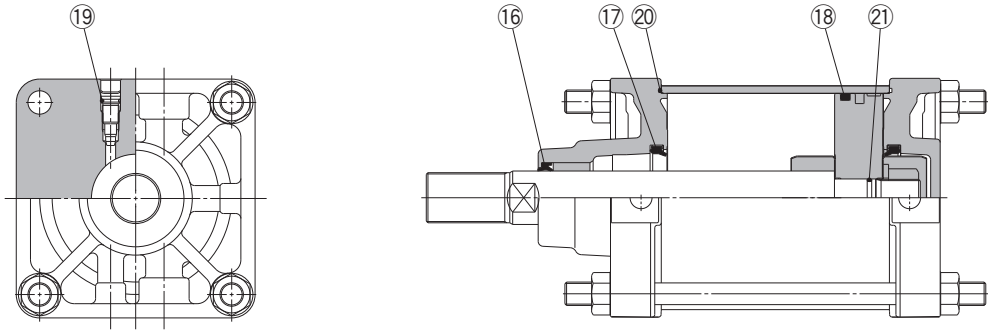

* The numbers are the same as the "Construction" of the CS2 series catalog (CAT.ES20-196).

Component Parts: Seal Kit List

No.	Description	Material	Note
16	Rod seal	NBR	19 and 21 are non-replaceable parts, so they are not included in the seal kit.
17	Cushion seal	Urethane	
18	Piston seal	NBR	
19	Valve seal	NBR	
20	Tube gasket	NBR	
21	Piston gasket	NBR	

Replacement Parts: Seal Kit

Bore size (mm)	Kit no.	Contents
125	CS2-125A-PS	Component part numbers: 16, 17, 18, 20.
140	CS2-140A-PS	
160	CS2-160A-PS	

* Seal kit includes a grease pack (40 g).

Order with the following part number when only the grease pack is needed.

Grease pack part no.: GR-S-010 (10 g), GR-S-020 (20 g)

Series CS2W

ø125, ø140, ø160



Construction

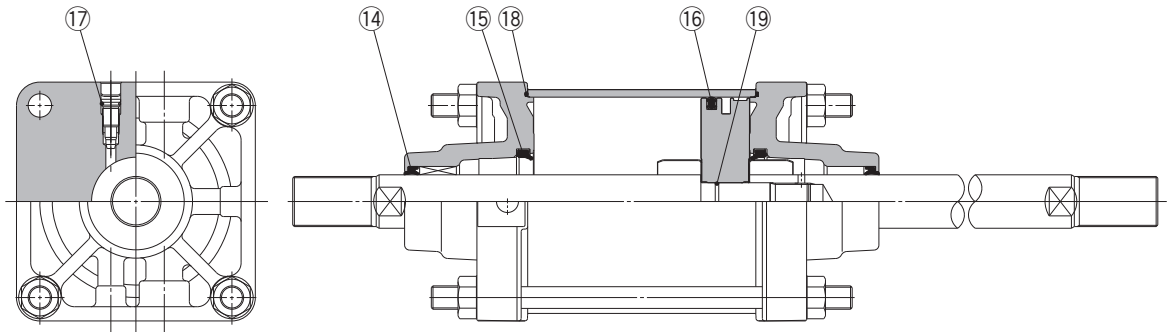

* The numbers are the same as the "Construction" of the CS2 series catalog (CAT.ES20-196).

Component Parts: Seal Kit List

No.	Description	Material	Note
14	Rod seal	NBR	17 and 19 are non-replaceable parts, so they are not included in the seal kit.
15	Cushion seal	Urethane	
16	Piston seal	NBR	
17	Valve seal	NBR	
18	Tube gasket	NBR	
19	Piston gasket	NBR	

Replacement Parts: Seal Kit

Bore size (mm)	Kit no.	Contents
125	CS2W125A-PS	Component part numbers: 14, 15, 16, 18.
140	CS2W140A-PS	
160	CS2W160A-PS	

* Seal kit includes a grease pack (40 g).
Order with the following part number when only the grease pack is needed.

Grease pack part no.: GR-S-010 (10 g), GR-S-020 (20 g)

Actuators

Modular F.R.L.
Pressure Control Equipment

Air Preparation
Equipment

Industrial Filters

Replacement
Procedure

Actuators

Modular F.R.L.
Pressure Control Equipment

Industrial Filters

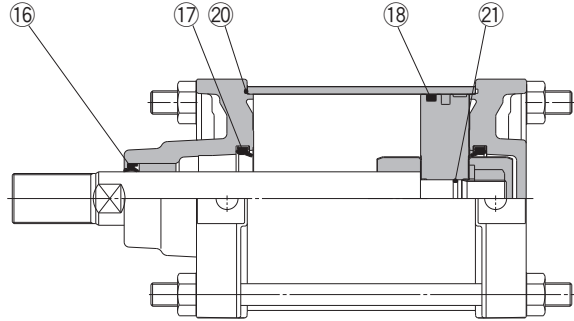
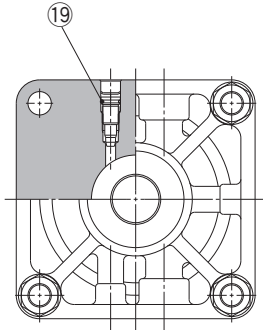
Construction

* The numbers are the same as the "Construction" of the Best Pneumatics No.3 Series CS2Y.

Seal Kit List

No.	Description	Material	Note
16	Rod seal	NBR	19 and 21 are non-replaceable parts, so they are not included in the seal kit.
17	Cushion seal *	Urethane	
18	Piston seal	NBR	
19	Valve seal	NBR	
20	Tube gasket	NBR	
21	Piston gasket	NBR	

* Used with cushion only.

Replacement Parts: Seal Kit

Bore size (mm)	Kit no.	Contents
125	CS2Y125A-PS	Without cushion
140	CS2Y140A-PS	Consists of component part numbers 16, 18, and 20.
160	CS2Y160A-PS	
125	CS2Y125AA-PS	With single-side cushion
140	CS2Y140AA-PS	Consists of component part numbers 16, 17 (two), 18, and 20.
160	CS2Y160AA-PS	
125	CS2Y125AR-PS	With single-side cushion
140	CS2Y140AR-PS	Consists of component part numbers 16, 17 (one), 18 and 20.
160	CS2Y160AR-PS	

* Seal kit does not include a grease pack.

Order with the following part number when only the grease pack is needed.

Grease pack part no.: GR-L-005 (5 g), GR-S-010 (10 g), GR-L-150 (150g)

Mini Free Mount Cylinder

Series CUJ

ø4, ø6, ø8, ø10

Replacement
Procedure is
P.289

Construction

Double acting

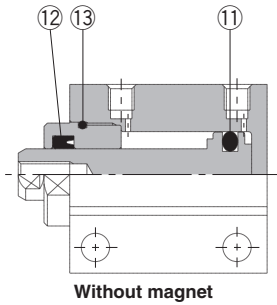

Single acting, spring return

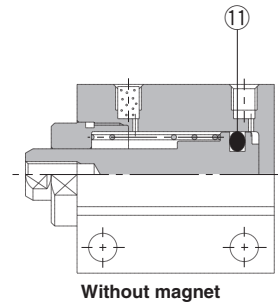

* The numbers are the same as the "Construction" of the Best Pneumatics No.2 Series CUJ.

Seal Kit List

No.	Description	Material	Note
①	Piston seal	NBR	
⑫	Rod seal		
⑬	Tube gasket		

Replacement Parts: Seal Kit

Bore size (mm)	Kit no.	Contents
Double acting		
4	CUJB4-PS	Set of left nos. ①, ⑫, ⑬ and grease pack.
6	CUJB6-PS	
8	CUJB8-PS	
10	CUJB10-PS	

* Seal kit ① to ⑬ comes as a set. Use the kit number for each bore size.

Single acting, spring return

4	CUJB4-S-PS	Set of left nos. ① and grease pack.
6	CUJB6-S-PS	
8	CUJB8-S-PS	
10	CUJB10-S-PS	

* Use the following part number for ordering a grease pack only.

Grease pack part no.: GR-L-005 (5 g)

Actuators

Modular F.R.L.
Pressure Control Equipment

Air Preparation
Equipment

Industrial Filters

Replacement
Procedure

Actuators

Modular F.R.L.
Pressure Control Equipment

Industrial Filters

Mini Free Mount Cylinder

Series CUJ

ø12, ø16, ø20



Construction

Double acting

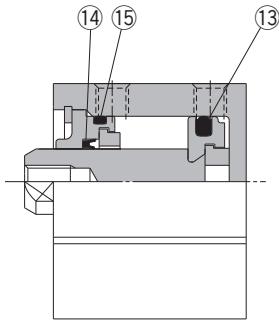

Without magnet

Single acting, spring return

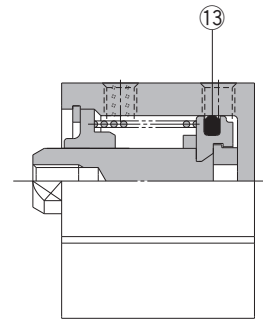

Without magnet

* The numbers are the same as the "Construction" of the Best Pneumatics No.2 Series CUJ.

Seal Kit List

No.	Description	Material	Note
⑬	Piston seal	NBR	
⑭	Rod seal		
⑮	O-ring		

Replacement Parts: Seal Kit

Bore size (mm)	Kit no.	Contents
Double acting		
12	CUJB12-PS	Set of left nos. ⑬, ⑭, ⑮ and grease pack.
16	CUJB16-PS	
20	CUJB20-PS	

* Seal kit ⑬ to ⑮ comes as a set. Use the kit number for each bore size.

Single acting, spring return

12	CUJB12-S-PS	Set of left nos. ⑬ and grease pack.
16	CUJB16-S-PS	
20	CUJB20-S-PS	

* Use the following part number for ordering a grease pack only.

Grease pack part no.: GR-L-005 (5 g)

Series CU

ø10, ø16, ø20, ø25, ø32

Construction

With auto switch

ø10

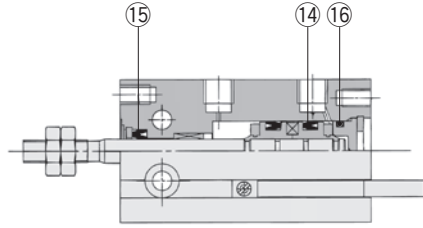
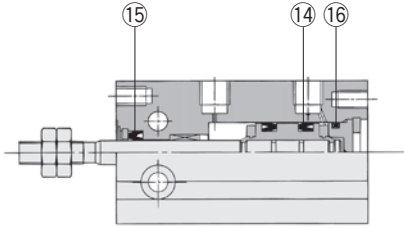

ø16 to ø32

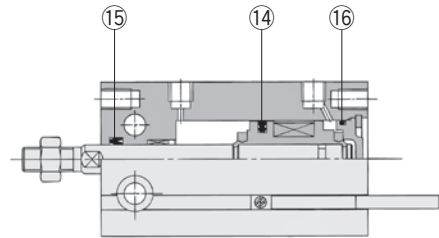
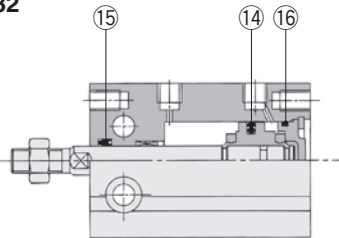

* The numbers are the same as the "Construction" of the Best Pneumatics No.2 Series CU.

Seal Kit List

No.	Description	Material	Note
14	Piston seal	NBR	
15	Rod seal		
16	Gasket		

Replacement Parts: Seal Kit

Bore size (mm)	Kit no.	Contents
10	CU10D-PS	Set of left nos. 14, 15, 16.
16	CU16D-PS	
20	CU20D-PS	
25	CU25D-PS	
32	CU32D-PS	

* ø6 cannot be repaired.

* Seal kit includes 14, 15, 16. Order the seal kit, based on each bore size.

* Seal kit includes a grease pack (10 g).

Order with the following part number when only the grease pack is needed.

Grease pack part no.: GR-S-010 (10 g)

Actuators

Modular F.R.L.
Pressure Control Equipment

Air Preparation
Equipment

Industrial Filters

Replacement
Procedure

Actuators

Modular F.R.L.
Pressure Control Equipment

Industrial Filters

Series CUW

ø10, ø16, ø20, ø25, ø32

Construction

With auto switch

ø10

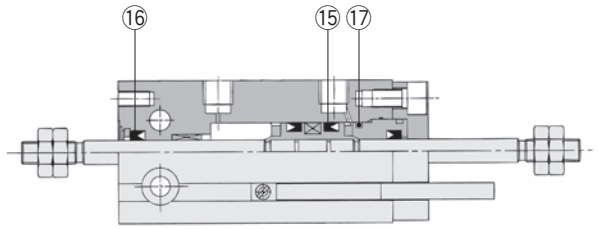
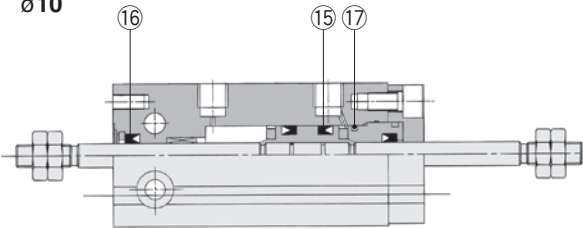

ø16 to ø32

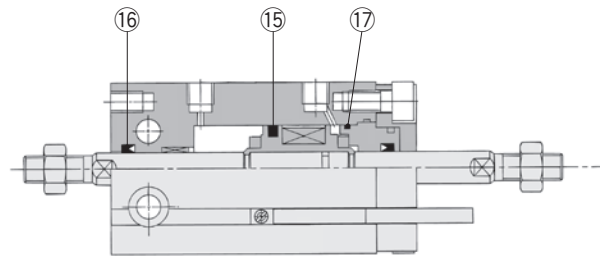
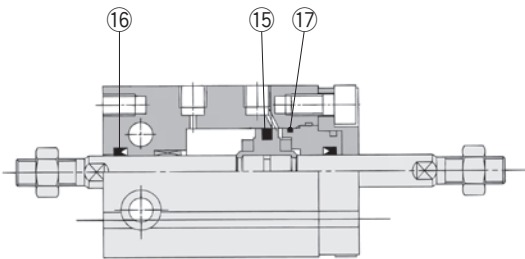

* The numbers are the same as the "Construction" of the Best Pneumatics No.2 Series CUW.

Seal Kit List

No.	Description	Material	Note
15	Piston seal	NBR	
16	Rod seal		
17	Gasket		

Replacement Parts: Seal Kit

Bore size (mm)	Kit no.	Contents
10	CUW10D-PS	Set of left nos. 15, 16, 17.
16	CUW16D-PS	
20	CUW20D-PS	
25	CUW25D-PS	
32	CUW32D-PS	

* ø6 cannot be repaired.

* Seal kit includes 15, 16, 17. Order the seal kit, based on each bore size.

* Seal kit includes a grease pack (10 g).

Order with the following part number when only the grease pack is needed.

Grease pack part no.: GR-S-010 (10 g)

Series CU

ø10, ø16, ø20, ø25, ø32

Construction

Single acting, spring return

ø10

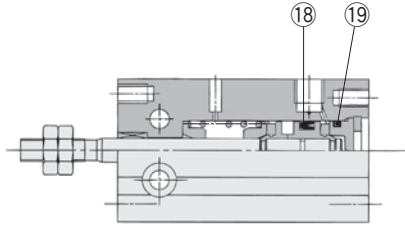

ø16 to ø32

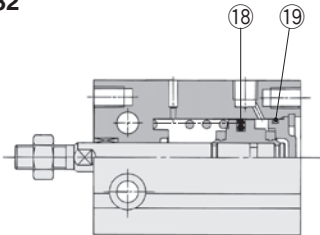

With auto switch

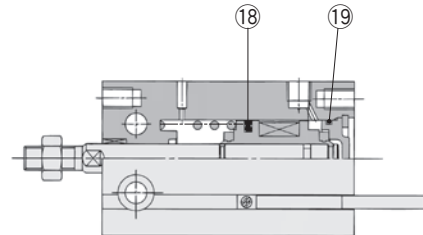
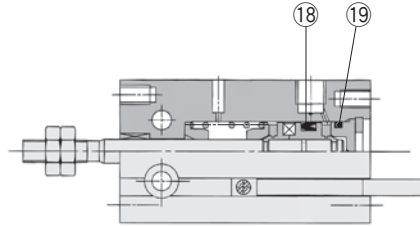

* The numbers are the same as the "Construction" of the Best Pneumatics No.2 Series CU.

Seal Kit List

No.	Description	Material	Note
18	Piston seal	NBR	
19	Gasket		

Replacement Parts: Seal Kit

Bore size (mm)	Kit no.	Contents
10	CU10S-PS	Set of left nos. 18, 19.
16	CU16S-PS	
20	CU20S-PS	
25	CU25S-PS	
32	CU32S-PS	

* ø6 cannot be repaired.

* Seal kit includes 18, 19. Order the seal kit, based on each bore size.

* Seal kit includes a grease pack (10 g).

Order with the following part number when only the grease pack is needed.

Grease pack part no.: GR-S-010 (10 g)

Actuators

Modular F.R.L.
Pressure Control Equipment

Air Preparation
Equipment

Industrial Filters

Replacement
Procedure

Actuators

Modular F.R.L.
Pressure Control Equipment

Industrial Filters

Free Mount Cylinder/Single Acting, Single Rod, Spring Extend

Series CU

ø10, ø16, ø20, ø25, ø32

Construction

Single acting, spring extend

ø10

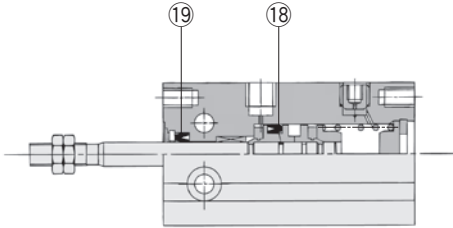

With auto switch

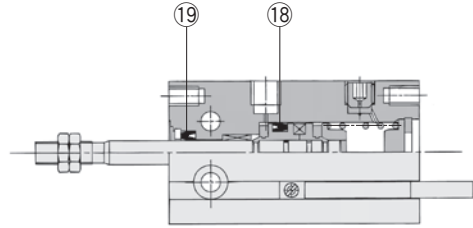

ø16 to ø32

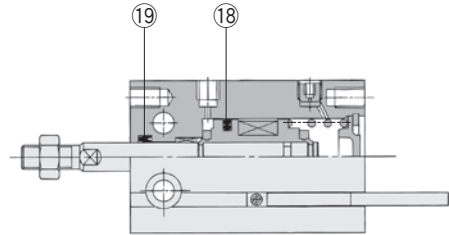
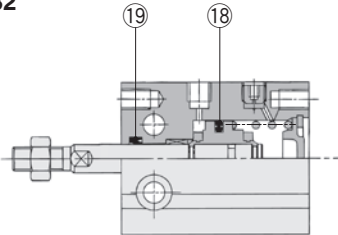

* The numbers are the same as the "Construction" of the Best Pneumatics No.2 Series CU.

Seal Kit List

No.	Description	Material	Note
18	Piston seal	NBR	
19	Rod seal		

Replacement Parts: Seal Kit

Bore size (mm)	Kit no.	Contents
10	CU10T-PS	Set of left nos. 18, 19.
16	CU16T-PS	
20	CU20T-PS	
25	CU25T-PS	
32	CU32T-PS	

* ø6 cannot be repaired.

* Seal kit includes 18, 19. Order the seal kit, based on each bore size.

* Seal kit includes a grease pack (10 g).

Order with the following part number when only the grease pack is needed.

Grease pack part no.: GR-S-010 (10 g)

Series CUK

ø10, ø16, ø20, ø25, ø32

Construction

With auto switch

ø10

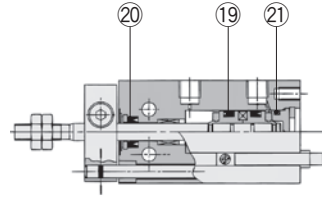
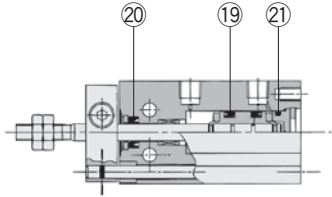

ø16 to ø32

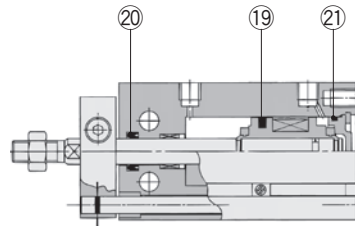
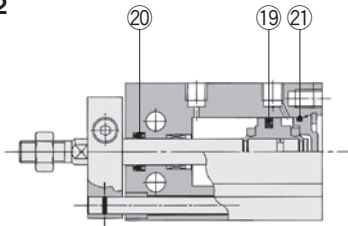

* The numbers are the same as the "Construction" of the Best Pneumatics No.2 Series CUK.

Seal Kit List

No.	Description	Material	Note
19	Piston seal	NBR	
20	Rod seal		
21	Gasket		

Replacement Parts: Seal Kit

Bore size (mm)	Kit no.	Contents
10	CU10D-PS	Set of left nos. 19, 20, 21.
16	CU16D-PS	
20	CU20D-PS	
25	CU25D-PS	
32	CU32D-PS	

* ø6 cannot be repaired.

* Seal kit includes 19, 20, 21. Order the seal kit, based on each bore size.

* Seal kit includes a grease pack (10 g).

Order with the following part number when only the grease pack is needed.

Grease pack part no.: GR-S-010 (10 g)

Actuators

Modular F.R.L.
Pressure Control Equipment

Air Preparation
Equipment

Industrial Filters

Replacement
Procedure

Actuators

Modular F.R.L.
Pressure Control Equipment

Industrial Filters

Series CUKW

ø10, ø16, ø20, ø25, ø32

Construction

With auto switch

ø10

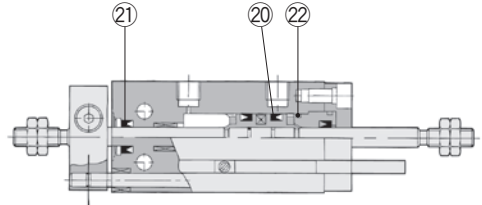
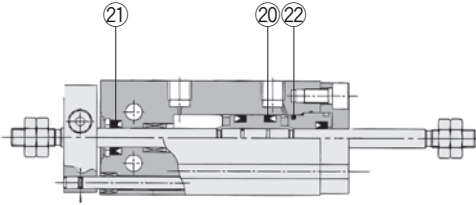

ø16 to ø32

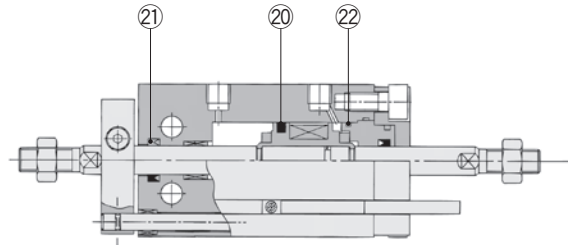
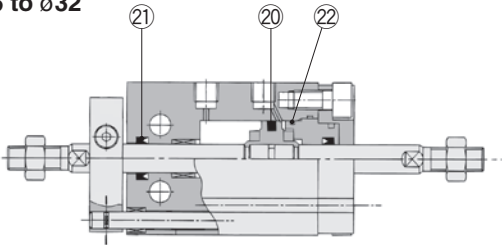

* The numbers are the same as the "Construction" of the Best Pneumatics No.2 Series CUKW.

Seal Kit List

No.	Description	Material	Note
20	Piston seal	NBR	
21	Rod seal		
22	Gasket		

Replacement Parts: Seal Kit

Bore size (mm)	Kit no.	Contents
10	CUW10D-PS	Set of left nos. 20, 21, 22.
16	CUW16D-PS	
20	CUW20D-PS	
25	CUW25D-PS	
32	CUW32D-PS	

* ø6 cannot be repaired.

* Seal kit includes 20, 21, 22. Order the seal kit, based on each bore size.

* Seal kit includes a grease pack (10 g).

Order with the following part number when only the grease pack is needed.

Grease pack part no.: GR-S-010 (10 g)

Series CUK

ø10, ø16, ø20, ø25, ø32

Construction

Single acting, spring return

ø10

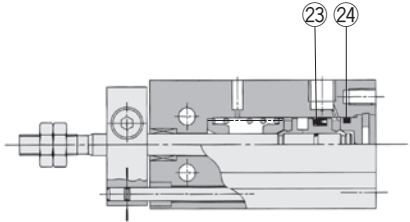

With auto switch

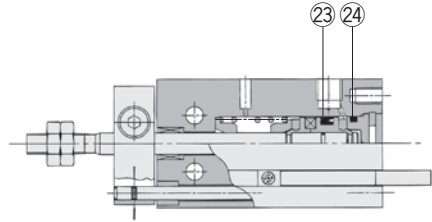

ø16 to ø32

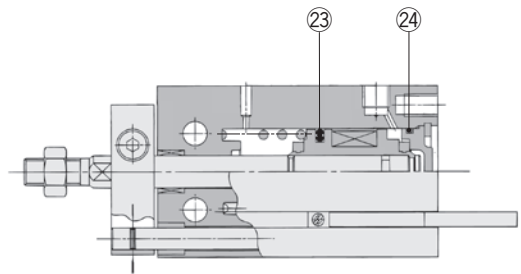
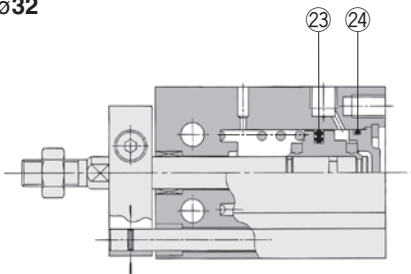

* The numbers are the same as the "Construction" of the Best Pneumatics No.2 Series CUK.

Seal Kit List

No.	Description	Material	Note
23	Piston seal	NBR	
24	Gasket		

Replacement Parts: Seal Kit

Bore size (mm)	Kit no.	Contents
10	CU10S-PS	Set of left nos. 23, 24.
16	CU16S-PS	
20	CU20S-PS	
25	CU25S-PS	
32	CU32S-PS	

* ø6 cannot be repaired.

* Seal kit includes 23, 24. Order the seal kit, based on each bore size.

* Seal kit includes a grease pack (10 g).

Order with the following part number when only the grease pack is needed.

Grease pack part no.: GR-S-010 (10 g)

Actuators

Modular F.R.L.
Pressure Control Equipment

Air Preparation
Equipment

Industrial Filters

Replacement
Procedure

Actuators

Modular F.R.L.
Pressure Control Equipment

Industrial Filters

Series CUK

ø10, ø16, ø20, ø25, ø32

Construction

Single acting, spring extend

ø10

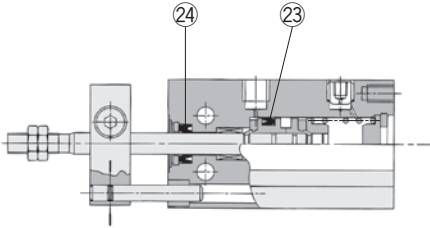

With auto switch

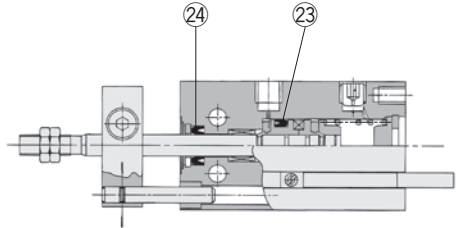

ø16 to ø32

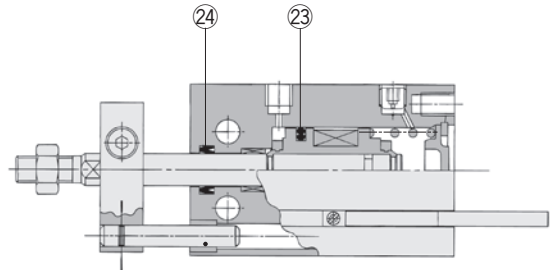
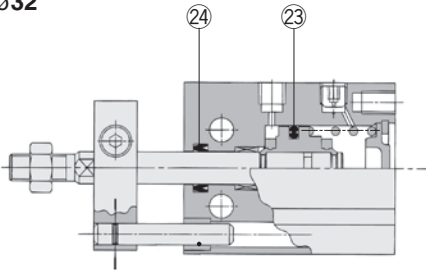

* The numbers are the same as the "Construction" of the Best Pneumatics No.2 Series CUK.

Seal Kit List

No.	Description	Material	Note
23	Piston seal	NBR	
24	Rod seal		

Replacement Parts: Seal Kit

Bore size (mm)	Kit no.	Contents
10	CU10T-PS	Set of left nos. 23, 24.
16	CU16T-PS	
20	CU20T-PS	
25	CU25T-PS	
32	CU32T-PS	

* ø6 cannot be repaired.

* Seal kit includes 23, 24. Order the seal kit, based on each bore size.

* Seal kit includes a grease pack (10 g).

Order with the following part number when only the grease pack is needed.

Grease pack part no.: GR-S-010 (10 g)

Series CU

ø10, ø16, ø20, ø25, ø32

Construction

With auto switch

ø10

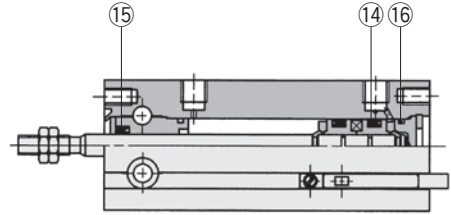
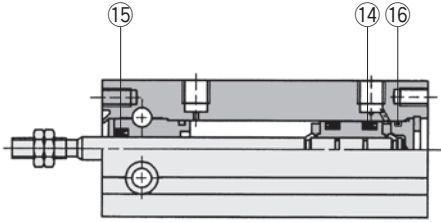

ø16 to ø32

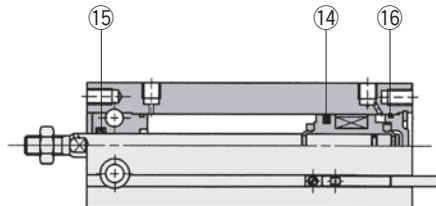
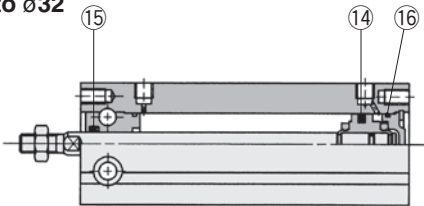

* The numbers are the same as the "Construction" of the Best Pneumatics No.2 Series CU.

Seal Kit List

No.	Description	Material	Note
14	Piston seal	NBR	
15	Rod seal		
16	Gasket		

Replacement Parts: Seal Kit

Bore size (mm)	Kit no.	Contents
10	CU10D-PS	Set of left nos. 14, 15, 16.
16	CU16D-PS	
20	CU20D-PS	
25	CU25D-PS	
32	CU32D-PS	

* ø6 cannot be repaired.

* Seal kit includes 14, 15, 16. Order the seal kit, based on each bore size.

* Seal kit includes a grease pack (10 g).

Order with the following part number when only the grease pack is needed.

Grease pack part no.: GR-S-010 (10 g)

Series CUK

ø10, ø16, ø20, ø25, ø32

Construction

With auto switch

ø10

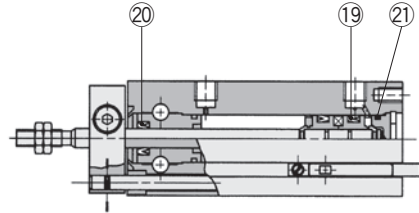
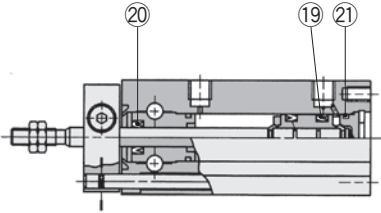

ø16 to ø32

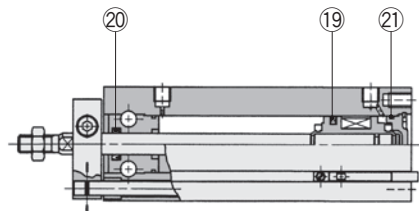
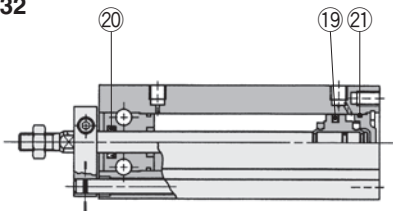

* The numbers are the same as the "Construction" of the Best Pneumatics No.2 Series CUK.

Seal Kit List

No.	Description	Material	Note
19	Piston seal	NBR	
20	Rod seal		
21	Gasket		

Replacement Parts: Seal Kit

Bore size (mm)	Kit no.	Contents
10	CU10D-PS	Set of left nos. 19, 20, 21.
16	CU16D-PS	
20	CU20D-PS	
25	CU25D-PS	
32	CU32D-PS	

* ø6 cannot be repaired.

* Seal kit includes 19, 20, 21. Order the seal kit, based on each bore size.

* Seal kit includes a grease pack (10 g).

Order with the following part number when only the grease pack is needed.

Grease pack part no.: GR-S-010 (10 g)

Series CU ø20, ø25, ø32

Construction

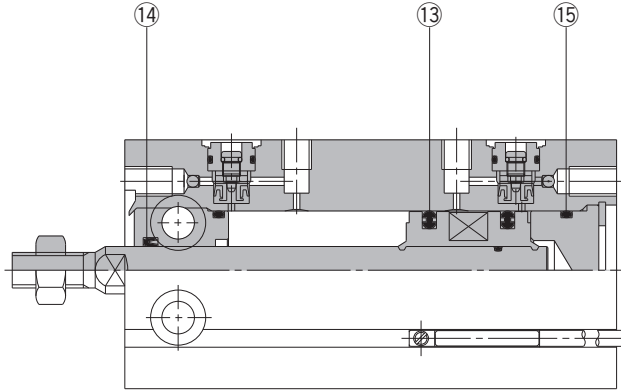

* The numbers are the same as the "Construction" of the Best Pneumatics No.2 Series CU.

Seal Kit List

No.	Description	Material	No. of pcs.	Note
13	Piston seal	NBR	2	
14	Rod seal		1	
15	Gasket		1	

Replacement Parts: Seal Kit

Bore size (mm)	Kit no.	Contents
ø20	CU20A-PS	Set of left nos. 13, 14, 15.
ø25	CU25A-PS	
ø32	CU32A-PS	

* Seal kit includes 13, 14, 15. Order the seal kit, based on each bore size.

* Seal kit includes a grease pack (10 g).

Order with the following part number when only the grease pack is needed.

Grease pack part no.: GR-S-010 (10 g)

Free Mount Cylinder for Vacuum

Series ZCUK

Construction

Cap piping, male thread: ZC(D)UKC

With auto switch

ø10

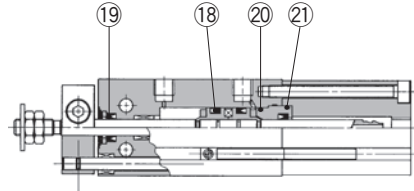
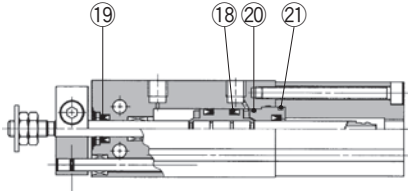

ø16 to ø32

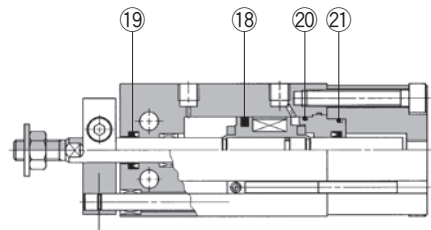
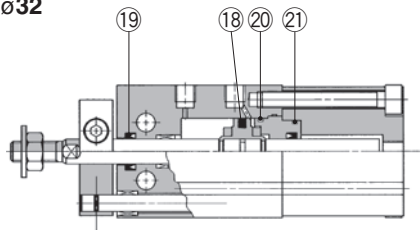

* The numbers are the same as the "Construction" of the Best Pneumatics No.2 Series ZCUK.

Seal Kit List

No.	Description	Material	Note
18	Piston seal	NBR	
19	Rod seal		
20	Gasket		
21	Gasket for cap		

Replacement Parts: Seal Kit

Bore size (mm)	Kit no.	Contents
10	ZCU10-PS	Set of left nos. 18, 19, 20, 21.
16	ZCU16-PS	
20	ZCU20-PS	
25	ZCU25-PS	
32	ZCU32-PS	

* Seal kit includes 18, 19, 20 and 21. Order the seal kit based on each bore size.

* Seal kit includes a grease pack (10 g).

Order with the following part number when only the grease pack is needed.

Grease pack part no.: GR-S-010 (10 g)

Free Mount Cylinder for Vacuum

Series ZCUK

Construction

Rod piping, male thread: ZC(D)UKQ

With auto switch

ø10

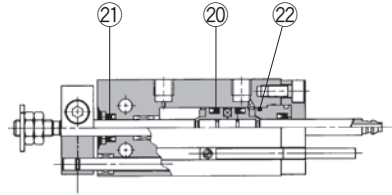
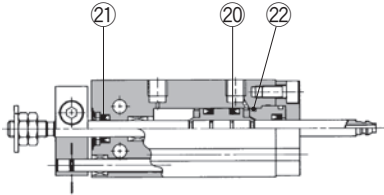

ø16 to ø32

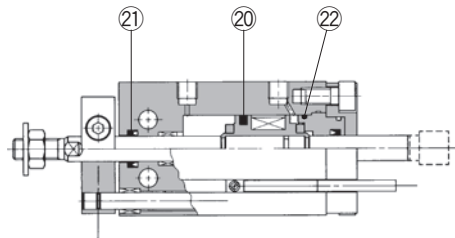
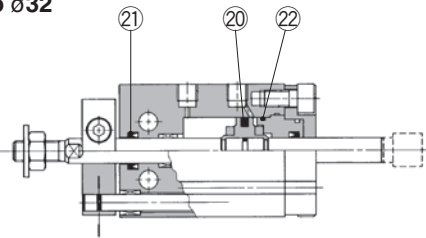

* The numbers are the same as the "Construction" of the Best Pneumatics No.2 Series ZCUK.

Seal Kit List

No.	Description	Material	Note
20	Piston seal	NBR	
21	Rod seal		
22	Gasket		

Replacement Parts: Seal Kit

Bore size (mm)	Kit no.	Contents
10	CUW10D-PS	Set of left nos. 20, 21, 22.
16	CUW16D-PS	
20	CUW20D-PS	
25	CUW25D-PS	
32	CUW32D-PS	

* Seal kit includes 20, 21 and 22. Order the seal kit based on each bore size.

* Seal kit includes a grease pack (10 g).

Order with the following part number when only the grease pack is needed.

Grease pack part no.: GR-S-010 (10 g)

Actuators

Modular F.R.L.
Pressure Control Equipment

Air Preparation
Equipment

Industrial Filters

Replacement
Procedure

Actuators

Modular F.R.L.
Pressure Control Equipment

Industrial Filters

Compact Cylinder/Standard Type: Double Acting, Single Rod

Series CQS

ø12, ø16, ø20, ø25

Replacement
Procedure is
P.290

Construction

Basic style

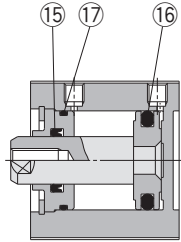

* The numbers are the same as the "Construction" of the Best Pneumatics No.2 Series CQS.

Seal Kit List

No.	Description	Material	Note
15	Rod seal	NBR	
16	Piston seal		
17	Tube gasket		

Replacement Parts: Seal Kit

Bore size (mm)	Kit no.	Contents
Basic style		
12	CQSB12-PS	Set of left nos. 15, 16, 17.
16	CQSB16-PS	
20	CQSB20-PS	
25	CQSB25-PS	
Long stroke		
12	CQSB12-L-PS	Set of left nos. 15, 16, 17.
16	CQSB16-L-PS	
20	CQSB20-L-PS	
25	CQSB25-L-PS	

* Seal kit includes 15, 16, 17. Order the seal kit, based on each bore size.
(The long stroke type includes 2 tube gaskets.)

* Since the seal kit does not include a grease pack, order it separately.

Grease pack part no.: GR-S-010 (10 g)

Series CQSW

ø12, ø16
ø20, ø25

Replacement
Procedure is
P.290

Construction

Basic style

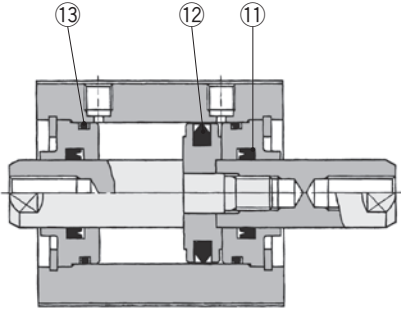

With auto switch (built-in magnet)

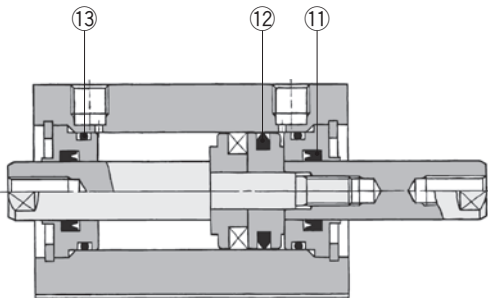

ø12, ø16

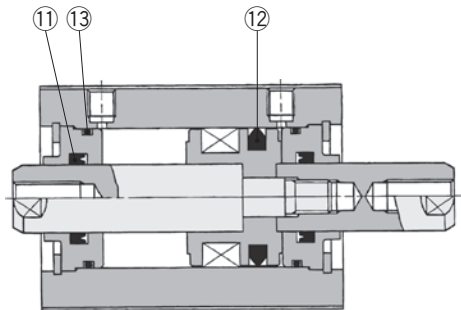

ø20, ø25

* The numbers are the same as the "Construction" of the Best Pneumatics No.2 Series CQSW.

Seal Kit List

No.	Description	Material	Note
①	Rod seal	NBR	
②	Piston seal		
③	Tube gasket		

Replacement Parts: Seal Kit

Bore size (mm)	Kit no.	Contents
12	CQSWB12-PS	Set of left nos. ①, ②, ③.
16	CQSWB16-PS	
20	CQSWB20-PS	
25	CQSWB25-PS	

* Seal kit includes ①, ②, ③. Order the seal kit, based on each bore size.

* Since the seal kit does not include a grease pack, order it separately.

Grease pack part no.: GR-S-010 (10 g)

Actuators

Modular F.R.L.
Pressure Control Equipment

Air Preparation
Equipment

Industrial Filters

Replacement
Procedure

Actuators

Modular F.R.L.
Pressure Control Equipment

Industrial Filters

Compact Cylinder/Standard Type: Single Acting, Single Rod

Series CQS

ø12, ø16, ø20, ø25

Replacement
Procedure is
P.290

Construction

Single acting,
spring return

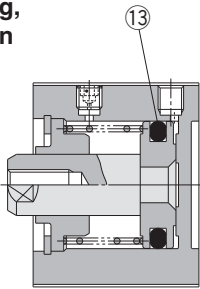

Single acting,
spring extend

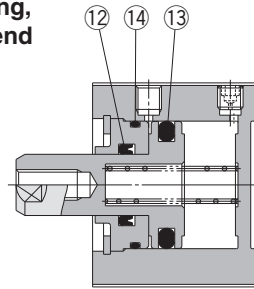

Single acting, spring return/
with auto switch (built-in magnet)

ø12, ø16

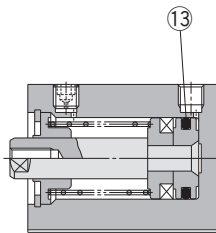

Single acting, spring extend/
with auto switch (built-in magnet)

ø12, ø16

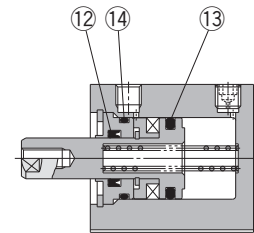

ø20, ø25

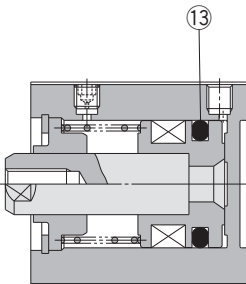

ø20, ø25

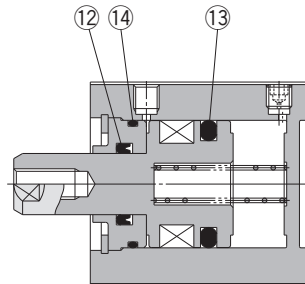

* The numbers are the same as the "Construction" of the Best Pneumatics No.2 Series CQS.

Seal Kit List

No.	Description	Material	Note
12	Rod seal	NBR	
13	Piston seal		
14	Tube gasket		

Replacement Parts: Seal Kit

Bore size (mm)	Kit no.	Contents
Single acting, spring return		
12	CQSB12-S-PS	Left no. 13
16	CQSB16-S-PS	
20	CQSB20-S-PS	
25	CQSB25-S-PS	

* Seal kit includes 13. Order the seal kit, based on each bore size.

* Since the seal kit does not include a grease pack, order it separately.
Grease pack part no.: GR-S-010 (10 g)

Single acting, spring extend

12	CQSB12-T-PS	Set of left nos. 12, 13, 14.
16	CQSB16-T-PS	
20	CQSB20-T-PS	
25	CQSB25-T-PS	

* Seal kit includes 12, 13, 14. Order the seal kit, based on each bore size.

* Since the seal kit does not include a grease pack, order it separately.
Grease pack part no.: GR-S-010 (10 g)

Series CQSK

ø12, ø16, ø20, ø25

Replacement Procedure is P.290

Construction

Basic style

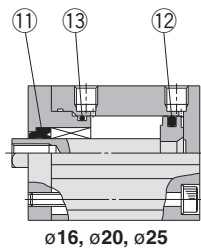
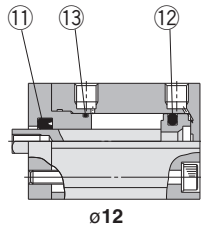

With auto switch (built-in magnet)

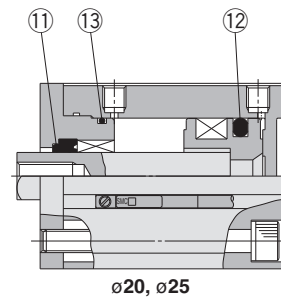
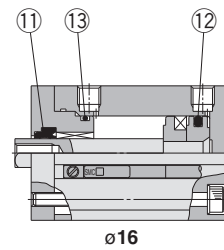
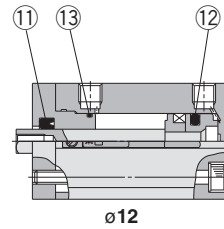

* The numbers are the same as the "Construction" of the Best Pneumatics No.2 Series CQSK.

Seal Kit List

No.	Description	Material	Note
①	Rod seal	NBR	
②	Piston seal		
③	Tube gasket		

Replacement Parts: Seal Kit

Bore size (mm)	Kit no.	Contents
12	CQSKB12-PS	Set of left nos. ①, ②, ③.
16	CQSKB16-PS	
20	CQSKB20-PS	
25	CQSKB25-PS	

* Seal kit includes ①, ②, ③. Order the seal kit, based on each bore size.
 * Since the seal kit does not include a grease pack, order it separately.
Grease pack part no.: GR-S-010 (10 g)

Actuators

Modular F.R.L.
Pressure Control Equipment

Air Preparation Equipment

Industrial Filters

Replacement Procedure

Actuators

Modular F.R.L.
Pressure Control Equipment

Industrial Filters

Series CQSKW

ø12, ø16
ø20, ø25

Replacement
Procedure is
P.290

Construction

Basic style

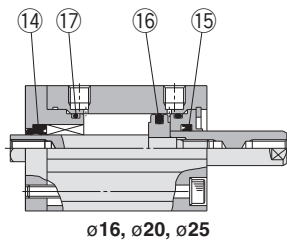
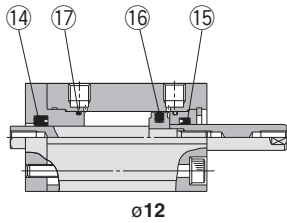

With auto switch (built-in magnet)

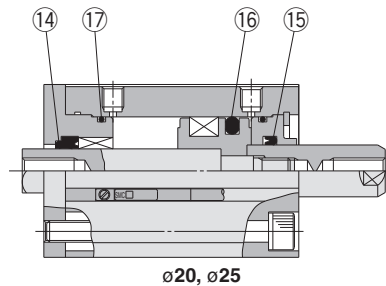
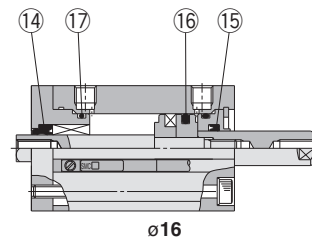
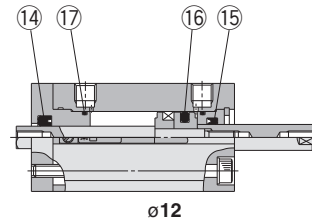

* The numbers are the same as the "Construction" of the Best Pneumatics No.2 Series CQSKW.

Seal Kit List

No.	Description	Material	Note
⑭	Rod seal for non-rotating	NBR	
⑮	Rod seal		
⑯	Piston seal		
⑰	Tube gasket		

Replacement Parts: Seal Kit

Bore size (mm)	Kit no.	Contents
12	CQSKWB12-PS	Set of left nos. ⑭, ⑮, ⑯, ⑰.
16	CQSKWB16-PS	
20	CQSKWB20-PS	
25	CQSKWB25-PS	

* Seal kit includes ⑭, ⑮, ⑯, ⑰. Order the seal kit, based on each bore size.

* Since the seal kit does not include a grease pack, order it separately.
Grease pack part no.: GR-S-010 (10 g)

Series CQS□S

ø12, ø16
ø20, ø25

Replacement
Procedure is
P.290

Construction

Basic style

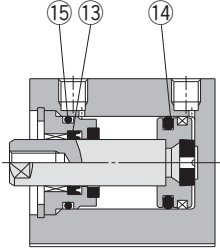

With auto switch (built-in magnet)

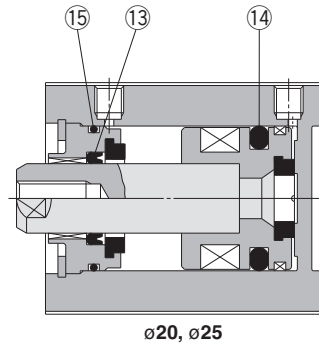
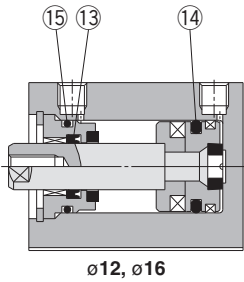

* The numbers are the same as the "Construction" of the Best Pneumatics No.2 Series CQS□S.

Seal Kit List

No.	Description	Material	Note
⑬	Rod seal	NBR	
⑭	Piston seal		
⑮	Tube gasket		

Replacement Parts: Seal Kit

Bore size (mm)	Kit no.	Contents
12	CQSB12-PS	Set of left nos. ⑬, ⑭, ⑮.
16	CQSB16-PS	
20	CQSB20-PS	
25	CQSB25-PS	

* Seal kit includes ⑬, ⑭, ⑮. Order the seal kit, based on each bore size.

* Since the seal kit does not include a grease pack, order it separately.

Grease pack part no.: GR-S-010 (10 g)

Actuators

Modular F.R.L.
Pressure Control Equipment

Air Preparation
Equipment

Industrial Filters

Replacement
Procedure

Actuators

Modular F.R.L.
Pressure Control Equipment

Industrial Filters

Series CQ2

ø12, ø16, ø20, ø25, ø32
ø40, ø50, ø63, ø80, ø100

Replacement
Procedure is
P.290

Construction

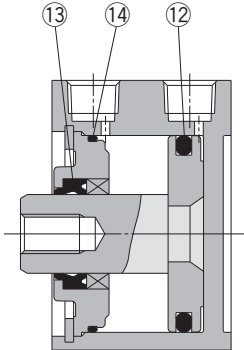

Without auto switch

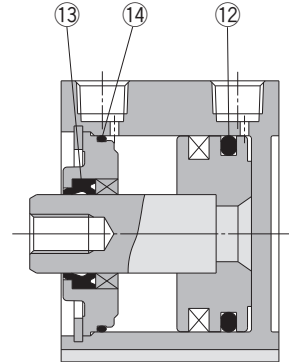

With auto switch

* The numbers are the same as the "Construction" of the CQ2 series catalog (CAT.ES20-205).

Seal Kit List

No.	Description	Material	Note
⑫	Piston seal	NBR	
⑬	Rod seal		
⑭	Gasket		

Replacement Parts: Seal Kit

Bore size (mm)	Kit no.	Contents
Pneumatic type		
12	CQ2B12-PS	Set of left nos. ⑫, ⑬, ⑭.
16	CQ2B16-PS	
20	CQ2B20-PS	
25	CQ2B25-PS	
32	CQ2B32-PS	
40	CQ2B40-PS	
50	CQ2B50-PS	
63	CQ2B63-PS	
80	CQ2B80-PS	
100	CQ2B100-PS	

* Seal kit includes ⑫, ⑬, ⑭. Order the seal kit, based on each bore size.

* Since the seal kit does not include a grease pack, order it separately.

Grease pack part no.: GR-S-010 (10 g)

Air-hydro type

20	CQ2BH20-PS	Set of left nos. ⑫, ⑬, ⑭.
25	CQ2BH25-PS	
32	CQ2BH32-PS	
40	CQ2BH40-PS	
50	CQ2BH50-PS	
63	CQ2BH63-PS	
80	CQ2BH80-PS	
100	CQ2BH100-PS	

* Seal kit includes ⑫, ⑬, ⑭. Order the seal kit, based on each bore size.

* Since the seal kit does not include a grease pack, order it separately.

Grease pack part no.: GR-S-010 (10 g)

Compact Cylinder/Standard Type: Double Acting, Double Rod

Series CQ2W

ø12, ø16, ø20
 ø25, ø32, ø40
 ø50, ø63, ø80
 ø100

Replacement
 Procedure is
 P.290

Construction

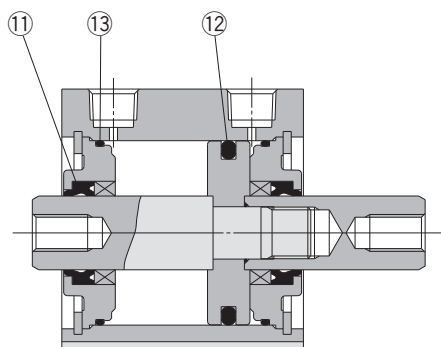

Without auto switch

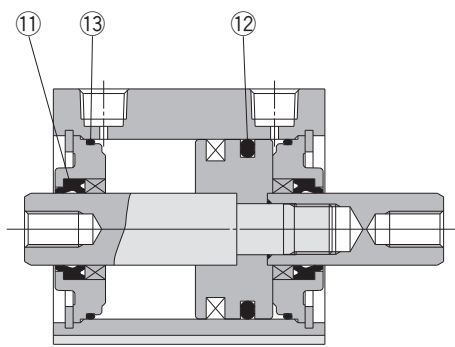

With auto switch

* The numbers are the same as the "Construction" of the CQ2 series catalog (CAT.ES20-205).

Seal Kit List

No.	Description	Material	Note
①	Rod seal	NBR	
②	Piston seal		
③	Tube gasket		

Replacement Parts: Seal Kit

Bore size (mm)	Kit no.	Contents
Pneumatic type		
12	CQ2WB12-PS	Set of left nos. ①, ②, ③.
16	CQ2WB16-PS	
20	CQ2WB20-PS	
25	CQ2WB25-PS	
32	CQ2WB32-PS	
40	CQ2WB40-PS	
50	CQ2WB50-PS	
63	CQ2WB63-PS	
80	CQ2WB80-PS	
100	CQ2WB100-PS	

* Seal kit includes ①, ②, ③. Order the seal kit, based on each bore size.

* Since the seal kit does not include a grease pack, order it separately.

Grease pack part no.: GR-S-010 (10 g)

Air-hydro type

20	CQ2WBH20-PS	Set of left nos. ①, ②, ③.
25	CQ2WBH25-PS	
32	CQ2WBH32-PS	
40	CQ2WBH40-PS	
50	CQ2WBH50-PS	
63	CQ2WBH63-PS	
80	CQ2WBH80-PS	
100	CQ2WBH100-PS	

* Seal kit includes ①, ②, ③. Order the seal kit, based on each bore size.

* Since the seal kit does not include a grease pack, order it separately.

Grease pack part no.: GR-S-010 (10 g)

Actuators

Modular F.R.L.
Pressure Control Equipment

Air Preparation
Equipment

Industrial Filters

Replacement
Procedure

Actuators

Modular F.R.L.
Pressure Control Equipment

Industrial Filters

Series CQ2

ø12, ø16, ø20, ø25
ø32, ø40, ø50

Replacement
Procedure is
P.290

Construction

Without auto switch

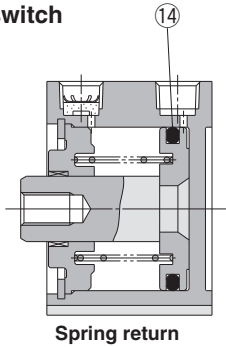

Spring return

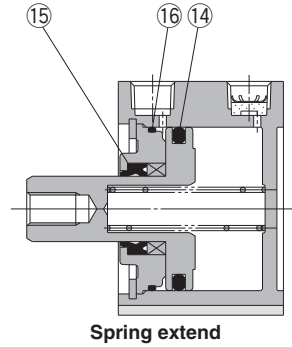

Spring extend

With auto switch

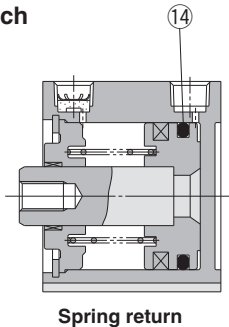

Spring return

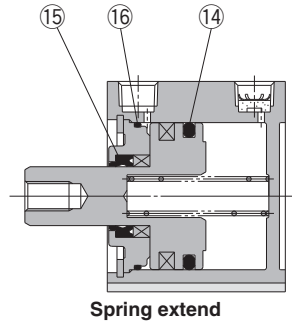

Spring extend

* The numbers are the same as the "Construction" of the CQ2 series catalog (CAT.ES20-205).

Seal Kit List

No.	Description	Material	Note
⑭	Piston seal	NBR	
⑮	Rod seal		
⑯	Gasket		

Replacement Parts: Seal Kit

Bore size (mm)	Kit no.	Contents
Single acting, spring return		
12	CQ2B12-S-PS	Left no. ⑭.
16	CQ2B16-S-PS	
20	CQ2B20-S-PS	
25	CQ2B25-S-PS	
32	CQ2B32-S-PS	
40	CQ2B40-S-PS	
50	CQ2B50-S-PS	

* Seal kit includes ⑭. Order the seal kit, based on each bore size.

* Since the seal kit does not include a grease pack, order it separately.

Grease pack part no.: GR-S-010 (10 g)

Single acting, spring extend

12	CQ2B12-T-PS	Set of left nos. ⑭, ⑮, ⑯.
16	CQ2B16-T-PS	
20	CQ2B20-T-PS	
25	CQ2B25-T-PS	
32	CQ2B32-T-PS	
40	CQ2B40-T-PS	
50	CQ2B50-T-PS	

* Seal kit includes ⑭, ⑮, ⑯. Order the seal kit, based on each bore size.

* Since the seal kit does not include a grease pack, order it separately.

Grease pack part no.: GR-S-010 (10 g)

Series CQ2

ø125, ø140, ø160
ø180, ø200

Replacement
Procedure is
P.290

Construction

Standard

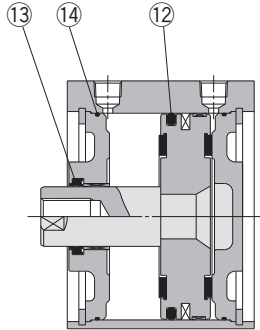

* The numbers are the same as the "Construction" of the CQ2 series catalog (CAT.ES20-205).

Seal Kit List

No.	Description	Material	Note
12	Piston seal	NBR	
13	Rod seal		
14	Tube gasket		

Replacement Parts: Seal Kit

Bore size (mm)	Kit no.	Contents
125	CQ2B125-PS	Set of left nos. 12, 13, 14.
140	CQ2B140-PS	
160	CQ2B160-PS	
180	CQ2B180-PS	
200	CQ2B200-PS	

* Seal kit includes 12, 13, 14. Order the seal kit, based on each bore size.

* Since the seal kit does not include a grease pack, order it separately.

Grease pack part no.: GR-S-010 (10 g)

Retaining Ring Installation/Removal

Caution

1. For installation and removal, use an appropriate pair of pliers (tool for installing a C retaining ring).
2. Even if a proper plier (tool for installing a C retaining ring) is used, it is likely to inflict damage to a human body or peripheral equipment, as a retaining ring may be flown out of the tip of a plier (tool for installing a C retaining ring). Be much careful with the popping of a retaining ring. Besides, be certain that a retaining ring is placed firmly into the groove of rod cover before supplying air at the time of installment.

Actuators

Modular F.R.L.
Pressure Control Equipment

Air Preparation
Equipment

Industrial Filters

Replacement
Procedure

Actuators

Modular F.R.L.
Pressure Control Equipment

Industrial Filters

Series CQ2W

∅125, ∅140, ∅160
∅180, ∅200



Construction

Standard

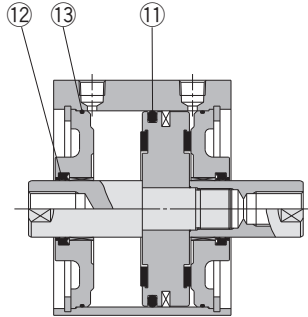

* The numbers are the same as the "Construction" of the CQ2 series catalog (CAT.ES20-205).

Seal Kit List

No.	Description	Material	Note
①	Piston seal	NBR	
⑫	Rod seal		
⑬	Tube gasket		

Replacement Parts: Seal Kit

Bore size (mm)	Kit no.	Contents
125	CQ2WB125-PS	Set of left nos. ①, ⑫, ⑬.
140	CQ2WB140-PS	
160	CQ2WB160-PS	
180	CQ2WB180-PS	
200	CQ2WB200-PS	

* Seal kit includes ①, ⑫, ⑬. Order the seal kit, based on each bore size.

* Since the seal kit does not include a grease pack, order it separately.

Grease pack part no.: GR-S-010 (10 g)

Series CQ2

ø32, ø40, ø50
ø63, ø80, ø100

Replacement
Procedure is
P.290

Construction

Standard

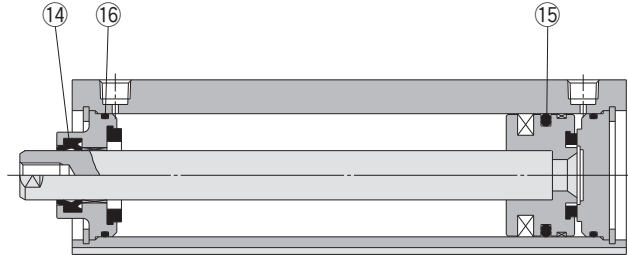

* The numbers are the same as the "Construction" of the CQ2 series catalog (CAT.ES20-205).

Seal Kit List

No.	Description	Material	Note
14	Rod seal	NBR	
15	Piston seal		
16	Tube gasket		

Replacement Parts: Seal Kit

Bore size (mm)	Kit no.	Contents
32	CQ2A32-L-PS	Set of left nos. 14, 15, 16.
40	CQ2A40-L-PS	
50	CQ2A50-L-PS	
63	CQ2A63-L-PS	
80	CQ2A80-L-PS	
100	CQ2A100-L-PS	

* Seal kit includes 14, 15, 16. Order the seal kit, based on each bore size.

* Since the seal kit does not include a grease pack, order it separately.

Grease pack part no.: GR-S-010 (10 g)

Retaining Ring Installation/Removal

⚠ Caution

1. For installation and removal, use an appropriate pair of pliers (tool for installing a C retaining ring).
2. Even if a proper plier (tool for installing a C retaining ring) is used, it is likely to inflict damage to a human body or peripheral equipment, as a retaining ring may be flown out of the tip of a plier (tool for installing a C retaining ring). Be much careful with the popping of a retaining ring. Besides, be certain that a retaining ring is placed firmly into the groove of rod cover before supplying air at the time of installment.

Actuators

Modular F.R.L.
Pressure Control Equipment

Air Preparation
Equipment

Industrial Filters

Replacement
Procedure

Actuators

Modular F.R.L.
Pressure Control Equipment

Industrial Filters

Series CQ2K

ø12, ø16, ø20, ø25
ø32, ø40, ø50, ø63

Replacement
Procedure is
P.290

Construction

Standard (ø40 to ø63)

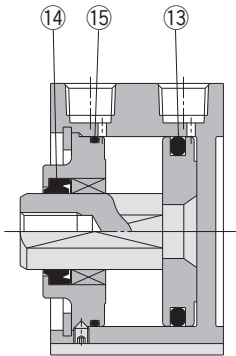

Without auto switch

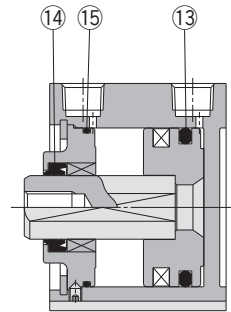

With auto switch

* The numbers are the same as the "Construction" of the CQ2 series catalog (CAT.ES20-205).

Seal Kit List

No.	Description	Material	Note
⑬	Piston seal	NBR	
⑭	Rod seal		
⑮	Tube gasket		

Replacement Parts: Seal Kit

Bore size (mm)	Kit no.	Contents
12	CQ2KB12-PS	Set of left nos. ⑬, ⑭, ⑮.
16	CQ2KB16-PS	
20	CQ2KB20-PS	
25	CQ2KB25-PS	
32	CQ2KB32-PS	
40	CQ2KB40-PS	
50	CQ2KB50-PS	
63	CQ2KB63-PS	

* Seal kit includes ⑬, ⑭, ⑮. Order the seal kit, based on each bore size.

* Since the seal kit does not include a grease pack, order it separately.

Grease pack part no.: GR-S-010 (10 g)

Series CQ2KW

ø12, ø16
ø20, ø25
ø32, ø40
ø50, ø63

Replacement
Procedure is
P.290

Construction

Standard (ø40 to ø63)

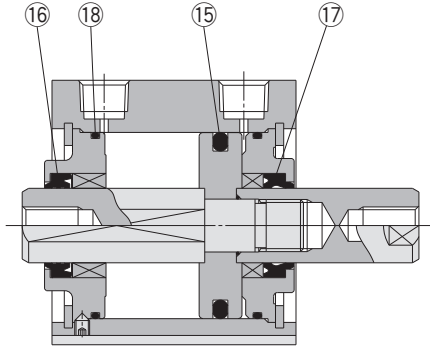

Without auto switch

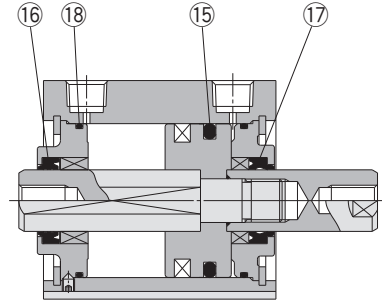

With auto switch

* The numbers are the same as the "Construction" of the CQ2 series catalog (CAT.ES20-205).

Seal Kit List

No.	Description	Material	Note
15	Piston seal	NBR	
16	Rod seal for non-rotating		
17	Rod seal		
18	Gasket		

Replacement Parts: Seal Kit

Bore size (mm)	Kit no.	Contents
12	CQ2KWB12-PS	Set of left nos. 15, 16, 17, 18.
16	CQ2KWB16-PS	
20	CQ2KWB20-PS	
25	CQ2KWB25-PS	
32	CQ2KWB32-PS	
40	CQ2KWB40-PS	
50	CQ2KWB50-PS	
63	CQ2KWB63-PS	

* Seal kit includes 15, 16, 17, 18. Order the seal kit, based on each bore size.

* Since the seal kit does not include a grease pack, order it separately.
Grease pack part no.: GR-S-010 (10 g)

Actuators

Modular F.R.L.
Pressure Control Equipment

Air Preparation
Equipment

Industrial Filters

Replacement
Procedure

Actuators

Modular F.R.L.
Pressure Control Equipment

Industrial Filters

Series CQP2

ø12, ø16, ø20, ø25
ø32, ø40, ø50, ø63
ø80, ø100

Replacement
Procedure is
P.290

Construction

Without auto switch

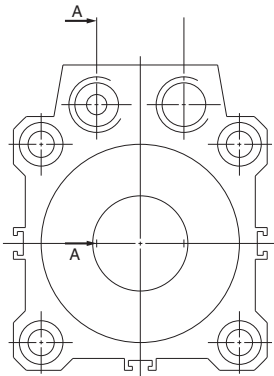
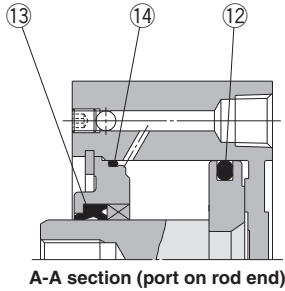

With auto switch

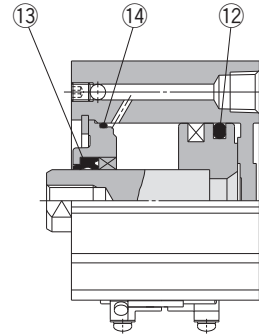

A-A section (port on rod end)

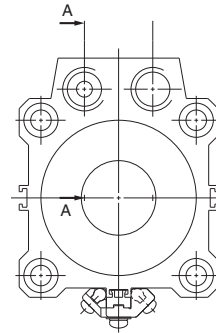

* The numbers are the same as the "Construction" of the CQ2 series catalog (CAT.ES20-205).

Seal Kit List

No.	Description	Material	Note
⑫	Piston seal	NBR	
⑬	Rod seal		
⑭	Gasket		

Replacement Parts: Seal Kit

Bore size (mm)	Kit no.	Contents
Pneumatic type (non-lube)		
12	CQ2B12-PS	Set of left nos. ⑫, ⑬, ⑭.
16	CQ2B16-PS	
20	CQ2B20-PS	
25	CQ2B25-PS	
32	CQ2B32-PS	
40	CQ2B40-PS	
50	CQ2B50-PS	
63	CQ2B63-PS	
80	CQ2B80-PS	
100	CQ2B100-PS	
Air-hydro type		
20	CQ2BH20-PS	Set of left nos. ⑫, ⑬, ⑭.
25	CQ2BH25-PS	
32	CQ2BH32-PS	
40	CQ2BH40-PS	
50	CQ2BH50-PS	
63	CQ2BH63-PS	
80	CQ2BH80-PS	
100	CQ2BH100-PS	

* Seal kit includes ⑫, ⑬, ⑭. Order the seal kit, based on each bore size.

* Since the seal kit does not include a grease pack, order it separately.

Grease pack part no.: GR-S-010 (10 g)

Series CQP2

ø12, ø16, ø20, ø25
ø32, ø40, ø50

Replacement
Procedure is
P.290

Construction

Without auto switch

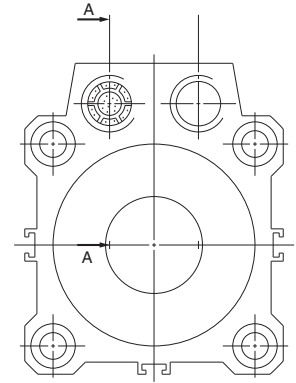
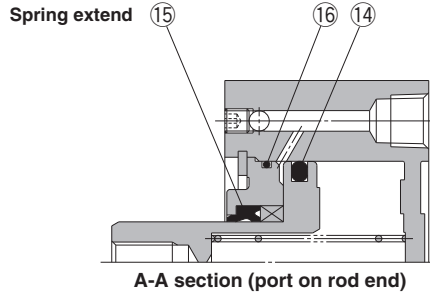
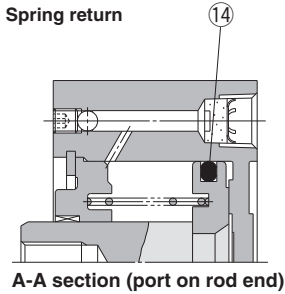

With auto switch

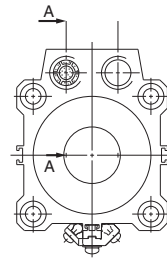
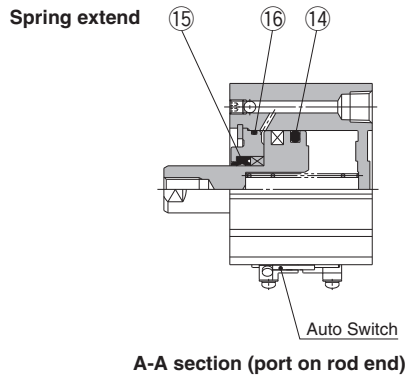
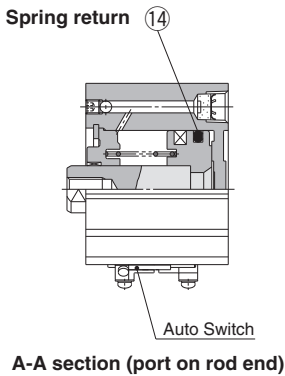

* The numbers are the same as the "Construction" of the CQ2 series catalog (CAT.ES20-205).

Seal Kit List

No.	Description	Material	Note
14	Piston seal	NBR	
15	Rod seal		
16	Gasket		

Replacement Parts: Seal Kit

Bore size (mm)	Kit no.	Contents
Single acting, spring return		
12	CQ2B12-S-PS	Set of left nos. 14.
16	CQ2B16-S-PS	
20	CQ2B20-S-PS	
25	CQ2B25-S-PS	
32	CQ2B32-S-PS	
40	CQ2B40-S-PS	
50	CQ2B50-S-PS	

* Seal kit includes 14. Order the seal kit, based on each bore size.
* Since the seal kit does not include a grease pack, order it separately.
Grease pack part no.: GR-S-010 (10 g)

Replacement Parts: Seal Kit

Bore size (mm)	Kit no.	Contents
Single acting, spring extend		
12	CQ2B12-T-PS	Set of left nos. 14, 15, 16.
16	CQ2B16-T-PS	
20	CQ2B20-T-PS	
25	CQ2B25-T-PS	
32	CQ2B32-T-PS	
40	CQ2B40-T-PS	
50	CQ2B50-T-PS	

* Seal kit includes 14, 15, 16. Order the seal kit, based on each bore size.
* Since the seal kit does not include a grease pack, order it separately.
Grease pack part no.: GR-S-010 (10 g)

Series CQ2

ø32, ø40, ø50
ø63, ø80, ø100



Construction

Standard

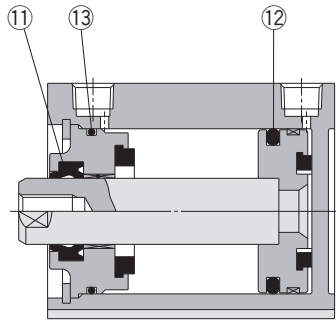

Without auto switch

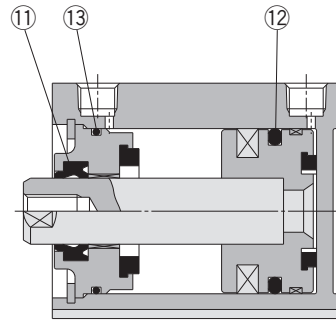

With auto switch

* The numbers are the same as the "Construction" of the CQ2 series catalog (CAT.ES20-205).

Seal Kit List

No.	Description	Material	Note
①	Rod seal	NBR	
②	Piston seal		
③	Tube gasket		

Replacement Parts: Seal Kit

Bore size (mm)	Kit no.	Contents
32	CQ2B32-PS	Set of left nos. ①, ②, ③.
40	CQ2B40-PS	
50	CQ2B50-PS	
63	CQ2B63-PS	
80	CQ2B80-PS	
100	CQ2B100-PS	

* Seal kit includes ①, ②, ③. Order the seal kit, based on each bore size.

* Since the seal kit does not include a grease pack, order it separately.

Grease pack part no.: GR-S-010 (10 g)

Series CBQ2

ø20, ø25, ø32, ø40
ø50, ø63, ø80, ø100

Replacement
Procedure is
P.290

Construction

ø32 to ø63

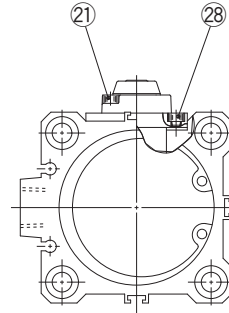
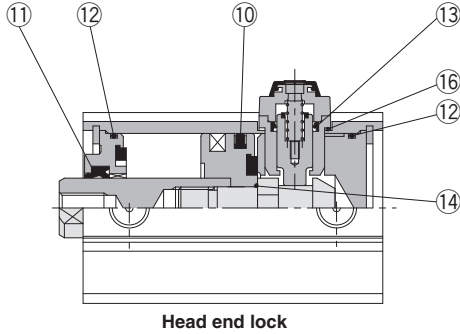

* The numbers are the same as the "Construction" of the CQ2 series catalog (CAT.ES20-205).

Seal Kit List

No.	Description	Material	Note
⑩	Piston seal	NBR	
⑪	Rod seal	NBR	
⑫	Tube gasket	NBR	Using 4 pcs. for ø80, ø100
⑬	Lock piston seal	NBR	
⑭	Piston gasket	NBR	Nothing for ø20, ø25
⑯	Gasket	NBR	
⑰	Hexagon socket head cap screw	Alloy steel	Black zinc chromated
⑱	Hexagon socket head cap screw	Alloy steel	Nickel plated

14 is a non-replaceable part, so it is not included in the seal kit.

Replacement Parts: Seal Kit

Bore size (mm)	Kit no.	Contents
20	CBQ2B20-PS	Set of left nos. ⑩, ⑪, ⑫, ⑬, ⑯, ⑰, ⑱ and a grease pack.
25	CBQ2B25-PS	
32	CBQ2B32-PS	
40	CBQ2B40-PS	
50	CBQ2B50-PS	
63	CBQ2B63-PS	
80	CBQ2B80-PS	
100	CBQ2B100-PS	

* Seal kit includes ⑩, ⑪, ⑫, ⑬, ⑯, ⑰, ⑱. Order the seal kit, based on each bore size.

* Since the seal kit does not include a grease pack, order it separately.
Grease pack part no.: GR-S-010 (10 g)

Actuators

Modular F.R.L.
Pressure Control Equipment

Air Preparation
Equipment

Industrial Filters

Replacement
Procedure

Actuators

Modular F.R.L.
Pressure Control Equipment

Industrial Filters

Series CQ2

ø20, ø25, ø32, ø40
ø50, ø63, ø80, ø100

Replacement
Procedure is
P.290

Construction

Standard (ø40 to ø100)

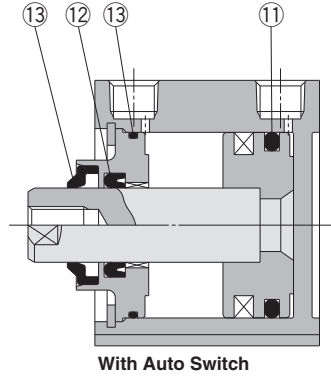
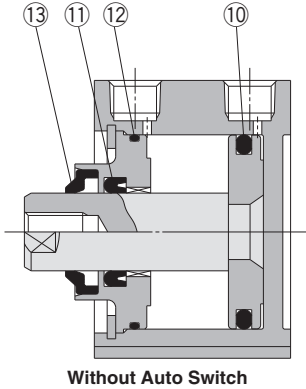

* The numbers are the same as the "Construction" of the CQ2 series catalog (CAT.ES20-205).

Seal Kit List

No.	Description	Material	Note
⑩	Piston seal	R: NBR	
		V: FKM	
⑪	Rod seal	R: NBR	
		V: FKM	
⑫	Tube gasket	R: NBR	
		V: FKM	
13	Rod scraper	R: NBR	
		V: FKM	

* R: NBR seal (Nitrile rubber)
V: FKM seal (Fluororubber)

13 is a non-replaceable part, so it is not included in the seal kit.

Replacement Parts: Seal Kit

Bore size (mm)	Kit no.		Contents
	R: NBR	R: NBR	
20	CQ2B20R-PS	CQ2B20V-PS	Set of left nos. ⑩, ⑪, ⑫.
25	CQ2B25R-PS	CQ2B25V-PS	
32	CQ2B32R-PS	CQ2B32V-PS	
40	CQ2B40R-PS	CQ2B40V-PS	
50	CQ2B50R-PS	CQ2B50V-PS	
63	CQ2B63R-PS	CQ2B63V-PS	
80	CQ2B80R-PS	CQ2B80V-PS	
100	CQ2B100R-PS	CQ2B100V-PS	

* Seal kit includes ⑩, ⑪, ⑫. Order the seal kit, based on each bore size.

* Since the seal kit does not include a grease pack, order it separately.

Grease pack part no.: GR-S-010 (10 g)

Compact Cylinder with Air Cushion

Series RQ

ø20, ø25, ø32, ø40
ø50, ø63, ø80, ø100

Replacement
Procedure is
P.290

Construction

ø20 to ø40

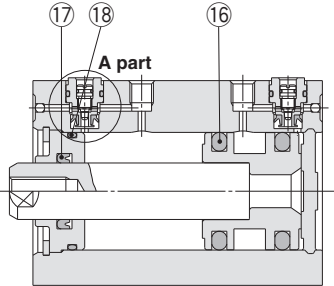

ø50 to ø100

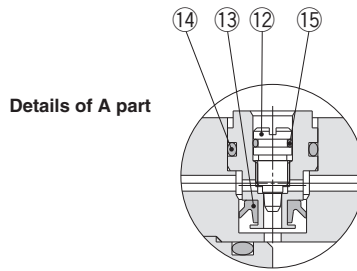
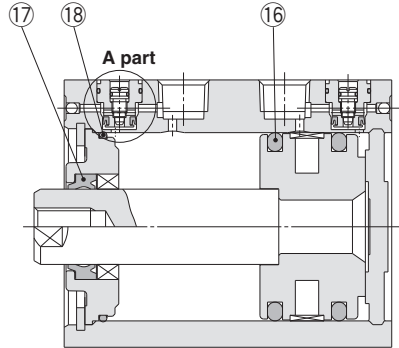

* The numbers are the same as the "Construction" of the Best Pneumatics No.2 Series RQ.

Seal Kit List

No.	Description	Material	Note
12	Cushion needle	Stainless steel	
13	Check seal	NBR	
14	Check gasket	NBR	
15	Needle gasket	NBR	
16	Piston seal	NBR	
17	Rod seal	NBR	
18	Tube gasket	NBR	

12 to 15 are non-replaceable parts, so they are not included in the seal kit.

Replacement Parts: Seal Kit

Bore size (mm)	Kit no.	Contents
20	RQB20-PS	Set of left nos. 16, 17, 18.
25	RQB25-PS	
32	RQB32-PS	
40	RQB40-PS	
50	RQB50-PS	
63	RQB63-PS	
80	RQB80-PS	
100	RQB100-PS	

* Seal kit includes 16, 17, 18. Order the seal kit, based on each bore size.

* Since the seal kit does not include a grease pack, order it separately.

Grease pack part no.: GR-S-010 (10 g)

Actuators

Modular F.R.L.
Pressure Control Equipment

Air Preparation
Equipment

Industrial Filters

Replacement
Procedure

Actuators

Modular F.R.L.
Pressure Control Equipment

Industrial Filters

Compact Cylinder/Plate Type: Double Acting, Single Rod

Series CQU

ø20, ø25, ø32, ø40

Construction

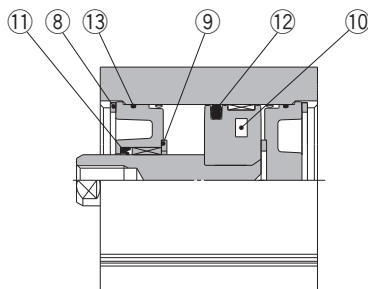

* The numbers are the same as the "Construction" of the CQU series catalog (CAT.ES20-198).

Seal Kit List

No.	Description	Material	Note
⑧	N-type retaining ring	Carbon tool steel	9 and 10 are non-replaceable parts, so they are not included in the seal kit.
9	Bumper	Urethane	
10	Magnet	—	
⑪	Rod seal	NBR	
⑫	Piston seal	NBR	
⑬	O-ring	NBR	

Replacement Parts: Seal Kit

Bore size (mm)	Kit no.	Contents
20	CQUB20-PS	Set of left nos. ⑧, ⑪, ⑫, ⑬.
25	CQUB25-PS	
32	CQUB32-PS	
40	CQUB40-PS	

* Seal kit includes ⑧, ⑪, ⑫, ⑬. Order the seal kit, based on each bore size.

* Since the seal kit does not include a grease pack, order it separately.

Grease pack part no.: GR-S-010 (10 g)

Series MU

ø25, ø32, ø40, ø50, ø63

Construction

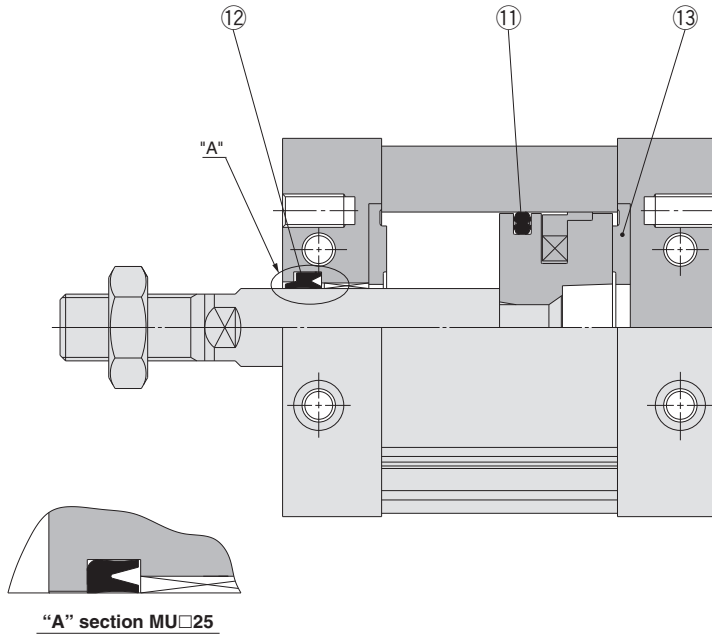

* The numbers are the same as the "Construction" of the MU series catalog (CAT.ES20-208).

Seal Kit List

No.	Description	Material	Note
①	Piston seal	NBR	
②	Rod seal	NBR	
③	Bumper	Urethane	

Replacement Parts: Seal Kit

Bore size (mm)	Kit no.	Contents
25	MUB25-PS	Set of left nos. ①, ②, ③.
32	MUB32-PS	
40	MUB40-PS	
50	MUB50-PS	
63	MUB63-PS	

* Seal kit includes ① to ③. Order the seal kit, based on each bore size.

* Since the seal kit does not include a grease pack, order it separately.

Grease pack part no.: GR-S-010 (10 g)

Actuators

Modular F.R.L.
Pressure Control Equipment

Air Preparation
Equipment

Industrial Filters

Replacement
Procedure

Actuators

Modular F.R.L.
Pressure Control Equipment

Industrial Filters

Series MUW

ø25, ø32, ø40, ø50, ø63

Construction

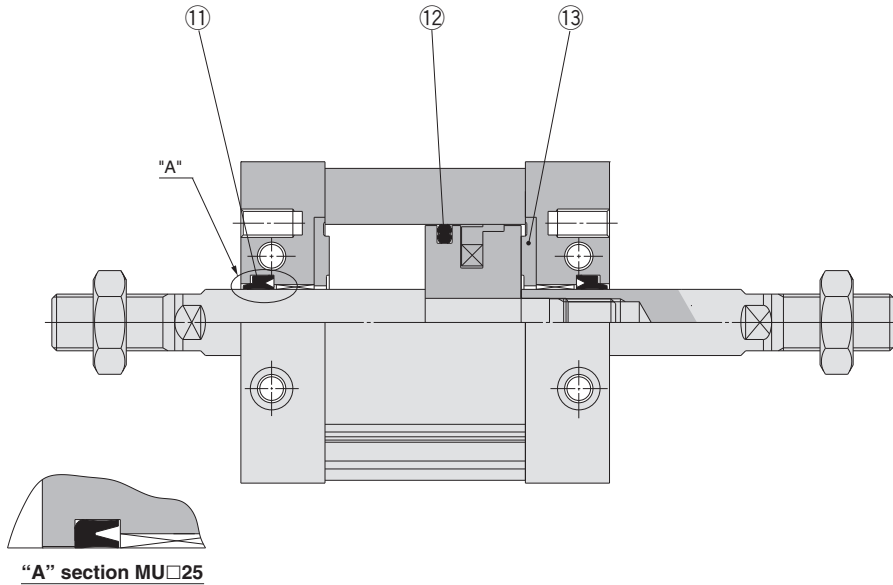

* The numbers are the same as the "Construction" of the MU series catalog (CAT.ES20-208).

Seal Kit List

No.	Description	Material	Note
①	Rod seal	NBR	
②	Piston seal		
③	Bumper		

Replacement Parts: Seal Kit

Bore size (mm)	Kit no.	Contents
25	MUW25-PS	Set of left nos. ①, ②, ③.
32	MUW32-PS	
40	MUW40-PS	
50	MUW50-PS	
63	MUW63-PS	

* Seal kit includes ① to ③. Order the seal kit, based on each bore size.

* Since the seal kit does not include a grease pack, order it separately.

Grease pack part no.: GR-S-010 (10 g)

Series MU

ø25, ø32, ø40, ø50, ø63

Construction

Spring return

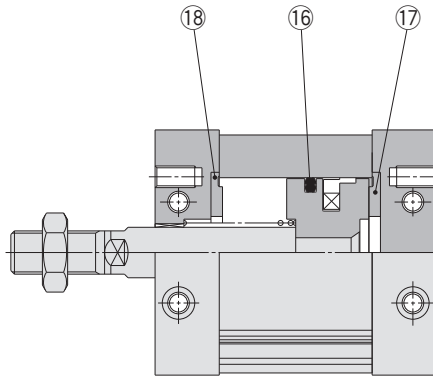

Spring extend

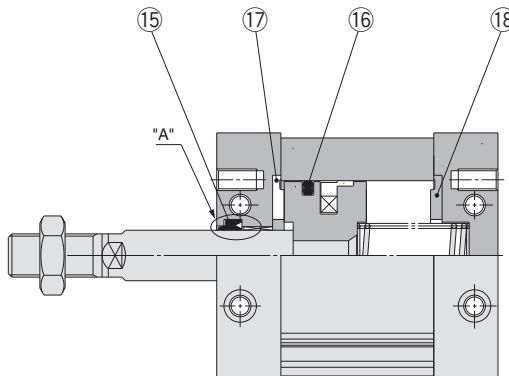

"A" section MU□25

* The numbers are the same as the "Construction" of the MU series catalog (CAT.ES20-208).

Seal Kit List

No.	Description	Material	Note
15	Rod seal	NBR	
16	Piston seal	NBR	
17	Bumper	Urethane	
18	Bumper B	Urethane	

Replacement Parts: Seal Kit

Bore size (mm)	Kit no.		Contents
	Spring return	Spring extend	
25	MU25S-PS	MU25T-PS	For spring return type: 16, 17, 18 as a set
32	MU32S-PS	MU32T-PS	
40	MU40S-PS	MU40T-PS	For spring extend type: 15, 16, 17, 18 as a set
50	MU50S-PS	MU50T-PS	
63	MU63S-PS	MU63T-PS	

* Seal kit includes 15, 16, 17, 18 (excluding 15 for spring return type).
Order them with a part number for each bore size.

* Since the seal kit does not include a grease pack, order it separately.

Grease pack part no.: GR-S-010 (10 g)

Actuators

Modular F.R.L.
Pressure Control Equipment

Air Preparation
Equipment

Industrial Filters

Replacement
Procedure

Actuators

Modular F.R.L.
Pressure Control Equipment

Industrial Filters

Series CG5-S

ø20, ø25, ø32
ø40, ø50, ø63
ø80, ø100



Construction

With rubber bumper

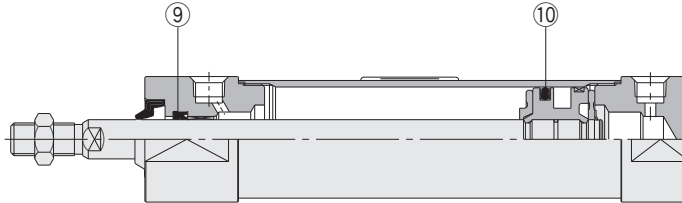

With air cushion

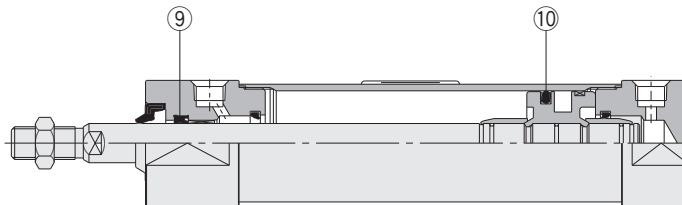
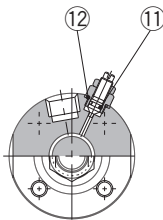

* The numbers are the same as the "Construction" of the Best Pneumatics No.2 Series CG5-S.

Seal Kit List

No.	Description	Material	
		CG5□□□SR	CG5□□□SV
⑨	Rod seal	NBR	FKM
⑩	Piston seal		
⑪	Valve seal		
⑫	Valve retainer gasket		

Replacement Parts: Seal Kit

Bore size (mm)	Kit no.		Contents
	CG5□N□SR	CG5□N□SV	

Rubber bumper

20	CG5N20SR-PS	CG5N20SV-PS	Set of left nos. ⑨, ⑩.
25	CG5N25SR-PS	CG5N25SV-PS	
32	CG5N32SR-PS	CG5N32SV-PS	
40	CG5N40SR-PS	CG5N40SV-PS	

Bore size (mm)	Kit no.		Contents
	CG5□A□SR	CG5□A□SV	

Air cushion

20	CG5A20SR-PS	CG5A20SV-PS	Set of left nos. ⑨, ⑩, ⑪, ⑫.
25	CG5A25SR-PS	CG5A25SV-PS	
32	CG5A32SR-PS	CG5A32SV-PS	
40	CG5A40SR-PS	CG5A40SV-PS	

* Seal kit includes a grease pack (10 g).

Order with the following part number when only the grease pack is needed.

Grease pack part no.: GR-R-010 (10 g)

⚠ Caution

When disassembling cylinders with bore sizes of ø20 through ø40, grip the double flat part of either the tube cover or the rod cover with a vise and loosen the other side with a wrench or a monkey wrench, etc., and then remove the cover. When retightening, tighten approximately 2 degrees more than the original position. (Cylinders with ø50 or larger bore sizes are tightened with a large tightening torque and cannot be disassembled.)

Series HYQ

ø20, ø25, ø32
ø40, ø50, ø63



Construction

ø20, ø25

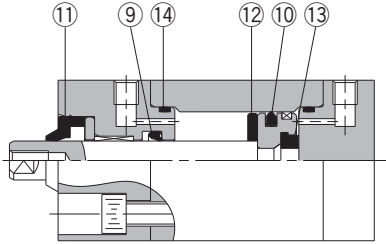

ø32 to ø63

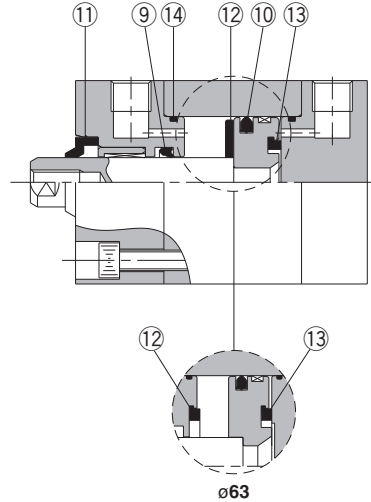

* The numbers are the same as the "Construction" of the Best Pneumatics No.2 Series HYQ.

Seal Kit List

No.	Description	Material	Note
⑨	Rod seal	NBR	(FKM can be selected.)
⑩	Piston seal	NBR	
⑪	Rod scraper	NBR	(FKM can be selected.)
⑫	Bumper A	Resin	
⑬	Bumper B	Resin	
⑭	Tube gasket	NBR	(FKM can be selected.)

11, 12 and 13 are non-replaceable parts, so they are not included in the seal kit.

Replacement Parts: Seal Kit

Bore size (mm)	Kit no.	Contents
20	HYQB20□-PS	Set of nos. above ⑨, ⑩, ⑭.
25	HYQB25□-PS	

Place the seal material symbol in □.

Symbol	Material
R	NBR
H	External FKM*

- * External seal: Rod seal and the tube gasket are made from FKM.
- * Seal kit includes ⑨, ⑩ and ⑭. Order the seal kit based on each bore size.
- * Since the seal kit does not include a grease pack, order it separately.
Grease for food part no.: GR-H-010 (10 g)
Standard grease part no.: GR-S-010 (10 g)

Seal Kit List

No.	Description	Material	Note
⑨	Rod seal	NBR	(FKM can be selected.)
⑩	Piston seal	NBR	
⑪	Rod scraper	NBR	(FKM can be selected.)
⑫	Bumper A	Resin	
⑬	Bumper B	Resin	(Only ø63 is common to the bumper A.)
⑭	Tube gasket	NBR	(FKM can be selected.)

11, 12 and 13 are non-replaceable parts, so they are not included in the seal kit.

Replacement Parts: Seal Kit

Bore size (mm)	Kit no.	Contents
32	HYQB32□-PS	Set of nos. above ⑨, ⑩, ⑭.
40	HYQB40□-PS	
50	HYQB50□-PS	
63	HYQB63□-PS	

Place the seal material symbol in □.

Symbol	Material
R	NBR
H	External FKM*

- * External seal: Rod seal and the tube gasket are made from FKM.
- * Seal kit includes ⑨, ⑩ and ⑭. Order the seal kit based on each bore size.
- * Since the seal kit does not include a grease pack, order it separately.
Grease for food part no.: GR-H-010 (10 g)
Standard grease part no.: GR-S-010 (10 g)

Actuators

Modular F.R.L.
Pressure Control Equipment

Air Preparation
Equipment

Industrial Filters

Replacement
Procedure

Actuators

Modular F.R.L.
Pressure Control Equipment

Industrial Filters

Series *HYC*

ø32, ø40, ø50, ø63



Construction

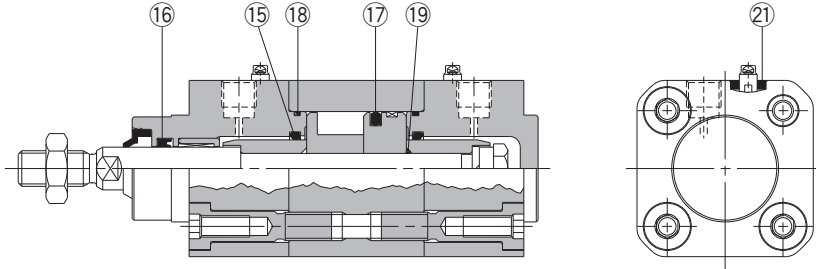

* The numbers are the same as the "Construction" of the Best Pneumatics No.2 Series HYC.

Seal Kit List

No.	Description	Material	Qty.	Note
15	Cushion seal	Resin	2	
16	Rod seal	NBR	1	(FKM can be selected.)
17	Piston seal	NBR	1	
18	Cylinder tube gasket	NBR	2	(FKM can be selected.)
19	Piston gasket	NBR	1	
21	Needle scraper	NBR	2	(FKM can be selected.)

19 is a non-replaceable part, so it is not included in the seal kit.

Replacement Parts: Seal Kit

Bore size (mm)	Kit no.	Contents
32	HYCB32□-PS	Set of left nos. 15, 16, 17, 18, 21.
40	HYCB40□-PS	
50	HYCB50□-PS	
63	HYCB63□-PS	

Place the seal material symbol in □.

Symbol	Material
R	NBR
H	External FKM*

- * External seal: Rod seal, the tube gasket and needle scraper are made from FKM.
- * Seal kit includes 15, 16, 17, 18 and 21. Order the seal kit based on each bore size.
- * Since the seal kit does not include a grease pack, order it separately.
Grease for food part no.: GR-H-010 (10 g)
Standard grease part no.: GR-S-010 (10 g)

Construction

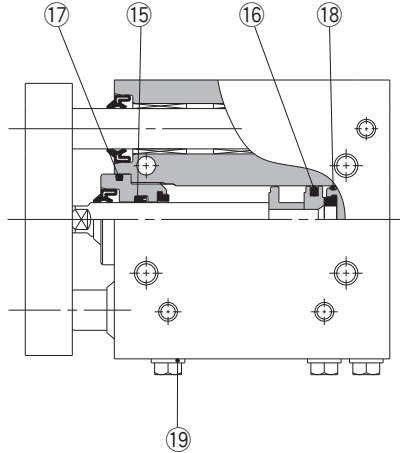

* The numbers are the same as the "Construction" of the Best Pneumatics No.2 Series HYG.

Seal Kit List

No.	Description	Material	Note
15	Rod seal	NBR	(FKM can be selected.)
16	Piston seal	NBR	
17	O-ring (Rod end)	NBR	(FKM can be selected.)
18	O-ring (Head end)	NBR	
19	Seal washer	Stainless steel + NBR	(FKM can be selected.)

18 is a non-replaceable part, so it is not included in the seal kit.

Replacement Parts: Seal Kit

Bore size (mm)	Kit no.	Contents
20	HYG20□-PS	Set of left nos. 15, 16, 17, 19.
25	HYG25□-PS	
32	HYG32□-PS	

Place the seal material symbol in □.

Symbol	Material
R	NBR
H	External FKM*

* External seal: Rod seal, O-ring (Rod side) and seal washer are made from FKM.

* Seal kit includes 15, 16, 17 and 19. Order the seal kit based on each bore size.

* Since the seal kit does not include a grease pack, order it separately.

Grease for food part no.: GR-H-010 (10 g)

Standard grease part no.: GR-S-010 (10 g)

⚠ Caution

Please contact SMC to repair or replace seals of cylinder bore size 40 mm and above.

Please contact SMC when the cylinder has to be disassembled for the purpose of replacing seals, etc.

Series MY1B $\phi 10$

Replacement
Procedure is
p.304

Construction

Centralized piping type: $\phi 10$

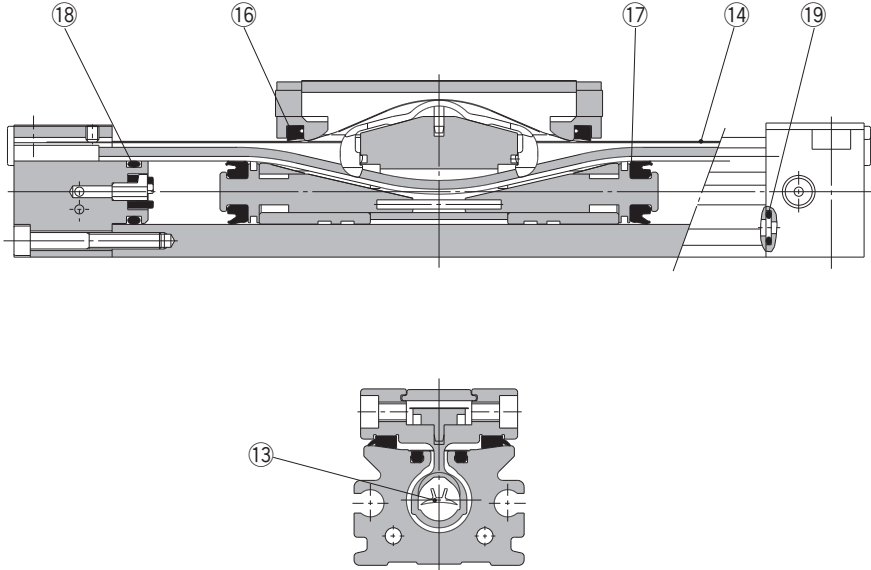

* The numbers are the same as the "Construction" of the Best Pneumatics No.2 Series MY1B.

Replacement Parts: Seal Kit

No.	Description	Qty.	MY1B10	Note
13	Seal belt	1	MY10-16A-Stroke	13 and 14 are not included in the seal kit. Order them as required with by individual part numbers.
14	Dust seal band	1	MY10-16B-Stroke	
16	Scraper	2	MY1B10-PS	
17	Piston seal	2		
18	Tube gasket	2		
19	O-ring	4		

* Seal kit includes 16, 17, 18 and 19.

Seal kit includes a grease pack (10 g).

When 13 and 14 are shipped independently, a grease pack is included. (10 g per 1000 strokes)

Order with the following part number when only the grease pack is needed.

Grease pack part no.: GR-S-010 (10 g), GR-S-020 (20 g)

Series MY1B

ø16, ø20, ø25, ø32
ø40, ø50, ø63, ø80
ø100

Replacement
Procedure is
P.304

Construction

ø16 to ø100

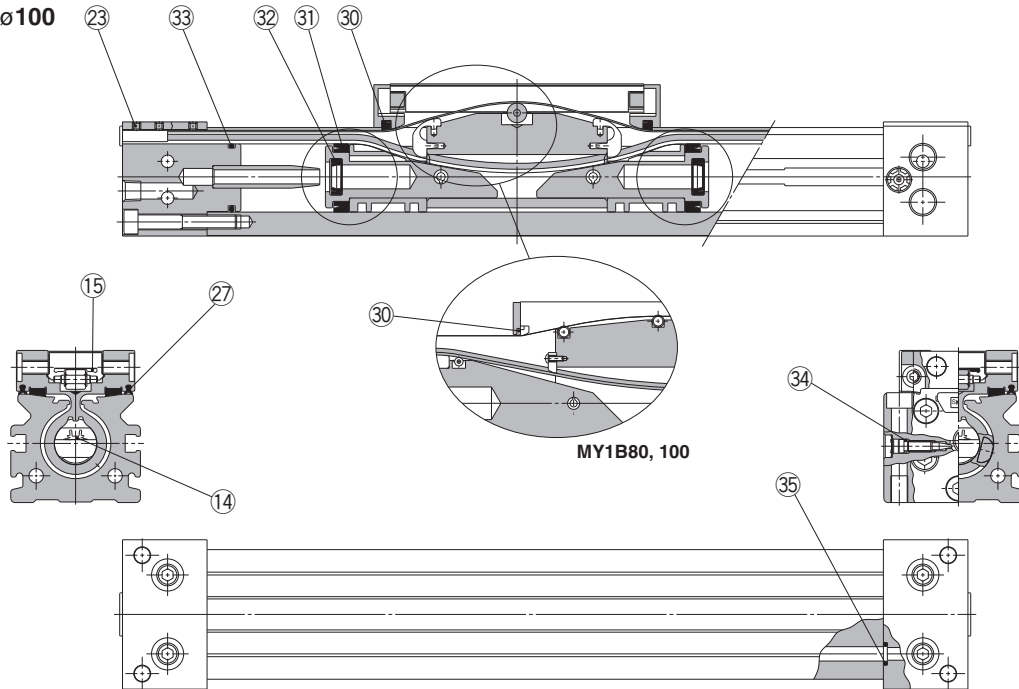

* The numbers are the same as the "Construction" of the Best Pneumatics No.2 Series MY1B.

Replacement Parts: Seal Kit

No.	Description	Qty.	MY1B16	MY1B20	MY1B25	MY1B32	MY1B40
14	Seal belt	1	MY16-16A-Stroke	MY20-16A-Stroke	MY25-16A-Stroke	MY32-16A-Stroke	MY40-16A-Stroke
15	Dust seal band	1	MY16-16B-Stroke	MY20-16B-Stroke	MY25-16B-Stroke	MY32-16B-Stroke	MY40-16B-Stroke
27	Side scraper	2	—	MYB20-15CA7164B	MYB25-15BA5900B	MYB32-15BA5901B	MYB40-15BA5902B
34	O-ring	2	KA00309 (ø4 x ø1.8 x ø1.1)	KA00309 (ø4 x ø1.8 x ø1.1)	KA00311 (ø5.1 x ø3 x ø1.05)	KA00320 (ø7.15 x ø3.75 x ø1.7)	KA00320 (ø7.15 x ø3.75 x ø1.7)
30	Scraper	2					
31	Piston seal	2					
32	Cushion seal	2	MY1B16-PS	MY1B20-PS	MY1B25-PS	MY1B32-PS	MY1B40-PS
33	Tube gasket	2					
35	O-ring	4					

No.	Description	Qty.	MY1B50	MY1B63	MY1B80	MY1B100	Note
14	Seal belt	1	MY50-16A-Stroke	MY63-16A-Stroke	MY80-16A-Stroke	MY100-16A-Stroke	14, 15, 27 and 34 are not included in the seal kit. Order them as required with by individual part numbers.
15	Dust seal band	1	MY50-16B-Stroke	MY63-16B-Stroke	MY80-16B-Stroke	MY100-16B-Stroke	
27	Side scraper	2	MYB50-15CA7165B	MYB63-15CA7166B	MYB80-15CK2470B	MY100-15CK2471B	
34	O-ring	2	KA00402 (ø8.3 x ø4.5 x ø1.9)	KA00777 —	KA00050 —	KA00050 —	
30	Scraper	2					
31	Piston seal	2					
32	Cushion seal	2	MY1B50-PS	MY1B63-PS	MY1B80-PS	MY1B100-PS	
33	Tube gasket	2					
35	O-ring	4					

* Seal kit includes 30, 31, 32, 33 and 35. Order the seal kit based on each bore size.

* Seal kit includes a grease pack (10 g).

When 14 and 15 are shipped independently, a grease pack is included. (10 g per 1000 strokes)

Order with the following part number when only the grease pack is needed.

Grease pack part no.: GR-S-010 (10 g), GR-S-020 (20 g)

Note) Two kinds of dust seal bands are available. Verify the type to use, since the part number varies depending on the treatment of the hexagon socket head set screw 23.

A: Black zinc chromated → MY□□-16B-stroke, B: Nickel plated → MY□□-16BW-stroke

Mechanically Jointed Rodless Cylinder/Basic Type

Series MY1B-□Z

ø25, ø32, ø40

Construction

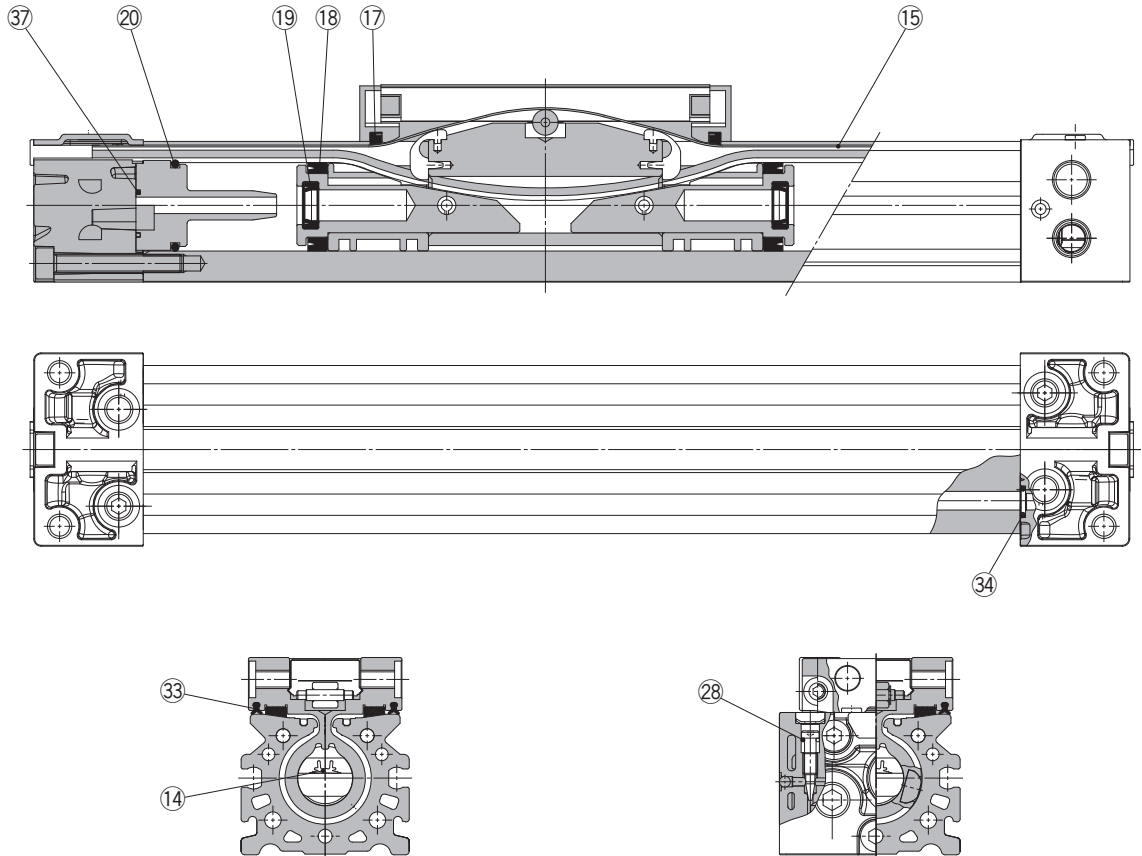

* The numbers are the same as the "Construction" of the MY1B series catalog (CAT.ES20-210).

Seal Kit List

No.	Description	Material	Qty.	MY1B25	MY1B32	MY1B40	Note
14	Seal belt	Urethane Polyamide	1	MY25-16C-Stroke	MY32-16C-Stroke	MY40-16A-Stroke	14, 15, 28, 33 and 37 are not included in the seal kit. Order them as required with by individual part numbers.
15	Dust seal band	Stainless steel	1	MY1B25-16B-Stroke	MY1B32-16B-Stroke	MY1B40-16B-Stroke	
28	O-ring	NBR	2	KA00311 (ø5.1 x ø3 x ø1.05)	KA00320 (ø7.15 x ø3.75 x ø1.7)	KA00320 (ø7.15 x ø3.75 x ø1.7)	
33	Side scraper	Polyamide	2	MYB25-15BA5900B	MYB32-15BA5901B	MYB40-15BA5902B	
37	Cushion boss gasket	NBR	2	MYB25-16GA5900	MYB32-16GA5901	MYB40-16GA5902	
17	Scraper	NBR	2	MY1B25-PS	MY1B32-PS	MY1B40-PS	
18	Piston seal	NBR	2				
19	Cushion seal	NBR	2				
20	Tube gasket	NBR	2				
34	O-ring	NBR	2				

* Seal kit includes 17, 18, 19, 20 and 34. Order the seal kit based on each bore size.

* Seal kit includes a grease pack (10 g).

When 14 and 15 are shipped independently, a grease pack is included. (10 g/1000 mm stroke)

Order with the following part number when only the grease pack is needed.

Grease pack part no.: GR-S-010 (10 g), GR-S-020 (20 g)

Note) For the replacement procedure of replacement parts/seals, refer to the Operation Manual.

Mechanically Jointed Rodless Cylinder/Linear Guide Type

Series MY1H-□Z

ø25, ø32, ø40

Construction

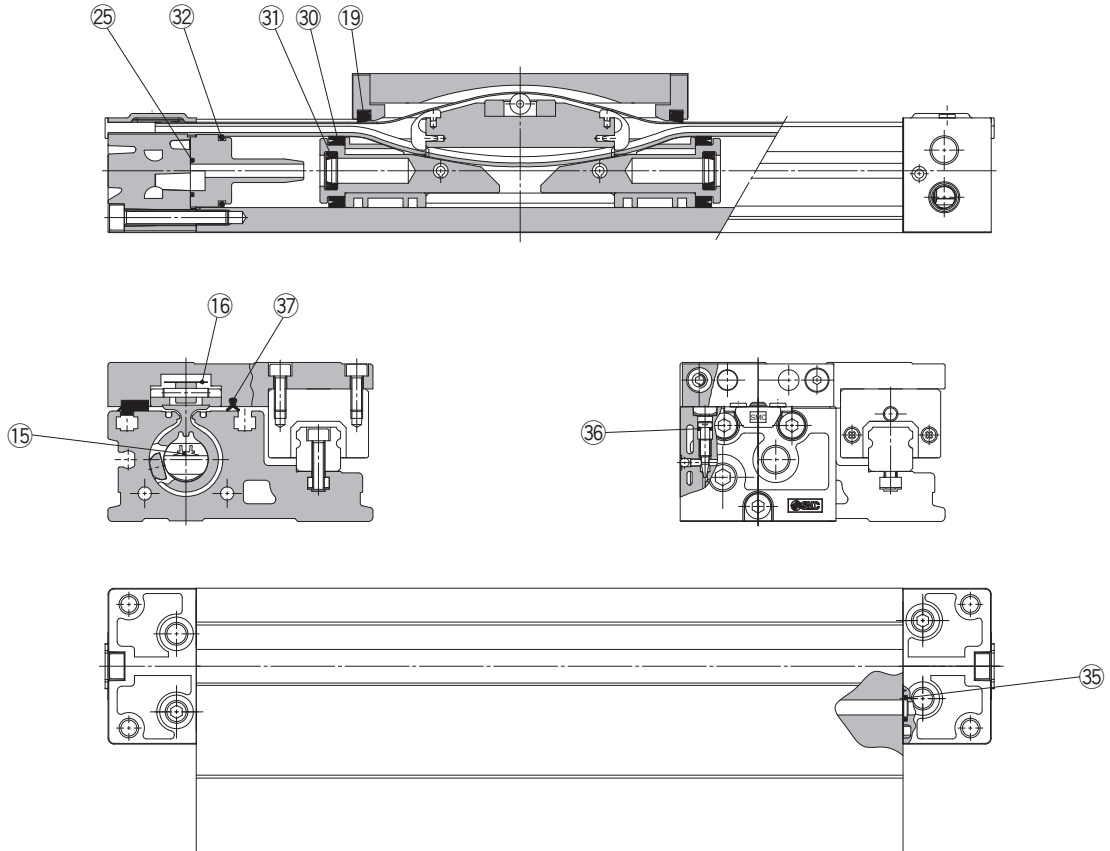

* The numbers are the same as the "Construction" of the MY1H series catalog (CAT.ES20-221).

Replacement Parts: Seal Kit (15, 16, 25, 36 and 37 are not included in the seal kit. Order them as required with by individual part numbers.)

No.	Description	Material	Qty.	MY1H25	MY1H32	MY1B40
15	Seal belt	Urethane/Polyamide	1	MY25-16C- [Stroke]	MY32-16C- [Stroke]	MY40-16A- [Stroke]
16	Dust seal band	Stainless steel	1	MY1B25-16B- [Stroke]	MY1B32-16B- [Stroke]	MY1B40-16B- [Stroke]
25	Cushion boss gasket	NBR	2	MYB25-16GA5900	MYB32-16GA5901	MYB40-16GA5902
36	O-ring	NBR	2	KA00311 (ø5.1 x ø3 x ø1.05)	KA00320 (ø7.15 x ø3.75 x ø1.7)	KA00320 ø7.15 x ø3.75 x ø1.7
37	Side scraper	Special resin	2	MYH25-15BK2902B	MYH32-15BK2903B	MYH40-15BK2904B
19	Scraper	NBR	2	MY1H25-PS	MY1H32-PS	MY1H40-PS
30	Piston seal	NBR	2			
31	Cushion seal	NBR	2			
32	Tube gasket	NBR	2			
35	O-ring	NBR	2			

* Seal kit includes 19, 30, 31, 32 and 35. Order the seal kit based on each bore size.

* Seal kit includes a grease pack (10 g).

When 15 and 16 are shipped independently, a grease pack is included. (10 g/1000 mm stroke)

Order with the following part number when only the grease pack is needed.

Grease pack part no.: GR-S-010 (10 g), GR-S-020 (20 g)

Series MY1H-Z ø25, ø32, ø40

Construction

With End Lock: ø25 to ø40

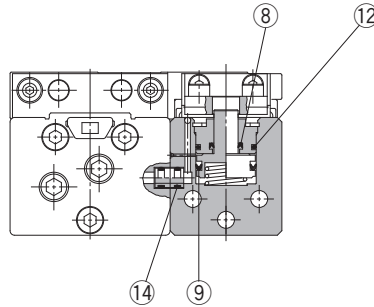

* The numbers are the same as the "Construction" of the MY1H series catalog (CAT.ES20-221).

Replacement Parts: Seal Kit

No.	Description	Material	Qty.	MY1H25	MY1H32	MY1H40
8	Rod seal	NBR	1	KB00267	KB00267	KB00267
9	Piston seal	NBR	1	KB00217	KB00217	KB00217
12	O-ring	NBR	1	KA00037	KA00037	KA00037
14	O-ring	NBR	2	KA00048	KA00048	KA00048

* Since the seal kit does not include a grease pack, order it separately.

Grease pack part no.: GR-S-010 (10 g)

Series MY1M

ø16, ø20, ø25, ø32
ø40, ø50, ø63

Replacement
Procedure is
P.306

Construction

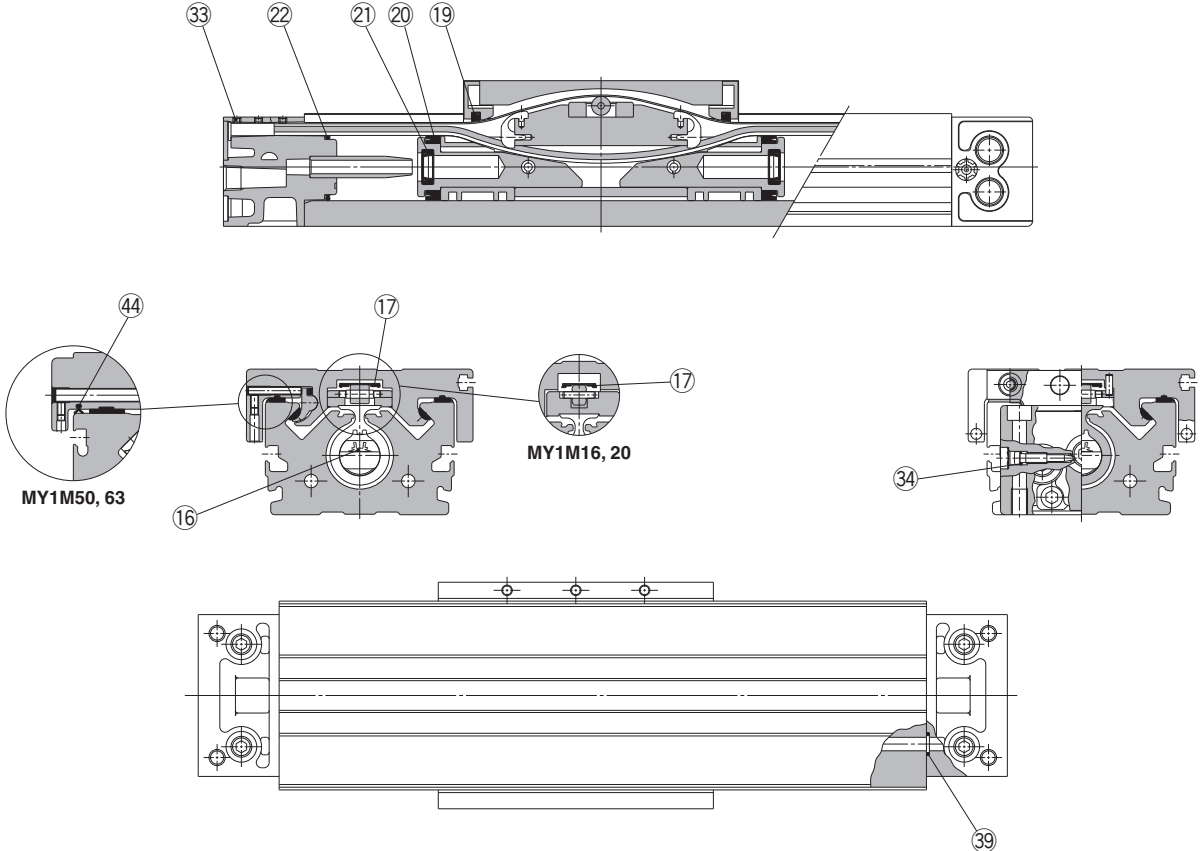

* The numbers are the same as the "Construction" of the Best Pneumatics No.2 Series MY1M.

Seal Kit List (16, 17, 34 and 44 are not included in the seal kit. Order them as required with by individual part numbers.)

No.	Description	Qty.	MY1M16	MY1M20	MY1M25	MY1M32	MY1M40	MY1M50	MY1M63
16	Seal belt	1	MY16-16A-Stroke	MY20-16A-Stroke	MY25-16A-Stroke	MY32-16A-Stroke	MY40-16A-Stroke	MY50-16A-Stroke	MY63-16A-Stroke
17	Dust seal band	1	MY16-16B-Stroke	MY20-16B-Stroke	MY25-16B-Stroke	MY32-16B-Stroke	MY40-16B-Stroke	MY50-16B-Stroke	MY63-16B-Stroke
34	O-ring	2	KA00309 (ø4 x ø1.8 x ø1.1)	KA00311 (ø5.1 x ø3 x ø1.05)	KA00311 (ø5.1 x ø3 x ø1.05)	KA00320 (ø7.15 x ø3.75 x ø1.7)	KA00402 (ø8.3 x ø4.5 x ø1.9)	KA00777	KA00777
44	Side scraper	2	—	—	—	—	—	MYM50-15CK0502B	MYM63-15CK0503B
19	Scraper	2							
20	Piston seal	2							
21	Cushion seal	2	MY1M16-PS	MY1M20-PS	MY1M25-PS	MY1M32-PS	MY1M40-PS	MY1M50-PS	MY1M63-PS
22	Tube gasket	2							
39	O-ring	4							

* Seal kit includes 19, 20, 21, 22 and 39. Order the seal kit based on each bore size.

* Seal kit includes a grease pack (10 g).

When 16 and 17 are shipped independently, a grease pack is included. (10 g per 1000 strokes)

Order with the following part number when only the grease pack is needed.

Grease pack part no.: GR-S-010 (10 g), GR-S-020 (20 g)

Note) Two kinds of dust seal bands are available. Verify the type to use, since the part number varies depending on the treatment of the hexagon socket head set screw 39.

A: Black zinc chromated → MY□□-16B-stroke, B: Nickel plated → MY□□-16BW-stroke

Series MY1C

ø16, ø20, ø25, ø32
ø40, ø50, ø63

Replacement
Procedure is
P.306

Construction

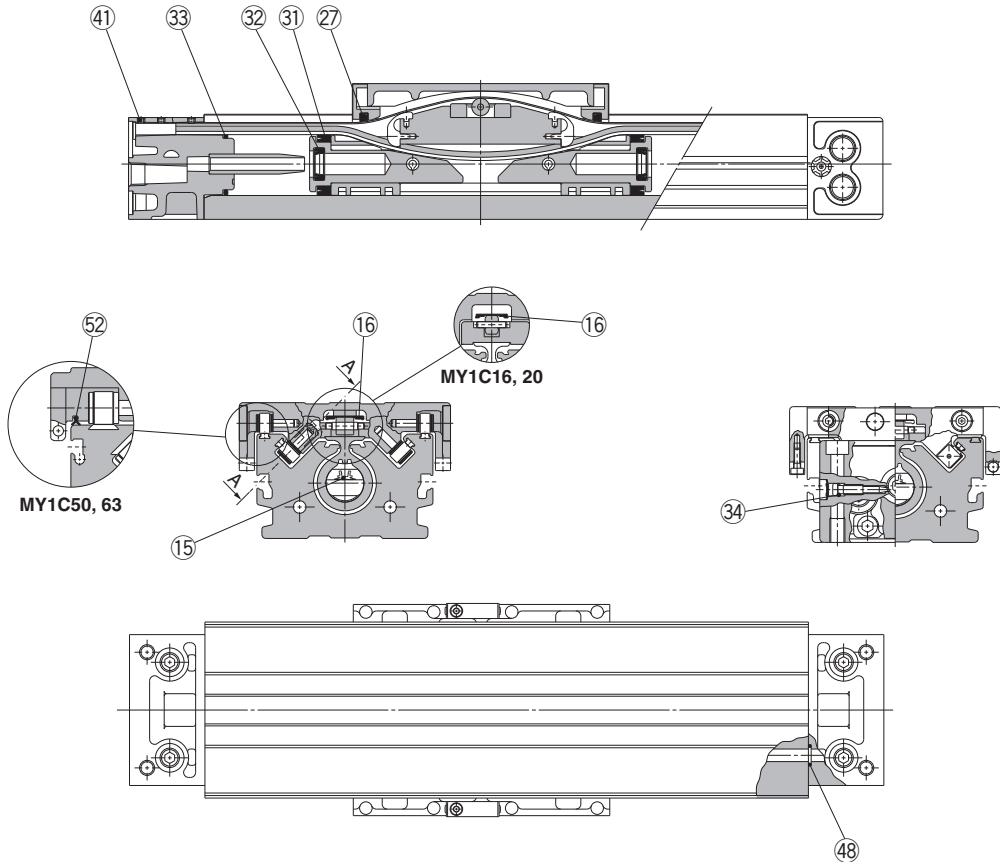

* The numbers are the same as the "Construction" of the Best Pneumatics No.2 Series MY1C.

Seal Kit List (15, 16, 34 and 52 are not included in the seal kit. Order them as required with by individual part numbers.)

No.	Description	Qty.	MY1C16	MY1C20	MY1C25	MY1C32	MY1C40	MY1C50	MY1C63
15	Seal belt	1	MY16-16A-Stroke	MY20-16A-Stroke	MY25-16A-Stroke	MY32-16A-Stroke	MY40-16A-Stroke	MY50-16A-Stroke	MY63-16A-Stroke
16	Dust seal band	1	MY16-16B-Stroke	MY20-16B-Stroke	MY25-16B-Stroke	MY32-16B-Stroke	MY40-16B-Stroke	MY50-16B-Stroke	MY63-16B-Stroke
34	O-ring	2	KA00309 (ø4 x ø1.8 x ø1.1)	KA00311 (ø5.1 x ø3 x ø1.05)	KA00311 (ø5.1 x ø3 x ø1.05)	KA00320 (ø7.15 x ø3.75 x ø1.7)	KA00402 (ø8.3 x ø4.5 x ø1.9)	KA00777	KA00777
52	Side scraper	2	—	—	—	—	—	MYM50-15CK0502B	MYM63-15CK0503B
27	Scraper	2							
31	Piston seal	2							
32	Cushion seal	2	MY1M16-PS	MY1M20-PS	MY1M25-PS	MY1M32-PS	MY1M40-PS	MY1M50-PS	MY1M63-PS
33	Tube gasket	2							
48	O-ring	4							

* Seal kit includes 27, 31, 32, 33 and 48. Order the seal kit based on each bore size.

* Seal kit includes a grease pack (10 g).

When 15 and 16 are shipped independently, a grease pack is included. (10 g per 1000 strokes)

Order with the following part number when only the grease pack is needed.

Grease pack part no.: GR-S-010 (10 g), GR-S-020 (20 g)

Note) Two kinds of dust seal bands are available. Verify the type to use, since the part number varies depending on the treatment of the hexagon socket head set screw 41.

A: Black zinc chromated → MY□□-16B-stroke, B: Nickel plated → MY□□-16BW-stroke

Mechanically Jointed Rodless Cylinder/Linear Guide Type

Series MY1H $\phi 10$

Replacement
Procedure is
P.310

Construction

Centralized piping type: $\phi 10$

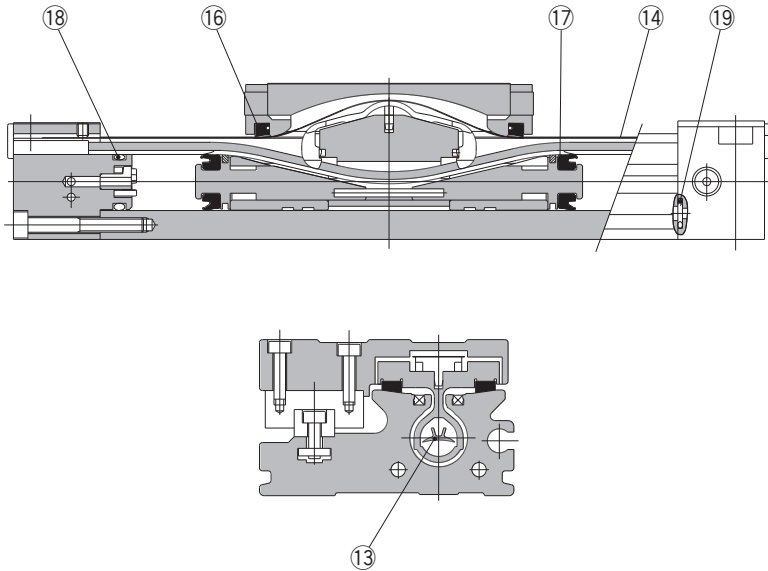

* The numbers are the same as the "Construction" of the Best Pneumatics No.2 Series MY1H.

Replacement Parts: Seal Kit

No.	Description	Qty.	MY1H10	Note
13	Seal belt	1	MY10-16A-Stroke	13 and 14 are not included in the seal kit. Order them as required with by individual part numbers.
14	Dust seal band	1	MY10-16B-Stroke	
16	Scraper	2	MY1B10-PS	
17	Piston seal	2		
18	Tube gasket	2		
19	O-ring	4		

* Seal kit includes 16, 17, 18 and 19.

Seal kit includes a grease pack (10 g).

When 13 and 14 are shipped independently, a grease pack is included.

Order with the following part number when only the grease pack is needed.

Grease pack part no.: GR-S-010 (10 g), GR-S-020 (20 g)

Actuators

Modular F.R.L.
Pressure Control Equipment

Air Preparation
Equipment

Industrial Filters

Replacement
Procedure

Actuators

Modular F.R.L.
Pressure Control Equipment

Industrial Filters

Mechanically Jointed Rodless Cylinder/Linear Guide Type

Series MY1H

ø16, ø20, ø25
ø32, ø40

Replacement
Procedure is
P.310

Construction

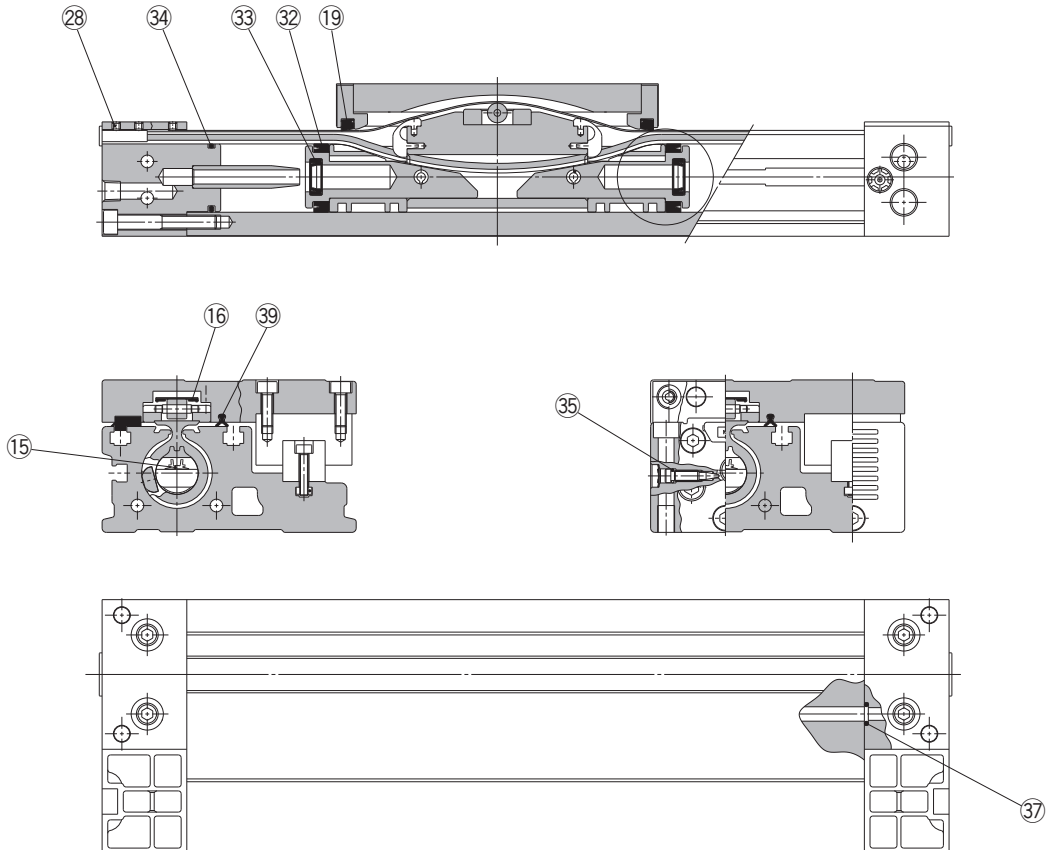

* The numbers are the same as the "Construction" of the Best Pneumatics No.2 Series MY1H.

Replacement Parts: Seal Kit (15, 16, 35 and 39 are not included in the seal kit. Order them as required with by individual part numbers.)

No.	Description	Qty.	MY1H16	MY1H20	MY1H25	MY1H32	MY1H40
15	Seal belt	1	MY16-16A-[Stroke]	MY20-16A-[Stroke]	MY25-16A-[Stroke]	MY32-16A-[Stroke]	MY40-16A-[Stroke]
16	Dust seal band	1	MY16-16B-[Stroke]	MY20-16B-[Stroke]	MY25-16B-[Stroke]	MY32-16B-[Stroke]	MY40-16B-[Stroke]
35	O-ring	2	KA00309 (ø4 x ø1.8 x ø1.1)	KA00309 (ø4 x ø1.8 x ø1.1)	KA00311 (ø5.1 x ø3 x ø1.05)	KA00320 (ø7.15 x ø3.75 x ø1.7)	KA00320 (ø7.15 x ø3.75 x ø1.7)
39	Side scraper	1	MYH16-15BK2900B	MYH20-15BK2901B	MYH25-15BK2902B	MYH32-15BK2903B	MYH40-15BK2904B
19	Scraper	2					
32	Piston seal	2					
33	Cushion seal	2	MY1H16-PS	MY1H20-PS	MY1H25-PS	MY1H32-PS	MY1H40-PS
34	Tube gasket	2					
37	O-ring	4					

* Seal kit includes 19, 32, 33, 34 and 37. Order the seal kit based on each bore size.

* Seal kit includes a grease pack (10 g).

When 15 and 16 are shipped independently, a grease pack (20 g) is included.

Order with the following part number when only the grease pack is needed.

Grease pack part no.: GR-S-010 (10 g), GR-S-020 (20 g)

Note) Two kinds of dust seal bands are available. Verify the type to use, since the part number varies depending on the treatment of the hexagon socket head set screw 28.

A: Black zinc chromated → MY□□-16B-stroke, B: Nickel plated → MY□□-16BW-stroke

Mechanically Jointed Rodless Cylinder/Linear Guide Type

Series MY1H

ø16, ø20, ø25
ø32, ø40

Replacement
Procedure is
P.310

Construction

With End Lock: ø16 to ø40

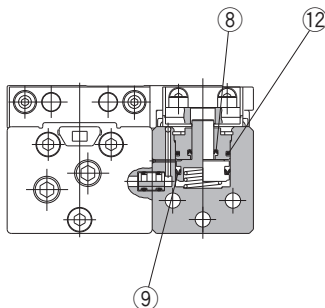

* The numbers are the same as the "Construction" of the Best Pneumatics No.2 Series MY1H.

Replacement Parts: Seal

No.	Description	Material	Qty.	MY1H16	MY1H20	MY1H25	MY1H32	MY1H40
8	Rod seal	NBR	1	KB00257	KB00257	KB00267	KB00267	KB00267
9	Piston seal		1	KB00202	KB00202	KB00217	KB00217	KB00217
12	O-ring		1	KA00057	KA00057	KA00037	KA00037	KA00037

* Since the seal kit does not include a grease pack, order it separately.

Grease pack part no.: GR-S-010 (10 g)

Actuators

Modular F.R.L.
Pressure Control Equipment

Air Preparation
Equipment

Industrial Filters

Replacement
Procedure

Actuators

Modular F.R.L.
Pressure Control Equipment

Industrial Filters

Series MY1□W

ø16, ø20, ø25
ø32, ø40, ø50
ø63

Replacement
Procedure is
P.306

Construction

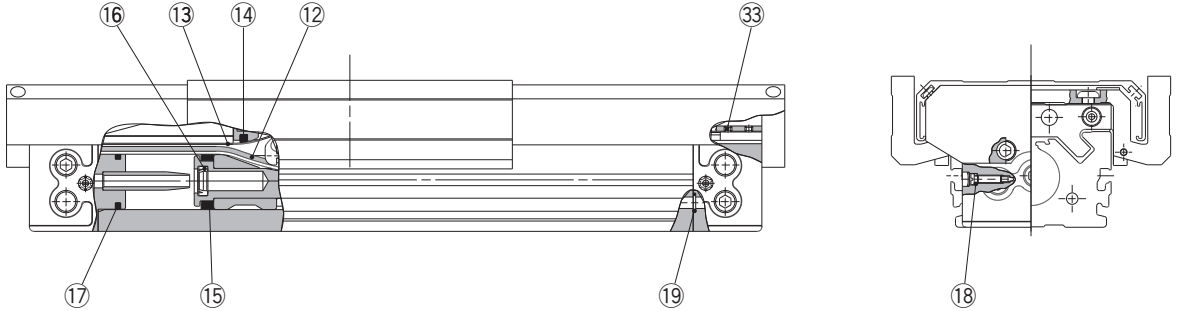

With side seal

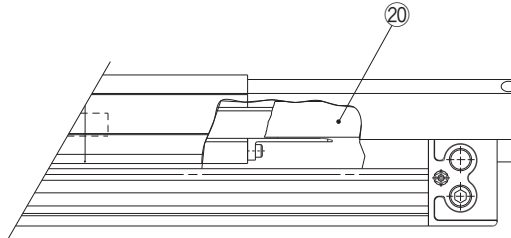

* The numbers are the same as the "Construction" of the Best Pneumatics No.2 Series MY1□W.

Seal Kit List (12, 13, 18 and 20 are not included in the seal kit. Order them as required with by individual part numbers.)

No.	Description	Qty.	ø16	ø20	ø25	ø32	ø40	ø50	ø63
12	Seal belt	1	MY16-16A-Stroke	MY20-16A-Stroke	MY25-16A-Stroke	MY32-16A-Stroke	MY40-16A-Stroke	MY50-16A-Stroke	MY63-16A-Stroke
13	Dust seal band ^(Note)	1	MY16-16B-Stroke	MY20-16B-Stroke	MY25-16B-Stroke	MY32-16B-Stroke	MY40-16B-Stroke	MY50-16B-Stroke	MY63-16B-Stroke
18	O-ring	2	KA00309 (ø4 x ø1.8 x ø1.1)	KA00311 (ø5.1 x ø3 x ø1.05)	KA00311 (ø5.1 x ø3 x ø1.05)	KA00320 (ø7.15 x ø3.75 x ø1.7)	KA00402 (ø8.3 x ø4.5 x ø1.9)	KA00777	KA00777
20	Side seal assembly	2	MYMK-16-Stroke	MYMK-20-Stroke	MYMK-25-Stroke	MYMK-32-Stroke	MYMK-40-Stroke		
14	Scraper	2							
15	Piston seal	2							
16	Cushion seal	2	MY1M16-PS	MY1M20-PS	MY1M25-PS	MY1M32-PS	MY1M40-PS	MY1M50-PS	MY1M63-PS
17	Tube gasket	2							
19	O-ring	4							

Note) Two kinds of dust seal bands are available. Verify the type to use, since the part number varies depending on the treatment of the hexagon socket head set screw 33 (Refer to the Construction of MY1M.).

A Black zinc chromated → MY□□-16B-Stroke B Nickel plated → MY□□-16BW-Stroke

* Seal kit includes 14, 15, 16, 17 and 19. Order the seal kit based on each bore size.

* Seal kit includes a grease pack (10 g).

When 12 and 13 are shipped as single units, a grease pack (10 g per 1000 strokes) is included.

Order with the following part number when only the grease pack is needed.

Grease pack part no.: GR-S-010 (10 g), GR-S-020 (20 g)

Series MY2C

ø16, ø25, ø40

Replacement
Procedure is
P.311

Construction

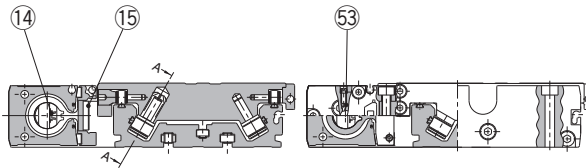
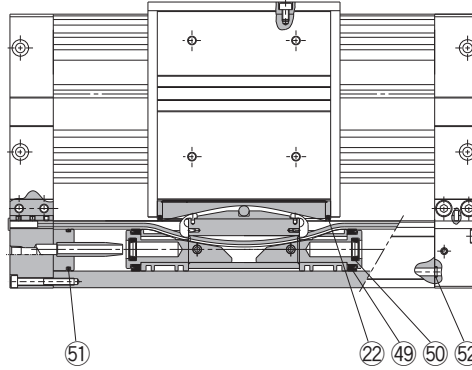

* The numbers are the same as the "Construction" of the Best Pneumatics No.2 Series MY2C.

Replacement Parts: Seal Kit

No.	Description	Qty.	MY2C16G	MY2C25G	MY2C40G	Note
14	Seal belt	1	MY16-16A-[Stroke]	MY25-16A-[Stroke]	MY40-16A-[Stroke]	14, 15 and 53 are not included in the seal kit. Order them as required with by individual part numbers.
15	Dust seal band	1	MY2H16-16B-[Stroke]	MY2H25-16B-[Stroke]	MY2H40-16B-[Stroke]	
53	O-ring	2	KA00309 (ø4 x ø1.8 x ø1.1)	KA00309 (ø4 x ø1.8 x ø1.1)	KA00320 (ø7.15 x ø3.75 x ø1.7)	
22	Scraper	2	MY2B16-PS	MY2B25-PS	MY1B40-PS	
49	Piston seal	2				
50	Cushion seal	2				
51	Tube gasket	2				
52	O-ring	4				

* Seal kit includes 22, 49, 50, 51 and 52. Order the seal kit based on each bore size.

* Seal kit includes a grease pack (10 g).

When 14 and 15 are shipped as single units, a grease pack (10 g per 1000 strokes) is included.

Order with the following part number when only the grease pack is needed.

Grease pack part no.: GR-S-010 (10 g), GR-S-020 (20 g)

Actuators

Modular F.R.L.
Pressure Control Equipment

Air Preparation
Equipment

Industrial Filters

Replacement
Procedure

Actuators

Modular F.R.L.
Pressure Control Equipment

Industrial Filters

Mechanically Jointed Rodless Cylinder/Linear Guide Type

Series MY2H/HT

ø16
ø25
ø40

Replacement
Procedure is
p.311

Construction

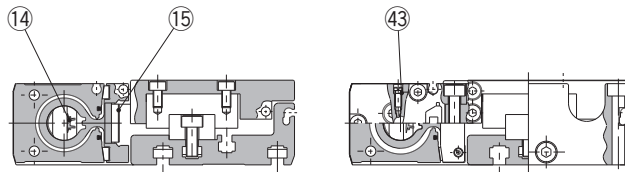
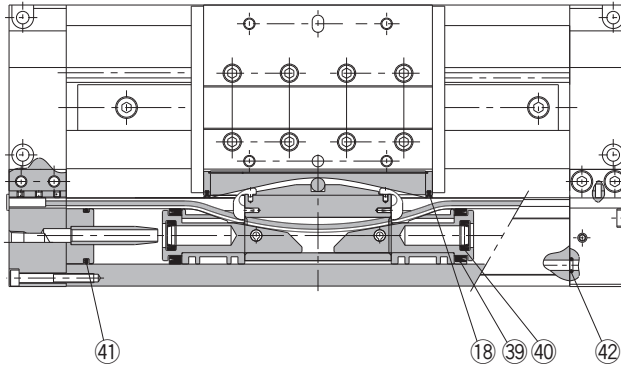

* The numbers are the same as the "Construction" of the Best Pneumatics No.2 Series MY2H/HT.

Replacement Parts: Seal Kit

No.	Description	Qty.	MY2H16G/MY2HT16G	MY2H25G/MY2HT25G	MY2H40G/MY2HT40G	Note
14	Seal belt	1	MY16-16A-Stroke	MY25-16A-Stroke	MY40-16A-Stroke	14, 15 and 43 are not included in the seal kit. Order them as required with by individual part numbers.
15	Dust seal band	1	MY2H16-16B-Stroke	MY2H25-16B-Stroke	MY2H40-16B-Stroke	
43	O-ring	2	KA00309 (ø4 x ø1.8 x ø1.1)	KA00309 (ø4 x ø1.8 x ø1.1)	KA00320 (ø7.15 x ø3.75 x ø1.7)	
18	Scraper	2	MY2B16-PS	MY2B25-PS	MY2B40-PS	
39	Piston seal	2				
40	Cushion seal	2				
41	Tube gasket	2				
42	O-ring	4				

* Seal kit includes 18, 39, 40, 41 and 42. Order the seal kit based on each bore size.

* Seal kit includes a grease pack (10 g).

When 14 and 15 are shipped as single units, a grease pack (20 g) is included.

Order with the following part number when only the grease pack is needed.

Grease pack part no.: GR-S-010 (10 g), GR-S-020 (20 g)

Series MY3A ø16, ø25, ø40, ø63

Replacement
Procedure is
P.312

Construction

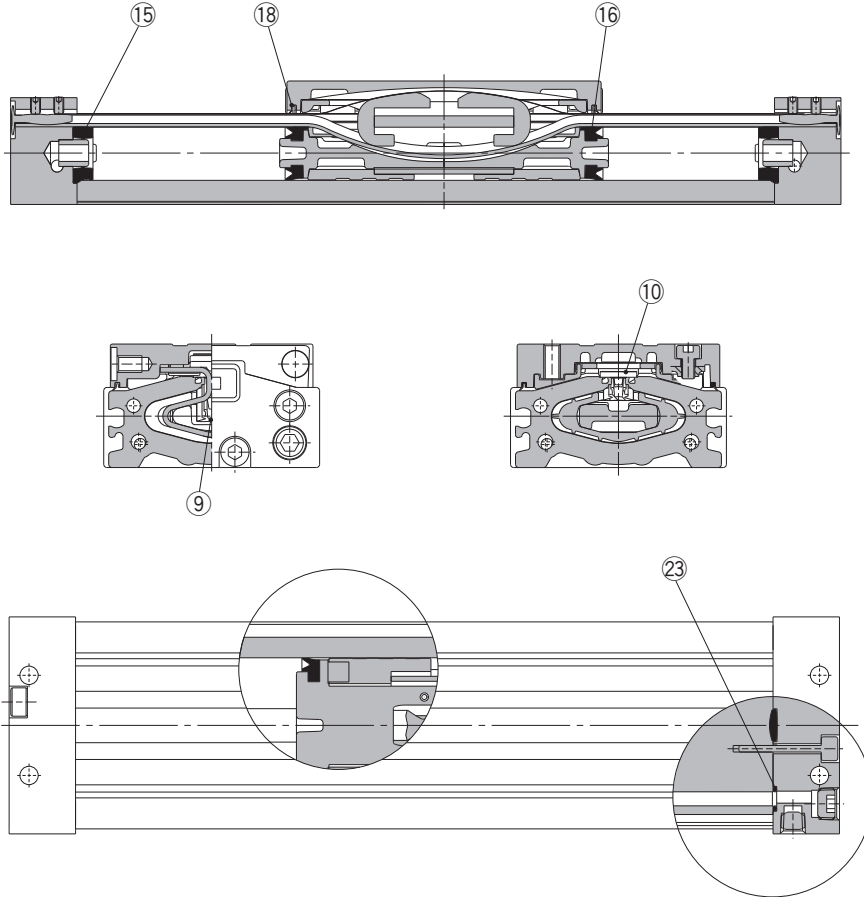

* The numbers are the same as the "Construction" of the MY3 series catalog (CAT.ES20-165).

Replacement Parts: Seal (Order them as required with by individual part numbers.)

No.	Description	Material	Qty.	MY3A16	MY3A25	MY3A40	MY3A63
9	Seal belt	Polyamide	1	MY3A16-16A-Stroke	MY3A25-16A-Stroke	MY3A40-16A-Stroke	MY3A63-16A-Stroke
10	Dust seal band	Stainless steel	1	MY3A16-16B-Stroke	MY3A25-16B-Stroke	MY3A40-16B-Stroke	MY3A63-16B-Stroke
15	Gasket bumper	NBR	2	RMA-16	RMA-25	RMA-40	RMA-63
16	Piston seal	NBR	2	RMY-16	RMY-25	RMY-40	RMY-63
18	Scraper	Polyamie	1	MYA16-15-R6656	MYA25-15-R6657	MYA40-15-R6658	MYA63-15-R6659
23	O-ring	NBR	4	KA00020 (ø6.2 x ø3 x ø1.6)	KA00048 —	KA00156 (ø10.5 x ø8.5 x ø1)	KA00036 —

* When 9 and 10 are shipped as single units, a grease pack is included (10 g per 1000 strokes).

Order with the following part number when only the grease pack is needed.

Grease pack part no.: GR-S-010 (10 g), GR-S-020 (20 g)

* For instructions on how to replace replacement parts/seals, refer to the operation manual.

Actuators

Modular F.R.L.
Pressure Control Equipment

Air Preparation
Equipment

Industrial Filters

Replacement
Procedure

Actuators

Modular F.R.L.
Pressure Control Equipment

Industrial Filters

Series MY3A $\varnothing 20, \varnothing 32, \varnothing 50$



Construction

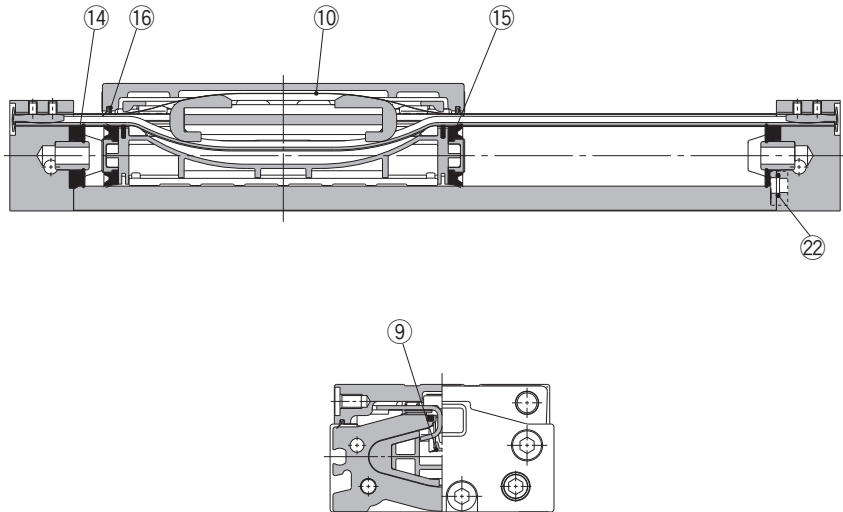

* The numbers are the same as the "Construction" of the MY3 series catalog (CAT.ES20-165).

Replacement Parts: Seal (Order them as required with by individual part numbers.)

No.	Description	Material	Qty.	MY3A20	MY3A32	MY3A50
9	Seal belt	Polyamide	1	MY3A20-16A-Stroke	MY3A32-16A-Stroke	MY3A50-16A-Stroke
10	Dust seal band	Stainless steel	1	MY3A20-16B-Stroke	MY3A32-16B-Stroke	MY3A50-16B-Stroke
14	Gasket bumper	NBR	2	RMA-20	RMA-32	RMA-50
15	Piston seal	NBR	2	RMY-20	RMY-32	RMY-50
16	Scraper	Polyamie	2	MYA20-15-AC594	MYA32-15-AC595	MYA50-15-AC596
22	O-ring	NBR	4	KA00048	KA00050	KA00035

* When ⑨ and ⑩ are shipped as single units, a grease pack is included (10 g per 1000 strokes).

Order with the following part number when only the grease pack is needed.

Grease pack part no.: GR-S-010 (10 g), GR-S-020 (20 g)

* For instructions on how to replace replacement parts/seals, refer to the operation manual.

Series MY3B

ø16, ø25, ø40, ø63

Replacement
Procedure is
P.312

Construction

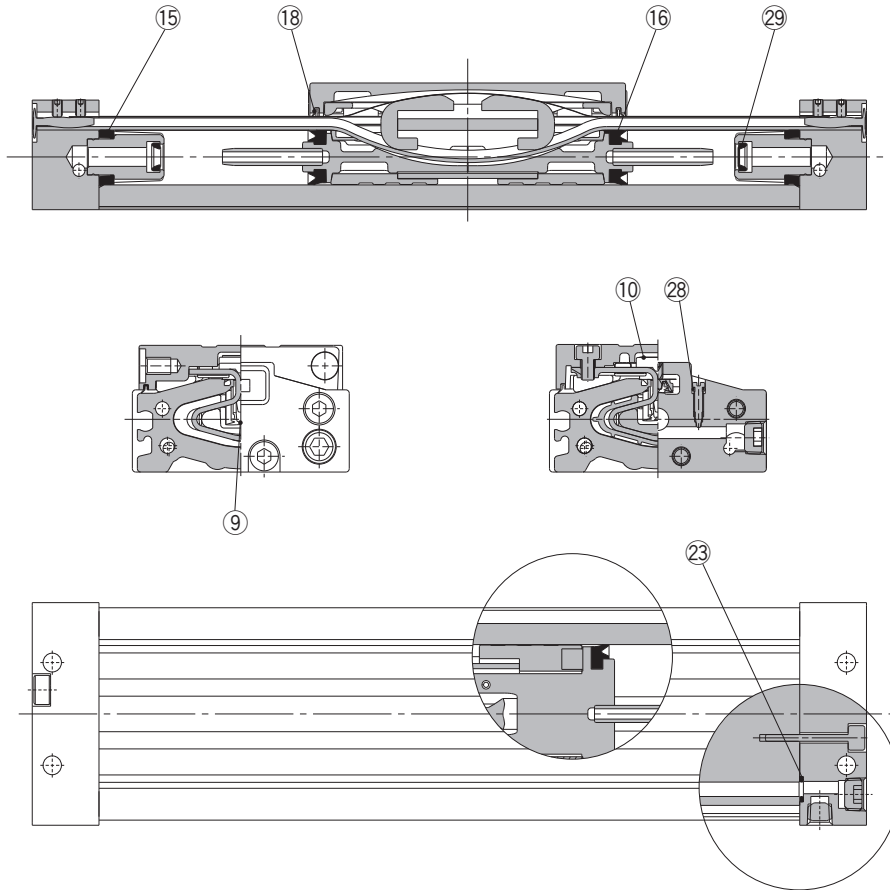

* The numbers are the same as the "Construction" of the MY3 series catalog (CAT.ES20-165).

Replacement Parts: Seal (Order them as required with by individual part numbers.)

No.	Description	Material	Qty.	MY3B16	MY3B25	MY3B40	MY3B63
9	Seal belt	Polyamide	1	MY3B16-16A-Stroke	MY3B25-16A-Stroke	MY3B40-16A-Stroke	MY3B63-16A-Stroke
10	Dust seal band	Stainless steel	1	MY3B16-16B-Stroke	MY3B25-16B-Stroke	MY3B40-16B-Stroke	MY3B63-16B-Stroke
15	Tube gasket	NBR	2	RMB-16	RMB-25	RMB-40	RMB-63
16	Piston seal	NBR	2	RMY-16	RMY-25	RMY-40	RMY-63
18	Scraper	Polyamide	1	MYA16-15-R6656	MYA25-15-R6657	MYA40-15-R6658	MYA63-15-R6659
23	O-ring	NBR	4	KA00020 (ø6.2 x ø3 x ø1.6)	KA00048 —	KA00156 (ø10.5 x ø8.5 x ø1)	KA00036 —
28	O-ring	NBR	2	KA00309 (ø4 x ø1.8 x ø1.1)	KA00309 (ø4 x ø1.8 x ø1.1)	KA00320 (ø7.15 x ø3.75 x ø1.7)	KA00402 (ø8.3 x ø4.5 x ø1.9)
29	Cushion seal	NBR	2	MCS-3	MCS-5	RCS-8	RCS-12

* When ⑨ and ⑩ are shipped as single units, a grease pack is included (10 g per 1000 strokes).

Order with the following part number when only the grease pack is needed.

Grease pack part no.: GR-S-010 (10 g), GR-S-020 (20 g)

* For instructions on how to replace replacement parts/seals, refer to the operation manual.

Series MY3B

ø20, ø32, ø50

Replacement
Procedure is
P.312

Construction

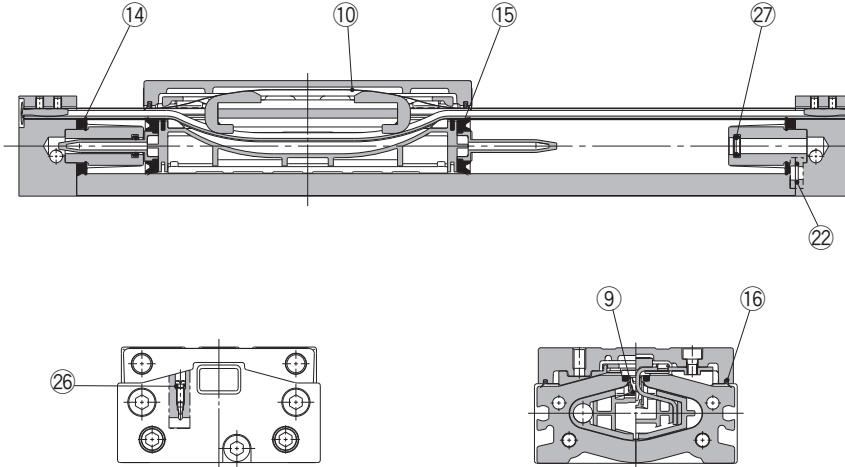

* The numbers are the same as the "Construction" of the MY3 series catalog (CAT.ES20-165).

Replacement Parts: Seal (Order them as required with by individual part numbers.)

No.	Description	Material	Qty.	MY3B20	MY3B32	MY3B50
9	Seal belt	Polyamide	1	MY3B20-16A-Stroke	MY3B32-16A-Stroke	MY3B50-16A-Stroke
10	Dust seal band	Stainless steel	1	MY3B20-16B-Stroke	MY3B32-16B-Stroke	MY3B50-16B-Stroke
14	Tube gasket	NBR	2	RMB-20	RMB-32	RMB-50
15	Piston seal	NBR	2	RMY-20	RMY-32	RMY-50
16	Scraper	Polyamide	2	MYA20-15-AC594	MYA32-15-AC595	MYA50-15-AC596
22	O-ring	NBR	4	KA00048	KA00050	KA00035
26	O-ring	NBR	2	KA00309 (ø4 x ø1.8 x ø1.1)	KA00309 (ø4 x ø1.8 x ø1.1)	KA00320 (ø7.15 x ø3.75 x ø1.7)
27	Cushion seal	NBR	2	MCS-3	MCS-5	RCS-8

* When ⑨ and ⑩ are shipped as single units, a grease pack is included (10 g per 1000 strokes).

Order with the following part number when only the grease pack is needed.

Grease pack part no.: GR-S-010 (10 g), GR-S-020 (20 g)

* For instructions on how to replace replacement parts/seals, refer to the operation manual.

Series MY3M

ø16, ø25, ø40, ø63

Replacement Procedure is p.312

Construction

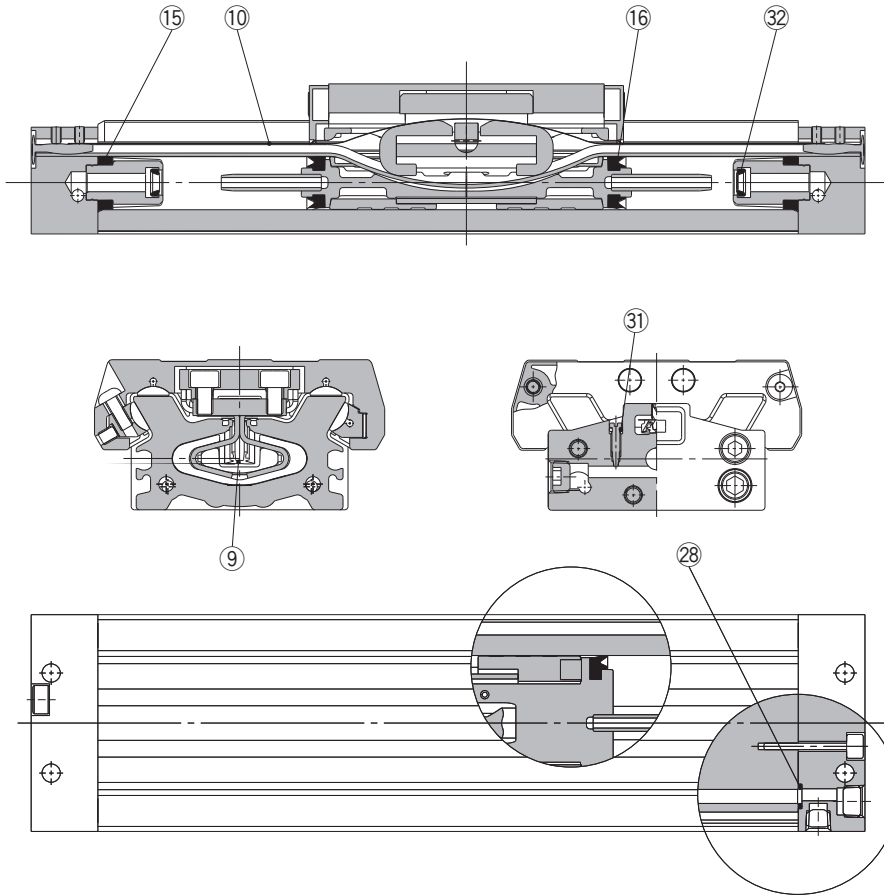

* The numbers are the same as the "Construction" of the MY3 series catalog (CAT.ES20-165).

Replacement Parts: Seal (Order them as required with by individual part numbers.)

No.	Description	Material	Qty.	MY3M16	MY3M25	MY3M40	MY3M63
9	Seal belt	Polyamide	1	MY3B16-16A-Stroke	MY3B25-16A-Stroke	MY3B40-16A-Stroke	MY3B63-16A-Stroke
10	Dust seal band	Stainless steel	1	MY3B16-16B-Stroke	MY3B25-16B-Stroke	MY3B40-16B-Stroke	MY3B63-16B-Stroke
15	Tubing gasket	NBR	2	RMB-16	RMB-25	RMB-40	RMB-63
16	Piston seal	NBR	2	RMY-16	RMY-25	RMY-40	RMY-63
28	O-ring	NBR	4	KA00020 (ø6.2 x ø3 x ø1.6)	KA00048 —	KA00156 (ø10.5 x ø8.5 x ø1)	KA00036 —
31	O-ring	NBR	2	KA00309 (ø4 x ø1.8 x ø1.1)	KA00309 (ø4 x ø1.8 x ø1.1)	KA00320 (ø7.15 x ø3.75 x ø1.7)	KA00402 (ø8.3 x ø4.5 x ø1.9)
32	Cushion seal	NBR	2	MCS-3	MCS-5	RCS-8	RCS-12

* Since the seal kit does not include a grease pack, order it separately.

Grease pack part no.: GR-S-010 (10 g)

* For instructions on how to replace replacement parts/seals, refer to the operation manual.

Series CY3B

ø6, ø10, ø15, ø20, ø25
ø32, ø40, ø50, ø63

Replacement
Procedure is
p.315

Construction

Basic type CY3B6

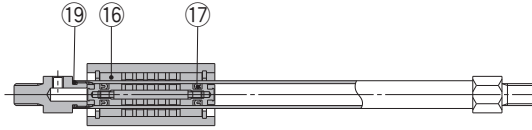

CY3B10, 15

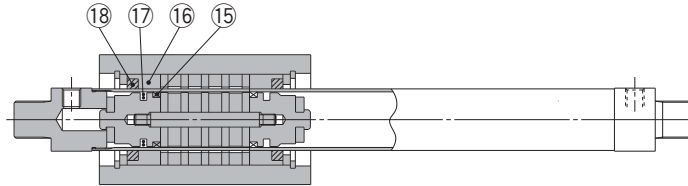

* The above drawing is ø15. (3 magnets are used in ø10.)

CY3B20 to 40

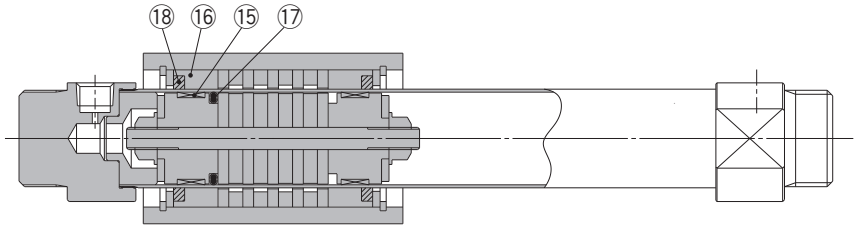

CY3B50, 63

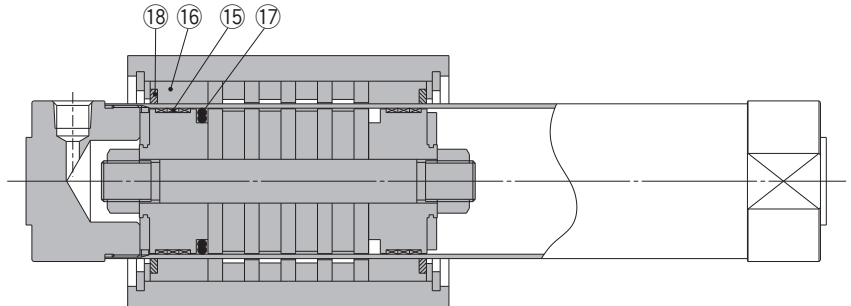

* The numbers are the same as the "Construction" of the Best Pneumatics No.2 Series CY3B.

Seal Kit List

No.	Description	Material	Note
15	Wear ring A	Special resin	ø6, ø10: Not available
16	Wear ring B	Special resin	
17	Piston seal	NBR	
18	Lubretainer	Special resin	ø6: Not available
19	Cylinder tube gasket	NBR	ø6, ø10 only

* Seal kit includes a grease pack (ø6, ø10: 5 and 10 g, ø15 to ø63: 10 g).
Order with the following part number when only the grease pack is needed.

Grease pack part no. for ø6, ø10: GR-F-005 (5 g) for external sliding sections
GR-S-010 (10 g) for tubing interior

Grease pack part no. for ø15 to ø63: GR-S-010 (10 g)

Replacement Parts/Seal Kit

Bore size (mm)	Kit no.	Contents
6	CY3B6-PS	Set of left nos. 16, 17, 19
10	CY3B10-PS	Set of left nos. 16, 17, 18, 19
15	CY3B15-PS	Set of left nos. 15, 16, 17, 18
20	CY3B20-PS	
25	CY3B25-PS	
32	CY3B32-PS	
40	CY3B40-PS	
50	CY3B50-PS	
63	CY3B63-PS	

Note 1) Seal kits are sets consisting of numbers 15 through 19. Order using the kit number corresponding to each bore size.

Note 2) Adhesive glue is applied to the thread fixed section of the head cover and cylinder tube. Contact SMC if the head cover removal is difficult.

Note 3) For wear ring A of ø10, please consult with SMC.

Series CY3R

ø6, ø10, ø15, ø20
ø25, ø32, ø40, ø50
ø63

Replacement
Procedure is
p.316

Construction

Both sides piping type

CY3R6

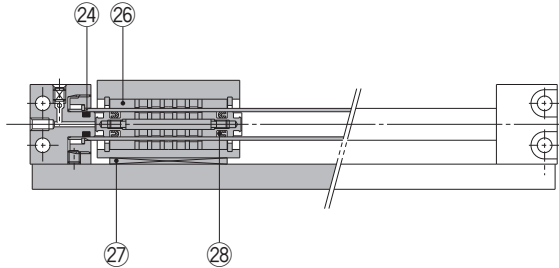

CY3R10

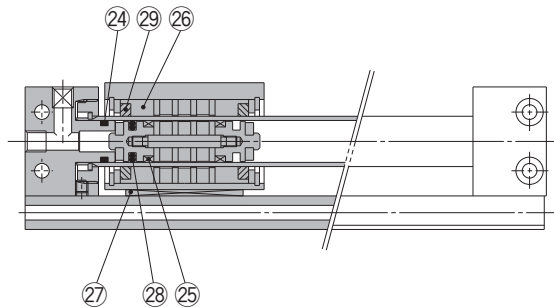

CY3R15 to 63

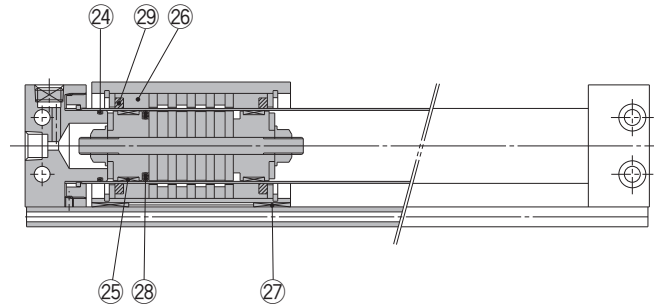

* The numbers are the same as the "Construction" of the Best Pneumatics No.2 Series CY3R.

Seal Kit List

No.	Description	Material	Note
24	Cylinder tube gasket	NBR	
25	Wear ring A	Special resin	ø6, ø10: Not available
26	Wear ring B	Special resin	
27	Wear ring C	Special resin	
28	Piston seal	NBR	
29	Lubretainer	Special resin	ø6: Not available
30	Switch rail gasket	NBR	Both sides piping type: None

* Seal kit includes a grease pack (ø6, ø10: 5 and 10 g, ø15 to ø63: 10 g). Order with the following part number when only the grease pack is needed.

Grease pack part no. for ø6, ø10: GR-F-005 (5 g) for external sliding sections
GR-S-010 (10 g) for tubing interior

Grease pack part no. for ø15 to ø63: GR-S-010 (10 g)

Replacement Parts/Seal Kit

Bore size (mm)	Kit no.	Contents
6	CY3R6-PS	Set of left nos. 24, 26, 27, 28
10	CY3R10-PS	Set of left nos. 24, 26, 27, 28, 29, 30
15	CY3R15-PS	Set of left nos. 24, 25, 26, 27, 28, 29, 30
20	CY3R20-PS	
25	CY3R25-PS	
32	CY3R32-PS	
40	CY3R40-PS	
50	CY3R50-PS	
63	CY3R63-PS	

Note 1) Seal kits are the same for both the both sides piping type and the centralized piping type.

Note 2) Seal kits are sets consisting of numbers 24 through 30. Order using the kit number corresponding to each bore size.

Note 3) For wear ring A of ø10, please consult with SMC.

Actuators

Modular F.R.L.
Pressure Control Equipment

Air Preparation
Equipment

Industrial Filters

Replacement
Procedure

Actuators

Modular F.R.L.
Pressure Control Equipment

Industrial Filters

Series CY3R

ø6, ø10, ø15, ø20
ø25, ø32, ø40, ø50
ø63

Replacement
Procedure is
p.316

Construction

Centralized piping type

CY3RG10

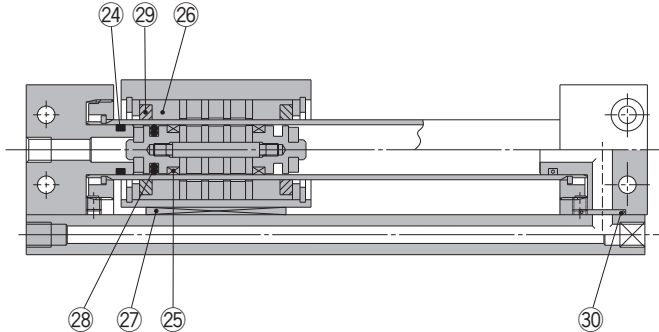

CY3RG15 to 63

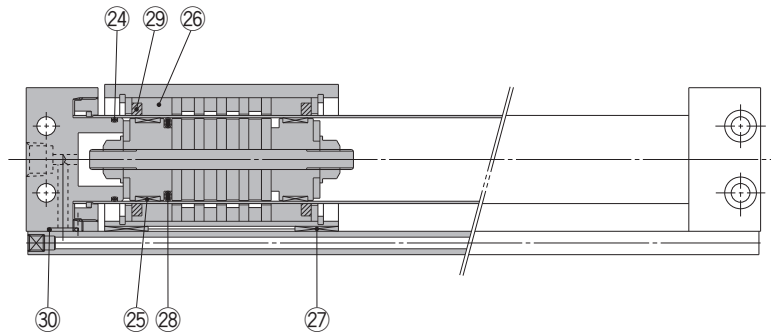

* The numbers are the same as the "Construction" of the Best Pneumatics No.2 Series CY3R.

Seal Kit List

No.	Description	Material	Note
24	Cylinder tube gasket	NBR	
25	Wear ring A	Special resin	ø6, ø10: Not available
26	Wear ring B	Special resin	
27	Wear ring C	Special resin	
28	Piston seal	NBR	
29	Lubretainer	Special resin	ø6: Not available
30	Switch rail gasket	NBR	Both sides piping type: None

Replacement Parts: Seal Kit

Bore size (mm)	Kit no.	Contents
10	CY3R10-PS	Set of left nos. 24, 26, 27, 28, 29, 30
15	CY3R15-PS	Set of left nos. 24, 25, 26, 27, 28, 29, 30
20	CY3R20-PS	
25	CY3R25-PS	
32	CY3R32-PS	
40	CY3R40-PS	
50	CY3R50-PS	
63	CY3R63-PS	

Note 1) Seal kits are the same for both the both sides piping type and the centralized piping type.

Note 2) Seal kits are sets consisting of numbers 24 through 30. Order using the kit number corresponding to each bore size.

Note 3) For wear ring A of ø10, please consult with SMC.

* Seal kit includes a grease pack (ø6, ø10: 5 and 10 g, ø15 to ø63: 10 g). Order with the following part number when only the grease pack is needed.

Grease pack part no. for ø6, ø10: GR-F-005 (5 g) for external sliding sections
GR-S-010 (10 g) for tubing interior

Grease pack part no. for ø15 to ø63: GR-S-010 (10 g)

Series CY1S

ø6, ø10, ø15, ø20
ø25, ø32, ø40

Replacement
Procedure is
P.317

Construction

Slider type, slide bearing

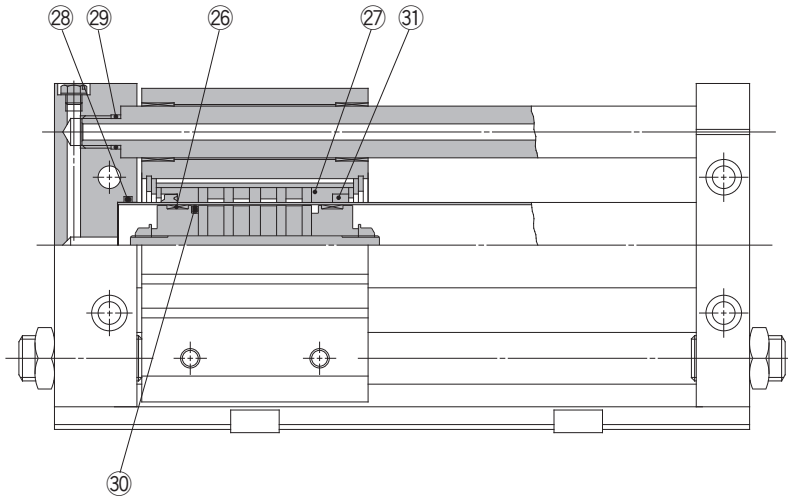

* This figure is for a representative cylinder CDY1S25H

* The numbers are the same as the "Construction" of the Best Pneumatics No.2 Series CY1S.

Seal Kit List

No.	Description	Material	Note
26	Wear ring A	Special resin	ø6, ø10: Not available
27	Wear ring B	Special resin	
28	Cylinder tube gasket	NBR	
29	Guide shaft gasket	NBR	
30	Piston seal	NBR	
31	Scraper	NBR	ø6: Not available

Replacement Parts: Seal Kit

Bore size (mm)	Kit no.	Contents
6	CY1S6-PS-N	Set of left nos. 27, 28, 29, 30
10	CY1S10-PS-N	Set of left nos. 27, 28, 29, 30, 31
15	CY1S15-PS-N	Set of left nos. 26, 27, 28, 29, 30, 31
20	CY1S20-PS-N	
25	CY1S25-PS-N	
32	CY1S32-PS-N	
40	CY1S40-PS-N	

Note 1) Seal kit includes 27 to 30 for ø6. 27 to 31 are for ø10. 20 to 31 are for ø15 to ø40. Order the seal kit, based on each bore size.

Note 2) For wear ring A of ø10, please consult with SMC.

* Seal kit includes a grease pack (ø6, ø10: 5 and 10 g, ø15 to ø40: 10 g). Order with the following part number when only the grease pack is needed.

Grease pack part no. for ø6, ø10: GR-F-005 (5 g) for external sliding parts,

GR-S-010 (10 g) for tube interior

Grease pack part no. for ø15 to ø40: GR-S-010 (10 g)

Series CY1L

ø6, ø10, ø15, ø20
ø25, ø32, ø40

Replacement
Procedure is
P.318

Construction

Slider type, ball bushing bearing

CY1L6

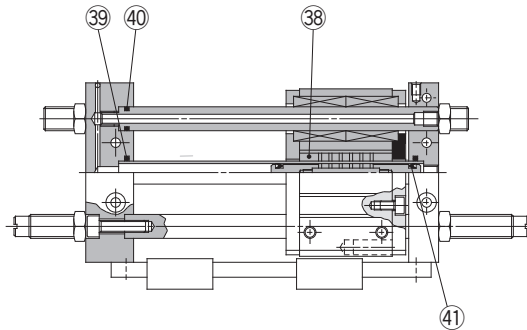

CY1L10 to 40

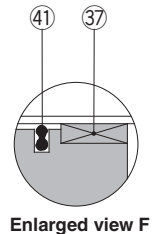
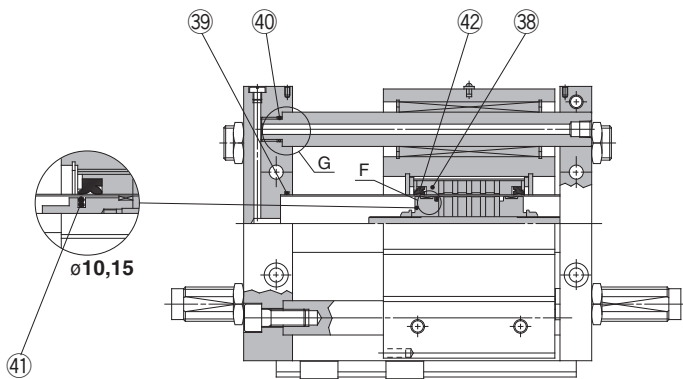
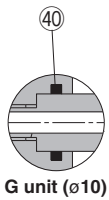

* The numbers are the same as the "Construction" of the Best Pneumatics No.2 Series CY1L.

Seal Kit List

No.	Description	Material	Note
37	Wear ring A	Special resin	ø6, ø10: Not available
38	Wear ring B	Special resin	
39	Cylinder tube gasket	NBR	
40	Guide shaft gasket	NBR	
41	Piston seal	NBR	
42	Scraper	NBR	ø6: Not available

Replacement Parts: Seal Kit

Bore size (mm)	Kit no.	Contents
6	CY1S6-PS-N	Set of left nos. 38, 39, 40, 41
10	CY1L10-PS-N	Set of left nos. 38, 39, 40, 41, 42
15	CY1L15-PS-N	Set of left nos. 37, 38, 39, 40, 41, 42
20	CY1L20-PS-N	
25	CY1L25-PS-N	
32	CY1L32-PS-N	
40	CY1L40-PS-N	

Note 1) Seal kit includes 38 to 41 for ø6. 38 to 42 are for ø10. 37 to 42 are for ø15 to ø40. Order the seal kit, based on each bore size.

Note 2) ø6 are the same as for CY1S6.

Note 3) For wear ring A of ø10, please consult with SMC.

* Seal kit includes a grease pack (ø6, ø10: 5 and 10 g, ø15 to ø40: 10 g). Order with the following part number when only the grease pack is needed.

Grease pack part no. for ø6, ø10: GR-F-005 (5 g) for external sliding parts,
GR-S-010 (10 g) for tube interior
Grease pack part no. for ø15 to ø40: GR-S-010 (10 g)

Series CY1H

Single Axis Type:
 $\phi 10$, $\phi 15$, $\phi 20$, $\phi 25$

Construction

Single axis type

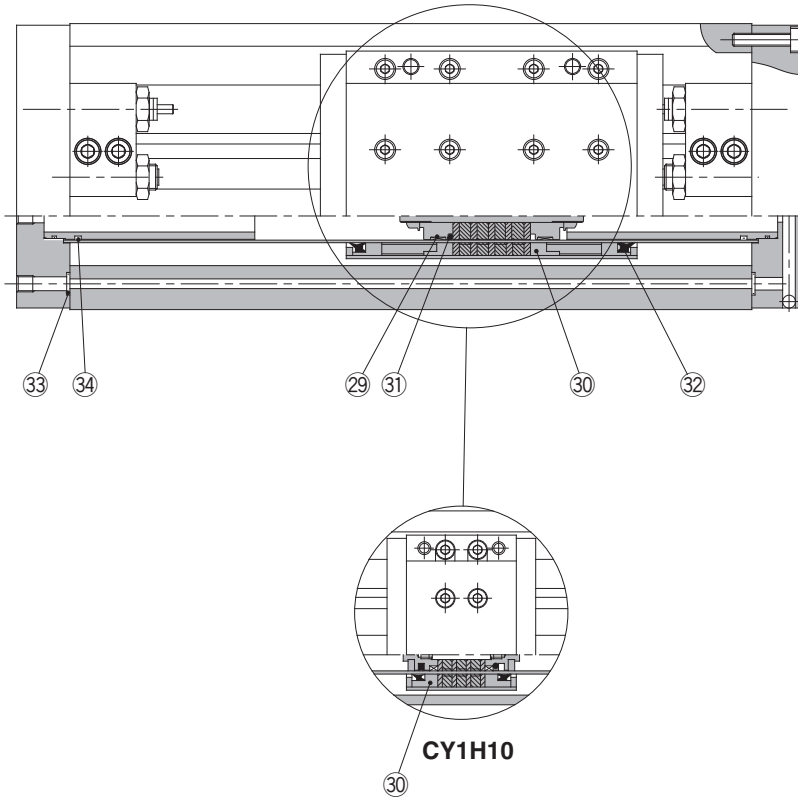

* The numbers are the same as the "Construction" of the Best Pneumatics No.2 Series CY1H.

Seal Kit List

No.	Description	Material	Note
29	Wear ring A	Special resin	$\phi 10$: Not available
30	Wear ring B	Special resin	
31	Piston seal	NBR	
32	Scraper	NBR	
33	O-ring	NBR	
34	O-ring	NBR	

Replacement Parts: Seal Kit

Bore size (mm)	Kit no.	Contents
10	CY1H10-PS	Set of left nos. 30, 31, 32, 33, 34
15	CY1H15-PS	Set of left nos. 29, 30, 31, 32, 33, 34
20	CY1H20-PS	
25	CY1H25-PS	

Note 1) Seal kit includes 30 to 34 for $\phi 10$. 29 to 34 are for $\phi 15$ to $\phi 25$.
 Order the seal kit, based on each bore size.

Note 2) For wear ring A of $\phi 10$, please consult with SMC.

* Seal kit includes a grease pack ($\phi 10$: 5 and 10 g, $\phi 15$ to $\phi 25$: 10 g).
 Order with the following part number when only the grease pack is needed.

Grease pack part no. for $\phi 10$: GR-F-005 (5 g) for external sliding parts,
GR-S-010 (10 g) for tube interior

Grease pack part no. for $\phi 15$ to $\phi 25$: GR-S-010 (10 g)

Magnetically Coupled Rodless Cylinder/Linear Guide Type

Series *CY1H* Double Axis Type: $\varnothing 25, \varnothing 32$

Construction

Double axes type

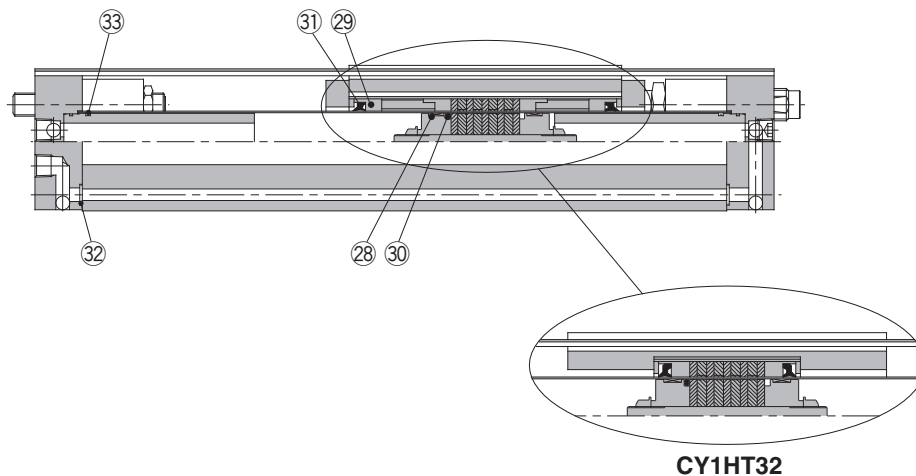

* The numbers are the same as the "Construction" of the Best Pneumatics No.2 Series CY1H.

Seal Kit List

No.	Description	Material	Material
28	Wear ring A	Special resin	
29	Wear ring B	Special resin	
30	Piston seal	NBR	
31	Scraper	NBR	
32	O-ring	NBR	
33	O-ring	NBR	

Replacement Parts: Seal Kit

Bore size (mm)	Kit no.	Contents
25	CY1HT25-PS	Set of left nos.
32	CY1HT32-PS	28, 29, 30, 31, 32, 33

Note 1) Seal kit includes 28 to 33. Order the seal kit, based on each bore size.

* Seal kit includes a grease pack (10 g).

Order with the following part number when only the grease pack is needed.

Grease pack part no.: GR-S-010 (10 g)

Series MXS

Replacement
Procedure is
P.319

Construction

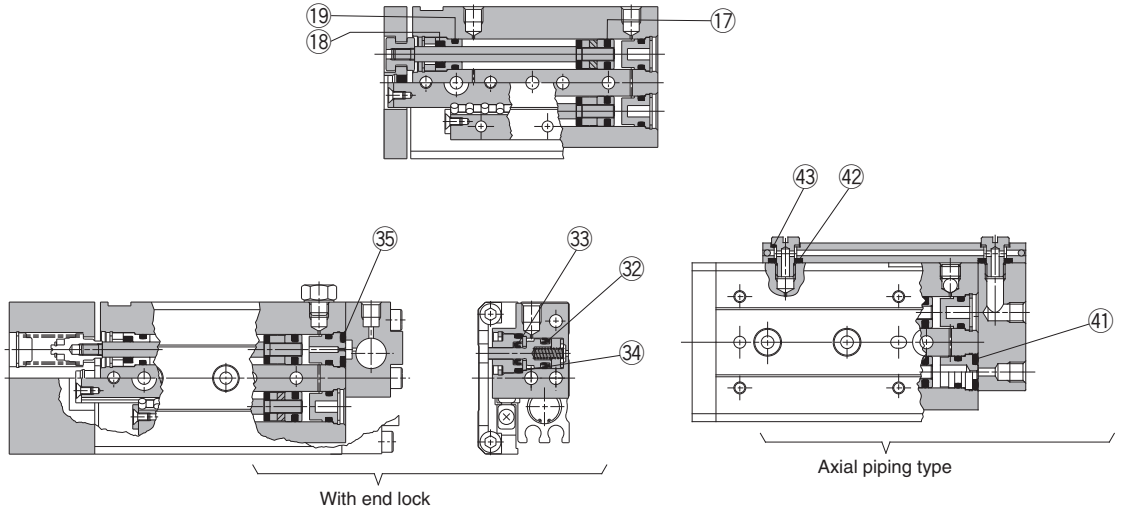

* The numbers are the same as the "Construction" of the Best Pneumatics No.3 Series MXS.

Seal Kit List

No.	Description	Material	Note
17	Piston seal	NBR	
18	Rod seal		
19	O-ring		

With end lock

32	Piston seal	NBR	
33	Rod seal		
34	O-ring		
35	O-ring		

Axial piping type

41	O-ring	NBR	
42	O-ring	NBR	
43	Gasket		

* Seal kit includes 1 set of numbered seals in the table on the right.
Order the appropriate seal kit depending on the cylinder bore size.

Replacement Parts: Seal Kit

Bore size (mm)	Kit no.	Contents
6	MXS6-PS	Set of left nos. 17, 18, 19
8	MXS8-PS	
12	MXS12-PS	
16	MXS16-PS	
20	MXS20-PS	
25	MXS25-PS	

Replacement Parts: Seal Kit for with End Lock

Bore size (mm)	Kit no.	Contents
8	MXS8R-PS	Set of left nos. 17, 18, 19, 32, 33, 34, 35
12	MXS12R-PS	
16	MXS16R-PS	
20	MXS20R-PS	
25	MXS25R-PS	

Replacement Parts: Seal Kit for Axial Piping Type

Bore size (mm)	Kit no.	Contents
6	MXS6P-PS	Set of left nos. 17, 18, 19, 41, 42, 43
8	MXS8P-PS	
12	MXS12P-PS	
16	MXS16P-PS	
20	MXS20P-PS	
25	MXS25P-PS	

Replacement Parts: Grease Pack

Applied unit	Grease pack part no.
Guide unit	GR-S-010 (10 g) GR-S-020 (20 g)
Cylinder unit	GR-L-005 (5 g) GR-L-010 (10 g)

Actuators

Modular F.R.L.
Pressure Control Equipment

Air Preparation
Equipment

Industrial Filters

Replacement
Procedure

Actuators

Modular F.R.L.
Pressure Control Equipment

Industrial Filters

Series MXQ

ø6, ø8, ø12, ø16
ø20, ø25



Construction

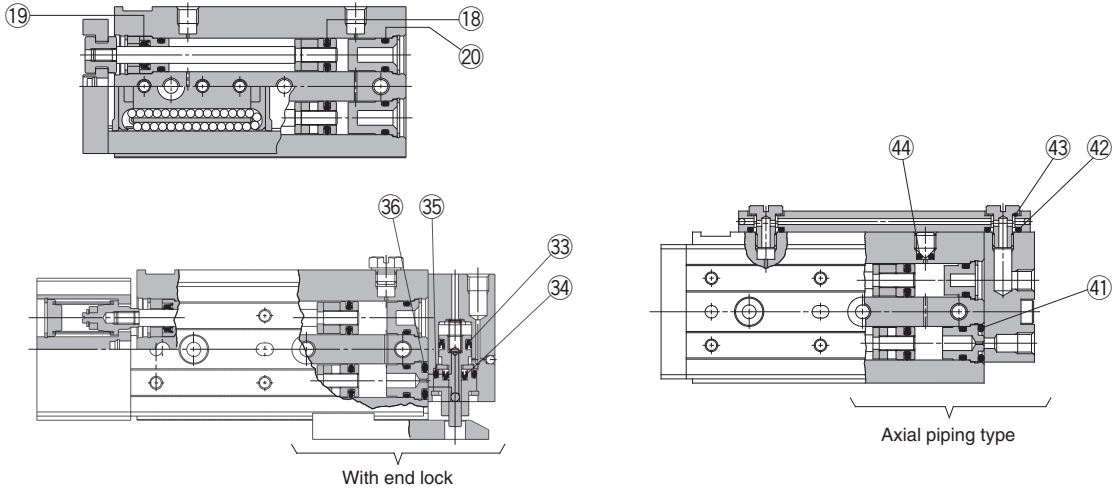

* The numbers are the same as the "Construction" of the Best Pneumatics No.3 Series MXQ.

Seal Kit List

No.	Description	Material	Note
18	Piston seal	NBR	
19	Rod seal		
20	O-ring		

With end lock

33	Piston seal	NBR	
34	Rod seal		
35	O-ring		
36	O-ring		

Axial piping type

41	O-ring	NBR	
42	O-ring	NBR	
43	Gasket	NBR, Stainless steel	
44	O-ring	NBR	

* Seal kit includes these seals to provide as a set. Order the seal kit, based on each bore size.

Replacement Parts: Seal Kit

Bore size (mm)	Kit no.	Contents
6	MXQ6-PS	Set of left nos. 18, 19, 20
8	MXQ8-PS	
12	MXQ12-PS	
16	MXQ16-PS	
20	MXQ20-PS	
25	MXQ25-PS	

Replacement Parts: Seal Kit for with End Lock

Bore size (mm)	Kit no.	Contents
8	MXQ8R-PS	Set of left nos. 18, 19, 20, 33, 34, 35, 36
12	MXQ12R-PS	
16	MXQ16R-PS	
20	MXQ20R-PS	
25	MXQ25R-PS	

Replacement Parts: Seal Kit for Axial Piping Type

Bore size (mm)	Kit no.	Contents
6	MXQ6P-PS	Set of left nos. 18, 19, 20, 41, 42, 43, 44
8	MXQ8P-PS	
12	MXQ12P-PS	
16	MXQ16P-PS	Set of left nos. 18, 19, 20, 41, 42, 43
20	MXQ20P-PS	
25	MXQ25P-PS	

Replacement Parts: Grease Pack

Applied section	Grease pack part no.
Guide	GR-S-010 (10 g)
	GR-S-020 (20 g)
Cylinder	GR-L-005 (5 g)
	GR-L-010 (10 g)

Series MXQR

ø6, ø8, ø12
ø16, ø20, ø25

Replacement
Procedure is
p.319

Construction

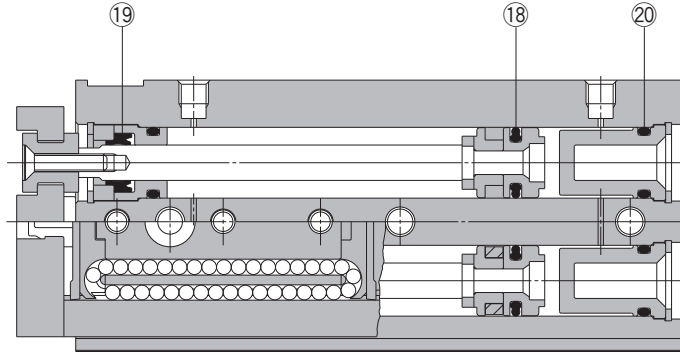

* The numbers are the same as the "Construction" of the MXQR series catalog (CAT.ES20-203).

Seal Kit List

No.	Description	Material	Note
18	Piston seal	NBR	
19	Rod seal		
20	O-ring		

Replacement Parts: Seal Kit

Bore size (mm)	Kit no.	Contents
6	MXQ6-PS	Set of left nos. 18, 19, 20
8	MXQ8-PS	
12	MXQ12-PS	
16	MXQ16-PS	
20	MXQ20-PS	
25	MXQ25-PS	

* Seal kit includes these seals to provide as a set. Order the seal kit, based on each bore size.

Replacement Parts: Grease Pack

Applied part	Grease pack part no.
Guide unit	GR-S-010 (10 g)
	GR-S-020 (20 g)
Cylinder unit	GR-L-005 (5 g)
	GR-L-010 (10 g)

Actuators

Modular F.R.L.
Pressure Control Equipment

Air Preparation
Equipment

Industrial Filters

Replacement
Procedure

Actuators

Modular F.R.L.
Pressure Control Equipment

Industrial Filters

Series MXF



Construction

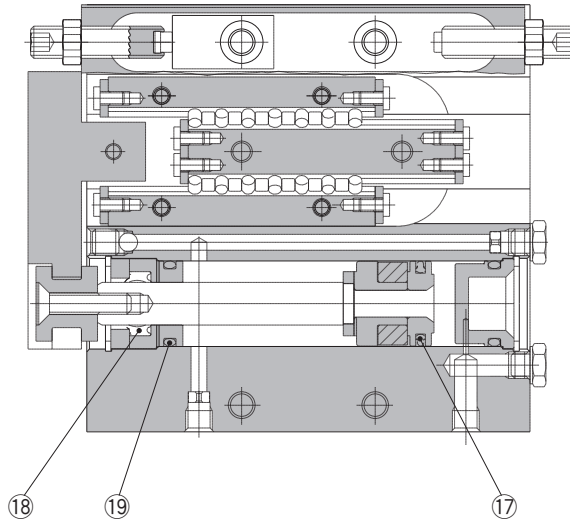

* The numbers are the same as the "Construction" of the Best Pneumatics No.3 Series MXF.

Seal Kit List

No.	Description	Material	Note
⑰	Piston seal	NBR	
⑱	Rod seal		
⑲	O-ring		

Replacement Parts: Seal Kit

Bore size (mm)	Kit no.	Contents
8	MXF8-PS	Set of left nos. ⑰, ⑱, ⑲
12	MXF12-PS	
16	MXF16-PS	
20	MXF20-PS	

* Seal kit includes ⑰, ⑱, ⑲. Order the seal kit, based on each bore size.

Replacement Parts: Grease Pack

Applied part	Grease pack part no.
Guide	GR-S-010 (10 g)
	GR-S-020 (20 g)
Cylinder	GR-L-005 (5 g)
	GR-L-010 (10 g)

Series MXW

Replacement Procedure is p.325

Construction

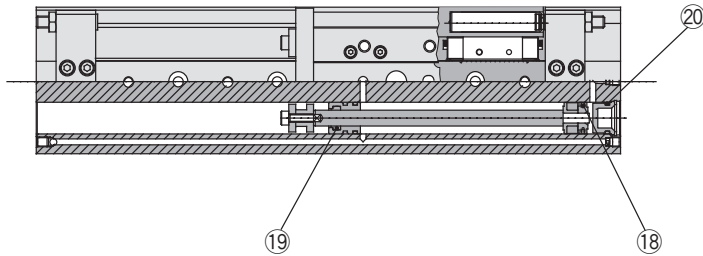

* The numbers are the same as the "Construction" of the Best Pneumatics No.3 Series MXW.

Seal Kit List

No.	Description	Material	Note
18	Piston seal	NBR	
19	Rod seal		
20	O-ring		

Replacement Parts: Seal Kit

Bore size (mm)	Kit no.	Contents
8	MXW8-PS	Set of left nos. 18, 19, 20
12	MXW12-PS	
16	MXW16-PS	
20	MXW20-PS	
25	MXW25-PS	

* Seal kit includes 18, 19, 20. Order the seal kit, based on each bore size.

Replacement Parts: Grease Pack

Applied part	Grease pack part no.
Guide	GR-S-010 (10 g)
	GR-S-020 (20 g)
Cylinder	GR-L-005 (5 g)
	GR-L-010 (10 g)

Actuators

Modular F.R.L.
Pressure Control Equipment

Air Preparation
Equipment

Industrial Filters

Replacement
Procedure

Actuators

Modular F.R.L.
Pressure Control Equipment

Industrial Filters

Series MXP ø6



Construction

MXP6

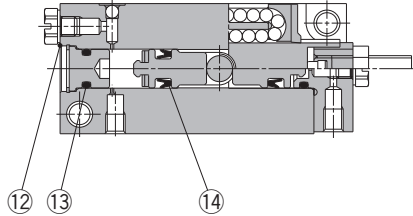

* The numbers are the same as the "Construction" of the Best Pneumatics No.3 Series MXP.

Seal Kit List

No.	Description	Material	Note
⑫	Gasket (for plug)	PVC	
⑬	O-ring	NBR	
⑭	Piston seal		

Replacement Parts: Seal Kit

Bore size (mm)	Kit no.	Contents
6	MXP6-PS	A set of two of ⑫, ⑬ and ⑭ each

Replacement Parts: Grease Pack

Applied unit	Grease pack part no.
Guide unit	GR-S-010 (10 g)
	GR-S-020 (20 g)
Cylinder unit	GR-L-005 (5 g)
	GR-L-010 (10 g)

MXPJ6

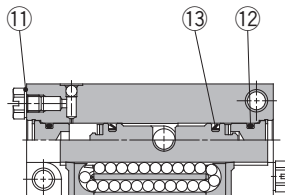

* The numbers are the same as the "Construction" of the Best Pneumatics No.3 Series MXP.

Seal Kit List

No.	Description	Material	Note
⑪	Gasket (for plug)	PVC	
⑫	O-ring	NBR	
⑬	Piston seal		

Replacement Parts: Seal Kit

Bore size (mm)	Kit no.	Contents
6	MXPJ6-PS	2 pieces of no. ⑪, ⑫ and ⑬

Replacement Parts: Grease Pack

Applied unit	Grease pack part no.
Guide unit	GR-S-010 (10 g)
	GR-S-020 (20 g)
Cylinder unit	GR-L-005 (5 g)
	GR-L-010 (10 g)

Series MXP

ø8, ø10, ø12, ø16



Construction

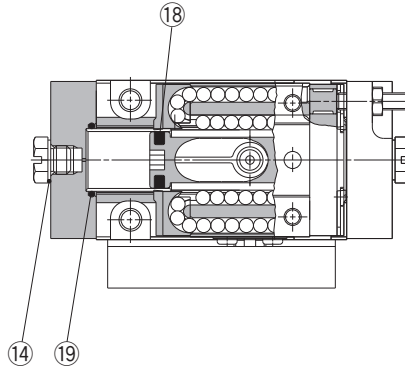

* The numbers are the same as the "Construction" of the Best Pneumatics No.3 Series MXP.

Seal Kit List

No.	Description	Material	Note
14	Gasket (for plug)	NBR, stainless steel	
18	Piston seal	NBR	
19	O-ring		

Replacement Parts: Seal Kit

Bore size (mm)	Kit no.	Contents
8	MXP8-PS	A set of two of 14, 18 and 19 each
10	MXP10-PS	
12	MXP12-PS	
16	MXP16-PS	

Replacement Parts: Grease Pack

Applied unit	Grease pack part no.
Guide unit	GR-S-010 (10 g)
	GR-S-020 (20 g)
Cylinder unit	GR-L-005 (5 g)
	GR-L-010 (10 g)

Actuators

Modular F.R.L.
Pressure Control Equipment

Air Preparation
Equipment

Industrial Filters

Replacement
Procedure

Actuators

Modular F.R.L.
Pressure Control Equipment

Industrial Filters

Construction

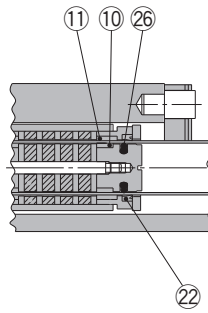
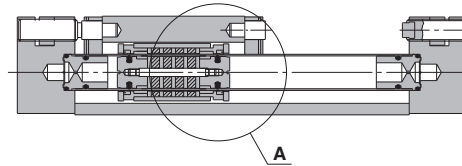

Detail drawing of part A

* The numbers are the same as the "Construction" of the Best Pneumatics No.3 Series MXY.

Seal Kit List

No.	Description	Material	Note
⑩	Wear ring A	Resin	
⑪	Wear ring B	Resin	
⑫	Cylinder scraper	NBR	
⑳	Piston seal	NBR	

Replacement Parts: Seal Kit

Bore size (mm)	Kit no.	Contents
6	MX Y6-PS	A set of two of ⑩, ⑪, ⑫ and ⑳ each
8	MX Y8-PS	
12	MX Y12-PS	

* As for MXY12, only one piston seal 26 is included.

Replacement Parts: Grease Pack

Grease pack part no.
GR-S-010 (10 g)
GR-S-020 (20 g)

Series MGP-□Z

Replacement
Procedure is
p.333

Construction: Series MGPM, MGPL, MGPA

MGPM12 to 25

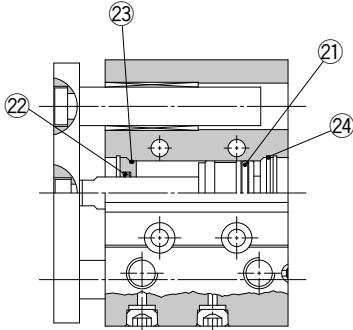

MGPM32 to 100

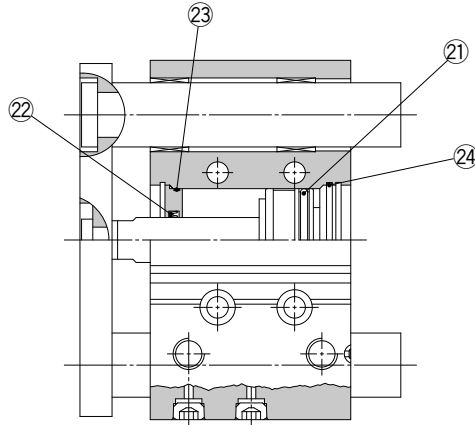

MGPL12 to 25
MGPA12 to 25

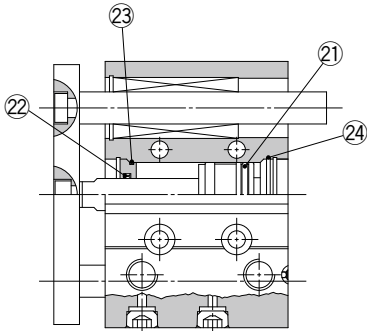

MGPL32 to 100
MGPA32 to 100

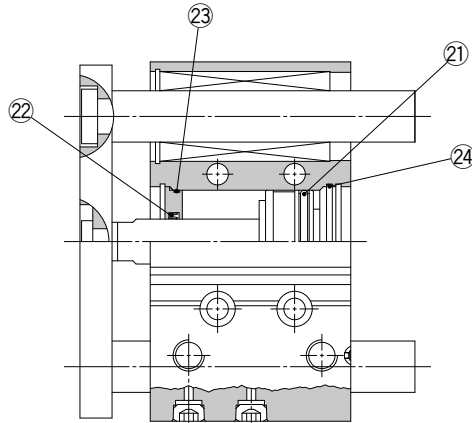

* The numbers are the same as the "Construction" of the MGP series catalog (CAT.ES20-219).
* Refer to pages 213-1 and 213-2 for replacement parts/seal kit and grease pack part numbers of Made-to-Order common specifications (-XB□, -XC□).

Seal Kit List

No.	Description	Material	Note
①	Piston seal	NBR	
②	Rod seal		
③	Gasket A		
④	Gasket B		

Replacement Parts: Seal Kit

Bore size (mm)	Kit no.	Contents	Bore size (mm)	Kit no.	Contents
12	MGP12-Z-PS	Set of left nos. ①, ②, ③, ④	40	MGP40-Z-PS	Set of left nos. ①, ②, ③, ④
16	MGP16-Z-PS		50	MGP50-Z-PS	
20	MGP20-Z-PS		63	MGP63-Z-PS	
25	MGP25-Z-PS		80	MGP80-Z-PS	
32	MGP32-Z-PS		100	MGP100-Z-PS	

* Seal kit includes ① to ④. Order the seal kit, based on each bore size.
* Since the seal kit does not include a grease pack, order it separately.
Grease pack part no.: GR-S-010 (10 g)

Actuators

Modular F.R.L.
Pressure Control Equipment

Air Preparation
Equipment

Industrial Filters

Replacement
Procedure

Actuators

Modular F.R.L.
Pressure Control Equipment

Industrial Filters

Series MGP-AZ

Replacement
Procedure is
P.333

Construction: Series MGPM-A, MGPL-A, MGPA-A

MGPM

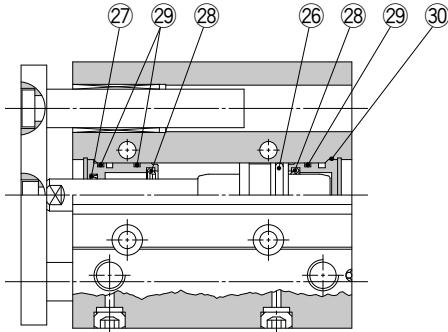

**MGPL
MGPA**

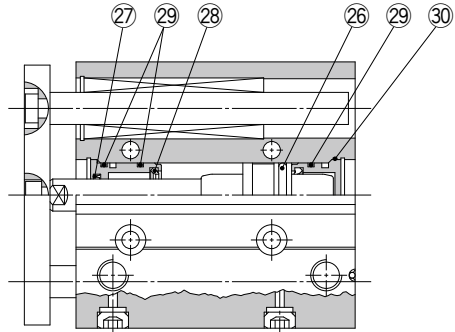

* The numbers are the same as the "Construction" of the MGP series catalog (CAT.ES20-219).

Seal Kit List

No.	Description	Material	Note
26	Piston seal	NBR	
27	Rod seal	NBR	
28	Cushion seal	Urethane	
29	Gasket A	NBR	
30	Gasket B	NBR	

Replacement Parts: Seal Kit

Bore size (mm)	Kit no.	Contents	Bore size (mm)	Kit no.	Contents
16	MGP16-AZ-PS	Set of left nos. 26, 27, 28, 29, 30	50	MGP50-AZ-PS	Set of left nos. 26, 27, 28, 29, 30
20	MGP20-AZ-PS		63	MGP63-AZ-PS	
25	MGP25-AZ-PS		80	MGP80-AZ-PS	
32	MGP32-AZ-PS		100	MGP100-AZ-PS	
40	MGP40-AZ-PS				

* Seal kit includes 26 to 30. Order the seal kit, based on each bore size.

* Since the seal kit does not include a grease pack, order it separately.

Grease pack part no.: GR-S-010 (10 g)

Actuators

Modular F.R.L.
Pressure Control Equipment

Air Preparation
Equipment

Industrial Filters

Replacement
Procedure

Actuators

Modular F.R.L.
Pressure Control Equipment

Industrial Filters

Series MGP

ø12, ø16, ø20, ø25, ø32
ø40, ø50, ø63, ø80, ø100



Construction

MGPM12 to 25

MGPM32 to 100

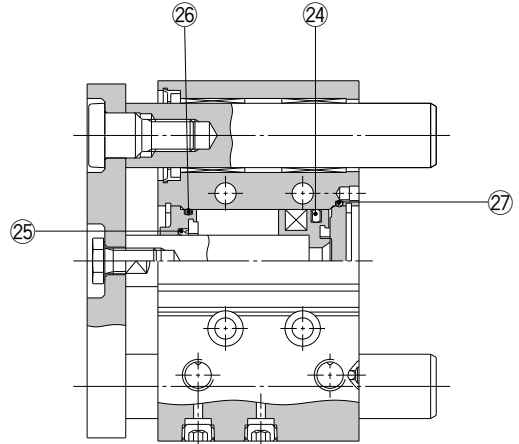
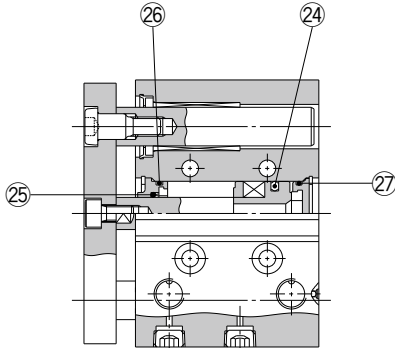

* The numbers are the same as the "Construction" of the Best Pneumatics No.3 Series MGP.
* Refer to pages 213-1 and 213-2 for replacement parts/seal kit and grease pack part numbers of Made-to-Order common specifications (-XB□, -XC□).

Seal Kit List

No.	Description	Material	Note
24	Piston seal	NBR	
25	Rod seal		
26	Gasket A		
27	Gasket B		

Replacement Parts: Seal Kit

Bore size (mm)	Kit no.	Contents
12	MGP12-PS	Set of left nos. 24, 25, 26, 27
16	MGP16-PS	
20	MGP20-PS	
25	MGP25-PS	
32	MGP32-PS	
40	MGP40-PS	
50	MGP50-PS	
63	MGP63-PS	
80	MGP80-PS	
100	MGP100-PS	

* Seal kit includes 24 to 27. Order the seal kit, based on each bore size.

* Since the seal kit does not include a grease pack, order it separately.

Grease pack part no.: GR-S-010 (10 g)

Series MGP

ø16, ø20, ø25, ø32,
ø40, ø50, ø63, ø80, ø100

Replacement
Procedure is
P.333

Construction

MGPM16 to 25

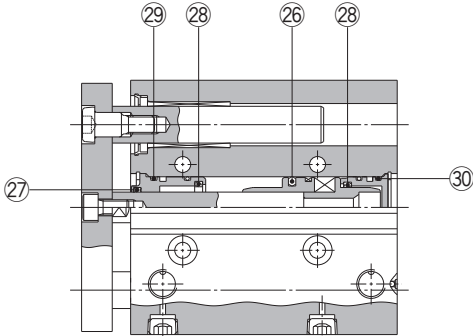

MGPM32 to 100

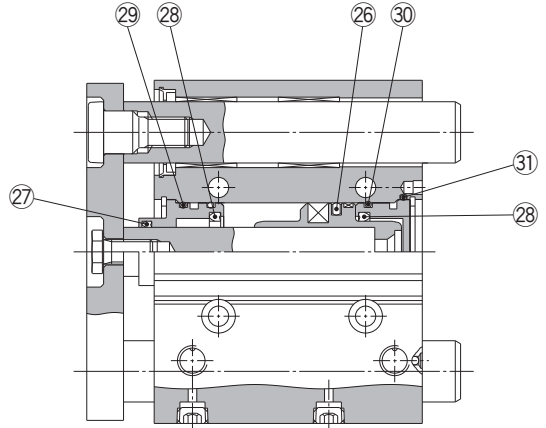

* The numbers are the same as the "Construction" of the Best Pneumatics No.3 Series MGP.

Seal Kit List

No.	Description	Material	Note
26	Piston seal	NBR	
27	Rod seal	NBR	
28	Cushion seal	Urethane	
29	Gasket A	NBR	
30	Gasket B	NBR	
31	Gasket C	NBR	

Replacement Parts: Seal Kit

Bore size (mm)	Kit no.	Contents
16	MGP16-A-PS	Set of left nos. 26, 27, 28, 29, 30, 31
20	MGP20-A-PS	
25	MGP25-A-PS	
32	MGP32-A-PS	
40	MGP40-A-PS	
50	MGP50-A-PS	
63	MGP63-A-PS	
80	MGP80-A-PS	
100	MGP100-A-PS	

* Seal kit includes 26 to 31. Order the seal kit, based on each bore size.

* Since the seal kit does not include a grease pack, order it separately.

Grease pack part no.: GR-S-010 (10 g)

Actuators

Modular F.R.L.
Pressure Control Equipment

Air Preparation
Equipment

Industrial Filters

Replacement
Procedure

Actuators

Modular F.R.L.
Pressure Control Equipment

Industrial Filters

Series MGP

ø20, ø25, ø32, ø40
ø50, ø63, ø80, ø100



Construction

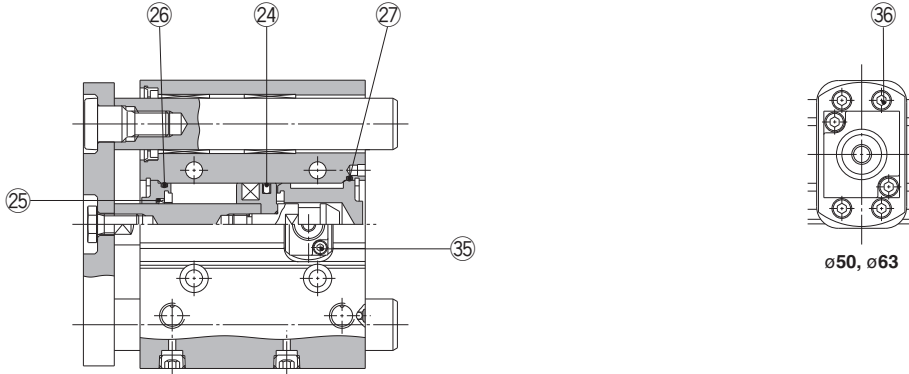

Non-locking type (Head end lock)

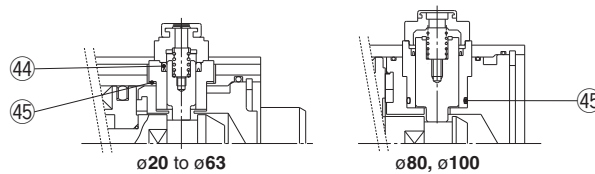

* The numbers are the same as the "Construction" of the Best Pneumatics No.3 Series MGP.

Seal Kit List

No.	Description	Material	Note
24	Piston seal	NBR	
25	Rod seal	NBR	
26	Gasket A	NBR	
27	Gasket B	NBR	
35	Hexagon socket head cap screw	Carbon steel	Black zinc chromated
36	Hexagon socket head cap screw	Carbon steel	Zinc chromated (ø50, ø63 only)
44	Lock piston seal	NBR	
45	Lock holder gasket	NBR	

Replacement Parts: Seal Kit

Bore size (mm)	Kit no.	Contents
20	MGP20-B-PS	Set of left nos. 24, 25, 26, 27, 35, 44, 45
25	MGP25-B-PS	
32	MGP32-B-PS	
40	MGP40-B-PS	
50	MGP50-B-PS	Set of left nos. 24, 25, 26, 27, 35, 36, 44, 45
63	MGP63-B-PS	
80	MGP80-B-PS	Set of left nos. 24, 25, 26, 27, 35, 44, 45
100	MGP100-B-PS	

* Each seal kit includes the parts listed above. Order the seal kit based on each bore size.

* Since the seal kit does not include a grease pack, order it separately.

Grease pack part no.: GR-S-010 (10 g)

Series MGPS

ø50, ø80

Replacement
Procedure is
p.333

Construction

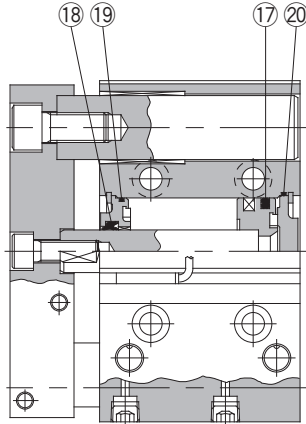

* The numbers are the same as the "Construction" of the Best Pneumatics No.3 Series MGPS.

Seal Kit List

No.	Description	Material	Note
17	Piston seal	NBR	
18	Rod seal		
19	Gasket A		
20	Gasket B		

Replacement Parts: Seal Kit

Bore size (mm)	Kit no.	Contents
50	MGP50-PS	Set of left nos.
80	MGP80-PS	17, 18, 19, 20

* Seal kit includes 17 to 20. Order the seal kit, based on each bore size.
 * Since the seal kit does not include a grease pack, order it separately.
Grease pack part no.: GR-S-010 (10 g)

Actuators

Modular F.R.L.
Pressure Control Equipment

Air Preparation
Equipment

Industrial Filters

Replacement
Procedure

Actuators

Modular F.R.L.
Pressure Control Equipment

Industrial Filters

Compact Guide Cylinder/Wide Type

Series MGPW

Replacement
Procedure is
p.333

Construction: Series MGPWM, MGPWL, MGPWA

MGPWM20 to 63

MGPWL20 to 63
MGPWA20 to 63

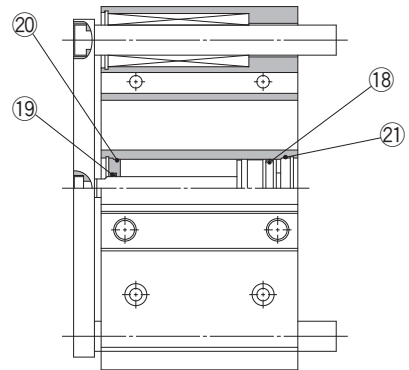
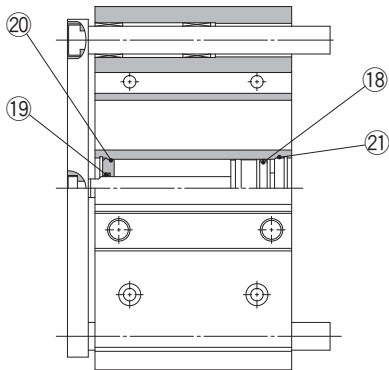

* The numbers are the same as the "Construction" of the MGPW series catalog (CAT.ES20-228).

Seal Kit List

No.	Description	Material	Note
18	Piston seal	NBR	
19	Rod seal		
20	Gasket A		
21	Gasket B		

Replacement Parts: Seal Kit

Bore size (mm)	Kit no.	Contents	Bore size (mm)	Kit no.	Contents
20	MGP20-Z-PS	Set of left nos.	40	MGP40-Z-PS	Set of left nos.
25	MGP25-Z-PS	18, 19,	50	MGP50-Z-PS	18, 19,
32	MGP32-Z-PS	20, 21	63	MGP63-Z-PS	20, 21

* Seal kit includes 18 to 21. Order the seal kit, based on each bore size.

* Since the seal kit does not include a grease pack, order it separately.

Grease pack part no.: GR-S-010 (10 g)

Series MGQ

ø12, ø16, ø20, ø25
ø32, ø40, ø50, ø63
ø80, ø100

Replacement
Procedure is
P.333

Construction

MGQM12 to 25

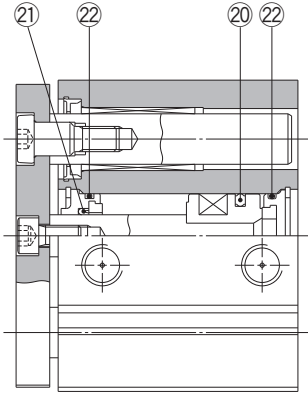

MGQM32 to 100

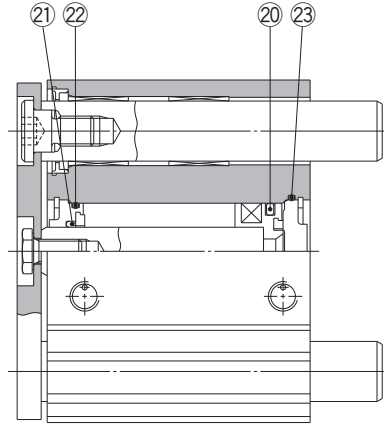

* The numbers are the same as the "Construction" of the Best Pneumatics No.3 Series MGQ.

Seal Kit List

No.	Description	Material	Note
20	Piston seal	NBR	
21	Rod seal		
22	Gasket A		
23	Gasket B		

Replacement Parts: Seal Kit

Bore size (mm)	Kit no.	Description
12	MGQ12-PS	Set of left nos. 20, 21, 22, 23
16	MGQ16-PS	
20	MGQ20-PS	
25	MGQ25-PS	
32	MGQ32-PS	
40	MGQ40-PS	
50	MGQ50-PS	
63	MGQ63-PS	
80	MGQ80-PS	
100	MGQ100-PS	

* Seal kit includes 20 to 23. Order the seal kit, based on each bore size.

* Since the seal kit does not include a grease pack, order it separately.

Grease pack part no.: GR-S-010 (10 g)

Actuators

Modular F.R.L.
Pressure Control Equipment

Air Preparation
Equipment

Industrial Filters

Replacement
Procedure

Actuators

Modular F.R.L.
Pressure Control Equipment

Industrial Filters

Series MGG

ø20, ø25, ø32, ø40, ø50

Construction

ø20 to ø50/MGG□□

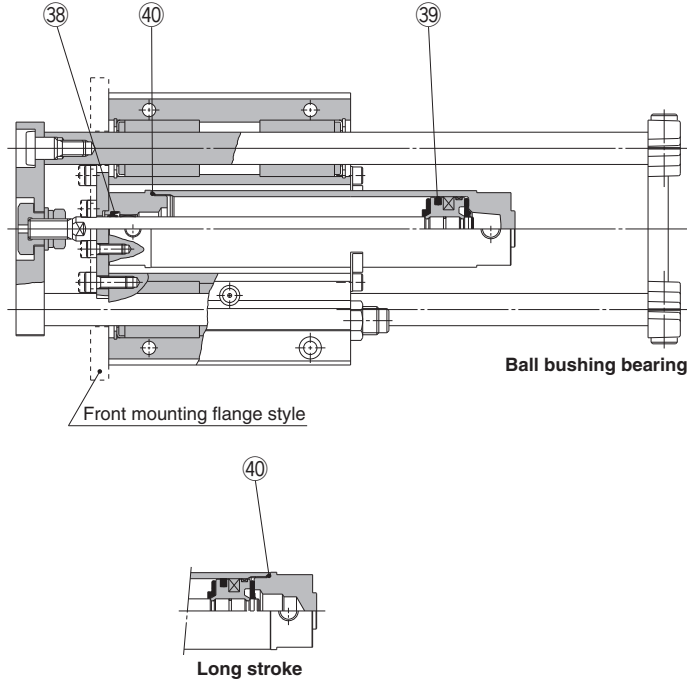

* The numbers are the same as the "Construction" of the Best Pneumatics No.3 Series MGG.

Seal Kit List

No.	Description	Material	Note
38	Rod seal	NBR	
39	Piston seal		
40	Tube gasket		

Replacement Parts: Seal Kit

Bore size (mm)	Kit no.	Contents
20	CG1N20-PS	Set of left nos. 38, 39, 40
25	CG1N25-PS	
32	CG1N32-PS	
40	CG1N40-PS	

* Seal kit includes 38 to 40. Order the seal kit, based on each bore size.

* Seal kit includes a grease pack (10 g).

Order with the following part number when only the grease pack is needed.

Grease pack part no.: GR-S-010 (10 g)

⚠ Caution

When disassembling cylinders with bore sizes of ø20 through ø40, grip the double flat part of either the tube cover or the rod cover with a vise and loosen the other side with a wrench or an adjustable angle wrench, and then remove the cover. When re-tightening, tighten approximately 2 degrees more than the original position.

(Cylinders with ø50 or larger bore sizes are tightened with a large tightening torque and cannot be disassembled. Please contact SMC when disassemble is required.)

Series MGG

ø63, ø80, ø100

Construction

ø63 to ø100/MGG□B

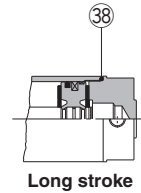
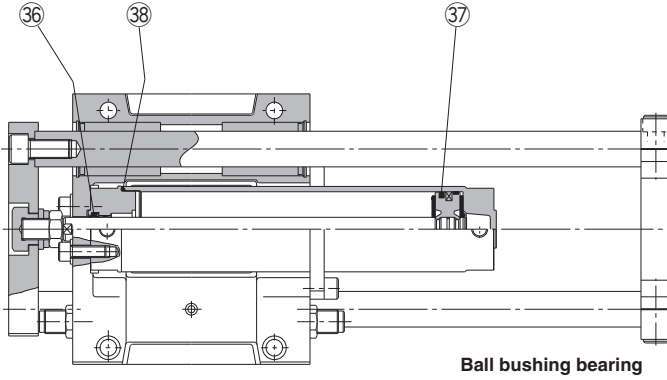

Long stroke

Ball bushing bearing

ø63 to ø100/MGG□F

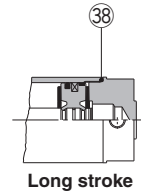
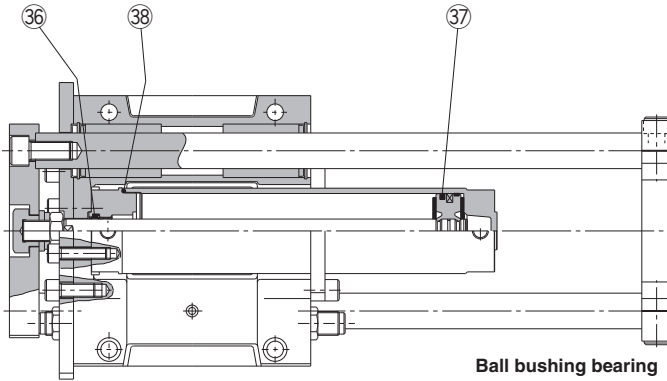

Long stroke

Ball bushing bearing

* The numbers are the same as the "Construction" of the Best Pneumatics No.3 Series MGG.

Seal Kit List

No.	Description	Material	Note
36	Rod seal	NBR	
37	Piston seal		
38	Tube gasket		

⚠ Caution

Basic cylinders with a bore size of ø50 cannot be disassembled. (Cylinders with ø50 or larger bore sizes are tightened with a large tightening torque and cannot be disassembled. Please contact SMC when disassemble is required.)

Series MGG

ø20, ø25, ø32, ø40
ø50, ø63, ø80, ø100

Construction

ø20 to ø100/MGG□□

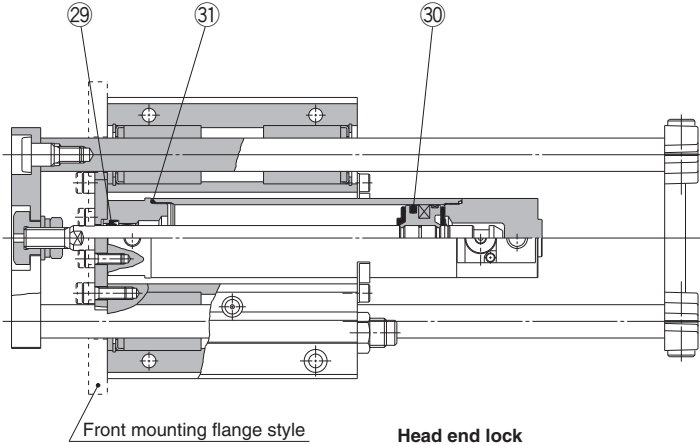

Manual release (Lock type)

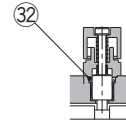

ø20 to ø63

* The numbers are the same as the "Construction" of the Best Pneumatics No.3 Series MGG.

Seal Kit List

No.	Description	Material	Note
29	Rod seal	NBR	
30	Piston seal		
31	Tube gasket		
32	Lock piston seal		

Replacement Parts: Seal Kit

Bore size (mm)	Kit no.	Contents
20	CBG1N20-PS	Set of left nos. 29, 30, 31, 32
25	CBG1N25-PS	
32	CBG1N32-PS	
40	CBG1N40-PS	

* Seal kit includes 29 to 32. Order the seal kit, based on each bore size.

* Seal kit includes a grease pack (10 g).

Order with the following part number when only the grease pack is needed.

Grease pack part no.: GR-S-010 (10 g)

⚠ Caution

Basic cylinders with a bore size of ø50 cannot be disassembled.

(Cylinders with ø50 or larger bore sizes are tightened with a large tightening torque and cannot be disassembled. Please contact SMC when disassemble is required.)

Construction: With Rear Plate

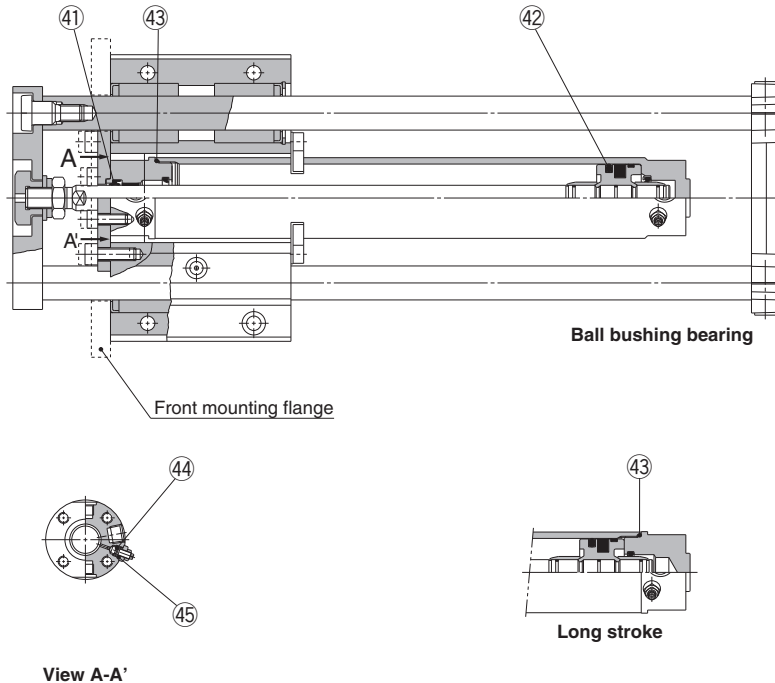

* The numbers are the same as the "Construction" of the Best Pneumatics No.3 Series MGC.

Seal Kit List

No.	Description	Material	Note
④①	Rod seal	NBR	
④②	Piston seal		
④③	Tube gasket		
④④	Valve seal		
④⑤	Valve retainer gasket		

Replacement Parts: Seal Kit

Bore size (mm)	Kit no.	Contents
20	CG1A20-PS	Set of left nos. ④①, ④②, ④③, ④④, ④⑤
25	CG1A25-PS	
32	CG1A32-PS	
40	CG1A40-PS	

* Seal kit includes ④① to ④⑤. Order the seal kit, based on each bore size.

* Seal kit includes a grease pack (10 g). Order with the following part number when only the grease pack is needed.

Grease pack part no.: GR-S-010 (10 g)

⚠ Caution

When disassembling base cylinders with bore sizes of ø20 through ø40, grip the double flat part of either the tube cover or the rod cover with a vise and loosen the other side with a wrench or an adjustable angle wrench, and then remove the cover. When retightening, tighten approximately 2 degrees more than the original position. (Cylinders with ø50 or larger bore sizes are tightened with a large tightening torque and cannot be disassembled. Please contact SMC when disassembly is required.)

Series MGF

ø40, ø63, ø100



Construction

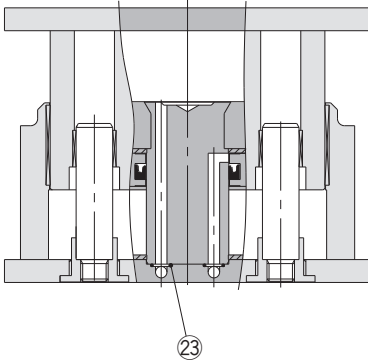

When the cylinder is extended

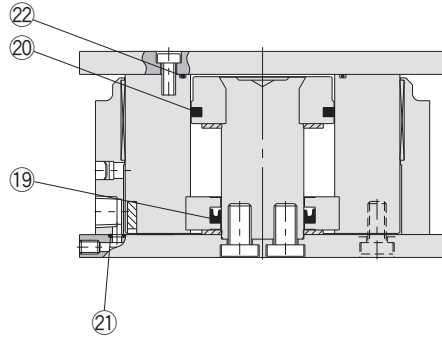

When the cylinder is retracted

* The numbers are the same as the "Construction" of the Best Pneumatics No.3 Series MGF.

Seal Kit List

No.	Description	Material	Note
19	Rod seal	NBR	
20	Piston seal		
21	O-ring A		
22	O-ring B		
23	O-ring C		

Replacement Parts: Seal Kit

Bore size (mm)	Kit no.	Contents
40	MGF 40-PS	Set of left nos. 19, 20, 21, 22, 23
63	MGF 63-PS	
100	MGF100-PS	

* Seal kit is not compatible with the clean series.
 Seal kit includes 19 to 23. Order the seal kit based on each bore size.
 * Since the seal kit does not include a grease pack, order it separately.
Grease pack part no.: GR-L-010 (10g)

Non-rotating Double Power Cylinder

Series MGZ

ø20, ø25, ø32, ø40
ø50, ø63, ø80

Construction

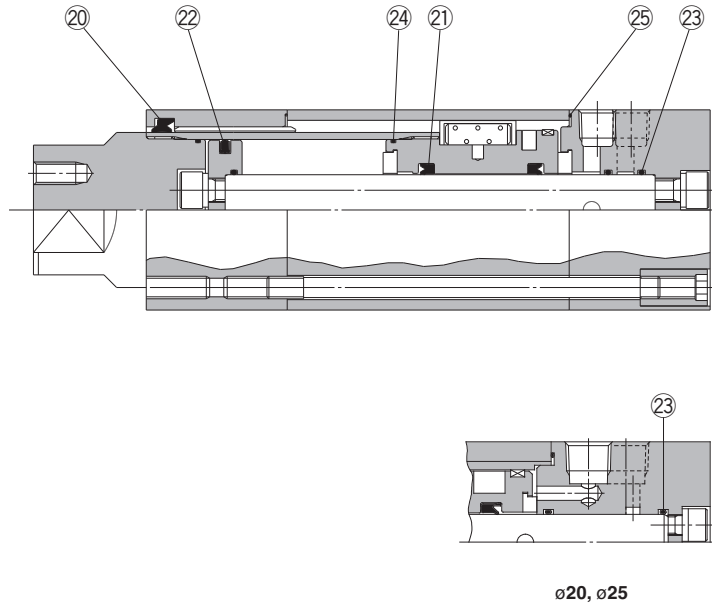

* The numbers are the same as the "Construction" of the Best Pneumatics No.3 Series MGZ.

Seal Kit List

No.	Description	Material	Note
20	Rod seal A	NBR	21, 22, 23 and 24 are non-replaceable parts, so they are not included in the seal kit.
21	Rod seal B		
22	Piston seal		
23	Piston gasket		
24	Tube rod gasket		
25	Cylinder tube gasket		

Replacement Parts: Seal Kit

Bore size (mm)	Kit no.	Contents
20	MGZ20-PS	Set of left nos. 20, 25
25	MGZ25-PS	
32	MGZ32-PS	
40	MGZ40-PS	
50	MGZ50-PS	
63	MGZ63-PS	
80	MGZ80-PS	

* Seal kits consist of items 20 and 25, and can be ordered by using the seal kit number corresponding to each bore size.

* Seal kit includes a grease pack (ø20 to ø50: 10 g, ø63, 80: 20 g). Order with the following part number when only the grease pack is needed.

Grease pack part no.: GR-S-010 (10 g), GR-S-020 (20 g)

Actuators

Modular F.R.L.
Pressure Control Equipment

Air Preparation
Equipment

Industrial Filters

Replacement
Procedure

Actuators

Modular F.R.L.
Pressure Control Equipment

Industrial Filters

Series MGZ ø40, ø50, ø63

Construction

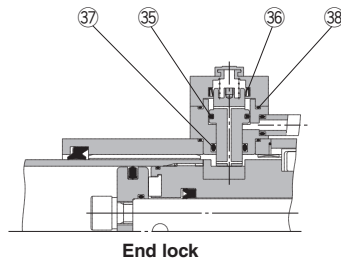
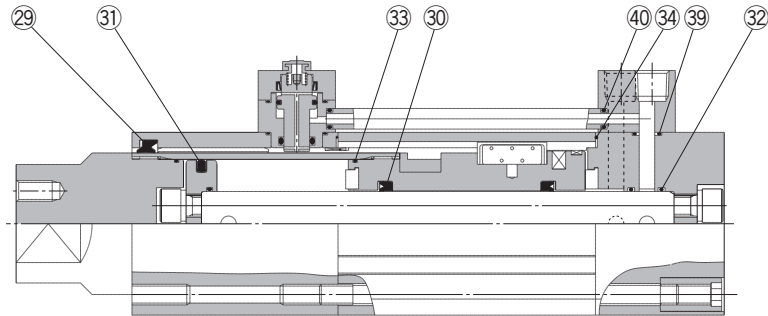

* The numbers are the same as the "Construction" of the Best Pneumatics No.3 Series MGZ.

Seal Kit List

No.	Description	Material	Note
29	Rod seal A	NBR	30, 31, 32 and 33 are non-replaceable parts, so they are not included in the seal kit.
30	Rod seal B		
31	Piston seal		
32	Piston gasket		
33	Tube rod gasket		
34	Cylinder tube gasket		
35	Locking piston seal A		
36	Locking piston seal B		
37	Locking piston seal C		
38	Lock holder gasket		
39	Port block gasket		
40	Pipe gasket		

Replacement Parts: Seal Kit

Bore size (mm)	Kit no.	Contents
40	MGZ40R-PS	Set of left nos. 29, 34, 35, 36, 37, 38, 39, 40
50	MGZ50R-PS	
63	MGZ63R-PS	

* Seal kits consist of items 29 and 34 to 40, and can be ordered by using the seal kit number corresponding to each bore size.

* Seal kit includes a grease pack (10 g).

Order with the following part number when only the grease pack is needed.

Grease pack part no.: GR-S-010 (10 g)

Series MGZR

ø20, ø25, ø32, ø40
ø50, ø63, ø80

Construction

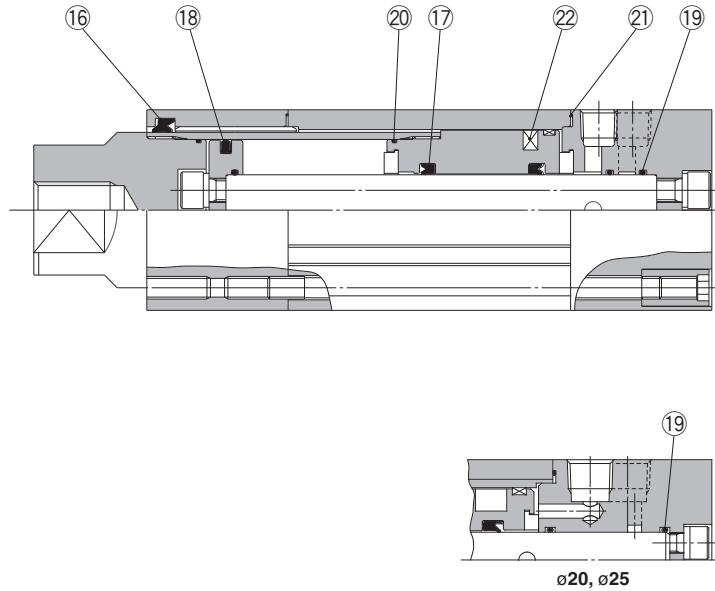

* The numbers are the same as the "Construction" of the Best Pneumatics No.3 Series MGZR.

Seal Kit List

No.	Description	Material	Note
①⑥	Rod seal A	NBR	17, 18, 19 and 20 are non-replaceable parts, so they are not included in the seal kit.
17	Rod seal B		
18	Piston seal		
19	Piston gasket		
20	Tube rod gasket		
②①	Cylinder tube gasket		

Replacement Parts: Seal Kit

Bore size (mm)	Kit no.	Contents
20	MGZ20-PS	Set of left nos. ①⑥, ②①
25	MGZ25-PS	
32	MGZ32-PS	
40	MGZ40-PS	
50	MGZ50-PS	
63	MGZ63-PS	
80	MGZ80-PS	

* Seal kits consist of items ①⑥ and ②①, and can be ordered by using the seal kit number corresponding to each bore size.

* Seal kit includes a grease pack (ø20 to ø50: 10 g, ø63, 80: 20 g). Order with the following part number when only the grease pack is needed.

Grease pack part no.: GR-S-010 (10 g), GR-S-020 (20 g)

Actuators

Modular F.R.L.
Pressure Control Equipment

Air Preparation
Equipment

Industrial Filters

Replacement
Procedure

Actuators

Modular F.R.L.
Pressure Control Equipment

Industrial Filters

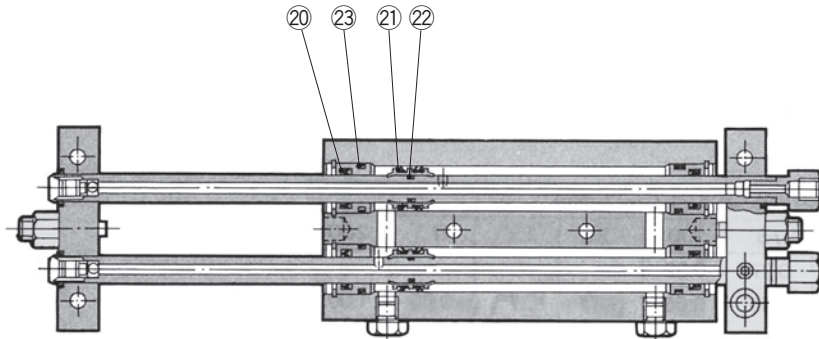
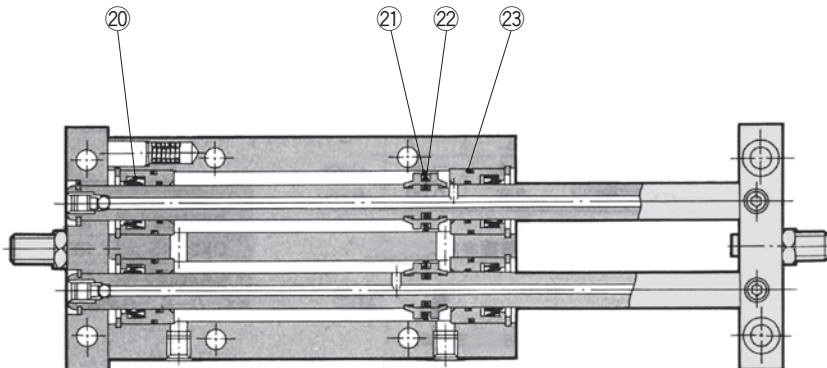
Construction**CX2N10****CX2N15, 25**

* The numbers are the same as the "Construction" of the Best Pneumatics No.3 Series CX2.

Seal Kit List

No.	Description	Material	Note
②①	Rod seal	NBR	22 is a non-replaceable part, so it is not included in the seal kit.
②②	Piston seal		
②③	Piston gasket		
②④	Cylinder tube gasket		

Replacement Parts: Seal Kit

Model	Kit no.	Contents
CX2N10	CX2N10-PS	Set of left nos. ②①, ②②, ②③
CX2N15	CX2N15-PS	
CX2N25	CX2N25-PS	

* Seal kit includes ②①, ②②, ②③. Order the seal kit, based on each bore size. (The piston gasket ②③ is not replaceable.)

* Since the seal kit does not include a grease pack, order it separately.
Grease pack part no.: GR-S-010 (10 g)

Series CXWM

ø10, ø16, ø25

Construction

ø10

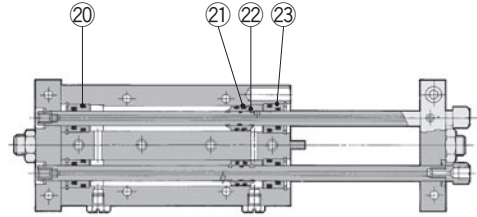
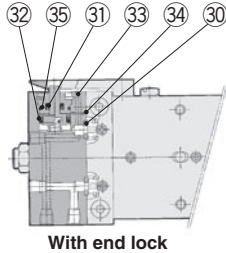

ø16, ø25

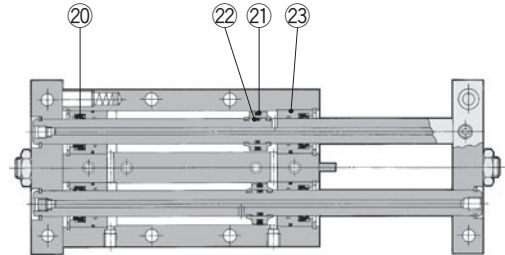
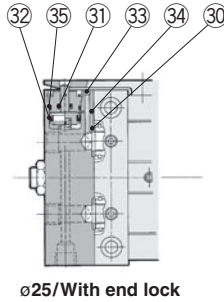
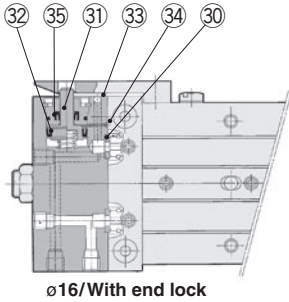

* The numbers are the same as the "Construction" of the Best Pneumatics No.3 Series CXWM.

Seal Kit List

No.	Description	Material	Note
20	Rod seal	NBR	22 is a non-replaceable part, so it is not included in the seal kit.
21	Piston seal	NBR	
22	Piston gasket	NBR	
23	Cylinder tube gasket	NBR	

With End Lock

30	Body gasket	NBR	33 and 34 are non-replaceable parts, so they are not included in the seal kit.
31	Rod seal	NBR	
32	Piston seal	NBR	
33	Steel ball	High carbon chrome bearing steel	
34	Steel ball	High carbon chrome bearing steel	
35	O-ring	NBR	

Replacement Parts: Seal Kit

Model	Kit no.	Contents
Cylinder body		
CXWM10	CXWM10-PS	Set of left nos. 20, 21, 23
CXWM16	CXWM16-PS	
CXWM25	CXWM25-PS	

* Seal kit includes 20, 21, 23. Order the seal kit, based on each bore size. (The piston gasket 22 is not replaceable.)

* Since the seal kit does not include a grease pack, order it separately. Grease pack part no.: GR-S-010 (10 g)

End lock

CXWM10	CXWM10R-PS	Set of left nos. 30, 31, 32, 35
CXWM16	CXWM16R-PS	
CXWM25	CXWM25R-PS	

* Seal kit includes 30, 31, 32, 35. Order the seal kit, based on each bore size.

* Since the seal kit does not include a grease pack, order it separately. Grease pack part no.: GR-S-010 (10 g)

Actuators

Modular F.R.L.
Pressure Control Equipment

Air Preparation
Equipment

Industrial Filters

Replacement
Procedure

Actuators

Modular F.R.L.
Pressure Control Equipment

Industrial Filters

Series CXWM ø20, ø32

Construction

ø20, ø32

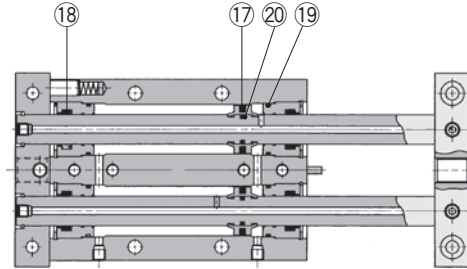

With end lock

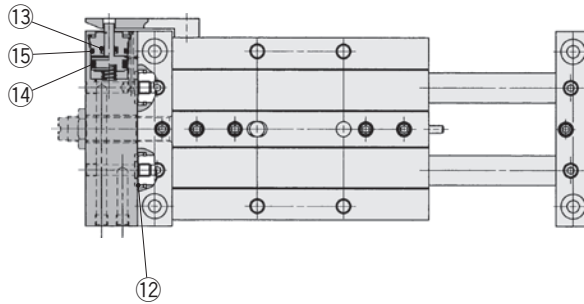

* The numbers are the same as the "Construction" of the Best Pneumatics No.3 Series CXWM.

Seal Kit List

No.	Description	Material	Note
17	Piston seal	NBR	20 is a non-replaceable part, so it is not included in the seal kit.
18	Rod seal		
19	Cylinder tube gasket		
20	Piston gasket		

With End Lock

No.	Description	Material	Note
12	Body gasket	NBR	
13	Rod seal		
14	Piston seal		
15	O-ring		

Replacement Parts: Seal Kit

Model	Kit no.	Contents
Cylinder body		
CXWM20	CXWM20-PS	Set of left nos.
CXWM32	CXWM32-PS	17, 18, 19

* Seal kit includes 17, 18, 19. Order the seal kit, based on each bore size. (The piston gasket 20 is not replaceable.)

* Since the seal kit does not include a grease pack, order it separately.

Grease pack part no.: GR-S-010 (10 g)

End lock

Model	Kit no.	Contents
CXWM20	CXWM20R-PS	Set of left nos.
CXWM32	CXWM32R-PS	12, 13, 14, 15

* Seal kit includes 12, 13, 14, 15. Order the seal kit, based on each bore size.

* Since the seal kit does not include a grease pack, order it separately.

Grease pack part no.: GR-S-010 (10 g)

Series CXWL

Ball Bushing Bearing Type:
 $\varnothing 10$, $\varnothing 16$, $\varnothing 25$

Construction

$\varnothing 10$

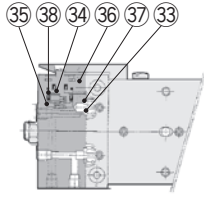

With end lock

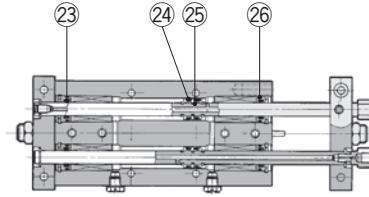

$\varnothing 16$

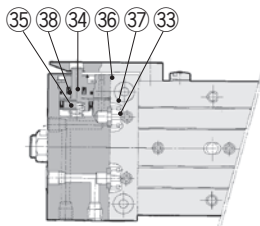

With end lock

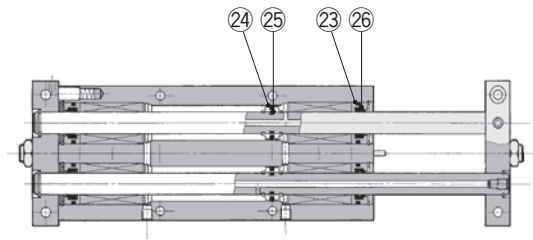

$\varnothing 25$

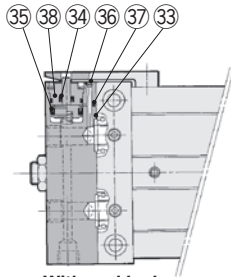

With end lock

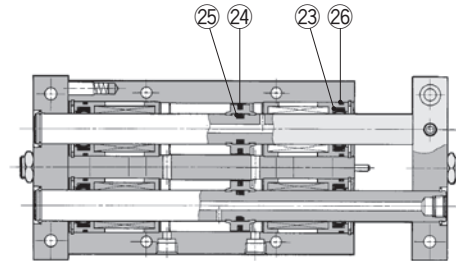

* The numbers are the same as the "Construction" of the Best Pneumatics No.3 Series CXWL.

Seal Kit List

No.	Description	Material	Note
23	Rod seal	NBR	25 is a non-replaceable part, so it is not included in the seal kit.
24	Piston seal		
25	Piston gasket		
26	Cylinder tube gasket		

With End Lock

33	Body gasket	NBR	36 and 37 are non-replaceable parts, so they are not included in the seal kit.
34	Rod seal	NBR	
35	Piston seal	NBR	
36	Steel ball	High carbon chrome bearing steel	
37	Steel ball	High carbon chrome bearing steel	
38	O-ring	NBR	

Replacement Parts: Seal Kit

Model	Kit no.	Contents
Cylinder body		
CXWL10	CXWL10-PS	Set of left nos. 23, 24, 26
CXWL16	CXWL16-PS	
CXWL25	CXWL25-PS	

* Seal kit includes 23, 24 and 26. Order the seal kit with the part number for each model.

* 25 is not replaceable.

* Since the seal kit does not include a grease pack, order it separately.

Grease pack part no.: GR-S-010 (10 g)

End lock

CXWL10	CXWL10R-PS	Set of left nos. 33, 34, 35, 38
CXWL16	CXWL16R-PS	
CXWL25	CXWL25R-PS	

* Seal kit includes 33, 34, 35 and 38. Order the seal kit with the part number for each model.

* Since the seal kit does not include a grease pack, order it separately.

Grease pack part no.: GR-S-010 (10 g)

Actuators

Modular F.R.L.
Pressure Control Equipment

Air Preparation
Equipment

Industrial Filters

Replacement
Procedure

Actuators

Modular F.R.L.
Pressure Control Equipment

Industrial Filters

Series CXWL

Ball Bushing Bearing Type:
 $\varnothing 20$, $\varnothing 32$

Construction

$\varnothing 20$

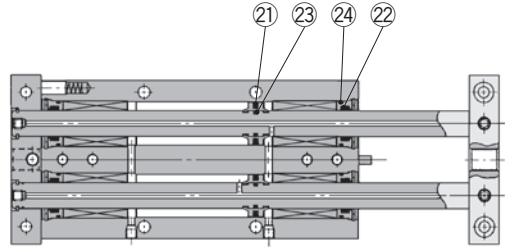
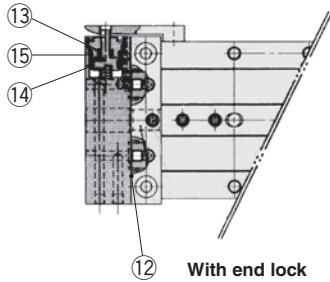

$\varnothing 32$

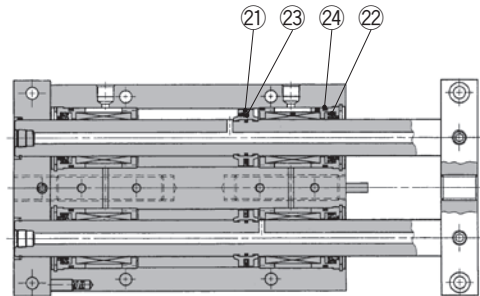
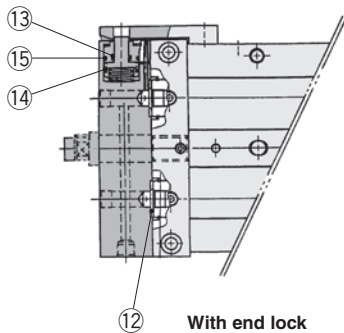

* The numbers are the same as the "Construction" of the Best Pneumatics No.3 Series CXWL.

Seal Kit List

No.	Description	Material	Note
①	Piston seal	NBR	23 is a non-replaceable part, so it is not included in the seal kit.
②	Rod seal		
23	Piston gasket		
④	Cylinder tube gasket		

With end lock

12	Body gasket	NBR
13	Rod seal	
14	Piston seal	
15	O-ring	

Replacement Parts: Seal Kit

Model	Kit no.	Contents
CXWL20	CXWL20-PS	Set of left nos. ①, ②, ④
CXWL32	CXWL32-PS	①, ②, ④

* Seal kit includes ①, ② and ④. Order the seal kit with the part number for each model.

* 23 is not replaceable.

* Since the seal kit does not include a grease pack, order it separately.

Grease pack part no.: GR-S-010 (10 g)

End lock

CXWL20	CXWL20R-PS	Set of left nos. 12, 13, 14, 15
CXWL32	CXWL32R-PS	12, 13, 14, 15

* Seal kit includes 12, 13, 14 and 15. Order the seal kit with the part number for each model.

* Since the seal kit does not include a grease pack, order it separately.

Grease pack part no.: GR-S-010 (10 g)

Series CXT

ø12, ø16, ø20,
ø25, ø32, ø40

Replacement
Procedure is
P.290

Construction

CXTM
Guide rod/bearing

CXTL
Guide rod/bearing

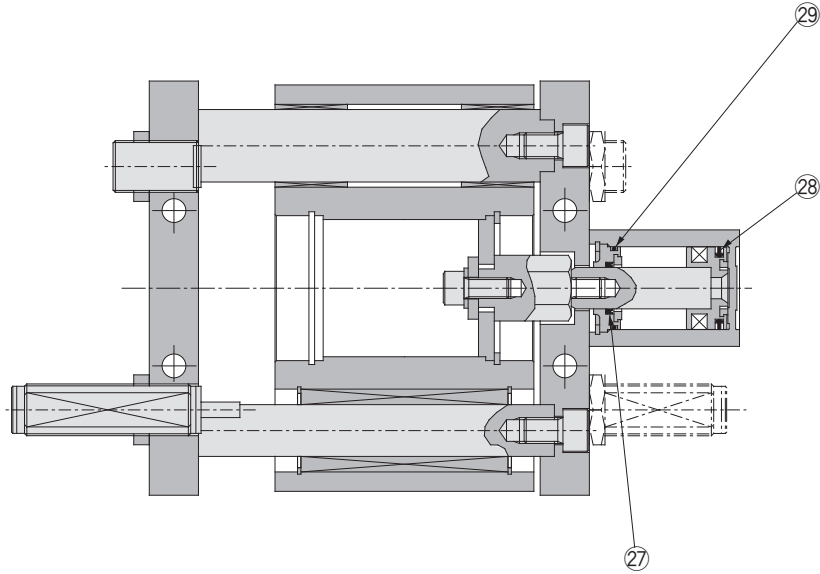

* The numbers are the same as the "Construction" of the Best Pneumatics No.3 Series CXT.

Seal Kit List

No.	Description	Material	Note
27	Rod seal	NBR	
28	Piston seal		
29 ^{Note)}	Tube gasket		

Note) The same type of the part is equipped to the head side for the long stroke type.

Replacement Parts: Seal Kit

Model	Cylinder	Kit no
Standard stroke		
CXT□12	CDQSB12	CQSB12-PS
CXT□16	CDQSB16	CQSB16-PS
CXT□20	CDQSB20	CQSB20-PS
CXT□25	CDQSB25	CQSB25-PS
CXT□32	CDQ2A32	CQ2B32-PS
CXT□40	CDQ2A40	CQ2B40-PS
Long stroke		
CXT□12	CDQSB12	CQSB12-L-PS
CXT□16	CDQSB16	CQSB16-L-PS
CXT□20	CDQSB20	CQSB20-L-PS
CXT□25	CDQSB25	CQSB25-L-PS
CXT□32	CDQ2A32	CQ2A32-L-PS
CXT□40	CDQ2A40	CQ2A40-L-PS

* Seal kit includes 27, 28 and 29. Order the seal kit with the kit number.

* Since the seal kit does not include a grease pack, order it separately.

Grease pack part no.: GR-S-010 (10 g)

Actuators

Modular F.R.L.
Pressure Control Equipment

Air Preparation
Equipment

Industrial Filters

Replacement
Procedure

Actuators

Modular F.R.L.
Pressure Control Equipment

Industrial Filters

Series CXSJ

ø6, ø10, ø15, ø20
ø25, ø32

Replacement
Procedure is
P.339

Construction

CXSJM (Slide bearing)
CXSJM6

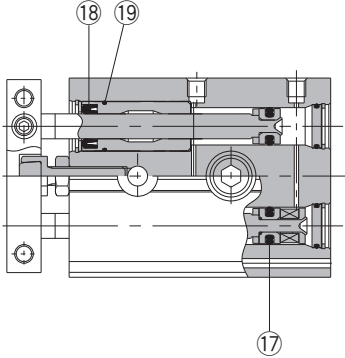

CXSJM15

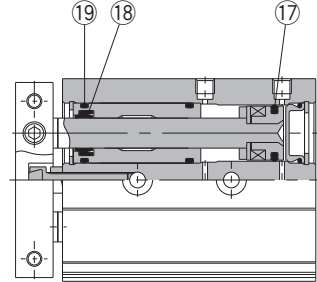

CXSJM10

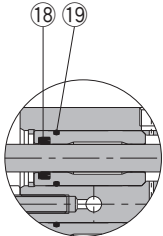

Rod cover

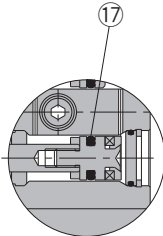

Piston rod B-side piston

CXSJM20 to 32

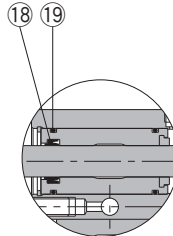

Rod cover

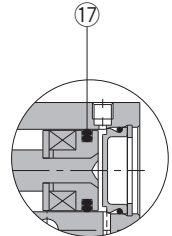

Head cover

* The numbers are the same as the "Construction" of the Best Pneumatics No.3 Series CXSJ.

Seal Kit List

No.	Description	Material	Note
17	Piston seal	NBR	
18	Rod seal		
19	O-ring		

Replacement Parts: Seal Kit

Model	Seal kit no.	Contents
CXSJM6	CXSJM6-PS	Set of left nos. 17, 18, 19
CXSJM10	CXSJM10-PS	
CXSJM15	CXSM15-PS	
CXSJM20	CXSM20-PS	
CXSJM25	CXSM25-PS	
CXSJM32	CXSM32-PS	

* Seal kit includes 17, 18, and 19. Order the seal kit, based on each bore size.

* Since the seal kit does not include a grease pack, order it separately.

Grease pack part no.: GR-S-010 (10 g)

Series CXSJ

ø6, ø10, ø15, ø20
ø25, ø32

Replacement
Procedure is
P.339

Construction

CXSJL (Ball bushing bearing)
CXSJL6

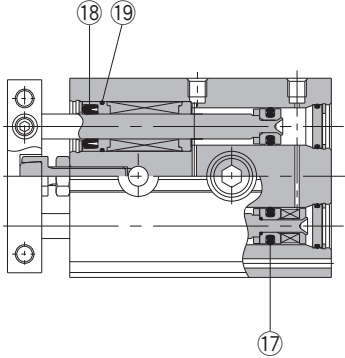

CXSJL15

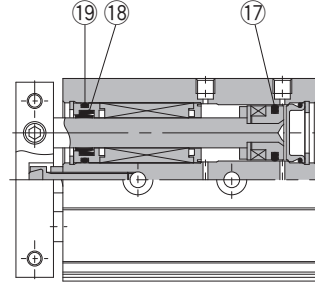

CXSJL10

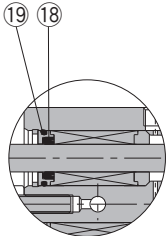

Rod cover

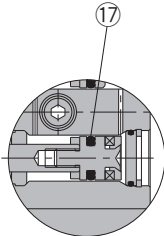

Piston rod B-side piston

CXSJL20 to 32

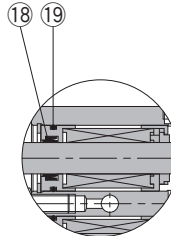

Rod cover

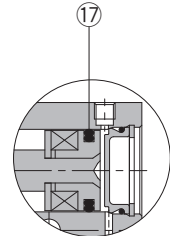

Head cover

* The numbers are the same as the "Construction" of the Best Pneumatics No.3 Series CXSJ.

Seal Kit List

No.	Description	Material	Note
⑰	Piston seal	NBR	
⑱	Rod seal		
⑲	O-ring		

Replacement Parts: Seal Kit

Model	Seal kit no.	Contents
CXSJL6	CXSJL6-PS	Set of left nos. ⑰, ⑱, ⑲
CXSJL10	CXSJL10-PS	
CXSJL15	CXSL15APS	
CXSJL20	CXSL20APS	
CXSJL25	CXSL25APS	
CXSJL32	CXSL32APS	

* Seal kit includes ⑰, ⑱, and ⑲. Order the seal kit, based on each bore size.

* Since the seal kit does not include a grease pack, order it separately.
Grease pack part no.: GR-S-010 (10 g)

Actuators

Modular F.R.L.
Pressure Control Equipment

Air Preparation
Equipment

Industrial Filters

Replacement
Procedure

Actuators

Modular F.R.L.
Pressure Control Equipment

Industrial Filters

Series CXS

ø6, ø10, ø15, ø20, ø25, ø32



Construction

CXSM6

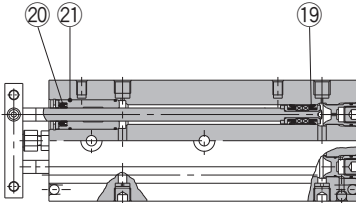

CXSM10

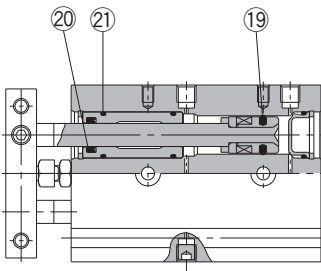

CXSM15

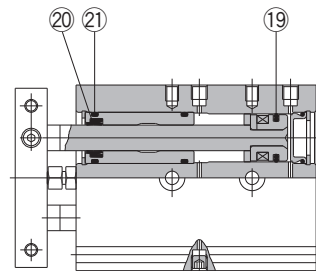

CXSM20 to 32

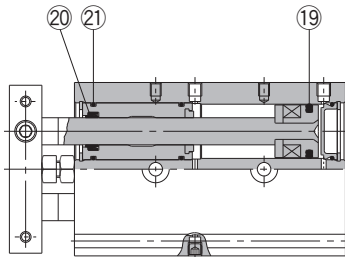

* The numbers are the same as the "Construction" of the Best Pneumatics No.3 Series CXS.

Seal Kit List

No.	Description	Material	Note
①9	Piston seal	NBR	
②0	Rod seal		
②1	O-ring		

Replacement Parts: Seal Kit

Bore size (mm)	Kit no.	Contents
6	CXSM 6-PS	Set of left nos. ①9, ②0, ②1
10	CXSM 10 A PS	
15	CXSM 15-PS	
20	CXSM 20-PS	
25	CXSM 25-PS	
32	CXSM 32-PS	

* Seal kit includes ①9, ②0 and ②1. Order the seal kit, based on each bore size.

* Since the seal kit does not include a grease pack, order it separately.

Grease pack part no.: GR-S-010 (10 g)

Dual Rod Cylinder/Basic Type: Ball Bushing Bearing

Series CXS

ø6, ø10, ø15, ø20, ø25, ø32

Replacement
Procedure is
P.339

Construction

CXSL6

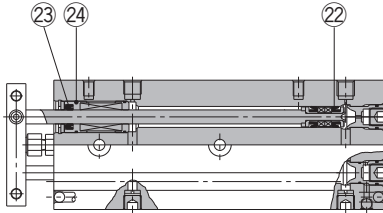

CXSL10

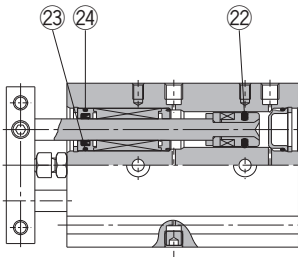

CXSL15

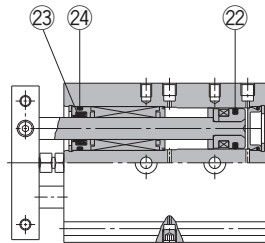

CXSL20 to 32

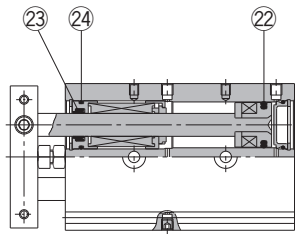

* The numbers are the same as the "Construction" of the Best Pneumatics No.3 Series CXS.

Seal Kit List

No.	Description	Material	Note
22	Piston seal	NBR	
23	Rod seal		
24	O-ring		

Replacement Parts: Seal Kit

Bore size (mm)	Kit no.	Contents
6	CXSL 6 - PS	Set of left nos. 22, 23, 24
10	CXSL 10 B PS	
15	CXSL 15 A PS	
20	CXSL 20 A PS	
25	CXSL 25 A PS	
32	CXSL 32 A PS	

* Seal kit includes 22, 23 and 24. Order the seal kit, based on each bore size.

* Since the seal kit does not include a grease pack, order it separately.
Grease pack part no.: GR-S-010 (10 g)

Actuators

Modular F.R.L.
Pressure Control Equipment

Air Preparation
Equipment

Industrial Filters

Replacement
Procedure

Actuators

Modular F.R.L.
Pressure Control Equipment

Industrial Filters

Dual Rod Cylinder/With Air Cushion

Series CXS

ø20, ø25, ø32

Replacement
Procedure is
P.339

Construction

CXSM/With air cushion

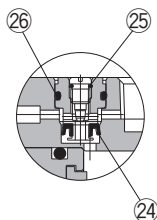
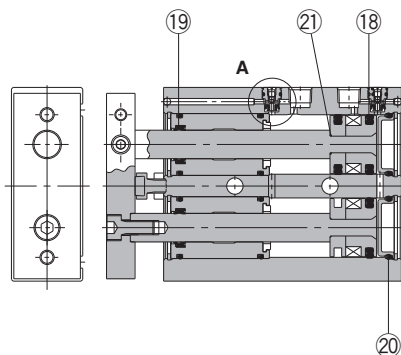

Close-up of A

CXSL/With air cushion

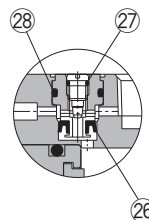
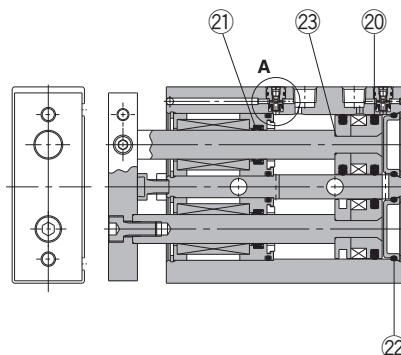

Close-up of A

* The numbers are the same as the "Construction" of the Best Pneumatics No.3 Series CXS.

Seal Kit List

No.	Description	Material	Note
18	Piston seal	NBR	21 and 24 to 26 are non-replaceable parts, so they are not included in the seal kit.
19	Rod seal		
20	O-ring		
21	O-ring		
24	Check seal		
25	Needle gasket		
26	Check gasket		

Replacement Parts: Seal Kit

Bore size (mm)	Kit no.	Contents
20	CXSM20A-PS	Set of nos. above 18, 19, 20
25	CXSM25A-PS	
32	CXSM32A-PS	

* Seal kit includes 18, 19 and 20. Order the seal kit, based on each bore size.

* Since the seal kit does not include a grease pack, order it separately.
Grease pack part no.: GR-S-010 (10 g)

Seal Kit List

No.	Description	Material	Note
20	Piston seal	NBR	23 and 26 to 28 are non-replaceable parts, so they are not included in the seal kit.
21	Rod seal		
22	O-ring		
23	O-ring		
26	Check seal		
27	Needle gasket		
28	Check gasket		

Replacement Parts: Seal Kit

Bore size (mm)	Kit no.	Contents
20	CXSL20A-PS	Set of nos. above 20, 21, 22
25	CXSL25A-PS	
32	CXSL32A-PS	

* Seal kit includes 20, 21 and 22. Order the seal kit, based on each bore size.

* Since the seal kit does not include a grease pack, order it separately.
Grease pack part no.: GR-S-010 (10 g)

Series CXS

ø6, ø10, ø15, ø20, ø25, ø32

Replacement Procedure is P.339

Construction

CXSM6

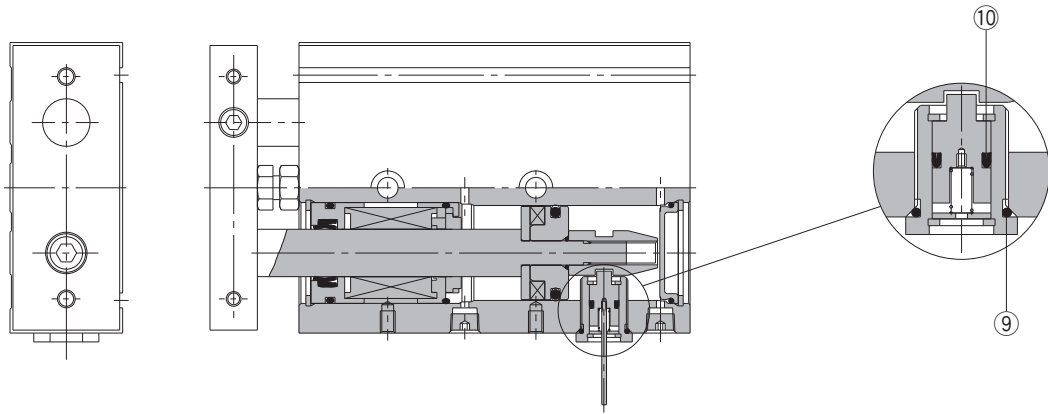

* The numbers are the same as the "Construction" of the Best Pneumatics No.3 Series CXS.

Seal Kit List

No.	Description	Material	Note
⑨	O-ring	NBR	
⑩	Rod seal		

Replacement Parts: Seal Kit

Bore size (mm)	Kit no.	Contents
6	CXSRM6-PS	Includes the kit components of the seal kit featured on page 149 plus items ⑨ and ⑩ from the left parts list.
	CXSRL6APS	
10	CXSRM10-PS	
	CXSRL10APS	
15	CXSRM15-PS	
	CXSRL15APS	
20	CXSRM20-PS	
	CXSRL20APS	
25	CXSRM25-PS	
	CXSRL25APS	
32	CXSRM32-PS	
	CXSRL32APS	

* Seal kits includes the basic type seal (page 149), ⑨ and ⑩. Order the seal kit, based on each bore size.

* Since the seal kit does not include a grease pack, order it separately.

Grease pack part no.:GR-S-010 (10 g)

Actuators

Modular F.R.L.
Pressure Control Equipment

Air Preparation
Equipment

Industrial Filters

Replacement
Procedure

Actuators

Modular F.R.L.
Pressure Control Equipment

Industrial Filters

Dual Rod Cylinder/Double Rod Type

Series CXSW

ø6, ø10, ø15
ø20, ø25, ø32



Construction

CXSWM/Slide bearing

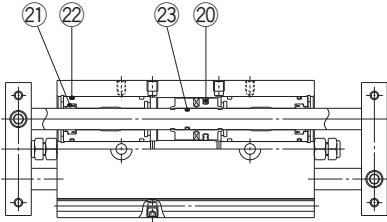

CXSWL/Ball bushing bearing

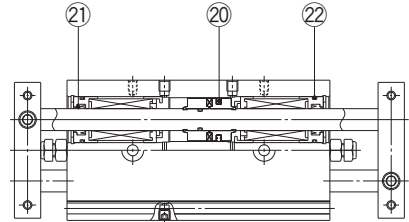

* The numbers are the same as the "Construction" of the Best Pneumatics No.3 Series CXSW.

Seal Kit List

No.	Description	Material	Note
20	Piston seal	NBR	23 is a non-replaceable part, so it is not included in the seal kit.
21	Rod seal		
22	O-ring		
23	O-ring		

Replacement Parts: Seal Kit

Bore size (mm)	Kit no.	Contents
6	CXSWM6-PS	Set of left nos. 20, 21, 22
	CXSWL6-PS	
10	CXSWM10-PS	
	CXSWL10APS	
15	CXSWM15-PS	
	CXSWL15APS	
20	CXSWM20-PS	
	CXSWL20APS	
25	CXSWM25-PS	
	CXSWL25APS	
32	CXSWM32-PS	
	CXSWL32APS	

* Seal kit includes 20 to 22. To order them, use the order number given in the left table.

* Since the seal kit does not include a grease pack, order it separately.

Grease pack part no.: GR-S-010 (10 g)

Series CLG1

ø20, ø25, ø32, ø40

Replacement Procedure is p.340

Construction

With rubber bumper: CLG1BN

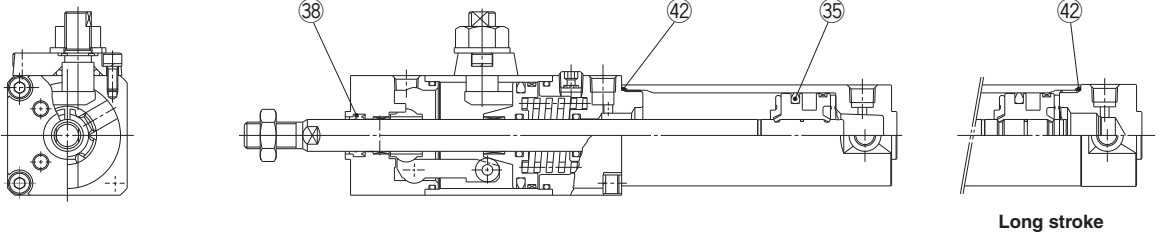

With air cushion: CLG1BA

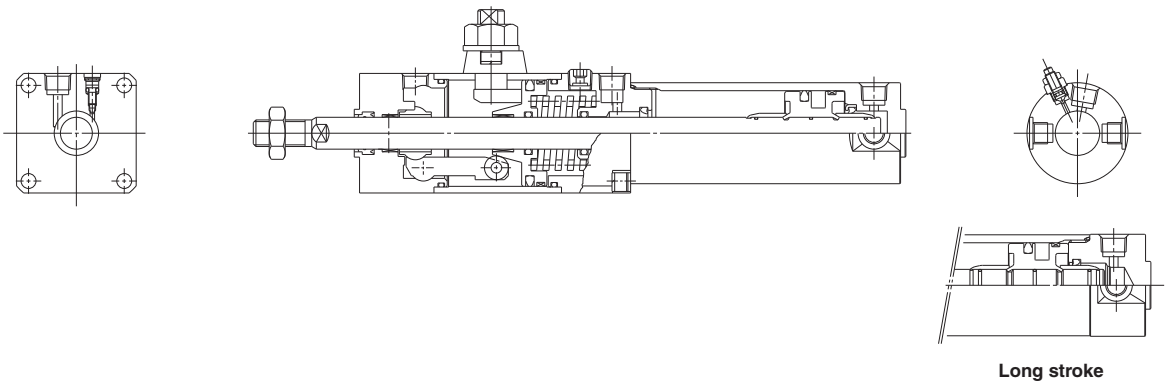

* The numbers are the same as the "Construction" of the Best Pneumatics No.3 Series CLG1.

Seal Kit List

No.	Description	Material	Note
35	Piston seal	NBR	
38	Rod seal B		
42	Cylinder tube gasket		

Replacement Parts: Seal Kit

Bore size (mm)	Kit no.	Contents
20	CG1N20-PS	Set of left nos. 35, 38, 42
25	CG1N25-PS	
32	CG1N32-PS	
40	CG1N40-PS	

* Since the lock section for Series CLG1 is normally replaced as a unit, kits are for the cylinder section only. These can be ordered using the order number for each bore size.

* Seal kit includes a grease pack (10 g).

Order with the following part number when only the grease pack is needed.

Grease pack part no.: GR-S-010 (10 g)

Replacement Parts: Lock Unit

CLG1B **N** 40 **TN** - **E**

Cushion Type

N	Rubber bumper
A	Air cushion

Bore size (mm)

Lock operation

E	Spring locking (Exhaust locking)
P	Pneumatic locking (Pressure locking)
D	Spring and pneumatic locking

Port thread type

Nil	Rc
TN	NPT

Lock-up Cylinder/Double Acting, Single Rod

Series CL1

ø40, ø50, ø63, ø80, ø100
ø125, ø140, ø160

Replacement
Procedure is
p.343

Construction

ø40 to ø100

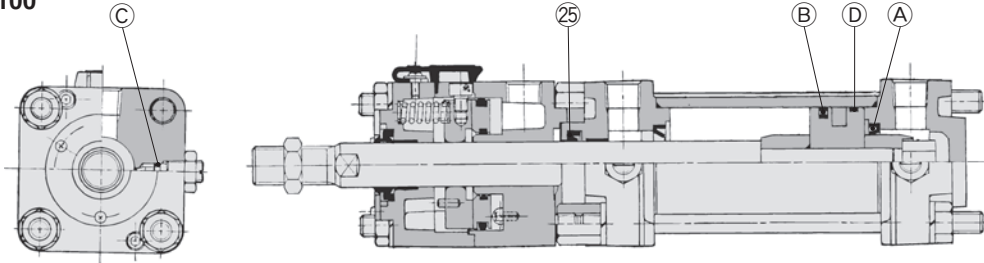

ø125 to ø160

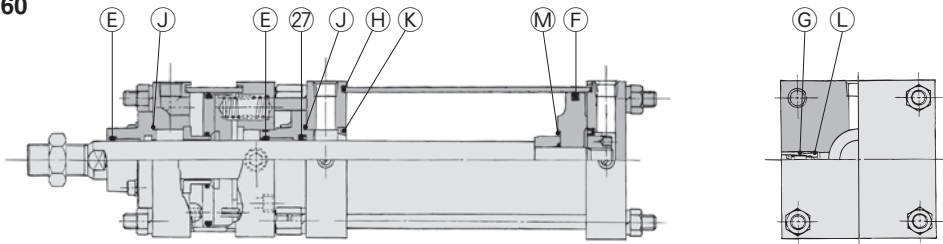

* The numbers are the same as the "Construction" of the Best Pneumatics No.3 Series CL1.

Seal Kit List

No.	Description	Material	Note
CL1ø40 to ø100			
25	Rod seal	NBR	
A	Cushion seal		
B	Piston seal		
C	Cushion valve seal		
D	Cylinder tube gasket		
CL1ø125 to ø160			
27	Rod seal	NBR	
E	Wiper ring		
F	Piston seal		
G	Valve seal		
H	Tube gasket		
J	Retaining plate gasket		
K	Cushion seal		
L	Guide gasket		
M	Piston gasket		

K, L and M are non-replaceable parts, so they are not included in the seal kit.

Replacement Parts: Seal Kit

Bore size (mm)	Kit no.	Contents
40	CL40-PS	
50	CL50-PS	
63	CL63-PS	
80	CL80-PS	
100	CL100-PS	
125	CL125-PS	
140	CL140-PS	
160	CL160-PS	

* Since the lock section for Series CL1 is normally replaced as a unit, kits are for the cylinder section only. These can be ordered using the order number for each bore size.

* Seal kit includes a grease pack (ø40, ø50: 10 g, ø63, ø80: 20 g, ø100: 30 g, ø125 to ø160: 40 g).

Order with the following part number when only the grease pack is needed.

Grease pack part no.: GR-S-010 (10 g), GR-S-020 (20 g)

* As for the center trunnion type, it is very difficult to adjust the position of the trunnion bracket and the center of the axis. Therefore repair at SMC is recommended.

Replacement Parts: Lock-up Unit

CL - 40 TN

Bore size (mm)

Port thread type

Nil	Rc
TN	NPT
TF	G

* Consult with SMC when replacing the lock-up unit with a bore size of ø125 to ø160.

Cylinder with Lock/Double Acting, Single Rod

Series CNG

ø20, ø25, ø32, ø40

Replacement
Procedure is
p.348

Construction

With rubber bumper: CNGBN

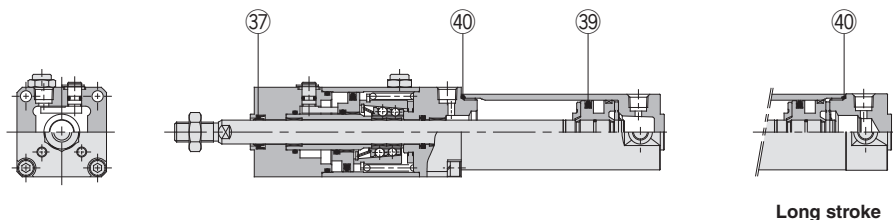

Long stroke

With air cushion: CNGBA

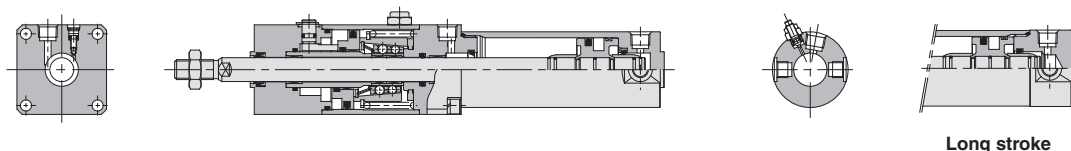

Long stroke

* The numbers are the same as the "Construction" of the Best Pneumatics No.3 Series CNG.

Seal Kit List

No.	Description	Material	Note
37	Rod seal A	NBR	
39	Piston seal		
40	Cylinder tube gasket		

Replacement Parts: Seal Kit

Bore size (mm)	Kit no.	Contents
20	CG1N20-PS	Set of left nos. 37, 39, 40
25	CG1N25-PS	
32	CG1N32-PS	
40	CG1N40-PS	

* Since the lock section for Series CNG is normally replaced as a unit, kits are for the cylinder section only. These can be ordered using the order number for each bore size.

* Seal kit includes a grease pack (10 g).
Order with the following part number when only the grease pack is needed.

Grease pack part no.: GR-S-010 (10 g)

Replacement Parts: Lock Unit

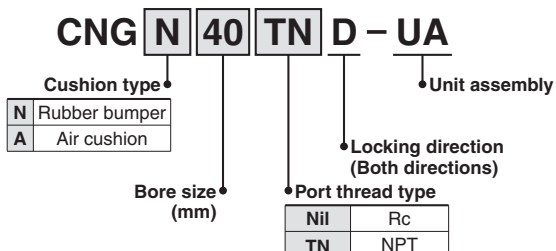

Actuators

Modular F.R.L.
Pressure Control Equipment

Air Preparation
Equipment

Industrial Filters

Replacement
Procedure

Actuators

Modular F.R.L.
Pressure Control Equipment

Industrial Filters

Series MNB

ø32, ø40, ø50
ø63, ø80, ø100



Construction

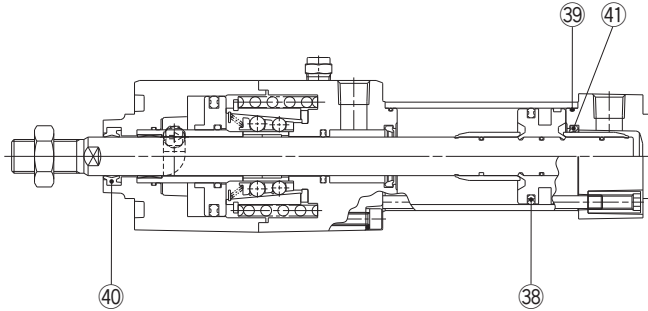

* The numbers are the same as the "Construction" of the Best Pneumatics No.3 Series MNB.

Seal Kit List

No.	Description	Material	Note
38	Piston seal	NBR	
39	Cylinder tube gasket		
40	Rod seal A		
41	Cushion seal		

Replacement Parts: Seal Kit

Bore size (mm)	Kit no.	Contents
32	MB32-PS	Set of left nos. 38, 39, 40, 41
40	MB40-PS	
50	MB50-PS	
63	MB63-PS	
80	MB80-PS	
100	MB100-PS	

* Since the lock section for Series MNB is normally replaced as a unit, kits are for the cylinder section only. These can be ordered using the order number for each bore size.

* Seal kit includes a grease pack (ø32 to ø50: 10 g, ø63 and ø80: 20 g, ø100: 30g).

Order with the following part number when only the grease pack is needed.

Grease pack part no.: GR-S-010 (10 g), GR-S-020 (20 g)

Replacement Parts: Lock Unit

MNB 40 TN D - UA

Bore size (mm) Unit assembly

Port thread type Locking direction (Both directions)

Nil	Rc
TN	NPT

G Port

C95N 40 D - UA

Bore size (mm) Unit assembly

Locking direction (Both directions)

Series MNBW

ø32, ø40, ø50
ø63, ø80, ø100

Replacement
Procedure is
p.351

Construction

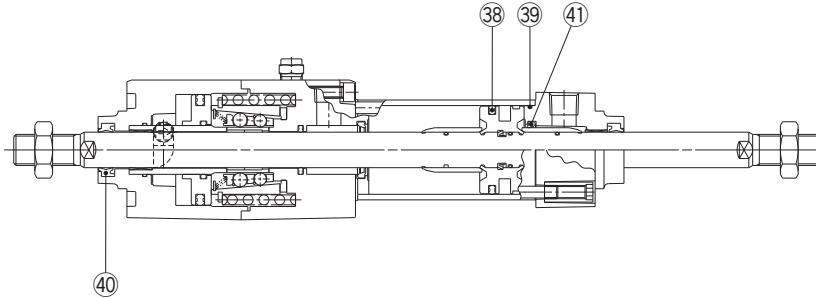

* The numbers are the same as the "Construction" of the Best Pneumatics No.3 Series MNBW.

Seal Kit List

No.	Description	Material	Note
38	Piston seal	NBR	
39	Cylinder tube gasket		
40	Rod seal A		
41	Cushion seal		

Replacement Parts: Seal Kit

Bore size (mm)	Kit no.	Contents
32	MBW32-PS	Set of left nos. 38, 39, 40, 41
40	MBW40-PS	
50	MBW50-PS	
63	MBW63-PS	
80	MBW80-PS	
100	MBW100-PS	

* As a general rule, the lock section of Series MNBW is replaced as a unit, and therefore, the replacement seal kits are for the cylinder section only. These can be ordered using the order number for each bore size.

* Seal kit includes a grease pack (ø32 to ø50: 10 g, ø63 and ø80: 20 g, ø100: 30g).

Order with the following part number when only the grease pack is needed.

Grease pack part no.: GR-S-010 (10 g), GR-S-020 (20 g)

Actuators

Modular F.R.L.
Pressure Control Equipment

Air Preparation
Equipment

Industrial Filters

Replacement
Procedure

Actuators

Modular F.R.L.
Pressure Control Equipment

Industrial Filters

Series CNA2

ø40, ø50, ø63
ø80, ø100

Replacement
Procedure is
P.351

Construction

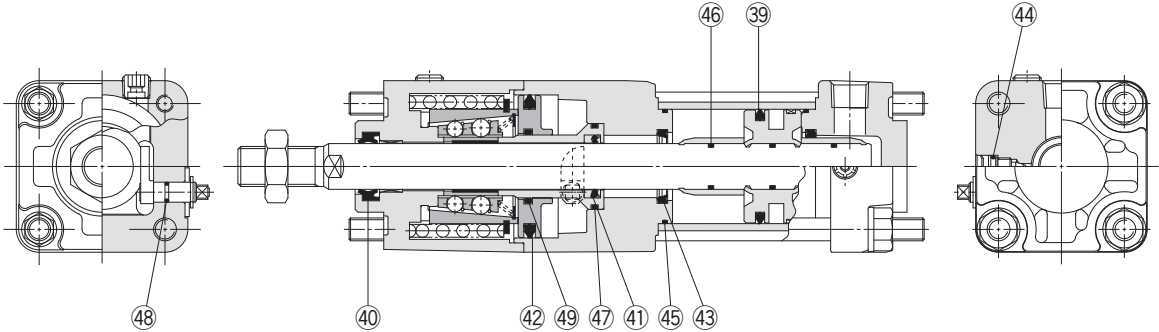

* The numbers are the same as the "Construction" of the CNA2 series catalog (CAT.ES20-206).

Seal Kit List

No.	Description	Material	Note
39	Piston seal	NBR	41, 42, 44 and 46 to 49 are non-replaceable parts, so they are not included in the seal kit.
40	Rod seal A	NBR	
41	Rod seal B	NBR	
42	Release piston seal	NBR	
43	Cushion seal	Urethane	
44	Cushion valve seal	NBR	
45	Tube gasket	NBR	
46	Piston gasket	NBR	
47	Piston guide gasket	NBR	
48	Unlocking cam gasket	NBR	
49	O-ring	NBR	

Replacement Parts: Seal Kit

Bore size (mm)	Kit no.	Contents
40	MB40-PS	Set of left nos. 39, 40, 43, 45
50	MB50-PS	
63	MB63-PS	
80	MB80-PS	
100	MB100-PS	

* Since the lock of the CNA2 series cannot be disassembled and is normally replaced as a unit, kits are for the cylinder section only. These can be ordered using the order number for each bore size.

* Seal kit includes a grease pack (ø40 and ø50: 10 g, ø63 and ø80: 20 g, ø100: 30 g).

Order with the following part number when only the grease pack is needed.

Grease pack part no.: GR-S-010 (10 g), GR-S-020 (20 g)

* As for the center trunnion type, it is very difficult to adjust the position of the trunnion bracket and the center of the axis. Therefore repair at SMC is recommended.

Replacement Parts: Lock Unit

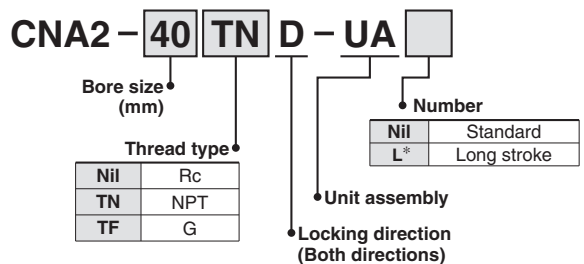

* The lock unit for a long-stroke cylinder is only applicable for flange type with bore size ø50 to ø100 and stroke 1001 or more. (Example: CNA2-100D-UAL)

Cylinder with Lock/Double Acting, Double Rod

Series CNA2W

ø40, ø50
ø63, ø80
ø100

Replacement
Procedure is
P.351

Construction

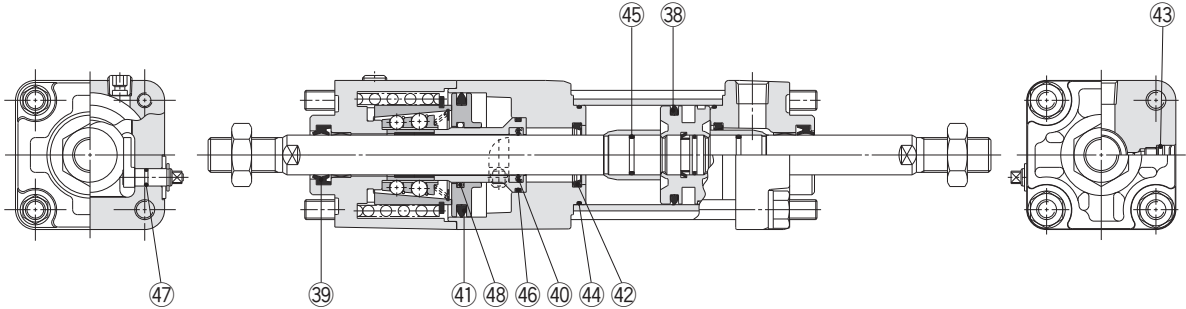

* The numbers are the same as the "Construction" of the CNA2 series catalog (CAT.ES20-206).

Seal Kit List

No.	Description	Material	Note
38	Piston seal	NBR	40, 41, 43 and 45 to 48 are non-replaceable parts, so they are not included in the seal kit.
39	Rod seal A	NBR	
40	Rod seal B	NBR	
41	Release piston seal	NBR	
42	Cushion seal	Urethane	
43	Cushion valve seal	NBR	
44	Tube gasket	NBR	
45	Piston gasket	NBR	
46	Piston guide gasket	NBR	
47	Unlocking cam gasket	NBR	
48	O-ring	NBR	

Replacement Parts: Seal Kit

Bore size (mm)	Kit no.	Contents
40	MBW40-PS	Set of left nos. 38, 39, 42, 44
50	MBW50-PS	
63	MBW63-PS	
80	MBW80-PS	
100	MBW100-PS	

* Since the lock of the CNA2 series cannot be disassembled and is normally replaced as a unit, kits are for the cylinder section only. These can be ordered using the order number for each bore size.

* Seal kit includes a grease pack (ø40 and ø50: 10 g, ø63 and ø80: 20 g, ø100: 30 g).

Order with the following part number when only the grease pack is needed.

Grease pack part no.: GR-S-010 (10 g), GR-S-020 (20 g)

* As for the center trunnion type, it is very difficult to adjust the position of the trunnion bracket and the center of the axis. Therefore repair at SMC is recommended.

Actuators

Modular F.R.L.
Pressure Control Equipment

Air Preparation
Equipment

Industrial Filters

Replacement
Procedure

Actuators

Modular F.R.L.
Pressure Control Equipment

Industrial Filters

Series CNS

ø125, ø140, ø160

Replacement
Procedure is
p.356

Construction

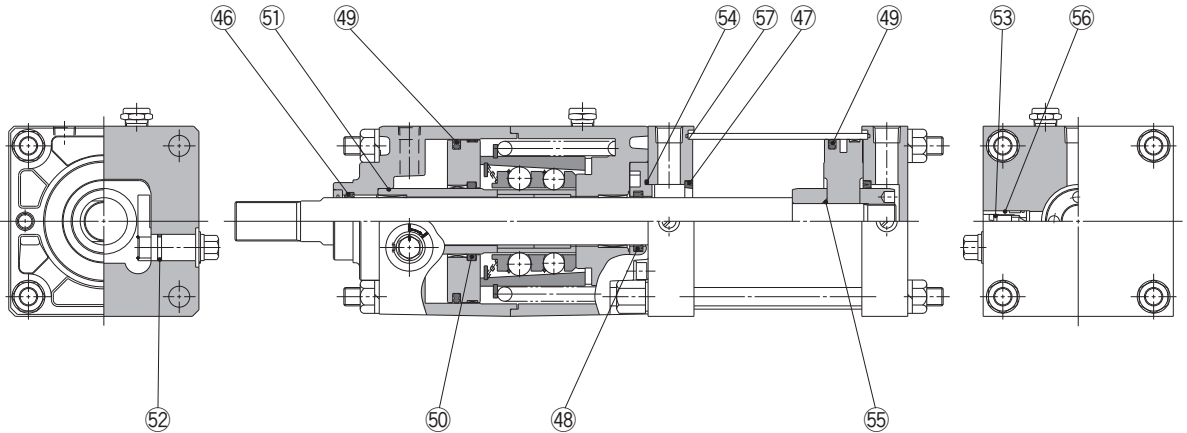

* The numbers are the same as the "Construction" of the Best Pneumatics No.3 Series CNS.

Seal Kit List

No.	Description	Material	Note
46	Wiper ring	NBR	47, 50 to 52, 55 and 56 are non-replaceable parts, so they are not included in the seal kit.
47	Cushion seal	NBR	
48	Rod seal	NBR	
49	Piston seal	NBR	
50	O-ring (for release piston)	NBR	
51	O-ring (for piston guide)	NBR	
52	O-ring (for unlocking cam)	NBR	
53	Valve seal	NBR	
54	Retaining plate gasket	NBR	
55	Piston gasket	NBR	
56	Guide gasket	NBR	
57	Tube gasket	NBR	

Replacement Parts: Seal Kit

Bore size (mm)	Kit no.	Contents
125	CS1N125A-PS	Set of left nos. (46, 48, 49, 53, 54, 57)
140	CS1N140A-PS	
160	CS1N160A-PS	

* Since the lock section for Series CNS is normally replaced as a unit, kits are for the cylinder section only. These can be ordered using the order number for each bore size.

* Seal kit includes 46, 48, 49, 53, 54, 57. Order the seal kit, based on each bore size.

* Seal kit includes a grease pack (40 g).

Order with the following part number when only the grease pack is needed.

Grease pack part no.: GR-S-010 (10 g), GR-S-020 (20 g)

* As for the center trunnion type, it is very difficult to adjust the position of the trunnion bracket and the center of the axis. Therefore repair at SMC is recommended.

Replacement Parts: Lock Unit

CNS 125 TN D - UA

Bore size (mm)

Unit assembly

Thread type

Locking direction (Both directions)

Nil	Rc
TN	NPT
TF	G

Series CLS

ø125, ø140, ø160
ø180, ø200, ø250

Replacement
Procedure is
P.358

Construction

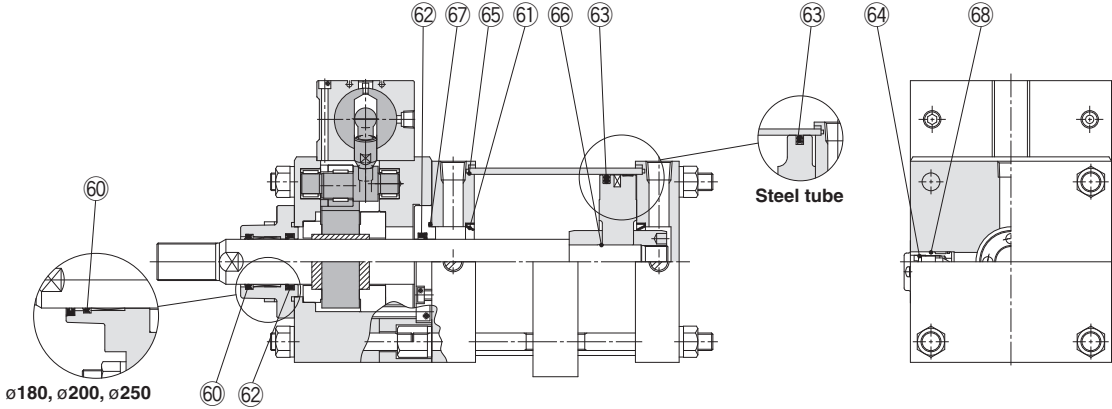

* The numbers are the same as the "Construction" of the Best Pneumatics No.3 Series CLS.

Seal Kit List

No.	Description	Material	Note
60	Wiper ring	NBR	61, 66 and 68 are non-replaceable parts, so they are not included in the seal kit.
61	Cushion seal		
62	Rod seal		
63	Piston seal		
64	Valve seal		
65	Tube gasket		
66	Piston gasket		
67	Retaining plate gasket		
68	Guide gasket		

Replacement Parts: Seal Kit

Bore size (mm)	Order No.	Contents
125	CS1N125A-PS	Set of left nos. 60, 62, 63, 64, 65, 67
140	CS1N140A-PS	
160	CS1N160A-PS	
180	CS1N180A-PS	
200	CS1N200A-PS	
250	CS1N250A-PS	

* Since the lock section for Series CLS is normally replaced as a unit, replacement seal kits are for the cylinder section only.
 ** Seal kits are sets consisting of items 60, 62, 63, 64, 65 and 67, which can be ordered using the order number for each cylinder bore size.
 * Seal kit includes a grease pack (ø125 to ø160: 40 g, ø180, ø200: 50 g, ø250: 60 g).
 Order with the following part number when only the grease pack is needed.
Grease pack part no.: GR-S-010 (10 g), GR-S-020 (20 g)

* As for the center trunnion type, it is very difficult to adjust the position of the trunnion bracket and the center of the axis.
 Therefore repair at SMC is recommended.

Replacement Parts: Lock Unit

CLS 125 TN - UA - D A93

Bore size (mm)

Port thread type

Nil	Rc
TN	NPT
TF	G

Lock unit auto switch

Nil Without auto switch

* Refer to the table below for applicable auto switch models

Lock unit built-in magnet

Nil	Without magnet (Without auto switch)
D	Built-in magnet

Cylinder Unit/Applicable Auto Switches

Type	Special function	Electrical entry	Indicator light	Wiring (output)	Load voltage		Auto switch model	Lead wire length (m)			Applicable load		
					DC	AC		0.5 (Nil)	3 (L)	5 (Z)			
Solid state switch	—	Grommet	Yes	3-wire (NPN)	24 V	5 V, 12 V	—	M9N	●	●	○	—	Relay, PLC
				3-wire (PNP)				M9P	●	●	○		
				2-wire				M9B	●	●	○		
Reed switch	—	Grommet	no	2-wire	24 V	5 V, 12 V	100 V or less	A90	●	●	—	IC circuit	Relay, PLC
			Yes					12 V	100 V	●	●		

Construction

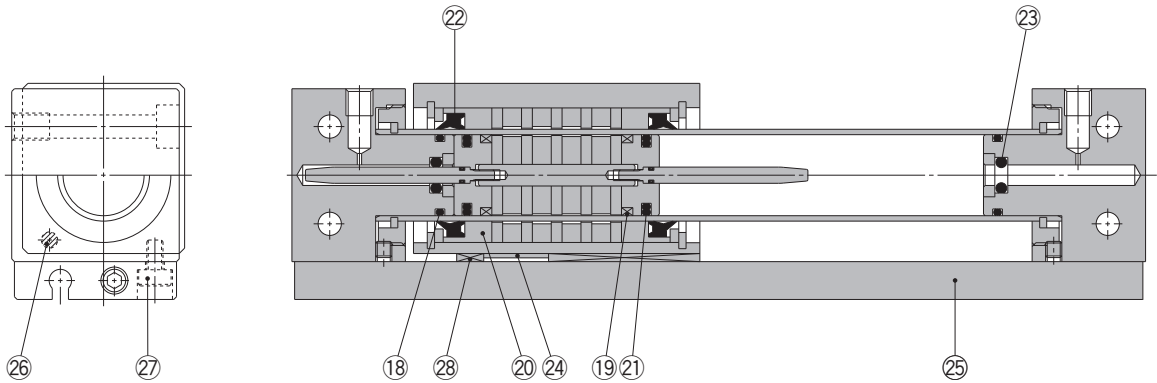

- * The numbers are the same as the "Construction" of the Best Pneumatics No.3 Series REAR.
- * The figure is for ø15. (The magnet for ø10 : 3 pcs.)

Seal Kit List

No.	Description	Material	Note
18	Cylinder tube gasket	NBR	
19	Wear ring A	Special resin	ø10: not available
20	Wear ring B	Special resin	
21	Piston seal	NBR	
22	Scraper	NBR	
23	Cushion seal	NBR	
24	Magnetic shielding plate	Rolled steel plate	Chromated
25	Switch rail	Aluminum alloy	Clear anodized
26	Magnet	—	
27	Hexagon socket head cap screw	Chromium steel	Nickel plated
28	Wear ring C	Special resin	

24 to 27 are non-replaceable parts, so they are not included in the seal kit.

Replacement Parts: Seal Kit

Bore size (mm)	Kit no.	Contents
10	REAR10-PS	Set of left nos. 18, 20, 21, 22, 23, 28
15	REAR15-PS	Set of left nos. 18, 19, 20, 21, 22, 23, 28 ^{Note)}

Note 1) It may be difficult to replace the cushion seal 23.

Note 2) For wear ring A of ø10, please consult with SMC.

* Seal kit includes a grease pack (ø10: 5 g and 10 g, ø15: 10 g).

Order with the following part number when only the grease pack is needed.

For ø10 grease pack part no.: GR-F-005 (5 g) for external sliding part

GR-S-010 (10 g) for tube interior

For ø15 grease pack part no.: GR-S-010 (10 g)

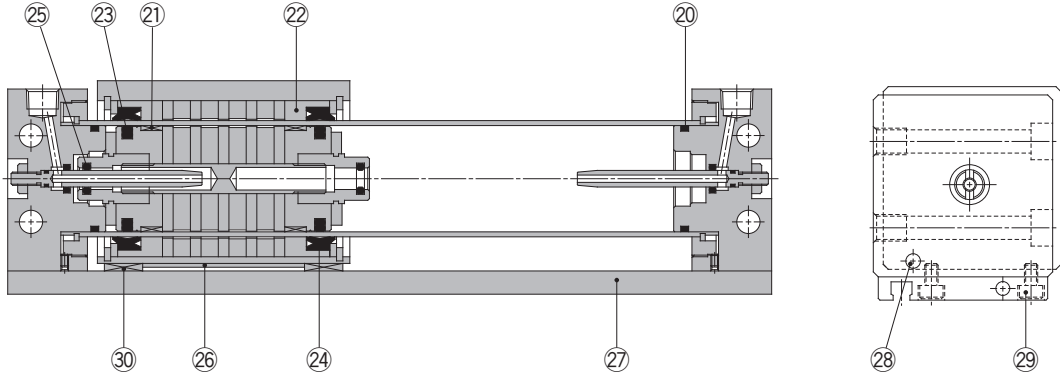
Construction

* The numbers are the same as the "Construction" of the Best Pneumatics No.3 Series REAR.

Seal Kit List

No.	Description	Material	Note
20	Cylinder tube gasket	NBR	
21	Wear ring A	Special resin	
22	Wear ring B	Special resin	
23	Piston seal	NBR	
24	Scraper	NBR	
25	Cushion seal	NBR	Chromated
26	Magnetic shielding plate	Rolled steel plate	Clear anodized
27	Switch rail	Aluminum alloy	
28	Magnet	—	Nickel plated
29	Hexagon socket head cap screw	Chromium steel	
30	Wear ring C	Special resin	

26 to 29 are non-replaceable parts, so they are not included in the seal kit.

Replacement Parts: Seal Kit

Bore size (mm)	Kit no.	Contents
20	REAR20-PS	Set of left nos. 20, 21, 22, 23, 24, 25, 30 Note)
25	REAR25-PS	
32	REAR32-PS	
40	REAR40-PS	

Note) Cushion seal 25 may be difficult to be replaced.

Note) Seal kit includes 20 to 25, 30. Order the seal kit, based on each bore size.

* Seal kit includes a grease pack (10 g).

Order with the following part number when only the grease pack is needed.

Grease pack part no.: GR-S-010 (10 g)

Series REAS ø10, ø15



Construction

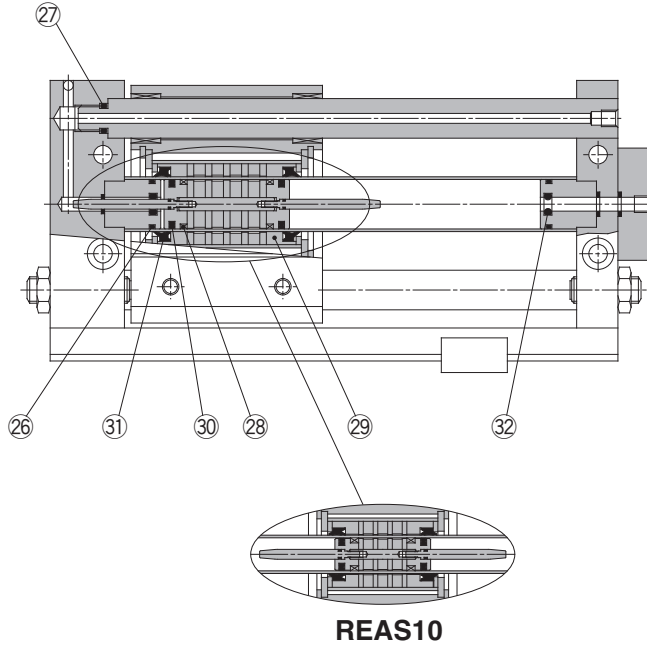

* The numbers are the same as the "Construction" of the Best Pneumatics No.3 Series REAS.

Seal Kit List

No.	Description	Material	Note
26	Cylinder tube gasket	NBR	
27	Guide shaft gasket	NBR	
28	Wear ring A	Special resin	ø10: Not available
29	Wear ring B	Special resin	
30	Piston seal	NBR	
31	Scraper	NBR	
32	Cushion seal	NBR	

* Seal kit includes 26 to 32. Order the seal kit, based on each bore size.

Replacement Parts: Seal Kit

Bore size (mm)	Kit no.	Contents
10	REAS10-PS	Set of left nos. 26, 27, 29, 30, 31, 32 <small>Note)</small>
15	REAS15-PS	Set of left nos. 26, 27, 28, 29, 30, 31, 32 <small>Note)</small>

Note) It may be difficult to replace the cushion seal 32.

Note) For wear ring A of ø10, please consult with SMC.

* Seal kit includes a grease pack (ø10: 5 g and 10 g, ø15: 10 g).

Order with the following part number when only the grease pack is needed.

**For ø10 grease pack part no.: GR-F-005 (5 g) for external sliding part
GR-S-010 (10 g) for tube interior**

For ø15 grease pack part no.: GR-S-010 (10 g)

Sine Rodless Cylinder/Slider Type: Slide Bearing

Series REAS

ø20, ø25, ø32, ø40

Replacement
Procedure is
P.361

Construction

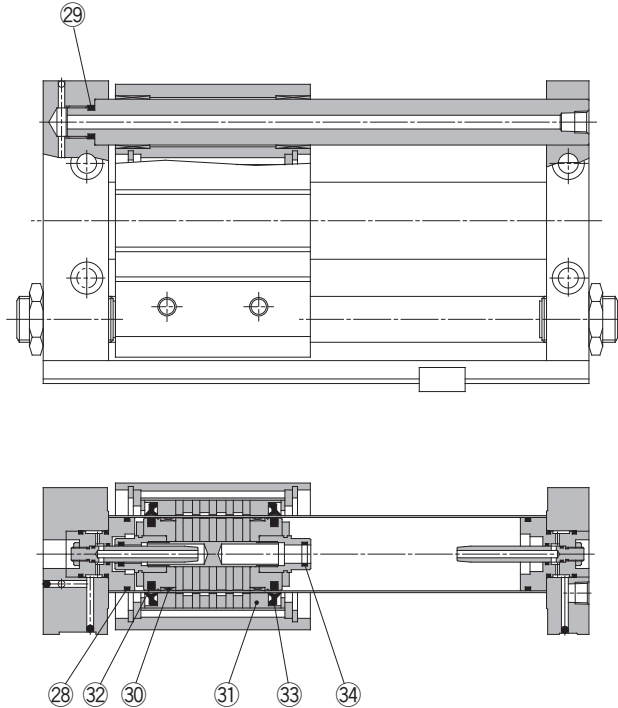

* The numbers are the same as the "Construction" of the Best Pneumatics No.3 Series REAS.

Seal Kit List

No.	Description	Material	Note
28	Cylinder tube gasket	NBR	
29	Guide shaft gasket	NBR	
30	Wear ring A	Special resin	
31	Wear ring B	Special resin	
32	Piston seal	NBR	
33	Scraper	NBR	
34	Cushion seal	NBR	

* Seal kit includes 28 to 34. Order the seal kit, based on each bore size.

Replacement Parts: Seal Kit

Bore size (mm)	Kit no.	Contents
20	REAS20-PS	Set of left nos. 28, 29, 30, 31, 32, 33, 34 ^{Note)}
25	REAS25-PS	
32	REAS32-PS	
40	REAS40-PS	

Note) Cushion seal 34 may be difficult to be replaced.

* Seal kit includes a grease pack (10 g).

Order with the following part number when only the grease pack is needed.

Grease pack part no.: GR-S-010 (10 g)

Actuators

Modular F.R.L.
Pressure Control Equipment

Air Preparation
Equipment

Industrial Filters

Replacement
Procedure

Actuators

Modular F.R.L.
Pressure Control Equipment

Industrial Filters

Series REAL

Ball Bushing Bearing: $\phi 10, \phi 15$

Construction

$\phi 10, \phi 15$

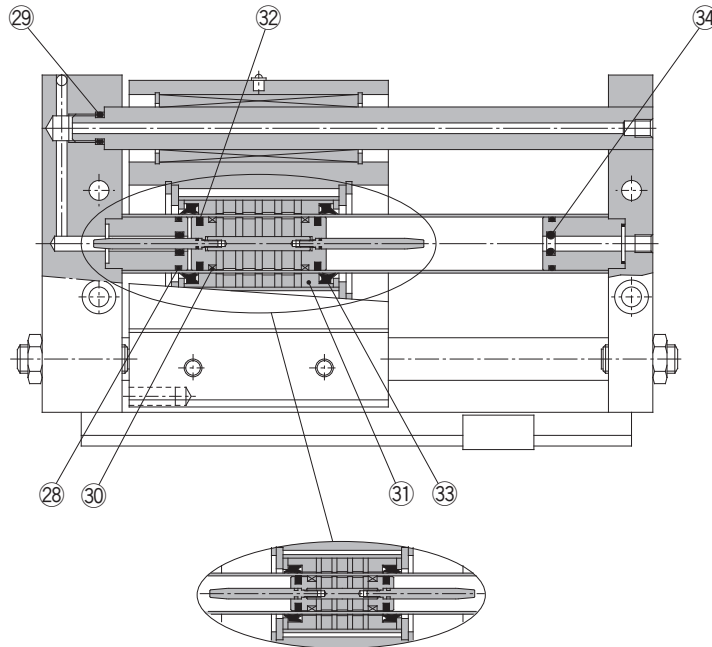

REAL10

* The numbers are the same as the "Construction" of the Best Pneumatics No.3 Series REAL.

Seal kit List

No.	Description	Material	Note
28	Cylinder tube gasket	NBR	
29	Guide shaft gasket	NBR	
30	Wear ring A	Special resin	$\phi 10$: Not available
31	Wear ring B	Special resin	
32	Piston seal	NBR	
33	Scraper	NBR	
34	Cushion seal	NBR	

Replacement Parts: Seal Kit

Bore size (mm)	Kit no.	Contents
10	REAL10-PS	Set of left nos. 28, 29, 31, 32, 33, 34
15	REAS15-PS	Set of left nos. 28, 29, 30, 31, 32, 33, 34

* Seal kit includes 28 to 34. Order the seal kit, based on each bore size.
Note) It may be difficult to replace the cushion seal 34.

Note) For wear ring A of $\phi 10$, please consult with SMC.

* Seal kit includes a grease pack ($\phi 10$: 5 g and 10 g, $\phi 15$: 10 g).

Order with the following part number when only the grease pack is needed.

For $\phi 10$ grease pack part no.: GR-F-005 (5 g) for external sliding part
GR-S-010 (10 g) for tube interior

For $\phi 15$ grease pack part no.: GR-S-010 (10 g)

Series REAL

Ball Bushing Bearing: $\varnothing 20$, $\varnothing 25$
 $\varnothing 32$, $\varnothing 40$

Construction

$\varnothing 20$ to $\varnothing 40$

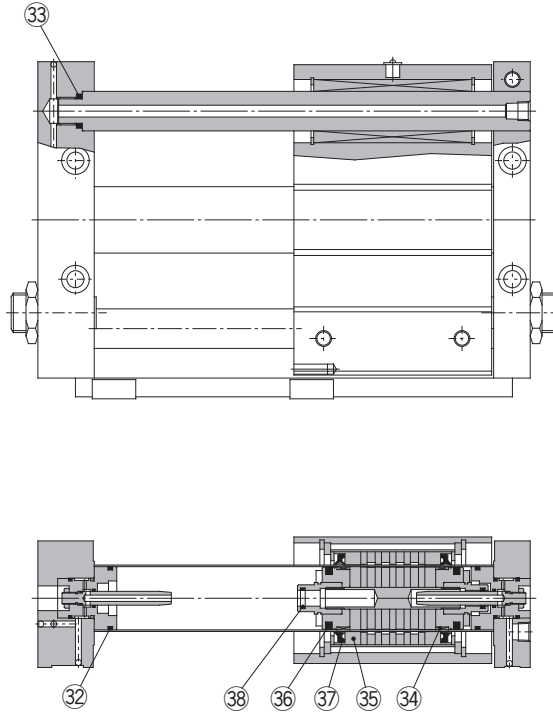

* The numbers are the same as the "Construction" of the Best Pneumatics No.3 Series REAL.

Seal Kit List

No.	Description	Material	Note
32	Cylinder tube gasket	NBR	
33	Guide shaft gasket	NBR	
34	Wear ring A	Special resin	
35	Wear ring B	Special resin	
36	Piston seal	NBR	
37	Scraper	NBR	
38	Cushion seal	NBR	

Replacement Parts: Seal Kit

Bore size (mm)	Kit no.	Contents
20	REAS20-PS	Set of left nos. 32, 33, 34, 35, 36, 37, 38
25	REAS25-PS	
32	REAS32-PS	
40	REAS40-PS	

* Seal kit includes 32 to 38. Order the seal kit, based on each bore size. Note) It may be difficult to replace the cushion seal 38.

* Seal kit includes a grease pack (10 g).

Order with the following part number when only the grease pack is needed.

Grease pack part no.: GR-S-010 (10 g)

Actuators

Modular F.R.L.
Pressure Control Equipment

Air Preparation
Equipment

Industrial Filters

Replacement
Procedure

Actuators

Modular F.R.L.
Pressure Control Equipment

Industrial Filters

Series REAH

Single axis type: $\phi 10$, $\phi 15$

Construction

Single axis type: $\phi 10$, $\phi 15$

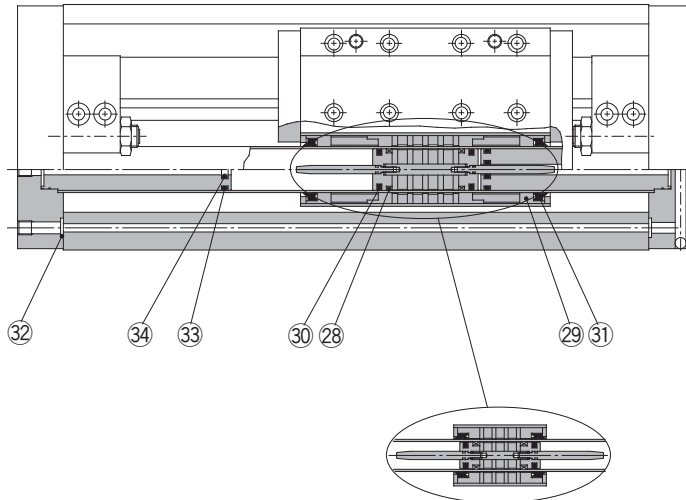

REAH10

* The numbers are the same as the "Construction" of the Best Pneumatics No.3 Series REAH.

Seal Kit List

No.	Description	Material	Note
28	Wear ring A	Special resin	$\phi 10$: Not available
29	Wear ring B	Special resin	
30	Piston seal	NBR	
31	Scraper	NBR	
32	O-ring	NBR	
33	O-ring	NBR	
34	Cushion seal	NBR	

Replacement Parts: Seal Kit

Bore size (mm)	Kit no.	Contents
10	REAH10-PS	Set of left nos. 29, 30, 31, 32, 33, 34
15	REAH15-PS	Set of left nos. 28, 29, 30, 31, 32, 33, 34

Note) Seal kit includes 28 to 34. Order the seal kit, based on each bore size.

Note) It may be difficult to replace the cushion seal 34.

Note) For wear ring A of $\phi 10$, please consult with SMC.

* Seal kit includes a grease pack ($\phi 10$: 5 g and 10 g, $\phi 15$: 10 g).

Order with the following part number when only the grease pack is needed.

**For $\phi 10$ grease pack part no.: GR-F-005 (5 g) for external sliding part
GR-S-010 (10 g) for tube interior**

For $\phi 15$ grease pack part no.: GR-S-010 (10 g)

Series REAH

Single axis type: $\varnothing 20$, $\varnothing 25$

Construction

Single axis type: $\varnothing 20$, $\varnothing 25$

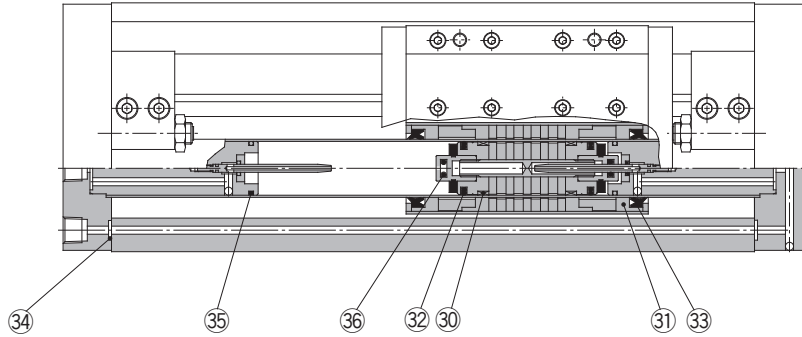

* The numbers are the same as the "Construction" of the Best Pneumatics No.3 Series REAH.

Seal Kit List

No.	Description	Material	Note
30	Wear ring A	Special resin	
31	Wear ring B	Special resin	
32	Piston seal	NBR	
33	Scraper	NBR	
34	O-ring	NBR	
35	O-ring	NBR	
36	Cushion seal	NBR	

Replacement Parts: Seal Kit

Bore size (mm)	Kit no.	Contents
20	REAH20-PS	Set of left nos.
25	REAH25-PS	30, 31, 32, 33, 34, 35, 36

Note) Seal kit includes 30 to 36. Order the seal kit, based on each bore size.

Note) It may be difficult to replace the cushion seal 36.

* Seal kit includes a grease pack (10 g).

Order with the following part number when only the grease pack is needed.

Grease pack part no.: GR-S-010 (10 g)

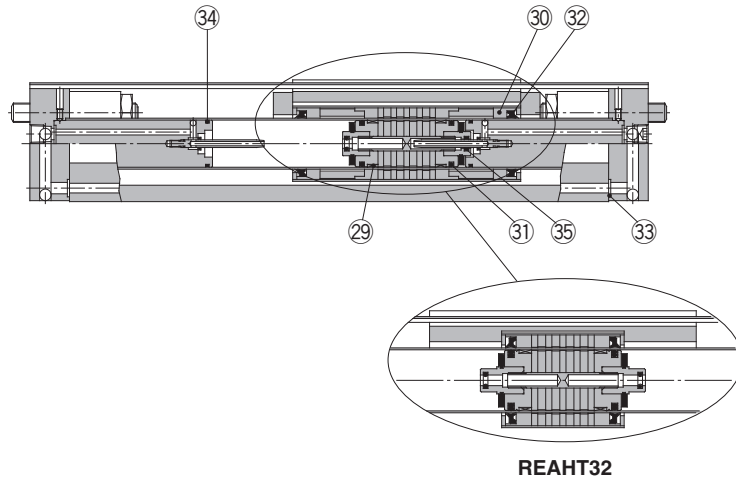
Series REAHDouble axis type: $\phi 25$, $\phi 32$ **Construction**Double axis type: $\phi 25$, $\phi 32$ 

* The numbers are the same as the "Construction" of the Best Pneumatics No.3 Series REAH.

Seal Kit List

No.	Description	Material	Note
29	Wear ring A	Special resin	
30	Wear ring B	Special resin	
31	Piston seal	NBR	
32	Scraper	NBR	
33	O-ring	NBR	
34	O-ring	NBR	
35	Cushion seal	NBR	

Replacement Parts: Seal Kit

Bore size (mm)	Kit no.	Contents
25	REAHT25-PS	Set of left nos. 29, 30, 31, 32, 33, 34, 35
32	REAHT32-PS	

Note) Seal kit includes 29 to 35. Order the seal kit, based on each bore size.

Note) It may be difficult to replace the cushion seal 35.

* Seal kit includes a grease pack (10 g).

Order with the following part number when only the grease pack is needed.

Grease pack part no.: GR-S-010 (10 g)

Series REBR ø15, ø25, ø32



Construction

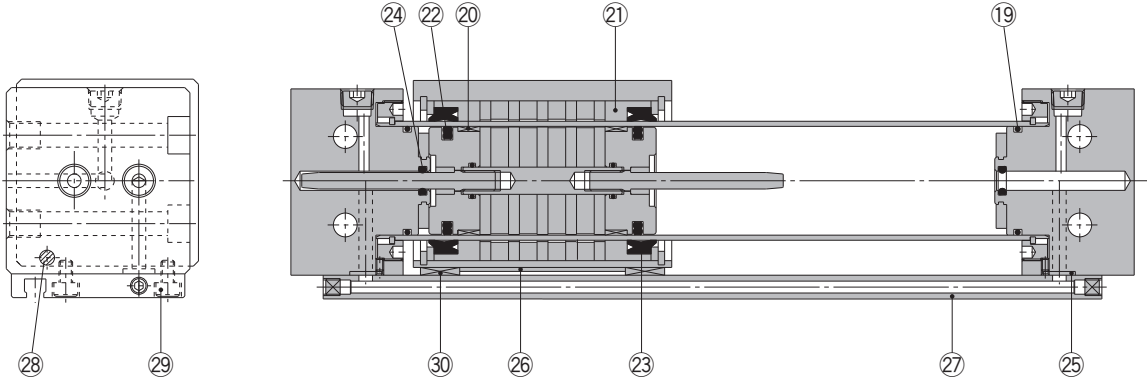

* The numbers are the same as the "Construction" of the Best Pneumatics No.3 Series REBR.

Seal Kit List

No.	Description	Material	Note
19	Cylinder tube gasket	NBR	26 to 29 are non-replaceable parts, so they are not included in the seal kit.
20	Wear ring A	Special resin	
21	Wear ring B	Special resin	
22	Piston seal	NBR	
23	Scraper	NBR	
24	Cushion seal	NBR	
25	Switch rail gasket	NBR	
26	Magnetic shielding plate	Rolled steel plate/Chromated	
27	Switch rail	Aluminum alloy/Clear anodized	
28	Magnet	—	
29	Hexagon socket head cap screw	Chromium steel/Nickel plated	
30	Wear ring C	Special resin	

Replacement Parts: Seal Kit

Bore size (mm)	Kit no.	Contents
15	REBR15-PS	Set of left nos. 19, 20, 21, 22, 23, 24, 25, 30
25	REBR25-PS	
32	REBR32-PS	

Note) Cushion seal 24 may be difficult to be replaced.

* Seal kit includes a grease pack (10 g).

Order with the following part number when only the grease pack is needed.

Grease pack part no.: GR-S-010 (10 g)

Actuators

Modular F.R.L.
Pressure Control Equipment

Air Preparation
Equipment

Industrial Filters

Replacement
Procedure

Actuators

Modular F.R.L.
Pressure Control Equipment

Industrial Filters

Series REBH

Single axis type: $\varnothing 15$, $\varnothing 25$

Construction

Single axis type: $\varnothing 15$, $\varnothing 25$

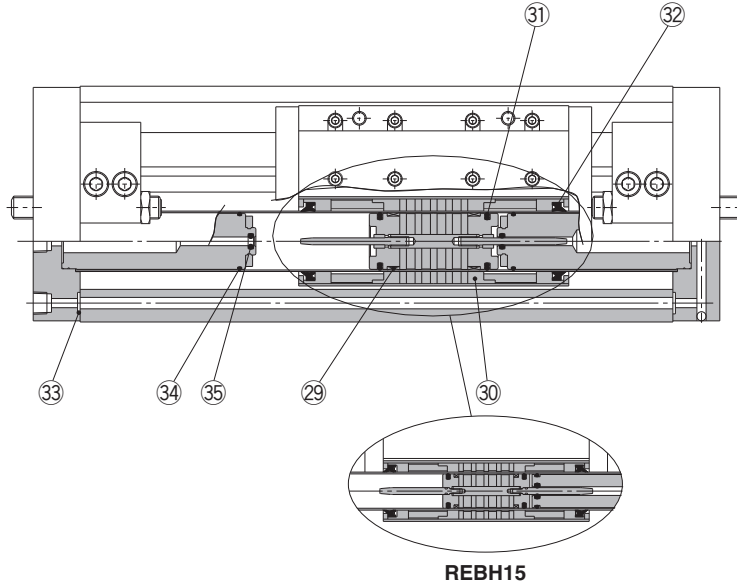

* The numbers are the same as the "Construction" of the Best Pneumatics No.3 Series REBH.

Seal Kit List

No.	Description	Material	Note
29	Wear ring A	Special resin	
30	Wear ring B	Special resin	
31	Piston seal	NBR	
32	Scraper	NBR	
33	O-ring	NBR	
34	O-ring	NBR	
35	Cushion seal	NBR	

Replacement Parts: Seal Kit

Bore size (mm)	Kit no.	Contents
15	REBH15-PS	Set of left nos. 29, 30, 31, 32, 33, 34, 35
25	REBH25-PS	

Note) Cushion seal 35 may be difficult to be replaced.

* Seal kit includes a grease pack (10 g).

Order with the following part number when only the grease pack is needed.

Grease pack part no.: GR-S-010 (10 g)

Series REBH

Double axis type: $\phi 25$, $\phi 32$

Construction

Double axis type: $\phi 25$, $\phi 32$

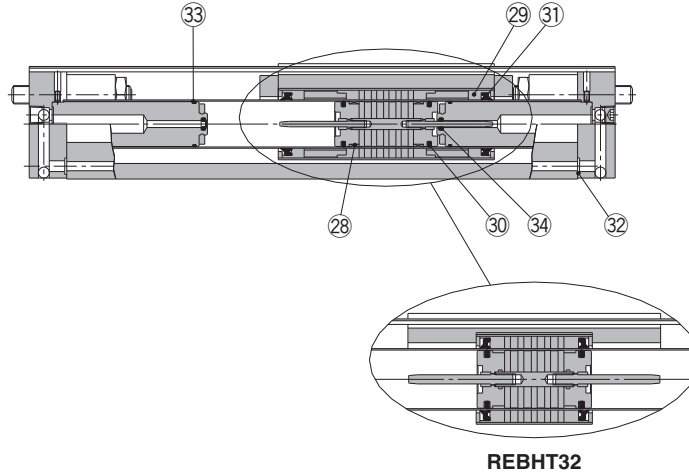

* The numbers are the same as the "Construction" of the Best Pneumatics No.3 Series REBH.

Seal Kit List

No.	Description	Material	Note
28	Wear ring A	Special resin	
29	Wear ring B	Special resin	
30	Piston seal	NBR	
31	Scraper	NBR	
32	O-ring	NBR	
33	O-ring	NBR	
34	Cushion seal	NBR	

Replacement Parts: Seal Kit

Bore size (mm)	Kit no.	Contents
25	REBH25-PS	Set of left nos.
32	REBH32-PS	28, 29, 30, 31, 32, 33, 34

Note) Cushion seal 34 may be difficult to be replaced.

* Seal kit includes a grease pack (10 g).

Order with the following part number when only the grease pack is needed.

Grease pack part no.: GR-S-010 (10 g)

Actuators

Modular F.R.L.
Pressure Control Equipment

Air Preparation
Equipment

Industrial Filters

Replacement
Procedure

Actuators

Modular F.R.L.
Pressure Control Equipment

Industrial Filters

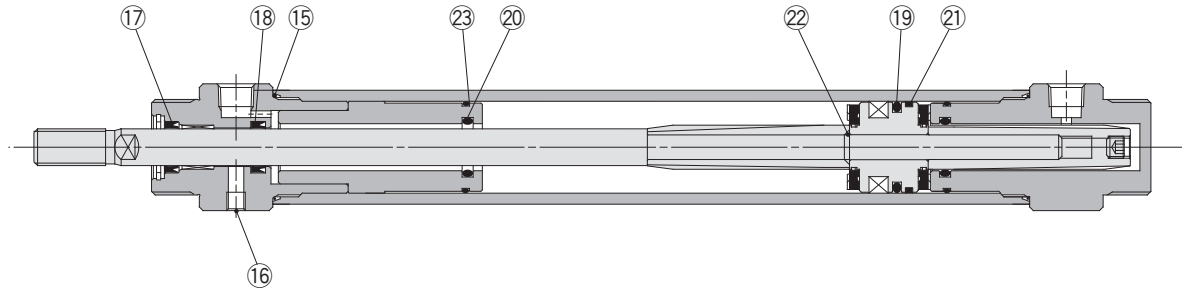
Construction

* The numbers are the same as the "Construction" of the Best Pneumatics No.3 Series REC.

Seal Kit List

No.	Description	Material	Qty.	Note
15	Cylinder tube gasket	NBR	2	
16	Hexagon socket head set screw	Carbon steel	1	Nickel plated
17	Rod seal A	NBR	1	
18	Rod seal B	NBR	1	
19	Piston seal	NBR	1	
20	Cushion seal	NBR	2	
21	Wear ring	Resin	1	
22	Piston gasket	NBR	1	
23	Holder gasket	NBR	2	

16, 18 and 22 are non-replaceable parts, so they are not included in the seal kit.

Replacement Parts: Seal Kit

Bore size (mm)	Kit no.	Contents
20	REC20-PS	Set of left nos. 15, 17, 19, 20, 21, 23
25	REC25-PS	
32	REC32-PS	
40	REC40-PS	

* Seal kit includes a grease pack (10 g).
Order with the following part number when only the grease pack is needed.

Grease pack part no.: GR-S-010 (10 g)

⚠ Caution

When disassembling cylinders with bore sizes of ø20 to ø40, grip the double flat part of either the tube cover or the rod cover with a vise and loosen the other side with a wrench or an adjustable angle wrench, and then remove the cover. When re-tightening, tighten approximately 2 degrees more than the original position.

Series RHC

ø20, ø25, ø32, ø40
ø50, ø63, ø80, ø100

Replacement
Procedure is
P.364

Construction

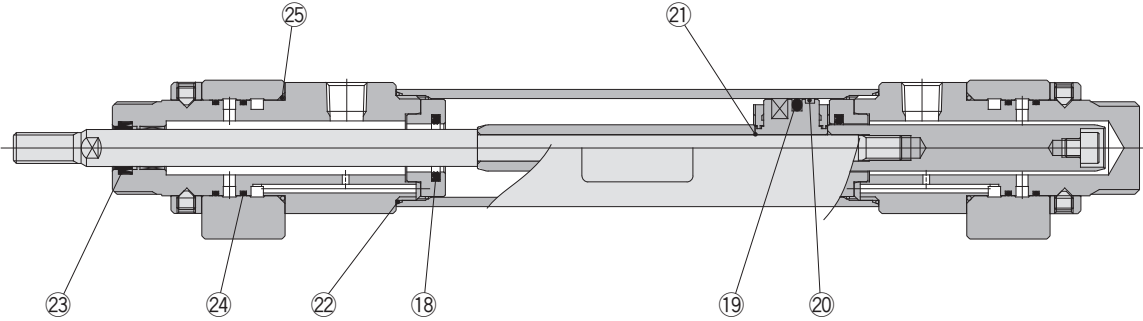

* The numbers are the same as the "Construction" of the Best Pneumatics No.3 Series RHC.

Seal Kit List

No.	Description	Material	Note
18	Cushion seal	Special resin	21 is a non-replaceable part, so it is not included in the seal kit.
19	Piston seal	NBR	
20	Wear ring	Resin	
21	Piston gasket	NBR	
22	Cylinder tube gasket	NBR	
23	Rod seal	NBR	
24	O-ring	NBR	
25	O-ring	NBR	

Replacement Parts: Seal Kit

Bore size (mm)	Kit no.	Contents
20	RHC20-PS	Set of left nos. 18, 19, 20, 22, 23, 24, 25
25	RHC25-PS	
32	RHC32-PS	
40	RHC40-PS	

* Seal kit includes a grease pack (10 g).
Order with the following part number when only the grease pack is needed.

Grease pack part no.: GR-S-010 (10 g)

⚠ Caution

When disassembling cylinders with bore sizes of ø20 through ø40, grip the double flat part of either the rod cover or the head cover with a vise and loosen the other side with a wrench or an adjustable angle wrench, and then remove the cover. When retightening, tighten approximately 2 degrees more than the original position.

Actuators

Modular F.R.L.
Pressure Control Equipment

Air Preparation
Equipment

Industrial Filters

Replacement
Procedure

Actuators

Modular F.R.L.
Pressure Control Equipment

Industrial Filters

3 Position Cylinder

Series RZQ

ø32, ø40, ø50, ø63



Construction

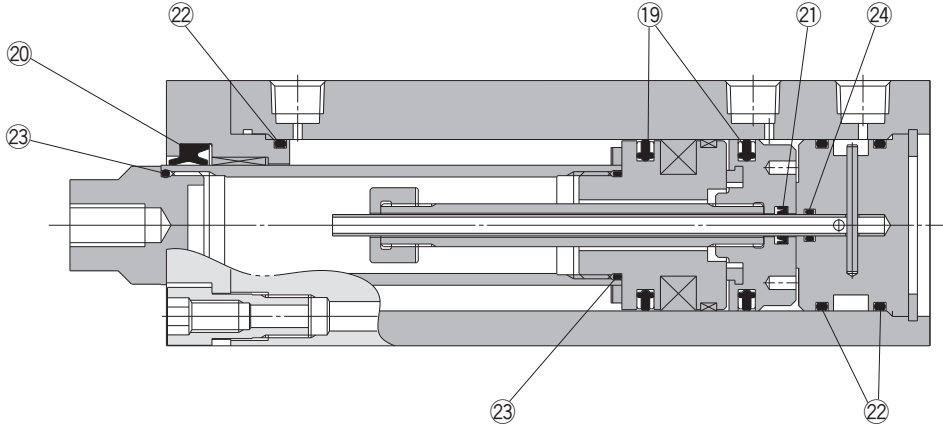

* The numbers are the same as the "Construction" of the Best Pneumatics No.3 Series RZQ.

Seal Kit List

No.	Description	Material	Note
19	Piston seal	NBR	23 is a non-replaceable part, so it is not included in the seal kit.
20	Rod seal A		
21	Rod seal B		
22	Gasket A		
23	Gasket B		
24	Gasket C		

Replacement Parts: Seal Kit

Bore size (mm)	Kit no.	Contents
32	RZQ32-PS	Set of left nos. 19, 20, 21, 22, 24
40	RZQ40-PS	
50	RZQ50-PS	
63	RZQ63-PS	

* Seal kits are sets consisting of items 19, 20, 21, 22 and 24 and can be ordered using the seal kit number for each cylinder bore size.

* Since the seal kit does not include a grease pack, order it separately.
Grease pack part no. GR-L-010 (10 g)

Series MK

ø12, ø16, ø20, ø25
ø32, ø40, ø50, ø63



Construction

New MK12, 16

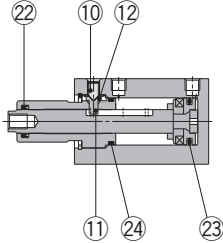

New MK20 to 32

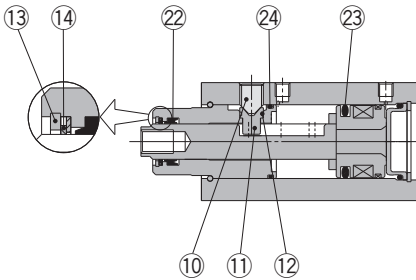

New MK40 to 63

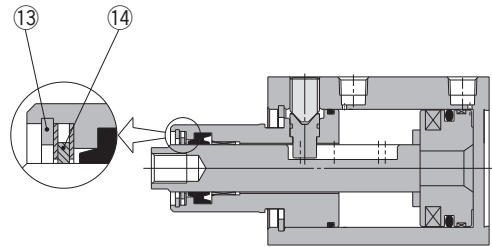

* The numbers are the same as the "Construction" of the MK series catalog (CAT.ES20-214).

Seal Kit List

No.	Description	Material	Note
⑩	Hexagon socket head set screw	Chromium molybdenum steel	Sharp end section: 90°
⑪	Guide pin	Stainless steel	Nitriding
⑫	O-ring	NBR	
⑬	Round R-type retaining ring	Carbon tool steel	Except ø12, ø16
⑭	Coil scraper	Phosphor bronze	Except ø12, ø16
⑳	Rod seal	NBR	
㉑	Piston seal	NBR	
㉒	Gasket	NBR	

13 is a non-replaceable part, so it is not included in the seal kit.

Replacement Parts: Seal Kit

Bore size (mm)	Kit no.	Contents
12	CQSB12-PS	Set of left nos. ㉒, ㉑, ㉒
16	CQSB16-PS	
20	MK20Z-PS	Set of left nos. ⑭, ㉒, ㉑, ㉒
25	MK25Z-PS	
32	MK32Z-PS	
40	MK2T40-PS	
50	MK2T50-PS	
63	MK63Z-PS	

* Seal kit includes numbers in the table. Order the seal kit, based on each bore size.

* Since the seal kit does not include a grease pack, order it separately.

Grease pack part no.: GR-S-010 (10 g)

Replacement Parts: Guide Pin Kit

Bore size (mm)	Kit no.	Contents
12	MK12Z-GS	Set of left nos. ⑩, ⑪, ⑫
16	MK16Z-GS	
20	MK20Z-GS	
25	MK25Z-GS	
32	MK32Z-GS	
40	MK40Z-GS	
50	MK50Z-GS	
63	MK63Z-GS	

* Guide pin kit includes numbers in the table. Order the guide pin kit, based on each bore size.

* For the replacement procedure of the replacement parts/seal and guide pin kits, refer to the Operation Manual.

Actuators

Modular F.R.L.
Pressure Control Equipment

Air Preparation
Equipment

Industrial Filters

Replacement
Procedure

Actuators

Modular F.R.L.
Pressure Control Equipment

Industrial Filters

Rotary Clamp Cylinder/Double Guide Type

Series MK2T

ø20, ø25, ø32
ø40, ø50, ø63



Construction

MK2T□20 to 63

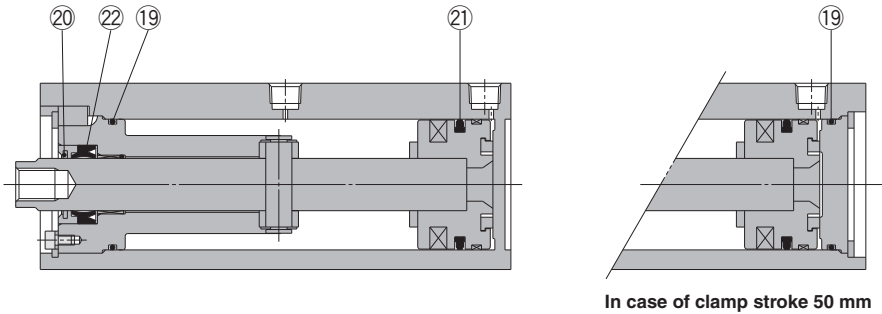

* The numbers are the same as the "Construction" of the Best Pneumatics No.3 Series MK2T.

Seal Kit List

No.	Description	Material	Note
19	Gasket	NBR	
20	Coil scraper	Bronze	
21	Piston seal	NBR	
22	Rod seal	NBR	

Replacement Parts: Seal Kit

Bore size (mm)	Kit no.	Content
20	MK2T20-PS	Set of left nos. 19, 20, 21, 22
25	MK2T25-PS	
32	MK2T32-PS	
40	MK2T40-PS	
50	MK2T50-PS	
63	MK2T63-PS	

* Seal kit includes 19, 20, 21, 22. Order the seal kit, based on each bore size.



Series CKQGD/CKQPD

Replacement Procedure is p.374

Construction

CKQGDA50

* The below figures indicate the CKQGDA50-□RAL.

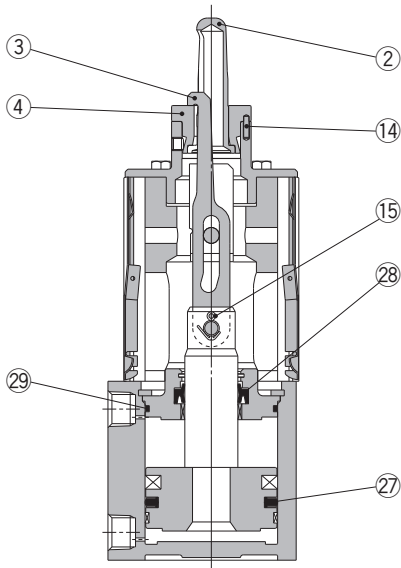

* There's no seal kit for CLKQGDA50.

* The numbers are the same as the "Construction" of the Best Pneumatics No.3 Series CKQ□D/CLKQ□D.

CKQPDA50

* The below figures indicate the CKQPDA50-□RAL.

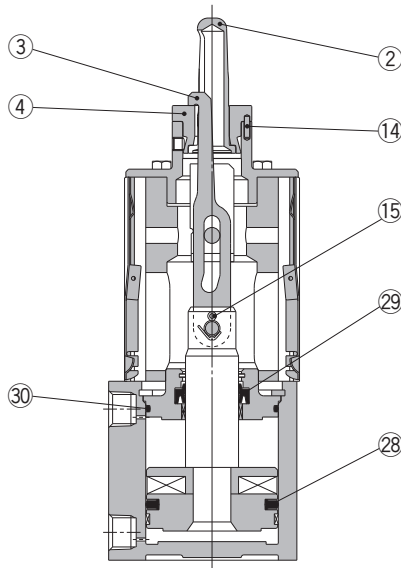

* There's no seal kit for CLKQPDA50.

* The numbers are the same as the "Construction" of the Best Pneumatics No.3 Series CKQ□D/CLKQ□D.

Seal Kit List

No.	Description	Material	Note
27	Piston seal	NBR	
28	Rod seal		
29	Tube gasket		

Replacement Parts: Seal Kit

Kit no.	Content
CQ2B50-PS	Set of nos. above. 27, 28, 29

* Consult SMC for maintenance service. Seal kit for maintenance of the CLKQ□ series with lock is not available.

Replacement Parts: Grease Pack

Grease pack part no.	Content
GR-S-010	Grease 10 g (Lithium)

* Consult SMC when replacing the actuating cylinders.

Seal Kit List

No.	Description	Material	Note
28	Piston seal	NBR	
29	Rod seal		
30	Tube gasket		

Replacement Parts: Seal Kit

Kit no.	Content
CQ2B50-PS	Set of nos. above. 28, 29, 30

* Consult SMC for maintenance service. Seal kit for maintenance of the CLKQ□ series with lock is not available.

Replacement Parts: Grease Pack

Grease pack part no.	Content
GR-S-010	Grease 10 g (Lithium)

* Consult SMC when replacing the actuating cylinders.

Guide Pins Assembly List

No.	Description	Material	Note
2, 4	Guide pins assembly	Stainless steel	
14	Parallel pin	Tool steel	

* Refer to page 183 for the guide pins assembly.

Clamp Arm Assembly List

No.	Description	Material	Note
3	Clamp arm	Structural steel	
15	Cotter pin	Stainless steel	

Actuators

Modular F.R.L.
Pressure Control Equipment

Air Preparation
Equipment

Industrial Filters

Replacement
Procedure

Actuators

Modular F.R.L.
Pressure Control Equipment

Industrial Filters

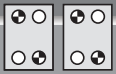

Series CKQGU/CKQPU

Replacement Procedure is p.374

Construction

CKQGUA50

* The below figures indicate the CKQGUA50-□RAL.

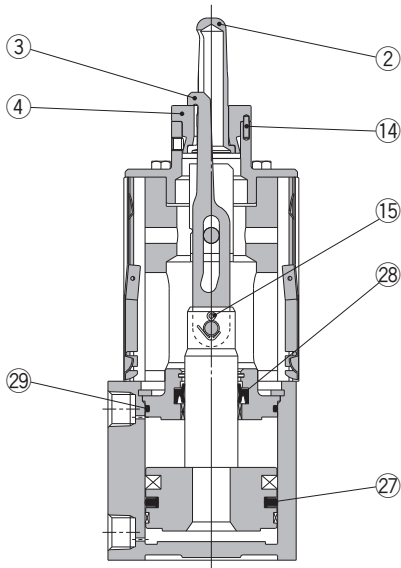

* There's no seal kit for CLKQGUA50.

* The numbers are the same as the "Construction" of the Best Pneumatics No.3 Series CKQ□U/CLKQ□U.

CKQPUA50

* The below figures indicate the CKQPUA50-□RAL.

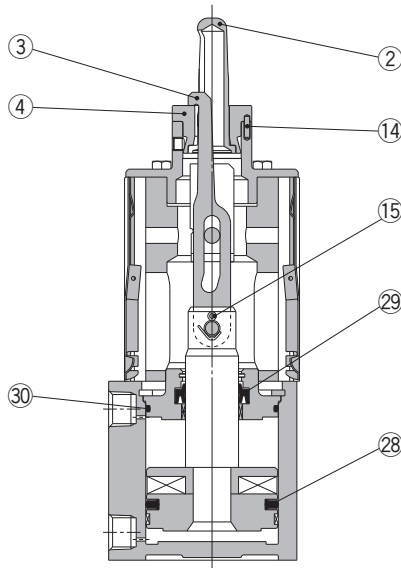

* There's no seal kit for CLKQPUA50.

* The numbers are the same as the "Construction" of the Best Pneumatics No.3 Series CKQ□U/CLKQ□U.

Seal Kit List

No.	Description	Material	Note
②⑦	Piston seal	NBR	
②⑧	Rod seal		
②⑨	Tube gasket		

Replacement Parts: Seal Kit

Kit no.	Content
CQ2B50-PS	Set of nos. above. ②⑦, ②⑧, ②⑨

* Consult SMC for maintenance service. Seal kit for maintenance of the CLKQ□ series with lock is not available.

Replacement Parts: Grease Pack

Grease pack part no.	Content
GR-S-010	Grease 10 g (Lithium)

* Consult SMC when replacing the actuating cylinders.

Seal Kit List

No.	Description	Material	Note
②⑧	Piston seal	NBR	
②⑨	Rod seal		
③⑩	Tube gasket		

Replacement Parts: Seal Kit

Kit no.	Content
CQ2B50-PS	Set of nos. above. ②⑧, ②⑨, ③⑩

* Consult SMC for maintenance service. Seal kit for maintenance of the CLKQ□ series with lock is not available.

Replacement Parts: Grease Pack

Grease pack part no.	Content
GR-S-010	Grease 10 g (Lithium)

* Consult SMC when replacing the actuating cylinders.

Guide Pins Assembly List

No.	Description	Material	Note
②④	Guide pins assembly	Stainless steel	
①④	Parallel pin	Tool steel	

* Refer to page 183 for the guide pins assembly.

Clamp Arm Assembly List

No.	Description	Material	Note
③	Clamp arm	Structural steel	
①⑤	Cotter pin	Stainless steel	

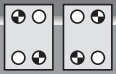

Series CKQGK/CKQPK

Replacement Procedure is P.374

Construction

CKQGK50

* The below figures indicate the CKQGK50-□RAL.

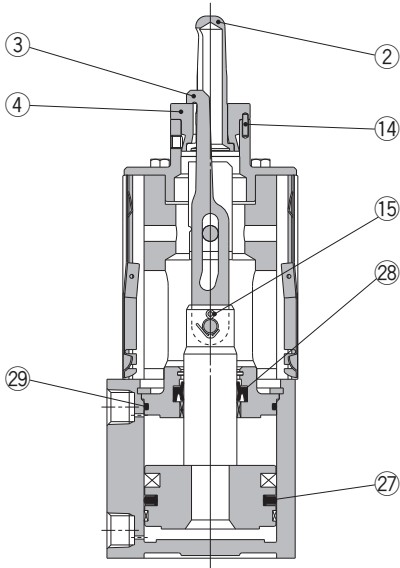

* There's no seal kit for CKQGK50.

* The numbers are the same as the "Construction" of the Best Pneumatics No.3 Series CKQ□K/CLKQ□K.

CKQPK50

* The below figures indicate the CKQPK50-□RAL.

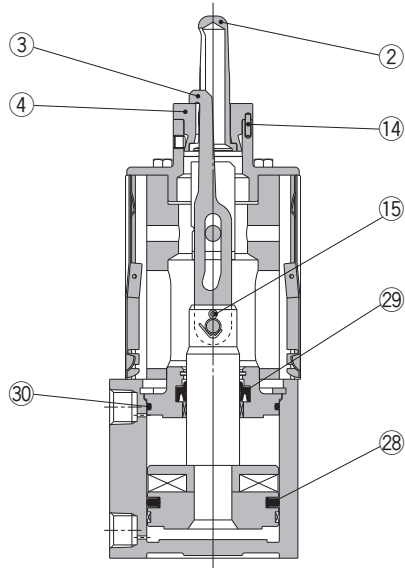

* There's no seal kit for CKQPK50.

* The numbers are the same as the "Construction" of the Best Pneumatics No.3 Series CKQ□K/CLKQ□K.

Seal Kit List

No.	Description	Material	Note
27	Piston seal	NBR	
28	Rod seal		
29	Tube gasket		

Replacement Parts: Seal Kit

Kit no.	Content
CQ2B50-PS	Set of nos. above. 27, 28, 29

* Consult SMC for maintenance service. Seal kit for maintenance of the CLKQ□ series with lock is not available.

Replacement Parts: Grease Pack

Grease pack part no.	Content
GR-S-010	Grease 10 g (Lithium)

* Consult SMC when replacing the actuating cylinders.

Seal Kit List

No.	Description	Material	Note
28	Piston seal	NBR	
29	Rod seal		
30	Tube gasket		

Replacement Parts: Seal Kit

Kit no.	Content
CQ2B50-PS	Set of nos. above. 28, 29, 30

* Consult SMC for maintenance service. Seal kit for maintenance of the CLKQ□ series with lock is not available.

Replacement Parts: Grease Pack

Grease pack part no.	Content
GR-S-010	Grease 10 g (Lithium)

* Consult SMC when replacing the actuating cylinders.

Guide Pins Assembly List

No.	Description	Material	Note
2, 4	Guide pins assembly	Stainless steel	
14	Parallel pin	Tool steel	

* Refer to page 183 for the guide pins assembly.

Clamp Arm Assembly List

No.	Description	Material	Note
3	Clamp arm	Structural steel	
15	Cotter pin	Stainless steel	

Actuators

Modular F.R.L.
Pressure Control Equipment

Air Preparation
Equipment

Industrial Filters

Replacement
Procedure

Actuators

Modular F.R.L.
Pressure Control Equipment

Industrial Filters

Series CKQGM/CKQPM

Replacement Procedure is p.374

Construction

CKQGM50

* The below figures indicate the CKQGM50-□RAL.

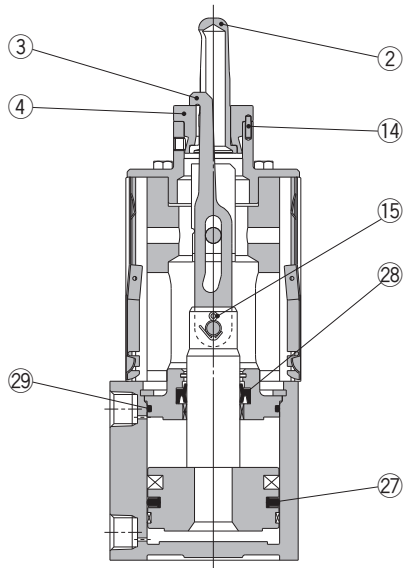

* There's no seal kit for CKQGM50.

CKQPM50

* The below figures indicate the CKQPM50-□RAL.

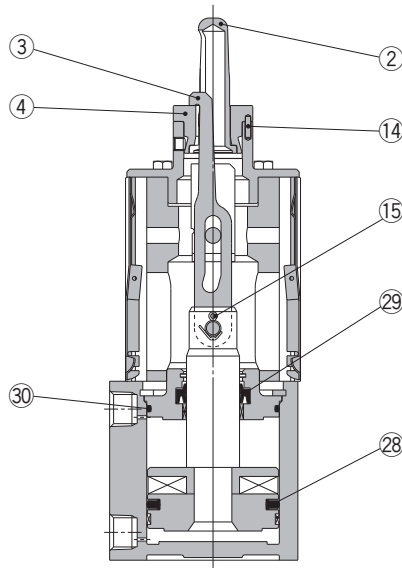

* There's no seal kit for CKQPM50.

* The numbers are the same as the "Construction" of the Best Pneumatics No.3 Series CKQ□M/CLKQ□M.

Seal Kit List

No.	Description	Material	Note
27	Piston seal	NBR	
28	Rod seal		
29	Tube gasket		

Replacement Parts: Seal Kit

Kit no.	Content
CQ2B50-PS	Set of nos. above. 27, 28, 29

* Consult SMC for maintenance service. Seal kit for maintenance of the CLKQ□ series with lock is not available.

Replacement Parts: Grease Pack

Grease pack part no.	Content
GR-S-010	Grease 10 g (Lithium)

* Consult SMC when replacing the actuating cylinders.

Seal Kit List

No.	Description	Material	Note
28	Piston seal	NBR	
29	Rod seal		
30	Tube gasket		

Replacement Parts: Seal Kit

Kit no.	Content
CQ2B50-PS	Set of nos. above. 28, 29, 30

* Consult SMC for maintenance service. Seal kit for maintenance of the CLKQ□ series with lock is not available.

Replacement Parts: Grease Pack

Grease pack part no.	Content
GR-S-010	Grease 10 g (Lithium)

* Consult SMC when replacing the actuating cylinders.

Guide Pins Assembly List

No.	Description	Material	Note
2, 4	Guide pins assembly	Stainless steel	
14	Parallel pin	Tool steel	

* Refer to page 183 for the guide pins assembly.

Clamp Arm Assembly List

No.	Description	Material	Note
3	Clamp arm	Structural steel	
15	Cotter pin	Stainless steel	

Series CKQG/CKQP

Guide Pins Assembly, Clamp Arm Assembly Kit Number

Guide Pins Assembly

Kit no.	Content and quantity		Applicable hole diameter and type
	Guide pins assembly	Parallel pin	
CKQG-R125	1	1	For ϕ 13 hole (Round/Without Shim)
CKQG-R127	1	1	
CKQG-R128	1	1	
CKQG-R129	1	1	
CKQG-R130	1	1	
CKQG-R125S	1	1	For ϕ 13 hole (Round/With Shim)
CKQG-R127S	1	1	
CKQG-R128S	1	1	
CKQG-R129S	1	1	
CKQG-R130S	1	1	
CKQG-R145	1	1	For ϕ 15 hole (Round/Without Shim)
CKQG-R147	1	1	
CKQG-R148	1	1	
CKQG-R149	1	1	
CKQG-R150	1	1	
CKQG-R145S	1	1	For ϕ 15 hole (Round/With Shim)
CKQG-R147S	1	1	
CKQG-R148S	1	1	
CKQG-R149S	1	1	
CKQG-R150S	1	1	
CKQG-R155	1	1	For ϕ 16 hole (Round/Without Shim)
CKQG-R157	1	1	
CKQG-R158	1	1	
CKQG-R159	1	1	
CKQG-R160	1	1	
CKQG-R155S	1	1	For ϕ 16 hole (Round/With Shim)
CKQG-R157S	1	1	
CKQG-R158S	1	1	
CKQG-R159S	1	1	
CKQG-R160S	1	1	
CKQG-R175	1	1	For ϕ 18 hole (Round/Without Shim)
CKQG-R177	1	1	
CKQG-R178	1	1	
CKQG-R179	1	1	
CKQG-R180	1	1	
CKQG-R175S	1	1	For ϕ 18 hole (Round/With Shim)
CKQG-R177S	1	1	
CKQG-R178S	1	1	
CKQG-R179S	1	1	
CKQG-R180S	1	1	
CKQG-D175	1	1	For ϕ 18 hole (Diamond/Without Shim)
CKQG-D177	1	1	
CKQG-D178	1	1	
CKQG-D179	1	1	
CKQG-D180	1	1	
CKQG-D175S	1	1	For ϕ 18 hole (Diamond/With Shim)
CKQG-D177S	1	1	
CKQG-D178S	1	1	
CKQG-D179S	1	1	
CKQG-D180S	1	1	
CKQG-R195	1	1	For ϕ 20 hole (Round/Without Shim)
CKQG-R197	1	1	
CKQG-R198	1	1	
CKQG-R199	1	1	
CKQG-R200	1	1	
CKQG-R195S	1	1	For ϕ 20 hole (Round/With Shim)
CKQG-R197S	1	1	
CKQG-R198S	1	1	
CKQG-R199S	1	1	
CKQG-R200S	1	1	

Kit no.	Content and quantity		Applicable hole diameter and type
	Guide pins assembly	Parallel pin	
CKQG-D195	1	1	For ϕ 20 hole (Diamond/Without Shim)
CKQG-D197	1	1	
CKQG-D198	1	1	
CKQG-D199	1	1	
CKQG-D200	1	1	
CKQG-D195S	1	1	For ϕ 20 hole (Diamond/With Shim)
CKQG-D197S	1	1	
CKQG-D198S	1	1	
CKQG-D199S	1	1	
CKQG-D200S	1	1	
CKQG-R245	1	1	For ϕ 25 hole (Round/Without Shim)
CKQG-R247	1	1	
CKQG-R248	1	1	
CKQG-R249	1	1	
CKQG-R250	1	1	
CKQG-R245S	1	1	For ϕ 25 hole (Round/With Shim)
CKQG-R247S	1	1	
CKQG-R248S	1	1	
CKQG-R249S	1	1	
CKQG-R250S	1	1	
CKQG-D245	1	1	For ϕ 25 hole (Diamond/Without Shim)
CKQG-D247	1	1	
CKQG-D248	1	1	
CKQG-D249	1	1	
CKQG-D250	1	1	
CKQG-D245S	1	1	For ϕ 25 hole (Diamond/With Shim)
CKQG-D247S	1	1	
CKQG-D248S	1	1	
CKQG-D249S	1	1	
CKQG-D250S	1	1	
CKQG-R295	1	1	For ϕ 30 hole (Round/Without Shim)
CKQG-R297	1	1	
CKQG-R298	1	1	
CKQG-R299	1	1	
CKQG-R300	1	1	
CKQG-R295S	1	1	For ϕ 30 hole (Round/With Shim)
CKQG-R297S	1	1	
CKQG-R298S	1	1	
CKQG-R299S	1	1	
CKQG-R300S	1	1	
CKQG-D295	1	1	For ϕ 30 hole (Diamond/Without Shim)
CKQG-D297	1	1	
CKQG-D298	1	1	
CKQG-D299	1	1	
CKQG-D300	1	1	
CKQG-D295S	1	1	For ϕ 30 hole (Diamond/With Shim)
CKQG-D297S	1	1	
CKQG-D298S	1	1	
CKQG-D299S	1	1	
CKQG-D300S	1	1	

Clamp Arm Assembly

Kit no.	Content and quantity		Applicable hole diameter
	Clamp arm	Cotter pin	
CKQG-13A	1	1	For ϕ 13 hole
CKQG-15A	1	1	For ϕ 15 hole
CKQG-16A	1	1	For ϕ 16 hole
CKQG-18A	1	1	For ϕ 18 hole
CKQG-20A	1	1	For ϕ 20 hole
CKQG-25A	1	1	For ϕ 25 hole
CKQG-30A	1	1	For ϕ 30 hole

Actuators

Modular F.R.L.
Pressure Control Equipment

Air Preparation
Equipment

Industrial Filters

Replacement
Procedure

Actuators

Modular F.R.L.
Pressure Control Equipment

Industrial Filters

Pin Clamp Cylinder/Compact Cylinder Type

Series *CKQG32*

Construction

CKQG□32-100R□H-X2082

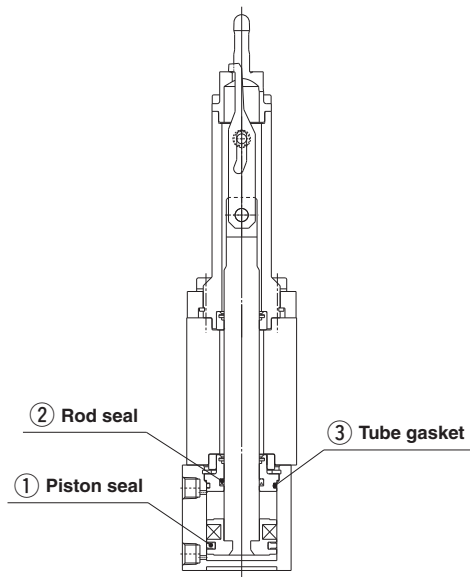

Replacement Parts: Seal Kit

Kit No.	Contents
CQ2B32-PS	① Piston seal ② Rod seal ③ Tube gasket

* Seal kit includes ①, ②, ③. Since the seal kit does not include a grease pack, order the "Grease Pack" separately.

Replacement Parts: Grease Pack

Kit No.	Contents
GR-S-010	Grease 10 g

* Consult with SMC when replacing the actuating cylinders.

Pin Clamp Cylinder/Plate Cylinder Type

Series CKU32

Construction

CKU32-120R□L-X2091

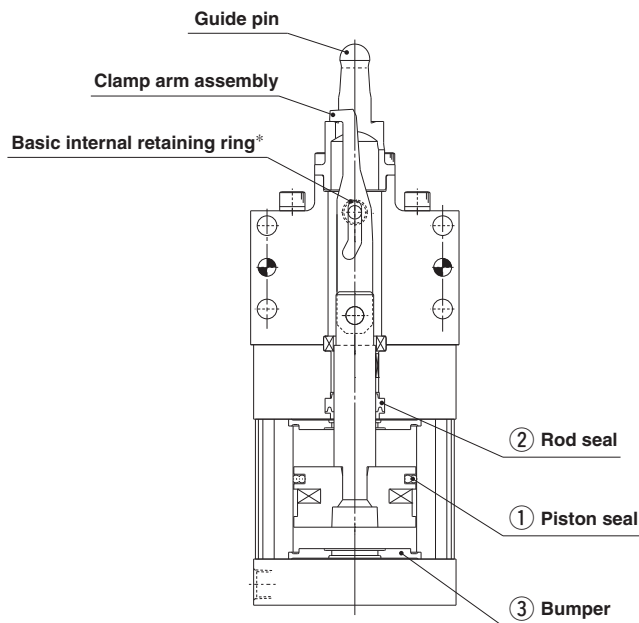

Replacement Parts: Seal Kit

Kit No.	Contents
MUB32-PS	① Piston seal ② Rod seal ③ Bumper

* Seal kit includes ①, ②, ③. Since the seal kit does not include a grease pack, order the "Grease Pack" separately.

Replacement Parts: Grease Pack

Kit No.	Contents
GR-S-010	Grease 10 g

* Consult with SMC when replacing the actuating cylinders.

Actuators

Modular F.R.L.
Pressure Control Equipment

Air Preparation
Equipment

Industrial Filters

Replacement
Procedure

Actuators

Modular F.R.L.
Pressure Control Equipment

Industrial Filters

Series CKG1/CKP1 ø40, ø50, ø63

Construction

CKG1□40, 50, 63 Built-in standard magnet type/With magnetic field resistant auto switch

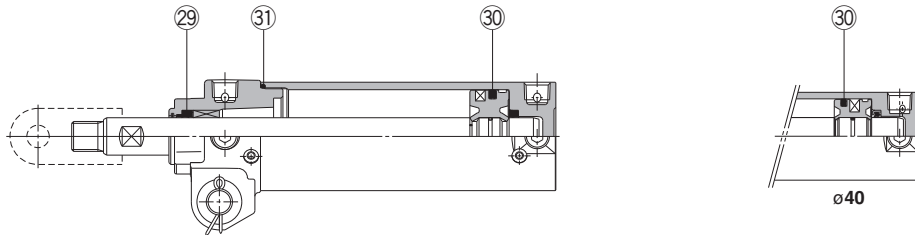

* The numbers are the same as the "Construction" of the Best Pneumatics No.3 Series CKG1.

Seal Kit List

No.	Description	Material	Note
29	Rod seal	NBR	
30	Piston seal		
31	Tube gasket		

Replacement Parts: Seal Kit

Bore size (mm)	Order no.	Contents
40	CK1A40-PS	Set of left nos. 29, 30, 31
50	CK1A50-PS	
63	CK1A63-PS	

Note) The seal kit does not come with a grease pack, so please order it separately.

Grease pack part no.: GR-S-010 (compatible with all sizes)

CKP1□40, 50, 63 Built-in strong magnet type/With magnetic field resistant auto switch

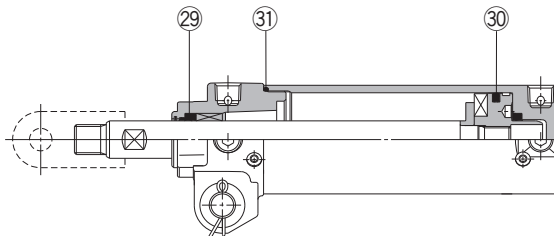

* The numbers are the same as the "Construction" of the Best Pneumatics No.3 Series CKP1.

Seal Kit List

No.	Description	Material	Note
29	Rod seal	NBR	
30	Piston seal		
31	Tube gasket		

Replacement Parts: Seal Kit

Bore size (mm)	Order no.	Contents
40	CK1A40-PS	Set of left nos. 29, 30, 31
50	CK1A50-PS	
63	CK1A63-PS	

Note) The seal kit does not come with a grease pack, so please order it separately.

Grease pack part no.: GR-S-010 (compatible with all sizes)

Clamp Cylinder/Basic Type: Built-in Standard Magnet Type
Magnetic Field Resistant Auto Switch (Band Mounting Style)

Series CK1/CKG1

ø40, ø50, ø63

Construction

CK1□40, 50, 63 Basic type/CKG1□40, 50, 63 Built-in standard magnet type

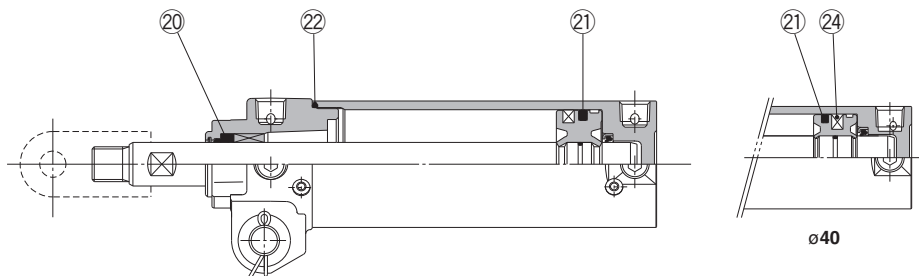

* The numbers are the same as the "Construction" of the Best Pneumatics No.3 Series CK□1.

Seal Kit List

No.	Description	Material	Note
⑳	Rod seal	NBR	
㉑	Piston seal		
㉒	Tube gasket		

Replacement Parts: Seal Kit

Bore size (mm)	Order no.	Contents
40	CK1A40-PS	Set of left nos. ㉑, ㉒, ㉓
50	CK1A50-PS	
63	CK1A63-PS	

Note) The seal kit does not come with a grease pack, so please order it separately.

Grease pack part no.: GR-S-010 (compatible with all sizes)

Actuators

Modular F.R.L.
Pressure Control Equipment

Air Preparation
Equipment

Industrial Filters

Replacement
Procedure

Actuators

Modular F.R.L.
Pressure Control Equipment

Industrial Filters

Stopper Cylinder/Fixed Mounting Height

Series RSQ

ø12, ø16, ø20,
ø32, ø40, ø50

Replacement
Procedure is
P.385

Construction

Roller rod end

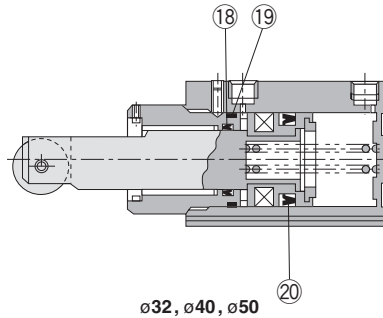
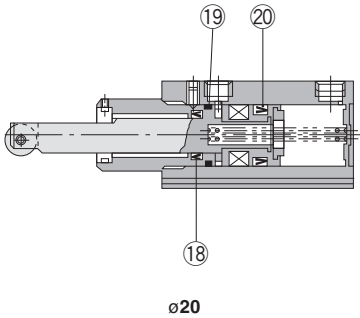
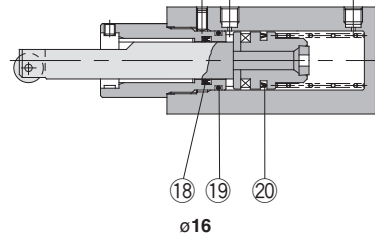
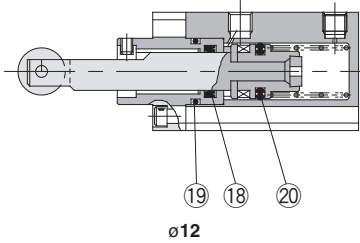

* The numbers are the same as the "Construction" of the Best Pneumatics No.3 Series RSQ.

Seal Kit List

No.	Description	Material	Note
18	Rod seal	NBR	
19	Gasket		
20	Piston seal		

Replacement Parts: Seal Kit

Bore size (mm)	Kit no.			Contents
	Double acting	Double acting with spring loaded	Single acting	
12	RSQ12D-PS	RSQ12T-PS		Set of left nos. 18, 19, 20
16	RSQ16D-PS	RSQ16B-PS	RSQ16T-PS	
20	RSQ20D-PS	RSQ20B-PS	RSQ20T-PS	
32	RSQ32D-PS	RSQ32B-PS	RSQ32T-PS	
40	RSQ40D-PS	RSQ40B-PS	RSQ40T-PS	
50	RSQ50D-PS	RSQ50B-PS	RSQ50T-PS	

* Seal kit includes 18, 19, 20. Order the seal kit, based on each bore size.

* Since the seal kit does not include a grease pack, order it separately.

Grease pack part no.: GR-S-010 (10 g)

Replacement Parts: Shock Absorber

Bore size (mm)	Kit no.
32	RB1007-X225
40, 50	RB1407-X552

Series RSG $\varnothing 40, \varnothing 50$

Replacement
Procedure is
P.385

Construction

Roller rod end

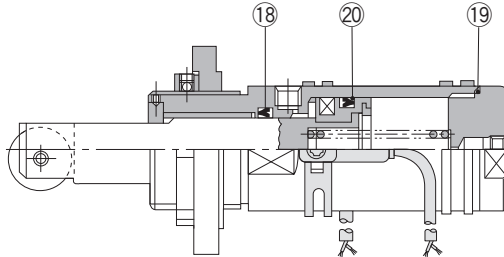

* The numbers are the same as the "Construction" of the Best Pneumatics No.3 Series RSG.

Seal Kit List

No.	Description	Material	Note
18	Rod seal	NBR	Only for double acting and double acting with spring loaded.
19	Gasket		
20	Piston seal		

Replacement Parts: Seal Kit

Bore size (mm)	Kit no.			Contents
	Double acting	Double acting with spring loaded	Single acting	
40	RSG40D-PS	RSG40B-PS	RSG40T-PS	Set of left nos. 18, 19, 20
50	RSG50D-PS	RSG50B-PS	RSG50T-PS	

* Seal kit includes 18, 19, 20. Order the seal kit, based on each bore size.
* Since the seal kit does not include a grease pack, order it separately.

Grease pack part no.: GR-S-010 (10 g)

Replacement Parts: Shock Absorber

Bore size (mm)	Kit no.
40, 50	RB1407-X552

Actuators

Modular F.R.L.
Pressure Control Equipment

Air Preparation
Equipment

Industrial Filters

Replacement
Procedure

Actuators

Modular F.R.L.
Pressure Control Equipment

Industrial Filters

Heavy Duty Stopper Cylinder

Series RSH $\varnothing 20, \varnothing 32$

Replacement
Procedure is
P.387

Construction

$\varnothing 20, \varnothing 32$
Double acting (DL, DM)

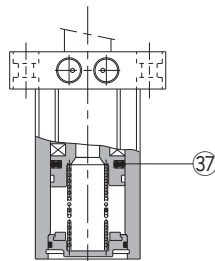
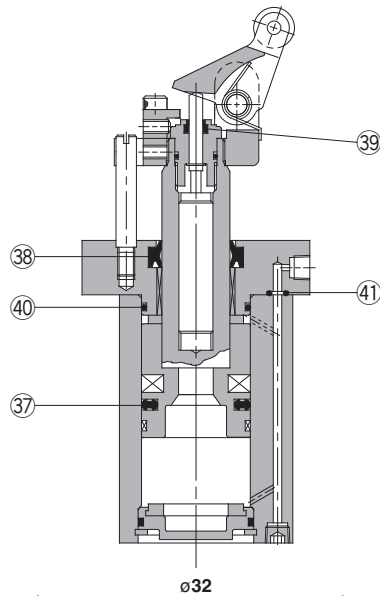

Double acting spring type
(BL, BM)

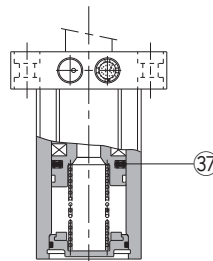

Single acting
(TL, TM)

* The numbers are the same as the "Construction" of the Best Pneumatics No.3 Series RSH/RS1H.

Seal Kit List

No.	Description	Material	Note
37	Piston seal	NBR	
38	Rod seal		
39	Scraper		
40	Tube gasket		
41	O-ring		

38 is a non-replaceable part, so it is not included in the seal kit.

Replacement Parts: Shock Absorber

Bore size (mm)	Order no.
20	RSH-R20
32	RSH-R32

Replacement Parts: Seal Kit

Bore size (mm)	Kit no.			Contents
	Double acting	Double acting spring type	Single acting	
20	RSH20D-PS	RSH20T-PS		Set of left nos.
32	RSH32D-PS	RSH32T-PS		37, 39, 40, 41

* Seal kit includes 37, 39, 40, 41 for $\varnothing 20$ to $\varnothing 32$. Order the seal kit based on each bore size.

* Since the seal kit does not include a grease pack, order it separately.
Grease pack part no.: GR-S-010 (10 g)

Heavy Duty Stopper Cylinder

Series RS2H

ø50, ø63, ø80

Replacement
Procedure is
P.387

Construction

Double acting (DL, DM)

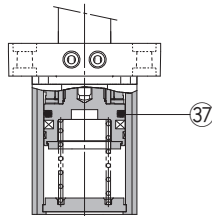
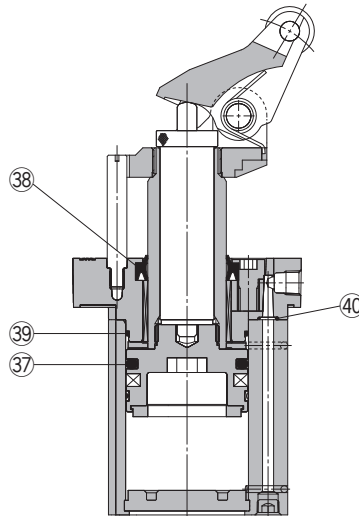

Double acting spring type
(BL, BM)

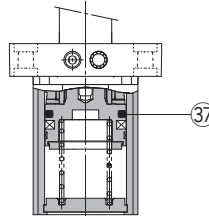

Single acting
(TL, TM)

* The numbers are the same as the "Construction" of the RS2H series catalog (CAT.ES20-216).

Seal Kit List

No.	Description	Material	Note
37	Piston seal	NBR	
38	Rod seal		
39	Tube gasket		
40	O-ring		

38 is a non-replaceable part, so it is not included in the seal kit.

Replacement Parts: Seal Kit

Bore size (mm)	Kit no.			Contents
	Double acting	Double acting spring type	Single acting	
50	RS2H50D-PS	RS2H50T-PS		Set of left nos. 37, 39, 40
63	RS2H63D-PS	RS2H63T-PS		
80	RS2H80D-PS	RS2H80T-PS		

* Seal kit includes 37, 39, 40 for ø50 to ø80. Order the seal kit based on each bore size.

* Since the seal kit does not include a grease pack, order it separately.

Grease pack part no.: GR-S-010 (10 g)

Replacement Parts: Shock Absorber

Bore size (mm)	Order no.
50	RS2H-R50
63	RS2H-R63
80	RS2H-R80

Actuators

Modular F.R.L.
Pressure Control Equipment

Air Preparation
Equipment

Industrial Filters

Replacement
Procedure

Actuators

Modular F.R.L.
Pressure Control Equipment

Industrial Filters

Series MIW

ø8, ø12, ø20, ø25, ø32



Construction

Option

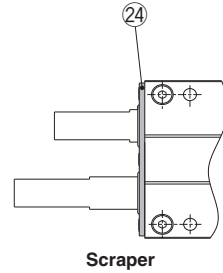
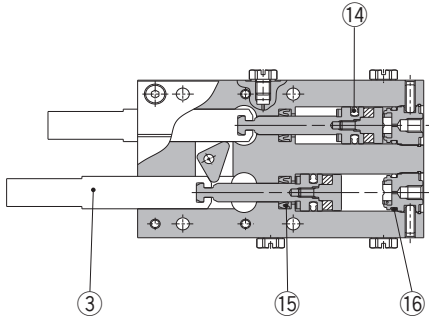

* The numbers are the same as the "Construction" of the Best Pneumatics No.3 Series MIW/MIS.

Seal Kit List

No.	Description	Material	Note
3	Finger	Carbon steel	Heat treatment/Special treatment
14	Piston seal	NBR	
15	Rod seal	NBR	
16	Gasket	NBR	

3 is a not included in the seal kit. Order it as required with by individual part numbers.

Option: Scraper

No.	Description	Material	Note
24	Scraper	Stainless steel + NBR	

Replacement Parts

Model	Description	Finger			Seal kit	Scraper assembly	Grease pack
		Standard	Tapped on upper and lower faces	Tapped on all faces			
MIW8-8D	MI-A0801-8	MI-A0802-8	MI-A0803-8	MIW8-PS	MIW-A0804	MH-G01 (contents quantity 30 g)	
MIW12-12D	MI-A1201-12	MI-A1202-12	MI-A1203-12	MIW12-PS	MIW-A1204		
MIW20-20D	MI-A2001-20	MI-A2002-20	MI-A2003-20	MIW20-PS	MIW-A2004		
MIW25-25D	MI-A2501-25	MI-A2502-25	MI-A2503-25	MIW25-PS	MIW-A2504		
MIW32-32D	MI-A3201-32	MI-A3202-32	MI-A3203-32	MIW32-PS	MIW-A3204		
Main parts No.		③ (1 pc.)			⑭, ⑮, ⑯	⑳	

Series MIS

ø8, ø12, ø20, ø25, ø32



Construction

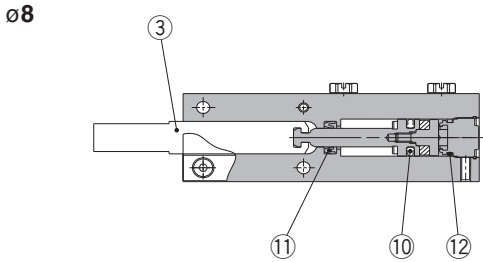

ø25, ø32

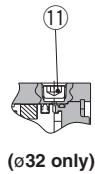

Option

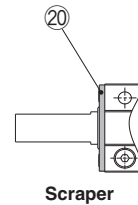

Scraper

* The numbers are the same as the "Construction" of the Best Pneumatics No.3 Series MIW/MIS.

Seal Kit List

No.	Description	Material	Note
3	Finger	Carbon steel	Heat treatment/Special treatment
10	Piston seal	NBR	
11	Rod seal	NBR	
12	Gasket	NBR	

3 is a not included in the seal kit. Order it as required with by individual part numbers.

Option: Scraper

No.	Description	Material	Note
20	Scraper	Stainless steel + NBR	

Replacement Parts

Model	Description	Finger			Seal kit	Scraper assembly	Grease pack
		Standard	Tapped on upper and lower faces	Tapped on all faces			
MIS8-10D		MI-A0801-10	MI-A0802-10	MI-A0803-10	MIS8-PS	MIS-A0804	MH-G01 (contents quantity 30 g)
MIS8-20D		MI-A0801-20	MI-A0802-20	MI-A0803-20			
MIS12-10D		MI-A1201-10	MI-A1202-10	MI-A1203-10			
MIS12-20D		MI-A1201-20	MI-A1202-20	MI-A1203-20	MIS12-PS	MIS-A1204	
MIS12-30D		MI-A1201-30	MI-A1202-30	MI-A1203-30			
MIS20-10D		MI-A2001-10	MI-A2002-10	MI-A2003-10			
MIS20-20D		MI-A2001-20	MI-A2002-20	MI-A2003-20	MIS20-PS	MIS-A2004	
MIS20-30D		MI-A2001-30	MI-A2002-30	MI-A2003-30			
MIS25-30D		MI-A2501-30	MI-A2502-30	MI-A2503-30			
MIS25-50D		MI-A2501-50	MI-A2502-50	MI-A2503-50	MIS25-PS	MIS-A2504	
MIS32-30D		MI-A3201-30	MI-A3202-30	MI-A3203-30			
MIS32-50D		MI-A3201-50	MI-A3202-50	MI-A3203-50			
Main parts No.		3 (1 pc.)			10, 11, 12	20	

Actuators

Modular F.R.L.
Pressure Control Equipment

Air Preparation
Equipment

Industrial Filters

Replacement
Procedure

Actuators

Modular F.R.L.
Pressure Control Equipment

Industrial Filters

Series CVQ

ø32, ø40, ø50, ø63



Construction

Basic type

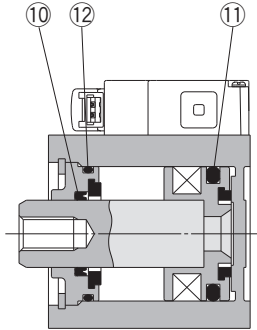

* The Numbers are the same as the "Construction" of the CVQ series catalog (CAT.ES20-182).

Seal Kit List

No.	Description	Material	Note
⑩	Rod seal	NBR	
⑪	Piston seal		
⑫	Gasket		

Replacement Parts: Seal Kit

Bore size (mm)	Order no.	Contents
32	CQ2B32-PS	Set of left nos. ⑩, ⑪, ⑫
40	CQ2B40-PS	
50	CQ2B50-PS	
63	CQ2B63-PS	

* Seal kit includes ⑩, ⑪, ⑫. Order the seal kit, based on each bore size.
* Grease pack must be ordered separately as it is not included in the seal kit.

Grease pack part no.: GR-S-010 (10 g)

Series CVM5

ø20, ø25, ø32, ø40

Replacement
Procedure is
P.280

Construction

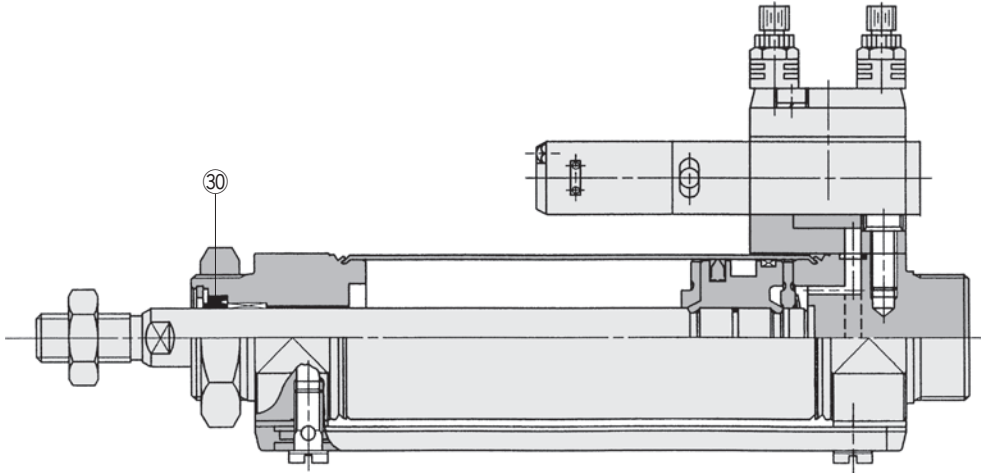

* The numbers are the same as the "Construction" of the Best Pneumatics No.3 Series CVM5.

Seal Kit List

No.	Description	Material	Note
30	Rod seal	NBR	

Replacement Parts: Seal Kit

Bore size (mm)	Kit no.	Contents
20	KB01587	
25	KB01588	
32	KB01590	
40	KB01592	

* Since the seal kit does not include a grease pack, order it separately.
Grease pack part no.: GR-S-010 (10 g)

Actuators

Modular F.R.L.
Pressure Control Equipment

Air Preparation
Equipment

Industrial Filters

Replacement
Procedure

Actuators

Modular F.R.L.
Pressure Control Equipment

Industrial Filters

Series CVM5K

∅20, ∅25
∅32, ∅40

Replacement
Procedure is
P.280

Construction

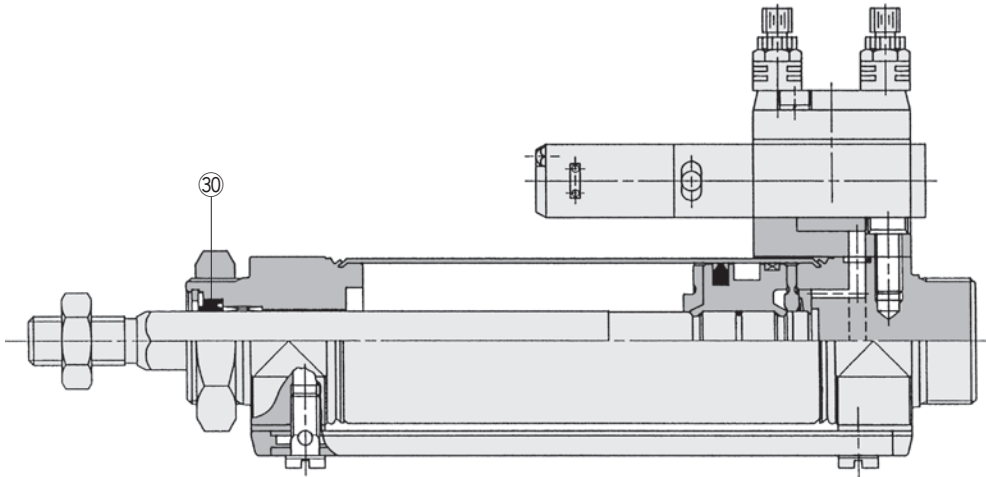

* The numbers are the same as the "Construction" of the Best Pneumatics No.3 Series CVM5K.

Seal Kit List

No.	Description	Material	Note
30	Rod seal	NBR	

Replacement Parts: Seal Kit

Bore size (mm)	Kit no.	Contents
20	KB00564	
25	KB00552	
32	KB00554	
40	KB00555	

* Since the seal kit does not include a grease pack, order it separately.
Grease pack part no.: GR-S-010 (10 g)

Series CVM3

ø20, ø25, ø32, ø40

Replacement
Procedure is
P.280

Construction

Spring return

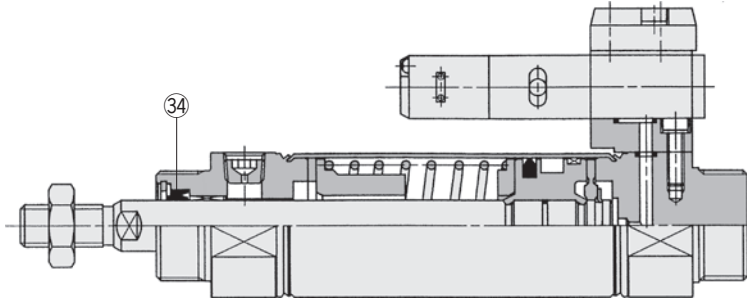

Spring extend

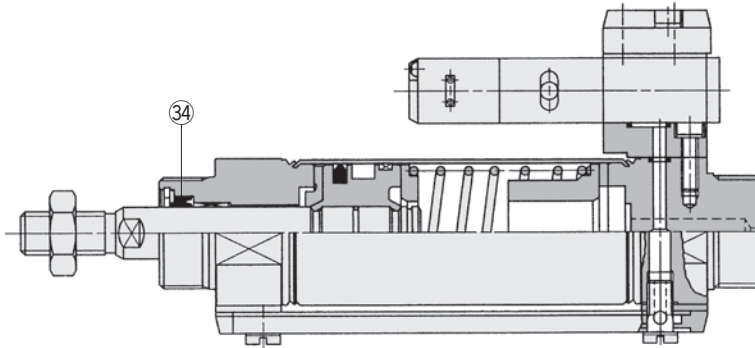

* The numbers are the same as the "Construction" of the Best Pneumatics No.3 Series CVM3.

Seal Kit List

No.	Description	Material	Note
34	Rod seal	NBR	

Replacement Parts: Seal Kit

Bore size (mm)	Kit no.	Contents
20	KB01587	
25	KB01588	
32	KB01590	
40	KB01592	

* Since the seal kit does not include a grease pack, order it separately.
Grease pack part no.: GR-S-010 (10 g)

Actuators

Modular F.R.L.
Pressure Control Equipment

Air Preparation
Equipment

Industrial Filters

Replacement
Procedure

Actuators

Modular F.R.L.
Pressure Control Equipment

Industrial Filters

Series CVM3K

ø20, ø25
ø32, ø40

Replacement
Procedure is
P.280

Construction

Spring return

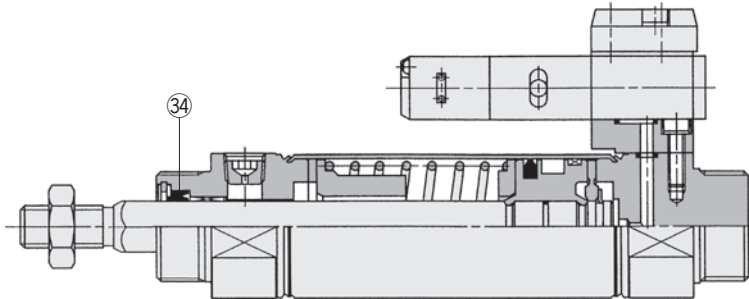

Spring extend

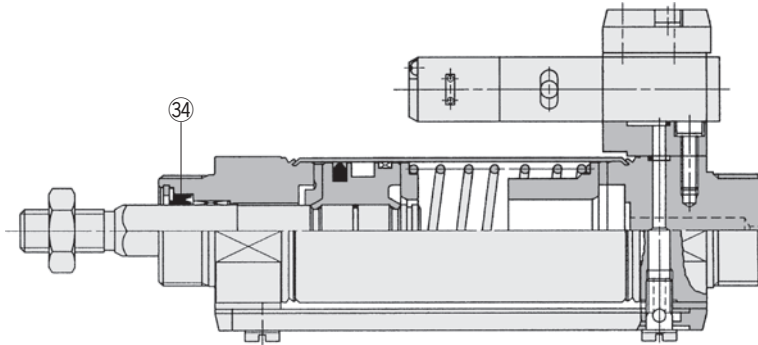

* The numbers are the same as the "Construction" of the Best Pneumatics No.3 Series CVM3K.

Seal Kit List

No.	Description	Material	Note
34	Rod seal	NBR	

Replacement Parts: Seal Kit

Bore size (mm)	Kit no.	Contents
20	KB00564	
25	KB00552	
32	KB00554	
40	KB00555	

* Since the seal kit does not include a grease pack, order it separately.
Grease pack part no.: GR-S-010 (10 g)

Valve Mounted Cylinder/Double Acting

Series CV3

Lube, Non-lube type:
 ø40, ø50, ø63, ø80, ø100

Construction

Lube type

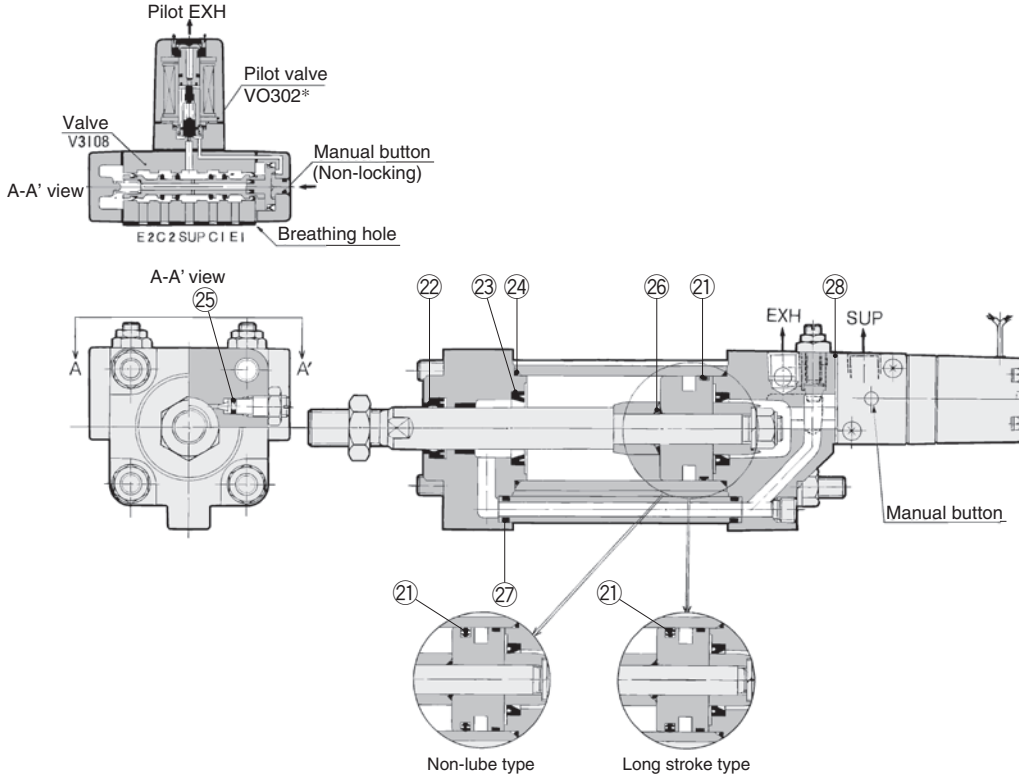

* The numbers are the same as the "Construction" of the Best Pneumatics No.3 Series CV3.

Seal Kit List

No.	Description	Material	Note
21	Piston seal	NBR	23 and 26 are non-replaceable parts, so they are not included in the seal kit.
22	Rod seal		
23	Cushion seal		
24	Cylinder tube gasket		
25	Cushion valve seal		
26	Piston gasket		
27	Pipe gasket		
28	Head cover gasket		

Replacement Parts: Seal Kit

Bore size (mm)	Kit no.	Contents
Lube type		
40	CV3-40-PS	Set of left nos. 21, 22, 23, 25, 27, 28
50	CV3-50-PS	
63	CV3-63-PS	
80	CV3-80-PS	
100	CV3-100-PS	
Non-lube type		
40	CV3N40-PS	Set of left nos. 21, 22, 23, 25, 27, 28
50	CV3N50-PS	
63	CV3N63-PS	
80	CV3N80-PS	
100	CV3N100-PS	

* Seal kit includes 21, 22, 24, 25, 27, 28. Order the seal kit, based on each bore size.

* Seal kit includes a grease pack (ø40, ø50: 10 g, ø63, ø80: 20 g, ø100: 30 g).

Order with the following part number when only the grease pack is needed.

Grease pack part no.: GR-S-010 (10 g), GR-S-020 (20 g)

Actuators

Modular F.R.L.
Pressure Control Equipment

Air Preparation Equipment

Industrial Filters

Replacement Procedure

Actuators

Modular F.R.L.
Pressure Control Equipment

Industrial Filters

Valve Mounted Cylinder/Non-rotating Rod Type: Double Acting

Series CV3K

Non-lube Type: $\phi 40$, $\phi 50$, $\phi 63$

Construction

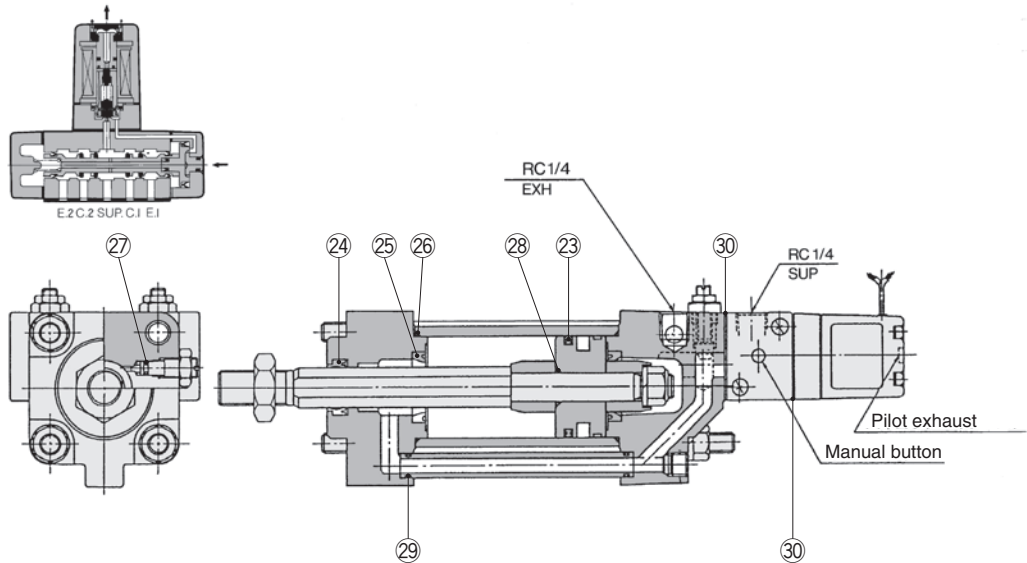

* The numbers are the same as the "Construction" of the Best Pneumatics No.3 Series CV3K.

Seal Kit List

No.	Description	Material	Note
23	Piston seal	NBR	25 and 28 are non-replaceable parts, so they are not included in the seal kit.
24	Rod seal		
25	Cushion seal		
26	Cylinder tube gasket		
27	Cushion valve seal		
28	Piston gasket		
29	Pipe gasket		
30	Head cover gasket		

Replacement Parts: Seal Kit

Bore size (mm)	Kit no.	Contents
40	CV3K40-PS	Set of left nos. 23, 24, 26, 27, 29, 30
50	CV3K50-PS	
63	CV3K63-PS	

* Seal kit includes 23, 24, 26, 27, 29, 30. Order the seal kit, based on each bore size.

* Seal kit includes a grease pack ($\phi 40$, $\phi 50$: 10 g, $\phi 63$ or more: 20 g). Order with the following part number when only the grease pack is needed.

Grease pack part no.: GR-S-010 (10 g), GR-S-020 (20 g)

Disassembly/Replacement

1. Please consult with SMC when the rod seal is to be replaced.

When the rod seal is to be replaced, make sure that the seal's width across flats matches that of the non-rotating guide.

A rod seal may allow air leakage depending on the position where it is installed. Therefore, please consult with SMC when a rod seal is to be replaced.

2. Do not replace the non-rotating guide.

Since the non-rotating guide is press fitted, the entire cover assembly needs to be replaced instead of a single part.

Valve Mounted Cylinder/Double Acting

Series CVS1

Lube, Non-lube Type: $\varnothing 40, \varnothing 50$
 $\varnothing 63, \varnothing 80, \varnothing 100$

Construction

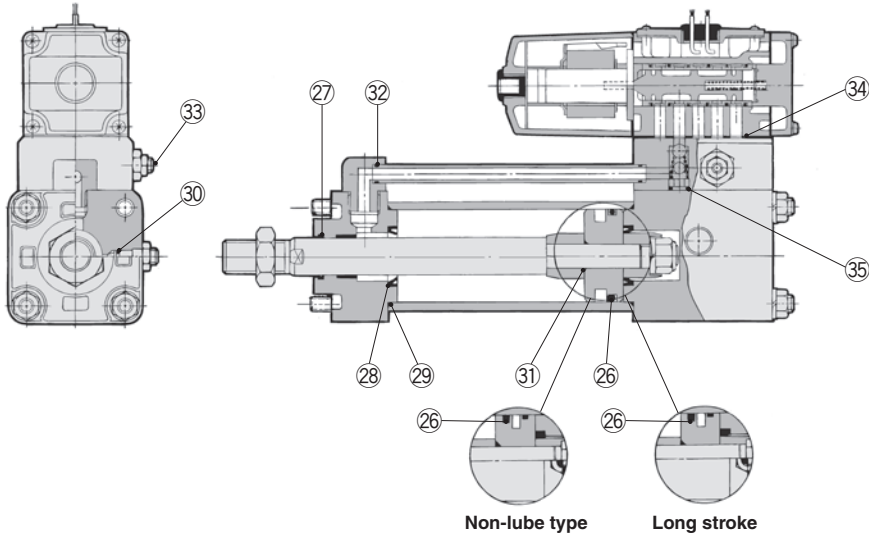

* The numbers are the same as the "Construction" of the Best Pneumatics No.3 Series CVS1.

Seal Kit List

No.	Description	Material	Note
26	Piston seal	NBR	28, 31, 33 and 34 are non-replaceable parts, so they are not included in the seal kit.
27	Rod seal		
28	Cushion seal		
29	Cylinder tube gasket		
30	Cushion valve seal		
31	Piston gasket		
32	Pipe gasket		
33	Speed adjustment valve seal		
34	Gasket		
35	Valve port gasket		

Replacement Parts: Seal Kit

Bore size (mm)	Kit no.	Contents
Lube type		
40	CVS1-40-PS	Set of left nos. 26, 27, 29, 30, 32, 35
50	CVS1-50-PS	
63	CVS1-63-PS	
80	CVS1-80-PS	
100	CVS1-100-PS	
Non-lube type		
40	CVS1N40-PS	Set of left nos. 26, 27, 29, 30, 32, 35
50	CVS1N50-PS	
63	CVS1N63-PS	
80	CVS1N80-PS	
100	CVS1N100-PS	

* Seal kit includes 26, 27, 29, 30, 32, 35. Order the seal kit, based on each bore size.

* Seal kit includes a grease pack ($\varnothing 40, \varnothing 50$: 10 g, $\varnothing 63, \varnothing 80$: 20 g, $\varnothing 100$: 30 g).

Order with the following part number when only the grease pack is needed.

Grease pack part no.: GR-S-010 (10 g), GR-S-020 (20 g)

Actuators

Modular F.R.L.
Pressure Control Equipment

Air Preparation
Equipment

Industrial Filters

Replacement
Procedure

Actuators

Modular F.R.L.
Pressure Control Equipment

Industrial Filters

Series CVS1K

Non-lube Type:
 ø40, ø50, ø63

Construction

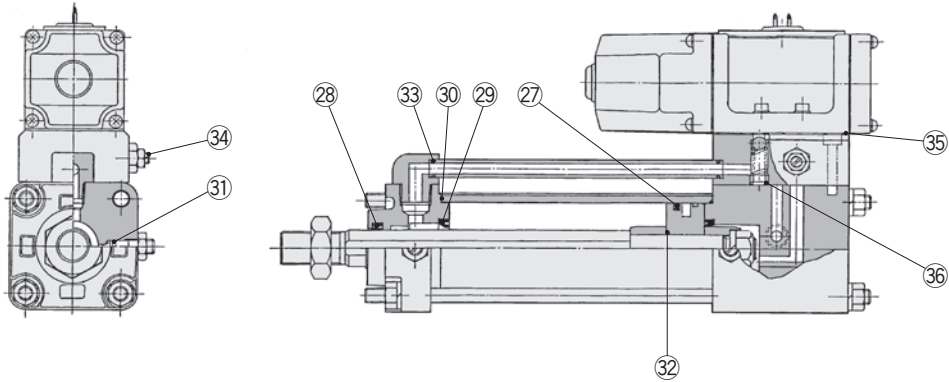

* The numbers are the same as the "Construction" of the Best Pneumatics No.3 Series CVS1K.

Seal Kit List

No.	Description	Material	Note
27	Piston seal	NBR	29, 32, 34 and 35 are non-replaceable parts, so they are not included in the seal kit.
28	Rod seal		
29	Cushion seal		
30	Cylinder tube gasket		
31	Cushion valve seal		
32	Piston gasket		
33	Pipe gasket		
34	Speed adjustment valve seal		
35	Gasket		
36	Valve port gasket		

Replacement Parts: Seal Kit

Bore size (mm)	Kit no.	Contents
40	CVS1K40-PS	Set of left nos. 27, 28, 30, 31, 33, 36
50	CVS1K50-PS	
63	CVS1K63-PS	

* Seal kit includes 27, 28, 30, 31, 33, 36. Order the seal kit, based on each bore size.

* Seal kit includes a grease pack (ø40, ø50: 10 g, ø63 or more: 20 g). Order with the following part number when only the grease pack is needed.

Grease pack part no.: GR-S-010 (10 g), GR-S-020 (20 g)

Disassembly/Replacement

1. Please consult with SMC when the rod seal is to be replaced.

When the rod seal is to be replaced, make sure that the seal's width across flats matches that of the non-rotating guide.

A rod seal may allow air leakage depending on the position where it is installed. Therefore, please consult with SMC when a rod seal is to be replaced.

2. Do not replace the non-rotating guide.

Since the non-rotating guide is press fitted, the entire cover assembly needs to be replaced instead of a single part.

Compact Hydraulic Cylinder/Double Acting, Single Rod

Series CH□QB

ø20, ø32, ø40
ø50, ø63, ø80, ø100

Construction

CH□QB20

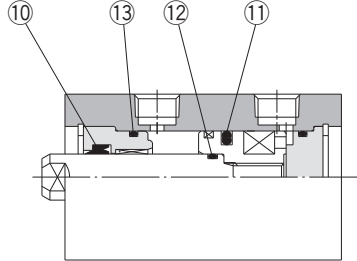

CH□QB32 to CH□QB100

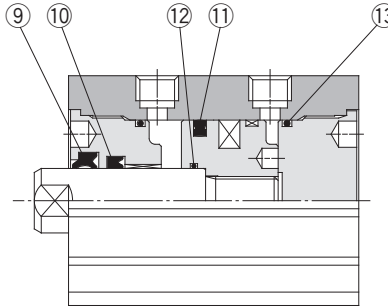

* The numbers are the same as the "Construction" of the Best Pneumatics No.8 Series CH□QB.

Seal Kit List

No.	Description	Material	Note
⑨	Scraper	NBR	12 is a non-replaceable part, so it is not included in the seal kit.
⑩	Rod seal		
⑪	Piston seal		
⑫	Piston gasket		
⑬	Tube gasket		

Replacement Parts: Seal Kit

Bore size (mm)	Seal kit no.	Content
20	CHQ20-PS	Set of left nos. ⑨, ⑩, ⑪, ⑬
32	CHQ32-PS	
40	CHQ40-PS	
50	CHQ50-PS	
63	CHQ63-PS	
80	CHQ80-PS	
100	CHQ100-PS	

* Seal kit consists of items ⑨, ⑩, ⑪ and ⑬ and can be ordered by using the seal kit number for each bore size.

* Special tool required for disassembly. Contact SMC for recommended tool designs and dimensions.

Cover Tightening Torque

Bore size (mm)	Tightening torque(N·m)
32	12.5 ± 1.2
40	74.5 ± 7.4
50	100 ± 10
63	
80	
100	411 ± 41

* Reassemble the cover with the above tightening torques.

Actuators

Modular F.R.L.
Pressure Control Equipment

Air Preparation
Equipment

Industrial Filters

Replacement
Procedure

Actuators

Modular F.R.L.
Pressure Control Equipment

Industrial Filters

Compact Hydraulic Cylinder/Double Acting, Double Rod

Series CH□QWB

ø20, ø32, ø40
ø50, ø63, ø80, ø100

Construction

CH□QWB20

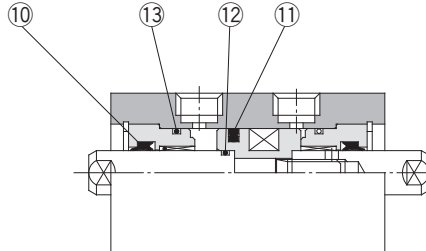

CH□QWB32 to CH□QWB100

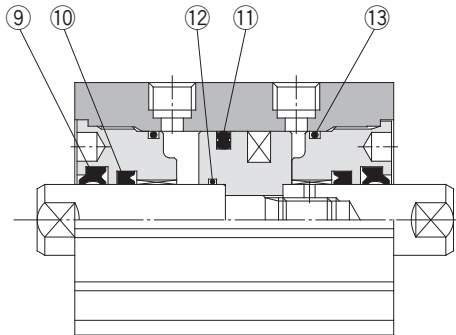

* The numbers are the same as the "Construction" of the Best Pneumatics No.8 Series CH□QWB.

Seal Kit List

No.	Description	Material	Note
⑨	Scraper	NBR	12 is a non-replaceable part, so it is not included in the seal kit.
⑩	Rod seal		
⑪	Piston seal		
12	Piston gasket		
⑬	Tube gasket		

Replacement Parts: Seal Kit

Bore size (mm)	Seal kit no.	Content
20	CHQW20-PS	Set of left nos. ⑨, ⑩, ⑪, ⑬
32	CHQW32-PS	
40	CHQW40-PS	
50	CHQW50-PS	
63	CHQW63-PS	
80	CHQW80-PS	
100	CHQW100-PS	

* Seal kit consists of items ⑨, ⑩, ⑪ and ⑬ and can be ordered by using the seal kit number for each bore size.

* Special tool required for disassembly. Contact SMC for recommended tool designs and dimensions.

Cover Tightening Torque

Bore size (mm)	Tightening torque(N-m)
32	12.5 ± 1.2
40	74.5 ± 7.4
50	100 ± 10
63	
80	
100	411 ± 41

* Reassemble the cover with the above tightening torques.

Series CH□KD

ø20, ø25
ø32, ø40
ø50, ø63
ø80, ø100

Replacement
Procedure is
P.392

Construction

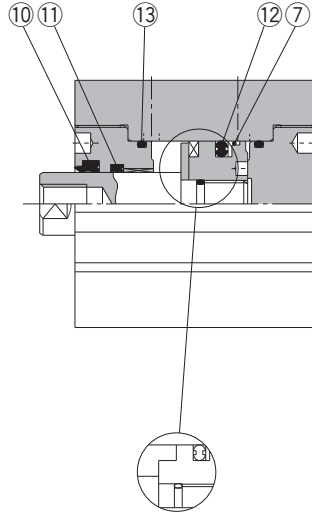

Without auto switch

* The numbers are the same as the "Construction" of the Best Pneumatics No.8 Series CH□KD.

Seal Kit List

No.	Description	Material	Note
⑦	Back-up ring	Resin	
⑩	Scraper	NBR	
⑪	Rod seal		
⑫	Piston seal		
⑬	Tube gasket		

Replacement Parts: Seal Kit

Bore size (mm)	Seal kit no.	Content
20	CHKD20-PS	Set of left nos. ⑦, ⑩, ⑪, ⑫, ⑬
25	CHKD25-PS	
32	CHKD32-PS	
40	CHKD40-PS	
50	CHKD50-PS	
63	CHKD63-PS	
80	CHKD80-PS	
100	CHKD100-PS	

* Seal kit consists of items ⑦, ⑩, ⑪, ⑫ and ⑬, and can be ordered by using the seal kit number for each bore size.

* Special tools are necessary for disassembly. Contact SMC for recommended tool designs and dimensions. Furthermore, ø80 and ø100 are tightened with a large tightening torque, so disassembly will be difficult. Contact SMC if disassembly is required.

Actuators

Modular F.R.L.
Pressure Control Equipment

Air Preparation
Equipment

Industrial Filters

Replacement
Procedure

Actuators

Modular F.R.L.
Pressure Control Equipment

Industrial Filters

Series CH□KG

ø20, ø25
ø32, ø40
ø50, ø63
ø80, ø100



Construction

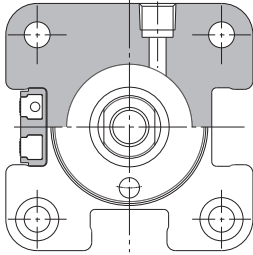

ø32 to ø100

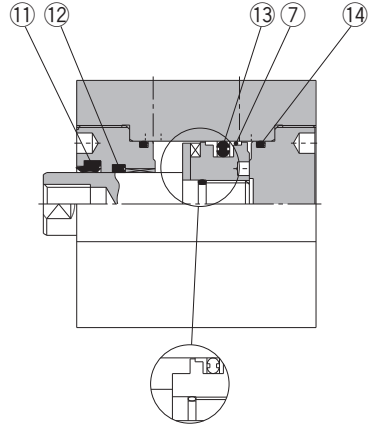

Without auto switch

* The numbers are the same as the "Construction" of the Best Pneumatics No.8 Series CH□KG.

Seal Kit List

No.	Description	Material	Note
⑦	Back-up ring	Resin	
⑪	Scraper	NBR	With back-up ring
⑫	Rod seal		
⑬	Piston seal		
⑭	Tube gasket		

Replacement Parts: Seal Kit

Bore size (mm)	Seal kit no.	Content
20	CHKG20-PS	Set of left nos. ⑦, ⑪, ⑫, ⑬, ⑭
25	CHKG25-PS	
32	CHKG32-PS	
40	CHKG40-PS	
50	CHKG50-PS	
63	CHKG63-PS	
80	CHKG80-PS	
100	CHKG100-PS	

* Seal kit consists of items ⑦, ⑪, ⑫, ⑬ and ⑭ and can be ordered by using the seal kit number for each bore size.

* Special tools are necessary for disassembly. Contact SMC for recommended tool designs and dimensions. Furthermore, ø80 and ø100 are tightened with a large tightening torque, so disassembly will be difficult. Contact SMC if disassembly is required.

Construction

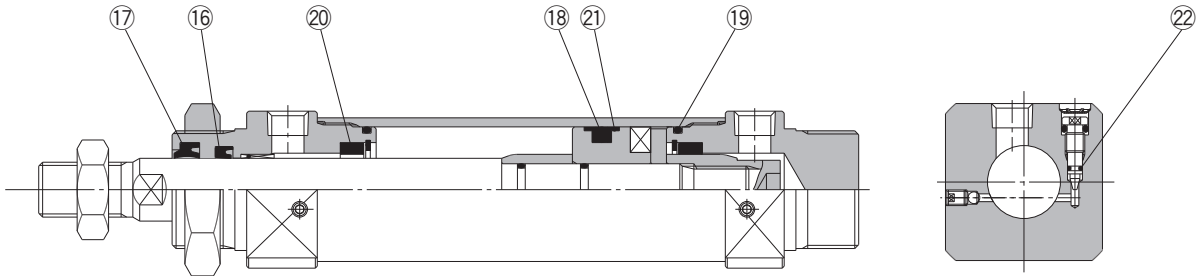

* The numbers are the same as the "Construction" of the Best Pneumatics No.8 Series CHN.

Seal Kit List

No.	Description	Material	Note
16	Rod seal	NBR	21 is a non-replaceable part, so it is not included in the seal kit.
17	Scraper	NBR	
18	Piston seal	NBR	
19	Tube gasket	NBR	
20	Cushion seal	—	
21	Back-up ring	Resin	
22	Cushion valve seal A	NBR	

Replacement Parts: Seal Kit

Bore size (mm)	Seal kit no.	Content
20	CHN20-PS	Set of left nos. (16, 17, 18, 19, 20, 22)
25	CHN25-PS	
32	CHN32-PS	
40	CHN40-PS	

* Seal kit consists of items 16 to 20 and 22 and can be ordered by using the seal kit number for each bore size.

Series CHSD

ø40, ø50, ø63
ø80, ø100



Construction

CH□SDB

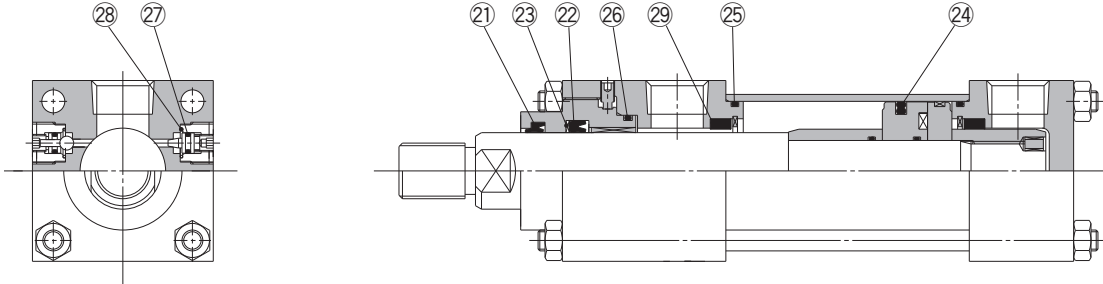

* The numbers are the same as the "Construction" of the Best Pneumatics No.8 Series CHSD.

Seal Kit List

No.	Description	Material	Note
①	Scraper	NBR	26, 27 and 28 are non-replaceable parts, so they are not included in the seal kit.
②	Rod seal	NBR	
③	Back-up ring	Resin	
④	Piston seal	NBR	
⑤	Cylinder tube gasket	NBR	
⑥	Holder gasket	NBR	
⑦	Valve seal	NBR	
⑧	Valve holder gasket	NBR	
⑨	Cushion seal	—	

Replacement Parts: Seal Kit

Bore size (mm)	Seal kit no.	Contents
40	CHSD40-PS	Set of left nos. ①, ②, ③, ④, ⑤, ⑨
50	CHSD50-PS	
63	CHSD63-PS	
80	CHSD80-PS	
100	CHSD100-PS	

* Seal kit consists of items ① to ⑤ and ⑨, and can be ordered by using the seal kit number for each bore size.

ISO Standard Hydraulic Cylinder

Series CHSG

ø32, ø40, ø50
ø63, ø80, ø100

Replacement
Procedure is
P.395

Construction

CH□SGB

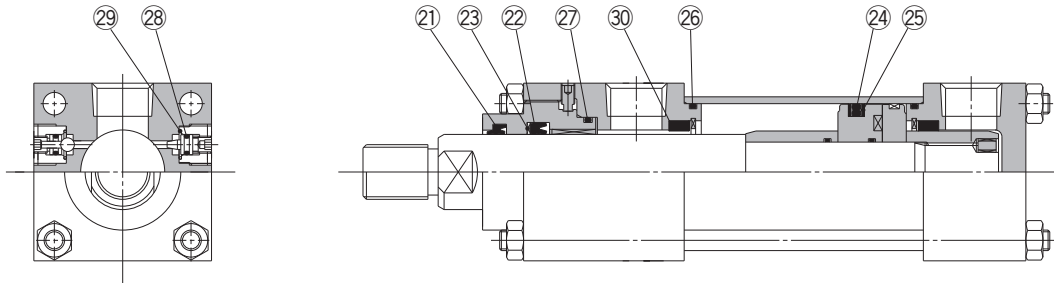

* The numbers are the same as the "Construction" of the Best Pneumatics No.8 Series CHSG.

Seal Kit List

No.	Description	Material	Note
①	Scraper	NBR	27, 28 and 29 are non-replaceable parts, so they are not included in the seal kit.
②	Rod seal	NBR	
③	Back-up ring	Resin	
④	Piston seal	NBR	
⑤	Back-up ring	Resin	
⑥	Cylinder tube gasket	NBR	
⑦	Holder gasket	NBR	
⑧	Valve seal	NBR	
⑨	Valve holder gasket	NBR	
⑩	Cushion seal	—	

Replacement Parts: Seal Kit

Bore size (mm)	Seal kit no.	Contents
32	CHSG32-PS	Set of left nos. ①, ②, ③, ④, ⑤, ⑥, ⑩
40	CHSG40-PS	
50	CHSG50-PS	
63	CHSG63-PS	
80	CHSG80-PS	
100	CHSG100-PS	

* Seal kit consists of items ① to ⑥ and ⑩, and can be ordered by using the seal kit number for each bore size.

Actuators

Modular F.R.L.
Pressure Control Equipment

Air Preparation
Equipment

Industrial Filters

Replacement
Procedure

Actuators

Modular F.R.L.
Pressure Control Equipment

Industrial Filters

JIS Standard Hydraulic Cylinder/Double Acting, Single Rod

Series CH2E/CH2F/CH2G/CH2H

ø32, ø40
ø50, ø63
ø80, ø100

Replacement
Procedure is
P.396

Construction

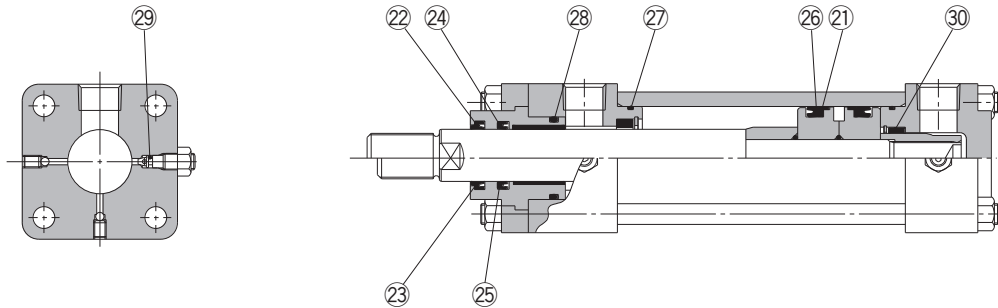

* The numbers are the same as the "Construction" of the Best Pneumatics No.8 Series CH2E/CH2F/CH2G/CH2H.

Seal Kit List

No.	Description	Material	Note
①	Back-up ring	Resin	
②	Scraper (B-series rod)	NBR	
③	Scraper (C-series rod)	NBR	
④	Rod seal (B-series rod)	NBR	
⑤	Rod seal (C-series rod)	NBR	
⑥	Piston seal	NBR	
⑦	Cylinder tube gasket	NBR	
⑧	Holder gasket	NBR	
⑨	Cushion valve seal	NBR	
⑩	Cushion seal	—	

Replacement Parts: Seal Kit

Bore size (mm)	Seal kit no.		Content
	B-series rod	C-series rod	
32	CH2E32B-PS	/	
	CH2F32B-PS		
	CH2G32B-PS		
	CH2H32B-PS		
40	CH2E40B-PS	CH2E40C-PS	
	CH2F40B-PS	CH2F40C-PS	
	CH2G40B-PS	CH2G40C-PS	
	CH2H40B-PS	CH2H40C-PS	
50	CH2E50B-PS	CH2E50C-PS	B-series rod: Set of left nos. ①, ②, ④, ⑥, ⑦, ⑧, ⑨, ⑩
	CH2F50B-PS	CH2F50C-PS	
	CH2G50B-PS	CH2G50C-PS	
	CH2H50B-PS	CH2H50C-PS	
63	CH2E63B-PS	CH2E63C-PS	C-series rod: Set of left nos. ①, ③, ⑤, ⑥, ⑦, ⑧, ⑨, ⑩
	CH2F63B-PS	CH2F63C-PS	
	CH2G63B-PS	CH2G63C-PS	
	CH2H63B-PS	CH2H63C-PS	
80	CH2E80B-PS	CH2E80C-PS	
	CH2F80B-PS	CH2F80C-PS	
	CH2G80B-PS	CH2G80C-PS	
	CH2H80B-PS	CH2H80C-PS	
100	CH2E100B-PS	CH2E100C-PS	
	CH2F100B-PS	CH2F100C-PS	
	CH2G100B-PS	CH2G100C-PS	
	CH2H100B-PS	CH2H100C-PS	

* Seal kit consists of items ① through ⑩ and can be ordered by using the seal kit number for each bore size.

JIS Standard Hydraulic Cylinder/Double Acting, Double Rod

Series CH2EW/CH2FW

ø32, ø40
ø50, ø63
ø80, ø100

Replacement
Procedure is
P.396

Construction

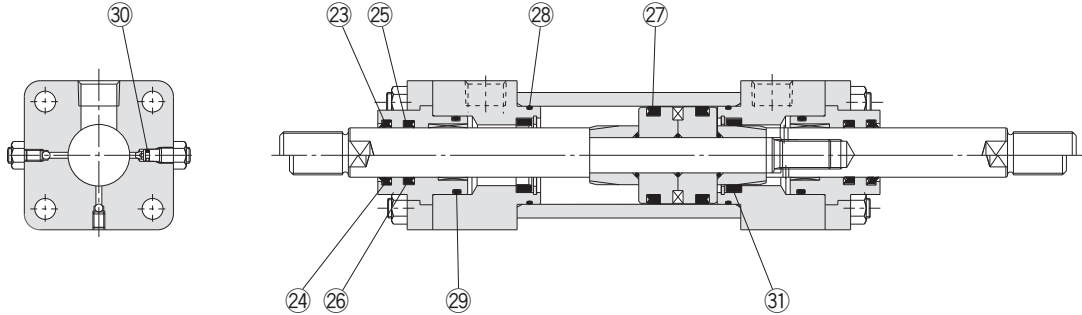

* The numbers are the same as the "Construction" of the Best Pneumatics No.8 Series CH2EW/CH2FW.

Seal Kit List

No.	Description	Material	Note
23	Scraper (B-series rod)	NBR	
24	Scraper (C-series rod)	NBR	
25	Rod seal (B-series rod)	NBR	
26	Rod seal (C-series rod)	NBR	
27	Piston seal	NBR	
28	Cylinder tube gasket	NBR	
29	Holder gasket	NBR	
30	Cushion valve seal	NBR	
31	Cushion seal	—	

Replacement Parts: Seal Kit

Bore size (mm)	Seal kit no.		Content
	B-series rod	C-series rod	
40	CH2EW40B-PS	CH2EW40C-PS	B-series rod: Set of left nos. 23, 25, 27, 28, 29, 30, 31
	CH2FW40B-PS	CH2FW40C-PS	
50	CH2EW50B-PS	CH2EW50C-PS	C-series rod: Set of left nos. 24, 26, 27, 28, 29, 30, 31
	CH2FW50B-PS	CH2FW50C-PS	
63	CH2EW63B-PS	CH2EW63C-PS	
	CH2FW63B-PS	CH2FW63C-PS	
80	CH2EW80B-PS	CH2EW80C-PS	
	CH2FW80B-PS	CH2FW80C-PS	
100	CH2EW100B-PS	CH2EW100C-PS	
	CH2FW100B-PS	CH2FW100C-PS	

* Seal kit consists of items 23 through 31 and can be ordered using the seal kit number for each bore size.

Actuators

Modular F.R.L.
Pressure Control Equipment

Air Preparation
Equipment

Industrial Filters

Replacement
Procedure

Actuators

Modular F.R.L.
Pressure Control Equipment

Industrial Filters

Tie-rod Type Hydraulic Cylinder/Double Acting, Single Rod

Series CHA

ø40, ø50, ø63, ø80
ø100, ø125, ø160

Construction

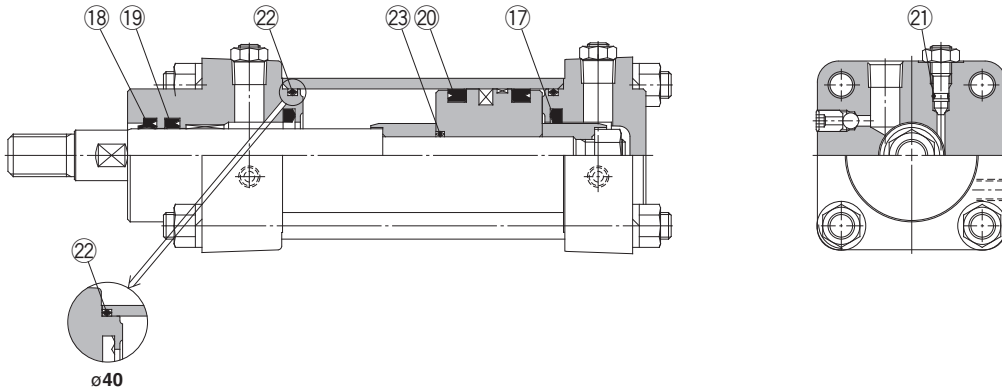

* The numbers are the same as the "Construction" of the Best Pneumatics No.8 Series CHA.

Seal Kit List

No.	Description	Material	Note
⑰	Cushion seal	—	23 is a non-replaceable part, so it is not included in the seal kit.
⑱	Wiper ring	NBR	
⑲	Rod seal	NBR	
⑳	Piston seal	NBR	
㉑	Needle valve seal	NBR	
㉒	Cylinder tube gasket	NBR	
㉓	Piston gasket	NBR	

Replacement Parts: Seal Kit

Bore size (mm)	Seal kit no.	Content
40	CHA40-PS	Set of left nos. ⑰, ⑱, ⑲, ⑳, ㉑, ㉒
50	CHA50-PS	
63	CHA63-PS	
80	CHA80-PS	
100	CHA100-PS	
125	CHA125-PS	
160	CHA160-PS	

* Seal kit consists of items ⑰ through ㉒ and can be ordered using the seal kit number for each bore size.

Tie-rod Nut Tightening Torque

Bore size (mm)	Tightening torque(N·m)
40	10.8 ± 1.1
50	24.5 ± 2.4
63	24.5 ± 2.4
80	38.2 ± 3.8
100	38.2 ± 3.8
125	68.6 ± 6.8
160	107.8 ± 10.7

* Gradually tighten the tie-rod nuts equally from opposing corners so that the tightening torques become the same as those listed above.

Series CHAW

ø40, ø50, ø63, ø80
ø100, ø125, ø160

Construction

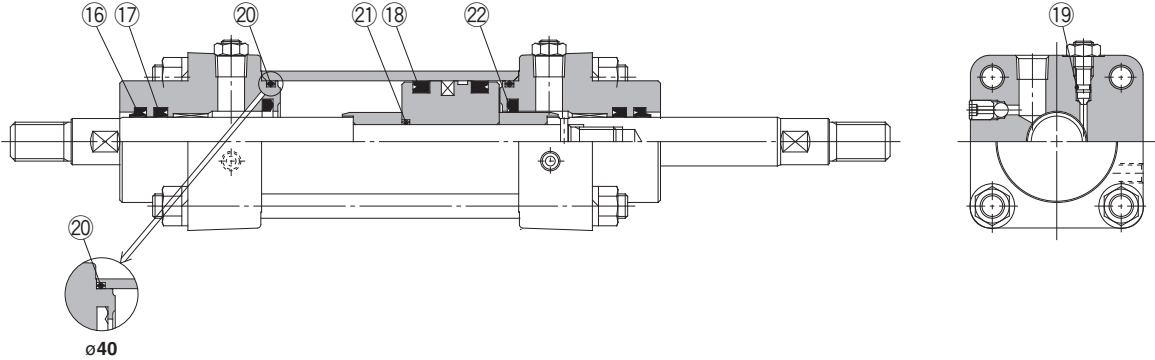

* The numbers are the same as the "Construction" of the Best Pneumatics No.8 Series CHAW.

Seal Kit List

No.	Description	Material	Note
16	Wiper ring	NBR	21 is a non-replaceable part, so it is not included in the seal kit.
17	Rod seal	NBR	
18	Piston seal	NBR	
19	Needle valve seal	NBR	
20	Cylinder tube gasket	NBR	
21	Piston gasket	NBR	
22	Cushion seal	—	

Replacement Parts: Seal Kit

Bore size (mm)	Seal kit no.	Content
40	CHAW40-PS	Set of left nos. 16, 17, 18, 19, 20, 22
50	CHAW50-PS	
63	CHAW63-PS	
80	CHAW80-PS	
100	CHAW100-PS	
125	CHAW125-PS	
160	CHAW160-PS	

* Seal kit consists of items of 16 through 20 and 22 and can be ordered by using the seal kit number for each bore size.

Tie-rod Nut Tightening Torque

Bore size (mm)	Tightening torque(N·m)
40	10.8 ± 1.1
50	24.5 ± 2.4
63	24.5 ± 2.4
80	38.2 ± 3.8
100	38.2 ± 3.8
125	68.6 ± 6.8
160	107.8 ± 10.7

* Gradually tighten the tie-rod nuts equally from opposing corners so that the tightening torques become the same as those listed above.

Made to Order Common Specifications (-XB□, -XC□)

Series **MGP-□Z**

Replacement Parts: Seal Kit

* Seal kit part numbers other than below are the same as basic type.

* Since the seal kit does not include a grease pack, order it separately. For details, refer to page 125.

Bore size (mm)	MGP□R(NBR)/MGP□V(FKM) (Water resistant)		XB6 (Heat resistant cylinder -10 to 150°C)	XB13 (Low speed cylinder 5 to 50 mm/s)
12	—	—	MGP12-Z-XB6-PS	MGP12-Z-XB13-PS
16	—	—	MGP16-Z-XB6-PS	MGP16-Z-XB13-PS
20	MGP20R-Z-PS	MGP20V-Z-PS	MGP20-Z-XB6-PS	MGP20-Z-XB13-PS
25	MGP25R-Z-PS	MGP25V-Z-PS	MGP25-Z-XB6-PS	MGP25-Z-XB13-PS
32	MGP32R-Z-PS	MGP32V-Z-PS	MGP32-Z-XB6-PS	MGP32-Z-XB13-PS
40	MGP40R-Z-PS	MGP40V-Z-PS	MGP40-Z-XB6-PS	MGP40-Z-XB13-PS
50	MGP50R-Z-PS	MGP50V-Z-PS	MGP50-Z-XB6-PS	MGP50-Z-XB13-PS
63	MGP63R-Z-PS	MGP63V-Z-PS	MGP63-Z-XB6-PS	MGP63-Z-XB13-PS
80	MGP80R-Z-PS	MGP80V-Z-PS	MGP80-Z-XB6-PS	MGP80-Z-XB13-PS
100	MGP100R-Z-PS	MGP100V-Z-PS	MGP100-Z-XB6-PS	MGP100-Z-XB13-PS

Bore size (mm)	XC4 (With heavy duty scraper)	XC6 (Made of stainless steel)	XC8 (Adjustable stroke cylinder/Adjustable extension type)
12	—	MGP12-Z-PS	MGP12-Z-XC8-PS
16	—	MGP16-Z-PS	MGP16-Z-XC8-PS
20	MGP20-Z-PS	MGP20-Z-PS	MGP20-Z-XC8-PS
25	MGP25-Z-PS	MGP25-Z-PS	MGP25-Z-XC8-PS
32	MGP32-Z-PS	MGP32-Z-PS	MGP32-Z-XC8-PS
40	MGP40-Z-PS	MGP40-Z-PS	MGP40-Z-XC8-PS
50	MGP50-Z-XC4-PS	MGP50-Z-XC6-PS	MGP50-Z-XC8-PS
63	MGP63-Z-XC4-PS	MGP63-Z-XC6-PS	MGP63-Z-XC8-PS
80	MGP80-Z-XC4-PS	MGP80-Z-XC6-PS	MGP80-Z-XC8-PS
100	MGP100-Z-XC4-PS	MGP100-Z-XC6-PS	MGP100-Z-XC8-PS

Bore size (mm)	XC9 (Adjustable stroke cylinder/Adjustable retraction type)	XC22 (Fluororubber seal)	XC35 (With coil scraper)
12	MGP12-Z-XC9-PS	MGP12-Z-XC22-PS	—
16	MGP16-Z-XC9-PS	MGP16-Z-XC22-PS	—
20	MGP20-Z-XC9-PS	MGP20-Z-XC22-PS	MGP20-Z-PS
25	MGP25-Z-XC9-PS	MGP25-Z-XC22-PS	MGP25-Z-PS
32	MGP32-Z-XC9-PS	MGP32-Z-XC22-PS	MGP32-Z-PS
40	MGP40-Z-XC9-PS	MGP40-Z-XC22-PS	MGP40-Z-PS
50	MGP50-Z-XC9-PS	MGP50-Z-XC22-PS	MGP50-Z-XC35-PS
63	MGP63-Z-XC9-PS	MGP63-Z-XC22-PS	MGP63-Z-XC35-PS
80	MGP80-Z-XC9-PS	MGP80-Z-XC22-PS	MGP80-Z-XC35-PS
100	MGP100-Z-XC9-PS	MGP100-Z-XC22-PS	MGP100-Z-XC35-PS

Grease Pack Part No.

* Grease pack part numbers other than below are the same as basic type.

Symbol	Specifications	Grease pack part no.
25A-	Copper and Zinc-free	GR-D-010 (10 g)
XB6	Heat resistant cylinder (-10 to 150°C)	GR-F-005 (5 g)
XB13	Low speed cylinder (5 to 50 mm/s)	GR-L-010 (10 g)
XC85	Grease for food processing equipment	GR-H-010 (10 g)

Series MGP

Replacement Parts: Seal Kit

* Seal kit part numbers other than below are the same as basic type.

* Since the seal kit does not include a grease pack, order it separately. For details, refer to page 126.

Bore size (mm)	MGP□R(NBR)/MGP□V(FKM) (Water resistant)		XB6 (Heat resistant cylinder -10 to 150°C)	XB9 (Low speed cylinder 10 to 50 mm/s)
12	—	—	MGP12-XB6-PS	MGP12-XB9-PS
16	—	—	MGP16-XB6-PS	MGP16-XB9-PS
20	MGP20R-PS	MGP20V-PS	MGP20-XB6-PS	MGP20-XB9-PS
25	MGP25R-PS	MGP25V-PS	MGP25-XB6-PS	MGP25-XB9-PS
32	MGP32R-PS	MGP32V-PS	MGP32-XB6-PS	MGP32-XB9-PS
40	MGP40R-PS	MGP40V-PS	MGP40-XB6-PS	MGP40-XB9-PS
50	MGP50R-PS	MGP50V-PS	MGP50-XB6-PS	MGP50-XB9-PS
63	MGP63R-PS	MGP63V-PS	MGP63-XB6-PS	MGP63-XB9-PS
80	MGP80R-PS	MGP80V-PS	MGP80-XB6-PS	MGP80-XB9-PS
100	MGP100R-PS	MGP100V-PS	MGP100-XB6-PS	MGP100-XB9-PS

Bore size (mm)	XB13 (Low speed cylinder 5 to 50 mm/s)	XC8 (Adjustable stroke cylinder/Adjustable extension type)	XC9 (Adjustable stroke cylinder/Adjustable retraction type)
12	MGP12-XB13-PS	MGP12-XC8-PS	MGP12-XC9-PS
16	MGP16-XB13-PS	MGP16-XC8-PS	MGP16-XC9-PS
20	MGP20-XB13-PS	MGP20-XC8-PS	MGP20-XC9-PS
25	MGP25-XB13-PS	MGP25-XC8-PS	MGP25-XC9-PS
32	MGP32-XB13-PS	MGP32-XC8-PS	MGP32-XC9-PS
40	MGP40-XB13-PS	MGP40-XC8-PS	MGP40-XC9-PS
50	MGP50-XB13-PS	MGP50-XC8-PS	MGP50-XC9-PS
63	MGP63-XB13-PS	MGP63-XC8-PS	MGP63-XC9-PS
80	MGP80-XB13-PS	MGP80-XC8-PS	MGP80-XC9-PS
100	MGP100-XB13-PS	MGP100-XC8-PS	MGP100-XC9-PS

Bore size (mm)	XC22 (Fluororubber seal)
12	MGP12-XC22-PS
16	MGP16-XC22-PS
20	MGP20-XC22-PS
25	MGP25-XC22-PS
32	MGP32-XC22-PS
40	MGP40-XC22-PS
50	MGP50-XC22-PS
63	MGP63-XC22-PS
80	MGP80-XC22-PS
100	MGP100-XC22-PS

Grease Pack Part No.

* Grease pack part numbers other than below are the same as basic type.

Symbol	Specifications	Grease pack part no.
25A-	Copper and Zinc-free	GR-D-010 (10 g)
XB6	Heat resistant cylinder (-10 to 150°C)	GR-F-005 (5 g)
XB9	Low speed cylinder (10 to 50 mm/s)	GR-F-005 (5 g)
XB13	Low speed cylinder (5 to 50 mm/s)	GR-L-010 (10 g)
XC85	Grease for food processing equipment	GR-H-010 (10 g)

Actuators

Modular F.R.L.
Pressure Control Equipment

Air Preparation
Equipment

Industrial Filters

Replacement
Procedure

Actuators

Modular F.R.L.
Pressure Control Equipment

Industrial Filters

Modular F.R.L. Pressure Control Equipment

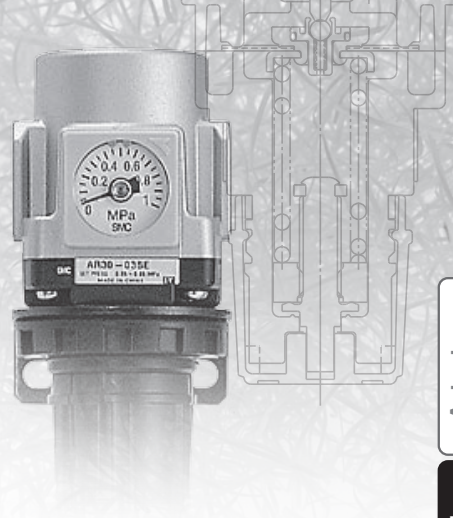
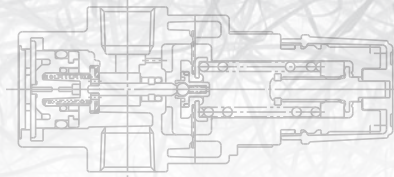

- 1** Indication of replacement of elements, inspection items P.216
- 2** Troubleshooting P.217
- 3** Details of replacement parts

AF10 to AF60	Air Filter	P.220
AFM20 to AFM40	Mist Separator	P.221
AFD20 to AFD40	Micro Mist Separator	P.221
AR10 to AR60	Regulator	P.222
AR20K to AR60K	Regulator with Backflow Function	P.222
AL10 to AL60	Lubricator	P.223
AW10 to AW60	Filter Regulators	P.224
AW20K to AW60K	Filter Regulator with Backflow Function	P.224
AWM20 to AWM40	Mist Separator Regulator	P.225
AWD20 to AWD40	Micro Mist Separator Regulator	P.225
AC, ACG	Air Combination	P.226
ARG20(K)/30(K)/40(K)	Regulator with Built-in Pressure Gauge	P.228
AWG20/30/40	Filter Regulator with Built-in Pressure Gauge	P.229
AWG20K/30K/40K	Filter Regulator with Built-in Pressure Gauge with Backflow Function	P.230
AR425 to 935	Pilot Operated Regulator	P.231
AMR3000 to 6000	MR Unit (Regulator with Mist Separator)	P.232
ARM5A	Compact Manifold Regulator/Centralized Supply Type	P.233
ARM5B	Compact Manifold Regulator/Individual Supply Type	P.234
ARM5S	Regulator/Single Unit Type	P.235
ARM10	Regulator/Single Unit Type	P.236
ARM11A	Compact Manifold Regulator/Common Supply Type	P.237
ARM11B	Compact Manifold Regulator/Individual Supply Type	P.238
ARM11A/B	Compact Manifold Regulator/Options	P.239

Actuators

Modular F.R.L.
Pressure Control Equipment

Air Preparation
Equipment

Industrial Filters

Replacement
Procedure

Actuators

Modular F.R.L.
Pressure Control Equipment

Industrial Filters

Modular F.R.L. Pressure Control Equipment

1 Indication of replacement of elements, inspection items

The following describes the general contents of the element replacement and regular check.

Indication of replacement of air filter, inspection items

■ Replacement standards

<Element replacement>

The differential pressure (pressure drop) between the primary side and secondary side reaches 0.1 MPa. Even when any pressure differential does not occur, replace the element every two years.

■ Inspection items

1) Checking of external leak or case crack.

If the case is cracked, this may lead to a serious accident, such as case rupture. So, replace the case immediately and locate the cause. If the case is contaminated significantly and the internal status cannot be checked, clean the case with neutral detergent. At this time, never use solvent or machine cleaning solution.

2) Functional inspection of drain discharge mechanism

Check that the drain mechanism functions correctly without fail and that the drain is discharged periodically for manual type.

If the drain is produced excessively, a trouble may occur in the purification equipment on the upstream side.

■ Probable troubles (Reference)

Refer to the "Troubleshooting" for air filter/auto drain. (P.217)

Regulator inspection items

■ Inspection items

Check the set pressure level before starting up the equipment. If the set pressure level is beyond the specified range, locate the cause.

(Be sure to locate the cause before starting the readjustment.) Additionally, check the following points during periodic inspection.

1) Functional inspection and grease-up of the valve body (including the valve guide)

2) Functional inspection and grease-up of the valve spring

Check for rust, breakage, or permanent settling.

3) Checking of setting function and relief function (Check the functions by increasing or decreasing the setting.)

■ Probable troubles (Reference)

Refer to the "Troubleshooting" for regulator. (P.218)

Lubricator inspection items

■ Inspection items

① Inspection of dripping volume: Inspect this item when starting the equipment operation.

② Check the oil status inside the case. Check for drain entry.

③ Check for air leak inside the case or air backflow on the secondary side.

■ Probable troubles (Reference)

Refer to the "Troubleshooting" for lubricator. (P.219)

2 Troubleshooting

The following describes the general contents of the troubleshooting.

[Air filter/Auto drain]

Trouble (Symptom)	Cause	Corrective action
The pressure drop is large and the specified flow rate cannot be obtained.	1. The element is clogged.	1. Replace the element.
The air leaks from the portion between the bowl and body.	1. The bowl O-ring is damaged.	1. Replace the bowl O-ring. Apply the grease to the bowl O-ring, and then assemble it into the bowl.
The air leaks from the bowl.	1. The bowl is damaged.	1. Replace the bowl assembly or replace the bowl with a metallic bowl.
The air leaks from the drain cock.	1. A foreign object is caught in the valve of the drain cock.	1. Open the drain cock for several seconds to blow out the foreign object.
	2. The drain cock seat is damaged.	2. Replace the bowl assembly.
The drain is not discharged even when the drain cock is opened.	1. The discharge port of the drain cock is clogged with solid foreign object.	1. Replace the bowl assembly.
An excessive amount of drain is discharged to the pipe at the outlet.	1. The drain level exceeds the baffle.	1. Open the drain cock to discharge the drain, and then replace the element.

Modular F.R.L. Pressure Control Equipment

2 Troubleshooting

The following describes the general contents of the troubleshooting.

[Regulator]

Trouble (Symptom)	Cause	Corrective action
The pressure cannot be regulated.	1. The regulator is installed in a direction opposite to the flow direction.	1. Check the flow direction. If the installation direction is opposite to the flow direction, reinstall the regulator.
	2. The spring is broken.	2. Replace the spring.
	3. The valve spring is broken.	3. Replace the valve spring.
	4. A foreign object is caught in the valve seat or valve O-ring.	4. Remove the valve guide, and then clean the valve, valve seat, and valve O-ring. At this time, apply the grease to the valve O-ring and sliding part after cleaning.
	5. The rubber lining surface of the valve is damaged.	5. Replace the valve.
	6. A foreign object is caught in the check valve seat. (AR20K to AR60K)	6. Replace the check valve assembly.
The set pressure level does not become zero (0) even when the handle is loosened.	1. A foreign object is caught in the valve seat or valve O-ring.	1. Remove the valve guide, and then clean the valve, valve seat, and valve O-ring. At this time, apply the grease to the valve O-ring and sliding part after cleaning.
	2. The rubber seat surface of the valve is damaged.	2. Replace the valve.
	3. The valve spring is broken.	3. Replace the valve spring.
	4. The valve is locked.	4. Clean the sliding surface of the valve O-ring and apply the grease.
	5. A foreign object is caught in the check valve seat. (AR20K to AR60K)	5. Replace the check valve assembly.
The air leaks from the exhaust port in the bonnet.	1. The diaphragm is damaged.	1. Replace the diaphragm assembly.
	2. The piston seal is damaged.	2. Replace the piston assembly or clean it. At this time, apply the grease to the piston seal and sliding surface.
	3. A foreign object is caught in the exhaust valve seat.	3. Clean the exhaust valve seat or replace the diaphragm assembly.
	4. A foreign object is caught in the valve seat or valve O-ring.	4. Remove the valve guide, and then clean the valve, valve seat, and valve O-ring. At this time, apply the grease to the valve O-ring and sliding part after cleaning.
	5. The rubber sheet surface of the valve is damaged.	5. Replace the valve.
	6. The back pressure exceeding the set pressure level is applied to the secondary side.	6. Review the air circuit so that the back pressure exceeding the set pressure level is not applied.
	7. A foreign object is caught in the check valve seat. (AR20K to AR60K)	7. Replace the check valve assembly.

[Regulator]

Trouble (Symptom)	Cause	Corrective action
The air leaks from the portion between the bonnet and body.	1. The bonnet screw is loose.	1. Retighten the bonnet screw.
	2. The diaphragm is damaged.	2. Replace the diaphragm assembly.
The air does not flow backward.	1. A foreign object is caught in the sliding part of the check valve, causing malfunction. (AR20K to AR60K)	1. Replace the check valve assembly.
	2. The check valve is locked. (AR20K to AR60K)	2. Replace the check valve assembly.

[Lubricator]

Trouble (Symptom)	Cause	Corrective action
The oil does not drop even when the air flows.	1. The equipment is not connected correctly.	1. Check the "IN", "OUT", and arrow marks on the equipment. If any incorrect connection is found, connect the equipment again.
	2. The oil volume inside the bowl is insufficient.	2. Supply the oil.
	3. The air consumption flow rate is insufficient.	3. Select an appropriate lubricator with a minimum dripping flow rate suitable for the flow rate to be used.
	4. The damper is damaged.	4. Replace the damper (assembly).
	5. The oil adjustment valve is closed.	5. Open the oil adjustment valve.
	6. The air leaks from the bowl or lubrication plug.	6. Replace the case O-ring or lubrication plug assembly.
	7. The element is clogged.	7. Replace the damper pushing air assembly.
	8. The air leaks from the sight dome.	8. Replace the sight dome assembly.
Air bubbles are mixed in the oil drop.	1. The oil passage pipe seal is damaged.	1. Replace the damper retainer air assembly.
	2. The oil volume inside the bowl is insufficient.	2. Supply the oil.
The air or oil leaks from the sight glass.	1. The sight dome is damaged.	1. Replace the sight dome assembly.
	2. The O-ring is damaged.	2. Replace the sight dome assembly.
The air leaks from the lubrication plug.	1. The O-ring is damaged.	1. Replace the lubrication plug assembly.
The air leaks from the portion between the bowl and body.	1. The bowl O-ring is damaged.	1. Replace the bowl O-ring. Apply the grease to the bowl O-ring and assemble it into the bowl.
The air leaks from the bowl	1. The bowl is damaged.	1. Replace the bowl assembly or replace the bowl with a metallic bowl.

AF10 to AF60



Construction

AF10, AF20

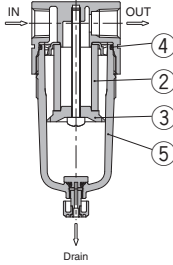

AF30 to AF40-06

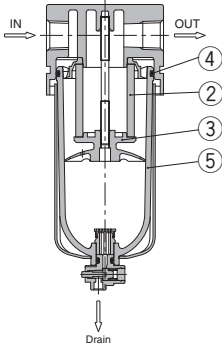

AF50, AF60

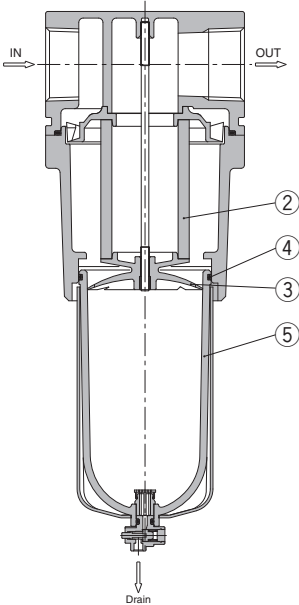

Replacement Parts

No.	Description	Material	Part no.					
			AF10	AF20	AF30	AF40	AF40-06	AF50
②	Filter element	Non-woven fabric	AF10P-060S	AF20P-060S	AF30P-060S	AF40P-060S	AF50P-060S	AF60P-060S
③	Baffle	PBT	AF10P-040S ^{Note 1)}	AF20P-040S	AF30P-040S	AF40P-040S	AF50P-040S	AF60P-040S
④	Bowl O-ring	NBR	C1SFP-260S	C2SFP-260S	C3SFP-260S	C4SFP-260S		
⑤	Bowl assembly ^{Note 2)}	Polycarbonate	C1SF	C2SF	C3SF ^{Note 3)}	C4SF ^{Note 3)}		

Note 1) The material of the baffle for the AF10 (AF10P-040S) only is polyacetal.

Note 2) Bowl O-ring is included.

Please contact SMC regarding the bowl assembly supply for psi and °F unit specifications.

Note 3) Bowl assembly for the AF30 to AF60 models comes with a bowl guard (steel band material).

Options/Part No.

Optional specifications	Model						
	AF10	AF20	AF30	AF40	AF40-06	AF50	AF60
Bracket assembly ^{Note 1)}	—	AF20P-050AS	AF30P-050AS	AF40P-050AS	AF40P-070AS	AF50P-050AS	AF50P-050AS
Float type auto drain ^{Note 2) Note 3)}	N.C.	AD17	AD27	AD37	AD47		
	N.O.	—	—	AD38	AD48		

Semi-standard/Bowl Assembly Part No.

Bowl material	Semi-standard specifications				Model						
	Note 2) Note 3) Float type auto drain	Note 3) With drain guide	With barb fitting	With bowl guard	AF10	AF20	AF30	AF40	AF40-06	AF50	AF60
Polycarbonate	—	—	—	●	—	C2SF-C	—	—	—	—	—
	●	—	—	—	—	AD27-C	—	—	—	—	—
	—	—	●	—	—	C2SF-J	C3SF-J	—	C4SF-J	—	—
	—	—	—	●	—	—	C3SF-W	—	C4SF-W	—	—
Nylon	—	—	●	—	—	C2SF-CJ	—	—	—	—	—
	—	—	—	—	—	C1SF-6	C2SF-6	C3SF-6	—	C4SF-6	—
	—	—	—	—	—	—	C2SF-6C	—	—	—	—
	●	—	—	—	—	AD17-6	AD27-6	AD37-6	—	AD47-6	—
	—	●	—	—	—	—	AD38-6	—	—	AD48-6	—
	●	—	—	—	—	—	AD27-6C	—	—	—	—
Metal	—	—	—	—	—	C2SF-6J	C3SF-6J	—	C4SF-6J	—	—
	—	—	●	—	—	—	C3SF-6W	—	C4SF-6W	—	—
	—	—	—	—	—	—	C2SF-6CJ	—	—	—	—
	—	—	—	—	—	C1SF-2	C2SF-2	C3SF-2	—	C4SF-2	—
Metal bowl with level gauge	●	—	—	—	—	AD17-2	AD27-2	AD37-2	—	AD47-2	—
	—	—	—	—	—	—	AD38-2	—	—	AD48-2	—
	—	—	●	—	—	—	C2SF-2J	C3SF-2J	—	C4SF-2J	—
	—	—	—	—	—	—	C3LF-8	—	—	C4LF-8	—
Metal bowl with level gauge	●	—	—	—	—	—	AD37-8	—	—	AD47-8	—
	—	●	—	—	—	—	AD38-8	—	—	AD48-8	—
	—	—	●	—	—	—	C3LF-8J	—	—	C4LF-8J	—

Note 1) Assembly of a bracket and 2 mounting screws

Note 2) Minimum operating pressure: N.O. type—0.1 MPa; N.C. type—0.1 MPa (AD17/27) and 0.15 MPa (AD37/47). Please contact SMC for psi and °F unit specifications.

Note 3) Please consult with SMC for details on drain piping to fit NPT or G port sizes.

Note) • Bowl O-ring is included for the AF20 to AF60.

• Bowl assembly for the AF30 to AF60 models comes with a bowl guard (steel band material). (except when the bowl material is metal)

Mist Separator / Micro Mist Separator

AFM20 to AFM40 / AFD20 to AFD40

Replacement Procedure is P. 402

Construction

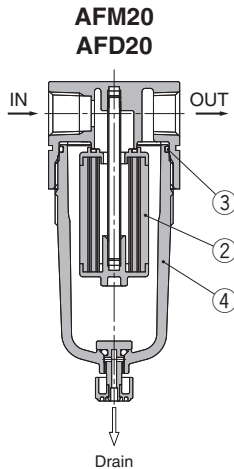

AFM20 to AFM40-06
AFD20 to AFD40-06

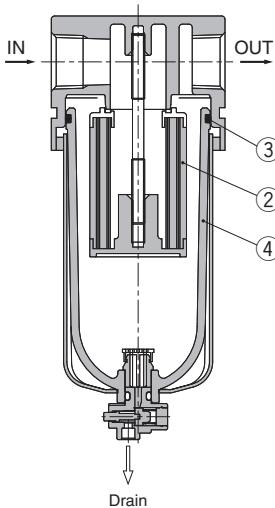

Replacement Parts

No.	Description	Material	Part no.			
			AFM20 AFD20	AFM30 AFD30	AFM40 AFD40	AFM40-06 AFD40-06
②	Element assembly	AFM20 to 40 AFD20 to 40	— —	AFM20P-060AS AFD20P-060AS	AFM30P-060AS AFD30P-060AS	AFM40P-060AS AFD40P-060AS
③	Bowl O-ring	NBR	C2SFP-260S	C3SFP-260S	C4SFP-260S	
④	Bowl assembly ^{Note 1)}	Polycarbonate	C2SF	C3SF ^{Note 2)}	C4SF ^{Note 2)}	

Note 1) Bowl O-ring is included.

Please contact SMC regarding the bowl assembly supply for psi and °F unit specifications.

Note 2) Bowl assembly for the AFM30 to AFM40-06 models and the AFD30 to AFD40-06 models comes with a bowl guard (steel band material).

Options/Part No.

Optional specifications	Model			
	AFM20 AFD20	AFM30 AFD30	AFM40 AFD40	AFM40-06 AFD40-06
Bracket assembly ^{Note 1)}	AF20P-050AS	AF30P-050AS	AF40P-050AS	AF40P-070AS
Float type auto drain ^{Note 2) Note 3)}	N.C.	AD27	AD37	AD47
	N.O.	—	AD38	AD48

Semi-standard/Bowl Assembly Part No.

Semi-standard specifications						Model			
Bowl material	^{Note 2) Note 3)} Float type auto drain	^{Note 3)} With drain guide	^{Note 3)} With barb fitting	^{Note 3)} With bowl guard		AFM20 AFD20	AFM30 AFD30	AFM40 AFD40	AFM40-06 AFD40-06
	N.C.	N.O.	—	●		—	—	—	—
Polycarbonate	—	—	—	●	C2SF-C	—	—	—	—
	●	—	—	●	AD27-C	—	—	—	—
	—	—	●	—	C2SF-J	C3SF-J	—	C4SF-J	—
	—	—	—	●	—	C3SF-W	—	C4SF-W	—
Nylon	—	—	●	●	C2SF-CJ	—	—	—	—
	—	—	—	—	C2SF-6	C3SF-6	—	C4SF-6	—
	—	—	—	●	C2SF-6C	—	—	—	—
	●	—	—	—	AD27-6	AD37-6	—	AD47-6	—
Metal	—	—	—	—	—	AD38-6	—	AD48-6	—
	—	—	●	—	C2SF-6J	C3SF-6J	—	C4SF-6J	—
	—	—	—	●	—	C3SF-6W	—	C4SF-6W	—
	—	—	●	—	C2SF-6CJ	—	—	—	—
Metal bowl with level gauge	—	—	—	—	C2SF-2	C3SF-2	—	C4SF-2	—
	●	—	—	—	AD27-2	AD37-2	—	AD47-2	—
	—	—	—	—	—	AD38-2	—	AD48-2	—
	—	—	●	—	C2SF-2J	C3SF-2J	—	C4SF-2J	—
Metal bowl with level gauge	—	—	—	—	—	C3LF-8	—	C4LF-8	—
	●	—	—	—	—	AD37-8	—	AD47-8	—
	—	—	—	—	—	AD38-8	—	AD48-8	—
Metal bowl with level gauge	—	—	●	—	—	C3LF-8J	—	C4LF-8J	—
	—	—	—	—	—	—	—	—	—

Note 1) Assembly of a bracket and 2 mounting screws

Note 2) Minimum operating pressure: N.O. type—0.1 MPa; N.C. type—0.1 MPa (AD27) and 0.15 MPa (AD37/47). Please consult with SMC separately for psi and °F unit display specifications.

Note 3) Please consult with SMC for details on drain piping to fit NPT or G port sizes.

Note) • Bowl O-ring is included.

• Bowl assembly for the AFM30 to AFM40-06 models and AFD30 to AFD40-06 models comes with a bowl guard (steel band material). (except when the bowl material is metal)

Regulator / Regulator with Backflow Function

AR10 to AR60 / AR20K to AR60K

Replacement
Procedure is
P. 404

Construction

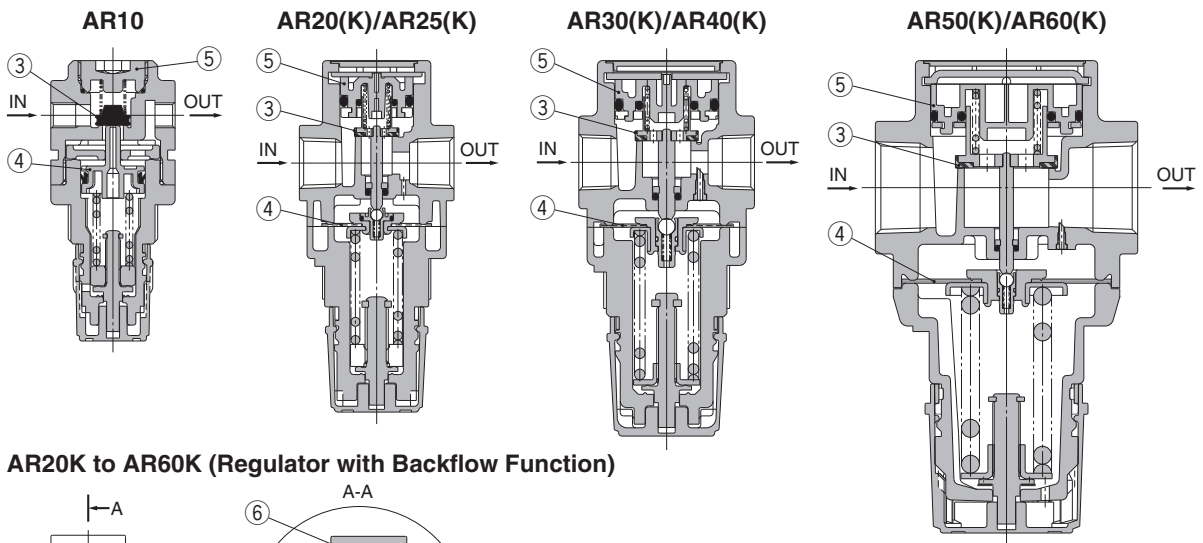

AR20K to AR60K (Regulator with Backflow Function)

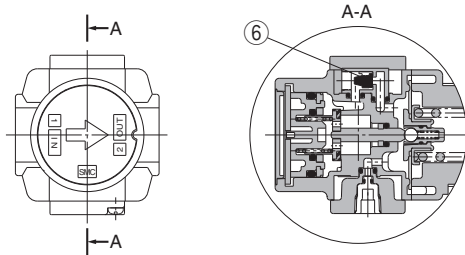

* The numbers are the same as the "Construction" of the Best Pneumatics No.5 Series AR.

Replacement Parts

No.	Description	Material	Part no.							
			AR10	AR20(K)	AR25(K)	AR30(K)	AR40(K)	AR40(K)-06	AR50(K)	AR60(K)
③	Valve assembly	Brass, HNBR	AR10P-090S	AR20P-410S	AR25P-410S	AR30P-410S	AR40P-410S	AR40P-410S	AR50P-410S	AR60P-410S
④	Diaphragm assembly	Weather resistant NBR	AR10P-150AS ^{Note 1)}	AR20P-150AS	AR25P-150AS	AR30P-150AS	AR40P-150AS	AR40P-150AS	AR50P-150AS	AR60P-150AS
⑤	Valve guide assembly	Polycetal	131329	AR20P-050AS	AR25P-050AS	AR30P-050AS	AR40P-050AS	AR40P-050AS	AR50P-050AS	AR60P-050AS
⑥	Check valve assembly ^{Note 2)}	—	—	—	—	—	—	—	—	AR20KP-020AS

Note 1) The AR10 is a piston type. Assembly of a piston and a seal (KSYP-13).

Note 2) Check valve assembly is applicable for a regulator with backflow function (AR20K to AR60K) only.
Assembly of a check valve cover, check valve body assembly and 2 screws

Options/Part No.

Option		Model	AR10	AR20(K)	AR25(K)	AR30(K)	AR40(K)	AR40(K)-06	AR50(K)	AR60(K)
Bracket assembly ^{Note 1)}			AR10P-270AS	AR20P-270AS	AR25P-270AS	AR30P-270AS	AR40P-270AS	AR40P-270AS	AR50P-270AS ^{Note 2)}	AR60P-270AS ^{Note 2)}
Set nut			AR10P-260S	AR20P-260S	AR25P-260S	AR30P-260S	AR40P-260S	AR40P-260S	— ^{Note 3)}	— ^{Note 3)}
Pressure gauge	Round type ^{Note 4)}	Standard	G27-10-R1		G36-10-□01				G46-10-□02	
		0.02 to 0.2 MPa setting	G27-10-R1 ^{Note 5)}		G36-2-□01				G46-2-□02	
	Round type (with color zone) ^{Note 4)}	Standard	—		G36-10-□01-L				G46-10-□02-L	
		0.02 to 0.2 MPa setting	—		G36-2-□01-L				G46-2-□02-L	
Square embedded type ^{Note 6)}	Standard	—			GC3-10AS [GC3P-010AS (Pressure gauge cover only)]					
	0.02 to 0.2 MPa setting	—			GC3-2AS [GC3P-010AS (Pressure gauge cover only)]					
Digital pressure switch	NPN output: Wiring bottom entry	—			ISE35-N-25-MLA [ISE35-N-25-M (Switch body only)] ^{Note 7)}					
	NPN output: Wiring top entry	—			ISE35-R-25-MLA [ISE35-R-25-M (Switch body only)] ^{Note 7)}					
	PNP output: Wiring bottom entry	—			ISE35-N-65-MLA [ISE35-N-65-M (Switch body only)] ^{Note 7)}					
	PNP output: Wiring top entry	—			ISE35-R-65-MLA [ISE35-R-65-M (Switch body only)] ^{Note 7)}					

Note 1) Assembly of a bracket and set nuts

Note 2) Assembly of a bracket and 2 mounting screws

Note 3) Please consult with SMC regarding the set nuts for the AR50(K) and AR60(K).

Note 4) □ in part numbers for a round pressure gauge indicates a type of connection thread. No indication is necessary for R; however, indicate N for NPT.

Please contact SMC regarding the connection thread NPT and pressure gauge supply for psi unit specifications.

Note 5) Pressure gauge for general purpose

Note 6) Including one O-ring and 2 mounting screws. []: Pressure gauge cover only

Note 7) Lead wire with connector (2 m), adapter, lock pin, O-ring (1 pc.), mounting screw (2 pcs.) are attached. []: Switch body only

Also, regarding how to order the digital pressure switch, please refer to the Best Pneumatics No.5.

AL10 to AL60

Replacement Procedure is P.412

Construction

AL10

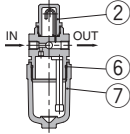

AL20

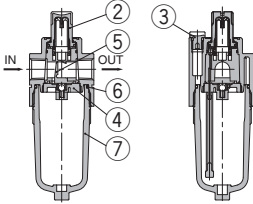

AL30/AL40

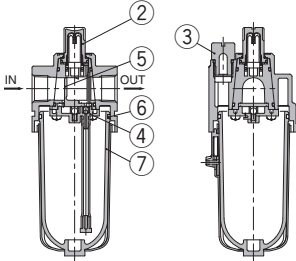

AL50/AL60

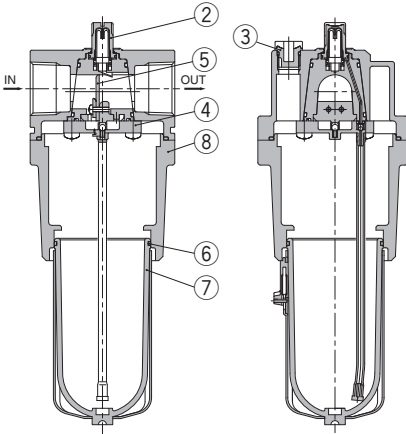

Replacement Parts

No.	Description	Material	Part no.						
			AL10	AL20	AL30	AL40	AL40-06	AL50	AL60
②	Sight dome assembly	Polycarbonate	AL10P-080AS	AL20P-080AS					
③	Lubrication plug assembly	—	—	AL20P-060AS	AL30P-060AS	AL40P-060AS			
④	Damper retainer assembly ^{Note 1)}	—	—	AL20P-030AS	AL30P-030AS	AL40P-030AS	AL50P-030AS	AL60P-030AS	
⑤	Damper (assembly)	Synthetic resin	—	AL20P-040S	AL30P-040S	AL40P-040S	AL50P-040AS	AL60P-040AS	
⑥	Bowl O-ring	NBR	C1SFP-260S	C2SFP-260S	C3SFP-260S	C4SFP-260S			
⑦	Bowl assembly ^{Note 2)}	Polycarbonate	C1SL	C2SL	C3SL ^{Note 3)}	C4SL ^{Note 3)}			

Note 1) Add "–1" at the end of the part number when ordering a damper retainer assembly for 1000 cm³. Example) AL30P-030AS-1

Note 2) Bowl O-ring is included for the AL20 to AL60. Please contact SMC regarding the bowl assembly supply for psi and °F unit specifications.

Note 3) Bowl assembly for the AL30 to AL60 models comes with a bowl guard (steel band material).

Option/Part No.

Optional specifications	Model						
	AL10	AL20	AL30	AL40	AL40-06	AL50	AL60
Bracket assembly ^{Note)}	—	AF20P-050AS	AF30P-050AS	AF40P-050AS	AF40P-070AS	AF50P-050AS	AF50P-050AS

Note) Assembly of a bracket and 2 mounting screws. The part number for bracket assembly for 1000 cm³ is AF50P-050AS (applicable to the AL30 to AL60).

Semi-standard/Bowl Assembly Part No.

Semi-standard specifications						Model						
Bowl material	With drain guide	With barb fitting	With bowl guard	With switch		AL10	AL20	AL30	AL40	AL40-06	AL50	AL60
				Lowest limit ON	Lowest limit OFF							
Polycarbonate	●	—	—	—	—	C1SL-3	C2SL-3	C3SL-3	C4SL-3			
	—	—	●	—	—	—	C2SL-C	—	—	—	—	—
	●	—	●	—	—	—	C2SL-3C	—	—	—	—	—
	●	●	—	—	—	—	—	C3SL-3W	C4SL-3W			
Nylon	—	—	—	—	—	C1SL-6	C2SL-6	C3SL-6	C4SL-6			
	●	—	—	—	—	C1SL-36	C2SL-36	C3SL-36	C4SL-36			
	—	—	●	—	—	—	C2SL-6C	—	—	—	—	—
	●	—	●	—	—	—	C2SL-36C	—	—	—	—	—
Metal	—	—	—	—	—	C1SL-2	C2SL-2	C3SL-2	C4SL-2			
	●	—	—	—	—	C1SL-23	C2SL-23	C3SL-23	C4SL-23			
Metal bowl with level gauge	—	—	—	—	—	—	C3LL-8	C4LL-8				
1000 cm ³ tank (Metal bowl with level gauge)	—	—	—	—	—	—	—	121538-1A				
	—	—	—	●	—	—	—	121538-1A-S1 [IS400-1 (Float switch only)]				
—	—	—	—	●	—	—	—	121538-1A-S2 [IS400-2 (Float switch only)]				

- Note) • Bowl O-ring (or seal) is included for the AL20 to AL60.
 • Bowl assembly for the AL30 to AL60 models comes with a bowl guard (steel band material). (except when the bowl material is metal)
 • Please consult SMC for psi and °F unit display specifications.
 • When switching bowl materials from a polycarbonate or nylon product to a metal bowl with a level gauge, the oil feed tube assembly must be replaced. (Also, when switching bowl materials from a metal bowl with a level gauge to a polycarbonate or nylon product, the oil feed tube assembly must be replaced.) Please consult SMC separately.
 • It is not possible to switch from a polycarbonate, nylon or metal bowl, or from a metal bowl with a level gauge to a 1000 cm³ tank. Please order the product separately.

* The numbers are the same as the "Construction" of the Best Pneumatics No.5 Series AL.

Filter Regulator / Filter Regulator with Backflow Function

AW10 to AW60 / AW20K to AW60K

Replacement
Procedure is
P. 420

Construction

AW10

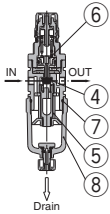

AW20(K)

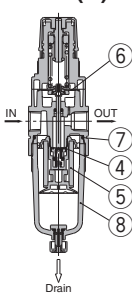

AW30(K)/AW40(K)

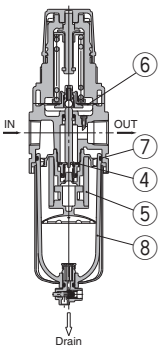

AW60(K)

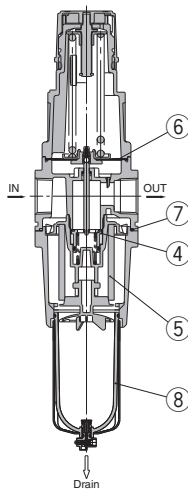

AW20K to AW60K
(Filter Regulator with Backflow Function)

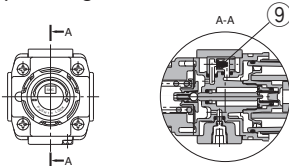

* The numbers are the same as the "Construction" of the Best Pneumatics No.5 Series AW.

Note 1) Assembly of a bracket and set nuts
Note 2) □ in part numbers for a round pressure gauge indicates a type of connection thread. No indication is necessary for R; however, indicate N for NPT. Please contact SMC regarding the connection thread NPT and pressure gauge supply for psi unit specifications.

Note 3) Standard pressure gauge
Note 4) Including one O-ring and 2 mounting screws. []: Pressure gauge cover only

Note 5) Lead wire with connector (2 m), adapter, lock pin, O-ring (1 pc.), mounting screw (2 pcs.) are attached. []: Switch body only. Also, regarding how to order the digital pressure switch, please refer to page 388. A pressure switch adapter assembly (AW60P-310AS) will be additionally required for the AW60(K) only. Use the attached mounting screw (M3 x 0.5 x 14) for mounting. The mounting screw (M3 x 0.5 x 7) attached to the digital pressure switch assembly will not be required.

Replacement Parts

No.	Description	Material	Part no.					
			AW10	AW20(K)	AW30(K)	AW40(K)	AW40(K)-06	AW60(K)
④	Valve assembly	Brass, HNBR	AR10P-090S	AW20P-340AS	AW30P-340AS	AW40P-340AS	AW40P-340AS	AW60P-090AS
⑤	Filter element	Non-woven fabric	AF10P-060S	AF20P-060S	AF30P-060S	AF40P-060S	AF40P-060S	AW60P-060S
⑥	Diaphragm assembly	Weather resistant NBR	AR10P-150AS ^{Note 1)}	AR20P-150AS	AR30P-150AS	AR40P-150AS	AR40P-150AS	AR50P-150AS
⑦	Bowl O-ring	NBR	C1SFP-260S	C2SFP-260S	C3SFP-260S	C4SFP-260S		
⑧	Bowl assembly ^{Note 2)}	Polycarbonate	C1SF	C2SF	C3SF ^{Note 3)}	C4SF ^{Note 3)}		
⑨	Check valve assembly ^{Note 4)}	—	—	AR20KP-020AS				

Note 1) The AW10 is a piston type. Assembly of a piston and a seal (KSYP-13).

Note 2) Bowl O-ring is included for the AW20(K) to AW60(K). Please contact SMC regarding the bowl assembly supply for psi and °F unit specifications.

Note 3) Bowl assembly for the AW30(K) to AW60(K) models comes with a bowl guard (steel band material).

Note 4) Check valve assembly is applicable for a filter regulator with backflow function (AW20K to AW60K) only. Assembly of a check valve cover, check valve body assembly and 2 screws

Options/Part No.

Optional specifications		Model					
		AW10(K)	AW20(K)	AW30(K)	AW40(K)	AW40(K)-06	AW60(K)
Bracket assembly ^{Note 1)}		AR10P-270AS	AW20P-270AS	AR30P-270AS	AR40P-270AS	AW60P-270AS ^{Note 5)}	
Set nut		AR10P-260S	AR20P-260S	AR30P-260S	AR40P-260S	— ^{Note 7)}	
Pressure gauge	Round type ^{Note 2)}	Standard	G27-10-R1	G36-10-□01	G46-10-□02		
		0.02 to 0.2 MPa setting	G27-10-R1 ^{Note 3)}	G36-2-□01	G46-2-□02		
	Round type ^{Note 2)} (with color zone)	Standard	—	G36-10-□01-L	G46-10-□02-L		
		0.02 to 0.2 MPa setting	—	G36-2-□01-L	G46-2-□02-L		
Square embedded type ^{Note 4)}	Standard	—	GC3-10AS [GC3P-010AS (Pressure gauge cover only)]				
	0.02 to 0.2 MPa setting	—	GC3-2AS [GC3P-010AS (Pressure gauge cover only)]				
Digital pressure switch ^{Note 5)}	NPN output/Wiring bottom entry	—	ISE35-N-25-MLA [ISE35-N-25-M (Switch body only)]				
	NPN output/Wiring top entry	—	ISE35-R-25-MLA [ISE35-R-25-M (Switch body only)]				
	PNP output/Wiring bottom entry	—	ISE35-N-65-MLA [ISE35-N-65-M (Switch body only)]				
	PNP output/Wiring top entry	—	ISE35-R-65-MLA [ISE35-R-65-M (Switch body only)]				
Float type auto drain ^{Note 8)} ^{Note 9)}	N.C.	AD17	AD27	AD37	AD47		
	N.O.	—	—	AD38	AD48		

Semi-standard/Bowl Assembly Part No.

Semi-standard specifications					Model					
Bowl material	Note 8) Note 9)	Note 8)	Note 9)	Note 9)	AW10(K)	AW20(K)	AW30(K)	AW40(K)	AW40(K)-06	AW60(K)
	Float type auto drain	With drain guide	With barb fitting	With bowl guard						
Polycarbonate	—	—	—	●	—	C2SF-C	—	—	—	—
	●	—	—	●	—	AD27-C	—	—	—	—
	—	●	—	—	—	C2SF-J	C3SF-J	—	C4SF-J	—
	—	—	●	—	—	—	C3SF-W	—	C4SF-W	—
	—	—	—	●	—	C2SF-CJ	—	—	—	—
	—	—	—	—	●	C1SF-6	C2SF-6	C3SF-6	—	C4SF-6
Nylon	—	—	—	—	—	C2SF-6C	—	—	—	—
	●	—	—	—	AD17-6	AD27-6	AD37-6	—	AD47-6	—
	—	●	—	—	—	—	AD38-6	—	AD48-6	—
	●	—	—	●	—	AD27-6C	—	—	—	—
	—	—	●	—	—	C2SF-6J	C3SF-6J	—	C4SF-6J	—
	—	—	—	●	—	—	C3SF-6W	—	C4SF-6W	—
Metal	—	—	—	—	—	C2SF-6CJ	—	—	—	—
	—	—	—	—	C1SF-2	C2SF-2	C3SF-2	—	C4SF-2	—
	●	—	—	—	AD17-2	AD27-2	AD37-2	—	AD47-2	—
	—	●	—	—	—	—	AD38-2	—	AD48-2	—
Metal bowl with level gauge	—	—	—	—	—	C2SF-2J	C3SF-2J	—	C4SF-2J	—
	—	—	—	—	—	—	C3LF-8	—	C4LF-8	—
	●	—	—	—	—	—	AD37-8	—	AD47-8	—
	—	●	—	—	—	—	AD38-8	—	AD48-8	—
—	—	●	—	—	—	C3LF-8J	—	C4LF-8J	—	

Note 6) Assembly of a bracket and 2 mounting screws

Note 7) Please consult SMC regarding the set nuts for the AW60(K).

Note 8) Minimum operating pressure: N.O. type—0.1 MPa; N.C. type—0.1 MPa (AD27) and 0.15 MPa (AD37/47). Please contact SMC for psi and °F unit specifications.

Note 9) Please consult SMC for details on drain piping to fit NPT or G port sizes.

Note) • Bowl O-ring is included for the AW20(K) to AW60(K).

• Bowl assembly for the AW30(K) to AW60(K) models comes with a bowl guard (steel band material). (except when the bowl material is metal)

Mist Separator Regulator/Micro Mist Separator Regulator

AWM(D)20 to AWM(D)40

Construction

AWM20
AWD20

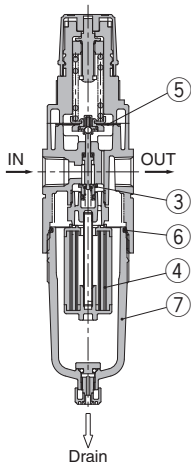

AWM30/40
AWD30/40

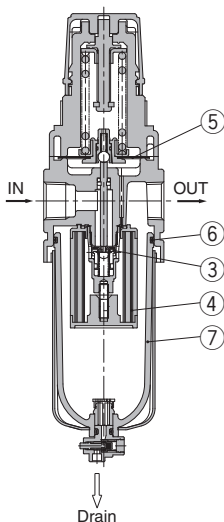

* The numbers are the same as the "Construction" of the Best Pneumatics No.5 Series AWC.

Note 1) Assembly of a bracket and set nuts
 Note 2) □ in part numbers for a round pressure gauge indicates a type of connection thread. No indication is necessary for R; however, indicate N for NPT. Please contact SMC regarding the connection thread NPT and pressure gauge supply for psi unit specifications.

Note 3) Including one O-ring and 2 mounting screws. []: Pressure gauge cover only

Note 4) Lead wire with connector (2 m), adapter, lock pin, O-ring (1 pc.), mounting screw (2 pcs.) are attached. []: Switch body only. Also, regarding how to order the digital pressure switch, please refer to page 388. A separate pressure switch adapter assembly (AW60P-310AS) is required only for AW60(K). For mounting, please use the included mounting screws (M3 x 0.5 x 14). The mounting screw (M3 x 0.5 x 7)

Replacement Parts

No.	Description	Material	Part no.		
			AWM20 AWD20	AWM30 AWD30	AWM40 AWD40
③	Valve assembly	Brass, HNBR	AWM20P-090AS	AWM30P-090AS	AWM40P-090AS
④	Element assembly	AWM20 to AWM40	AFM20P-060AS	AFM30P-060AS	AFM40P-060AS
		AWD20 to AWD40	AFD20P-060AS	AFD30P-060AS	AFD40P-060AS
⑤	Diaphragm assembly	Weather resistant NBR	AR20P-150AS	AR30P-150AS	AR40P-150AS
⑥	Bowl O-ring	NBR	C2SFP-260S	C3SFP-260S	C4SFP-260S
⑦	Bowl assembly ^{Note 1)}	Polycarbonate	C2SF	C3SF ^{Note 2)}	C4SF ^{Note 2)}

Note 1) Bowl O-ring is included. Please contact SMC regarding the bowl assembly supply for psi and "F" unit specifications.

Note 2) Bowl assembly for the AWM30/40, AWD30/40 comes with a bowl guard (steel band material).

Options/Part No.

Optional specifications		Model		
		AWM20 AWD20	AWM30 AWD30	AWM40 AWD40
Bracket assembly ^{Note 1)}		AW20P-270AS	AR30P-270AS	AR40P-270AS
Set nut		AR20P-260S	AR30P-260S	AR40P-260S
Pressure gauge	Round type ^{Note 2)}	Standard	G36-10-□01	G46-10-□02
		0.02 to 0.2 MPa setting	G36-2-□01	G46-2-□02
	Round type ^{Note 2)} (with color zone)	Standard	G36-10-□01-L	G46-10-□02-L
		0.02 to 0.2 MPa setting	G36-2-□01-L	G46-2-□02-L
	Square embedded type ^{Note 3)}	Standard	GC3-10AS [GC3P-010AS (Pressure gauge cover only)]	GC3-2AS [GC3P-010AS (Pressure gauge cover only)]
		0.02 to 0.2 MPa setting	GC3-2AS [GC3P-010AS (Pressure gauge cover only)]	GC3-2AS [GC3P-010AS (Pressure gauge cover only)]
Digital pressure switch ^{Note 4)}	NPN output/Wiring bottom entry	ISE35-N-25-MLA [ISE35-N-25-M (Switch body only)]	ISE35-R-25-MLA [ISE35-R-25-M (Switch body only)]	ISE35-N-65-MLA [ISE35-N-65-M (Switch body only)]
	NPN output/Wiring top entry	ISE35-N-25-MLA [ISE35-N-25-M (Switch body only)]	ISE35-R-25-MLA [ISE35-R-25-M (Switch body only)]	ISE35-N-65-MLA [ISE35-N-65-M (Switch body only)]
	PNP output/Wiring bottom entry	ISE35-N-65-MLA [ISE35-N-65-M (Switch body only)]	ISE35-R-65-MLA [ISE35-R-65-M (Switch body only)]	ISE35-N-65-MLA [ISE35-N-65-M (Switch body only)]
	PNP output/Wiring top entry	ISE35-N-65-MLA [ISE35-N-65-M (Switch body only)]	ISE35-R-65-MLA [ISE35-R-65-M (Switch body only)]	ISE35-N-65-MLA [ISE35-N-65-M (Switch body only)]
Float type auto drain ^{Note 5)} ^{Note 6)}	N.C.	AD27	AD37	AD47
	N.O.	—	AD38	AD48

Semi-standard/Bowl Assembly Part No.

Semi-standard specifications					Model			
Bowl material	Note 5) Note 6)	Note 6)	With drain guide	With barb fitting	With bowl guard	AWM20 AWD20	AWM30 AWD30	AWM40 AWD40
	Float type auto drain	With						
Polycarbonate	—	—	—	—	●	C2SF-C	—	—
	●	—	—	—	●	AD27-C	—	—
	—	—	●	—	—	C2SF-J	C3SF-J	C4SF-J
	—	—	—	●	—	—	C3SF-W	C4SF-W
	—	—	●	—	●	C2SF-CJ	—	—
	—	—	—	—	—	C2SF-6	C3SF-6	C4SF-6
Nylon	—	—	—	—	●	C2SF-6C	—	—
	●	—	—	—	—	AD27-6	AD37-6	AD47-6
	—	●	—	—	—	—	AD38-6	AD48-6
	—	—	—	—	●	AD27-6C	—	—
Metal	—	—	●	—	—	C2SF-6J	C3SF-6J	C4SF-6J
	—	—	—	●	—	—	C3SF-6W	C4SF-6W
	—	—	—	—	●	C2SF-6CJ	—	—
	—	—	—	—	—	C2SF-2	C3SF-2	C4SF-2
Metal bowl with level gauge	●	—	—	—	—	AD27-2	AD37-2	AD47-2
	—	●	—	—	—	—	AD38-2	AD48-2
	—	—	●	—	—	C2SF-2J	C3SF-2J	C4SF-2J
	—	—	—	—	—	—	C3LF-8	C4LF-8
	●	—	—	—	—	—	AD37-8	AD47-8
	—	●	—	—	—	—	AD38-8	AD48-8
	—	—	●	—	—	—	C3LF-8J	C4LF-8J

attached to the digital pressure switch assembly will not be required.

Note 5) Minimum operating pressure: N.O. type=0.1 MPa; N.C. type=0.1 MPa (AD27) and 0.15 MPa (AD37/47). Please contact SMC for psi and "F" unit specifications.

Note 6) Please consult SMC for details on drain piping to fit NPT or G port sizes.

Note 7) Including O-ring.

• Bowl assembly for the AWM30/40, AWD30/40 comes with a bowl guard (steel band material). (except when the bowl material is metal)

Air Combination

Series AC/ACG

Air Filter + Regulator + Lubricator AC10 to 60

Options/Attachments Part No.

Section	Model		Options/Attachments Part No.									
			For AC10	For AC20	For AC25	For AC30	For AC40	For AC40-06	For AC50	For AC55	For AC60	
			For AC10A	For AC20A	—	For AC30A	For AC40A	For AC40A-06	For AC50A	—	For AC60A	
Type		For AC10B	For AC20B	For AC25B	For AC30B	For AC40B	For AC40B-06	For AC50B	For AC55B	For AC60B		
		—	For AC20C	For AC25C	For AC30C	For AC40C	For AC40C-06	—	—	—		
		For AC20D	—	—	For AC30D	For AC40D	For AC40D-06	—	—	—		
Options	Round type type	Standard	G27-10-R1	G36-10-□01			G46-10-□02					
		0.02 to 0.2 MPa setting	G27-10-R1 ^{Note 3)}	G36-2-□01			G46-2-□02					
	Round type (with color zone)	Standard	—	G36-10-□01-L			G46-10-□02-L					
		0.02 to 0.2 MPa setting	—	G36-2-□01-L			G46-2-□02-L					
	Square embedded type	Standard	—	GC3-10AS [GC3P-010AS (Pressure gauge cover only)]								
		0.02 to 0.2 MPa setting	—	GC3-2AS [GC3P-010AS (Pressure gauge cover only)]								
	Digital pressure switch	NPN output/Wiring bottom entry	—	ISE35-N-25-MLA [ISE35-N-25-M (Switch body only)] ^{Note 4)}								
		NPN output/Wiring top entry	—	ISE35-R-25-MLA [ISE35-R-25-M (Switch body only)] ^{Note 4)}								
		PNP output/Wiring bottom entry	—	ISE35-N-65-MLA [ISE35-N-65-M (Switch body only)] ^{Note 4)}								
		PNP output/Wiring top entry	—	ISE35-R-65-MLA [ISE35-R-65-M (Switch body only)] ^{Note 4)}								
Float type ^{Note 5)} auto drain	N.O.	—	AD38			AD48						
	N.C.	AD17	AD27	AD37		AD47						
Attachments	Spacer		Y100	Y200	Y300		Y400	Y500	Y600			
	Check valve ^{Note 6)} ^{Note 7)}		—	AKM2000-□01 (□02)	AKM3000-(□01) □02		AKM4000-(□02) □03	—	—	—	—	
	Pressure switch ^{Note 7)}		—	IS1000M-20	IS1000M-30		IS1000M-40	IS1000M-50		IS1000M-60		
	T-interface ^{Note 6)} ^{Note 7)}		Y110-M5	Y210-□01 (□02)	Y310-(□01) □02		Y410-(□02) □03	Y510-(□02) □03	Y610-□03 (□04)	Y610-(□03) □04		
	3-port valve for residual pressure release ^{Note 7)}		—	VHS20-□01 □02	VHS30-□02 □03		□02 VHS40-□03 □04	VHS40-□06	VHS50-□06 □10	—	—	
	Piping adapter ^{Note 7)}		E100-M5	□01 E200-□02 □03	□02 E300-□03 □04		□02 E400-□03 □04 □06	E500-□06	E600-□06 □10			
	Pressure switch with piping adapter ^{Note 7)}		—	□01 IS1000E-20□02 □03	□02 IS1000E-30□03 □04		□02 IS1000E-40□03 □04 □06	—	—	—	—	
	Cross spacer ^{Note 7)}		Y14-M5	Y24-□01 □02	Y34-□01 □02		Y44-□02 □03	Y54-□03 □04	—	—	—	

- Note 1) □ in part numbers for a round pressure gauge indicates a type of connection thread. No indication is necessary for R; however, indicate N for NPT.
Please contact SMC regarding the connection thread NPT and pressure gauge supply for psi unit specifications.
- Note 2) Including one O-ring and 2 mounting screws
- Note 3) Standard pressure gauge
- Note 4) Lead wire with connector (2 m), adapter, lock pin, O-ring (1 pc.), mounting screw (2 pcs.) are attached. []: Switch body only.
Also, regarding how to order the digital pressure switch, please refer to Best Pneumatics No.5.
- Note 5) Minimum operating pressure: N.O. type=0.1 MPa; N.C. type=0.1 MPa (AD17/27) and 0.15 MPa (AD37/47). Please contact SMC for psi and °F unit specifications.
- Note 6) For F.R.L. units, port sizes without () are standard specifications.
- Note 7) Separate interfaces are required for modular unit.

Air Filter + Regulator + Lubricator ACG20/30/40

Options/Attachments Part No.

Description	Options/Attachments part no.				
	Model	ACG20	ACG30	ACG40	
Pressure gauge ^{Note 1)}	Standard	0 to 1.0 MPa	GB2-10AS	GB3-10AS	GB4-10AS
	Optional	0 to 0.3 MPa	GB2-3AS	GB3-3AS	GB4-3AS
Options	Float type auto drain ^{Note 2)}	N.C.	AD27	AD37	AD47
		N.O.	—	AD38	AD48
Attachments	Spacer		Y200	Y300	Y400
	Spacer with bracket		Y200T	Y300T	Y400T
	Check valve ^{Note 3, 4)}		AKM2000-□01, (□02)	AKM3000-(□01), □02	AKM4000-(□02), □03
	Pressure switch ^{Note 4, 5)}		IS10M-20	IS10M-30	IS10M-40
	Residual pressure relief 3 port valve ^{Note 4)}		VHS20-□01, □02	VHS30-□02, □03	VHS40-□02, □03, □04

- Note 1) Contact SMC regarding the connection thread NPT and pressure gauge supply for psi unit specifications.
- Note 2) Minimum operating pressure: 0.1 MPa for N.O. type, 0.1 MPa for N.C. type (AD27) and 0.15 MPa for N.C. type (AD37 and 47). Contact SMC for psi and °F specifications.
- Note 3) For F.R.L. units, port sizes not in () are for standard application.
- Note 4) Separate spacers are required for modular unit.
- Note 5) Pressure switch cannot be mounted on the inlet and outlet sides of an ARG with an upward facing handle (optional specification: -Y).

Air Combination

Series ACG

Filter Regulator + Lubricator ACG20A/30A/40A

Options/Attachments Part No.

Description		Model	Options/Attachments part no.		
			ACG20A	ACG30A	ACG40A
Pressure gauge ^{Note 1)}	Standard	0 to 1.0 MPa	GB2-10AS	GB3-10AS	GB4-10AS
	Optional	0 to 0.3 MPa	GB2-3AS	GB3-3AS	GB4-3AS
Options Float type auto drain ^{Note 2)}		N.C.	AD27	AD37	AD47
		N.O.	-	AD38	AD48
Attachments Spacer			Y200	Y300	Y400
			Y200T	Y300T	Y400T
			AKM2000-□01, □02	AKM3000-□01, □02	AKM4000-□02, □03
			VHS20-□01, □02	VHS30-□02, □03	VHS40-□02, □03, □04

Note 1) Contact SMC regarding the connection thread NPT and pressure gauge supply for psi unit specifications.

Note 2) Minimum operating pressure: 0.1 MPa for N.O. type, 0.1 MPa for N.C. type (AD27) and 0.15 MPa for N.C. type (AD37 and 47). Contact SMC for psi and °F specifications.

Note 3) For F.R.L. units, port sizes not in () are for standard application.

Note 4) Separate spacers are required for modular unit.

Air Filter + Regulator ACG20B/30B/40B

Options/Attachments Part No.

Description		Model	Options/Attachments part no.		
			ACG20B	ACG30B	ACG40B
Pressure gauge ^{Note 1)}	Standard	0 to 1.0 MPa	GB2-10AS	GB3-10AS	GB4-10AS
	Optional	0 to 0.3 MPa	GB2-3AS	GB3-3AS	GB4-3AS
Options Float type auto drain ^{Note 2)}		N.C.	AD27	AD37	AD47
		N.O.	-	AD38	AD48
Attachments Spacer			Y200	Y300	Y400
			Y200T	Y300T	Y400T
			IS10M-20	IS10M-30	IS10M-40
			VHS20-□01, □02	VHS30-□02, □03	VHS40-□02, □03, □04

Note 1) Contact SMC regarding pressure gauge supply for psi unit specifications.

Note 2) Minimum operating pressure: 0.1 MPa for N.O. type, 0.1 MPa for N.C. type (AD27) and 0.15 MPa for N.C. type (AD37 and 47). Contact SMC for psi and °F specifications.

Note 3) Separate spacers are required for modular unit.

Note 4) Pressure switch cannot be mounted on the inlet and outlet sides of an ARG with an upward facing handle (optional specification: -Y).

Air Filter + Mist Separator + Regulator ACG20C/30C/40C

Options/Attachments Part No.

Description		Model	Options/Attachments part no.		
			ACG20C	ACG30C	ACG40C
Pressure gauge ^{Note 1)}	Standard	0 to 1.0 MPa	GB2-10AS	GB3-10AS	GB4-10AS
	Optional	0 to 0.3 MPa	GB2-3AS	GB3-3AS	GB4-3AS
Options Float type auto drain ^{Note 2)}		N.C.	AD27	AD37	AD47
		N.O.	-	AD38	AD48
Attachments Spacer			Y200	Y300	Y400
			Y200T	Y300T	Y400T
			IS10M-20	IS10M-30	IS10M-40
			VHS20-□01, □02	VHS30-□02, □03	VHS40-□02, □03, □04

Note 1) Contact SMC regarding pressure gauge supply for psi unit specifications.

Note 2) Minimum operating pressure: 0.1 MPa for N.O. type, 0.1 MPa for N.C. type (AD27) and 0.15 MPa for N.C. type (AD37 and 47). Contact SMC for psi and °F specifications.

Note 3) Separate spacers are required for modular unit.

Note 4) Pressure switch cannot be mounted on the inlet and outlet sides of an ARG with an upward facing handle (optional specification: -Y).

Filter Regulator + Mist Separator ACG20D/30D/40D

Options/Attachments Part No.

Description		Model	Options/Attachments part no.		
			ACG20D	ACG30D	ACG40D
Pressure gauge ^{Note 1)}	Standard	0 to 1.0 MPa	GB2-10AS	GB3-10AS	GB4-10AS
	Optional	0 to 0.3 MPa	GB2-3AS	GB3-3AS	GB4-3AS
Options Float type auto drain ^{Note 2)}		N.C.	AD27	AD37	AD47
		N.O.	-	AD38	AD48
Attachments Spacer			Y200	Y300	Y400
			Y200T	Y300T	Y400T
			VHS20-□01, □02	VHS30-□02, □03	VHS40-□02, □03, □04

Note 1) Contact SMC regarding pressure gauge supply for psi unit specifications.

Note 2) Minimum operating pressure: 0.1 MPa for N.O. type, 0.1 MPa for N.C. type (AD27) and 0.15 MPa for N.C. type (AD37 and 47). Contact SMC for psi and °F specifications.

Note 3) Separate spacers are required for modular unit.

Regulator with Built-in Pressure Gauge

ARG20(K)/30(K)/40(K)

Replacement
Procedure is
P.431

Construction

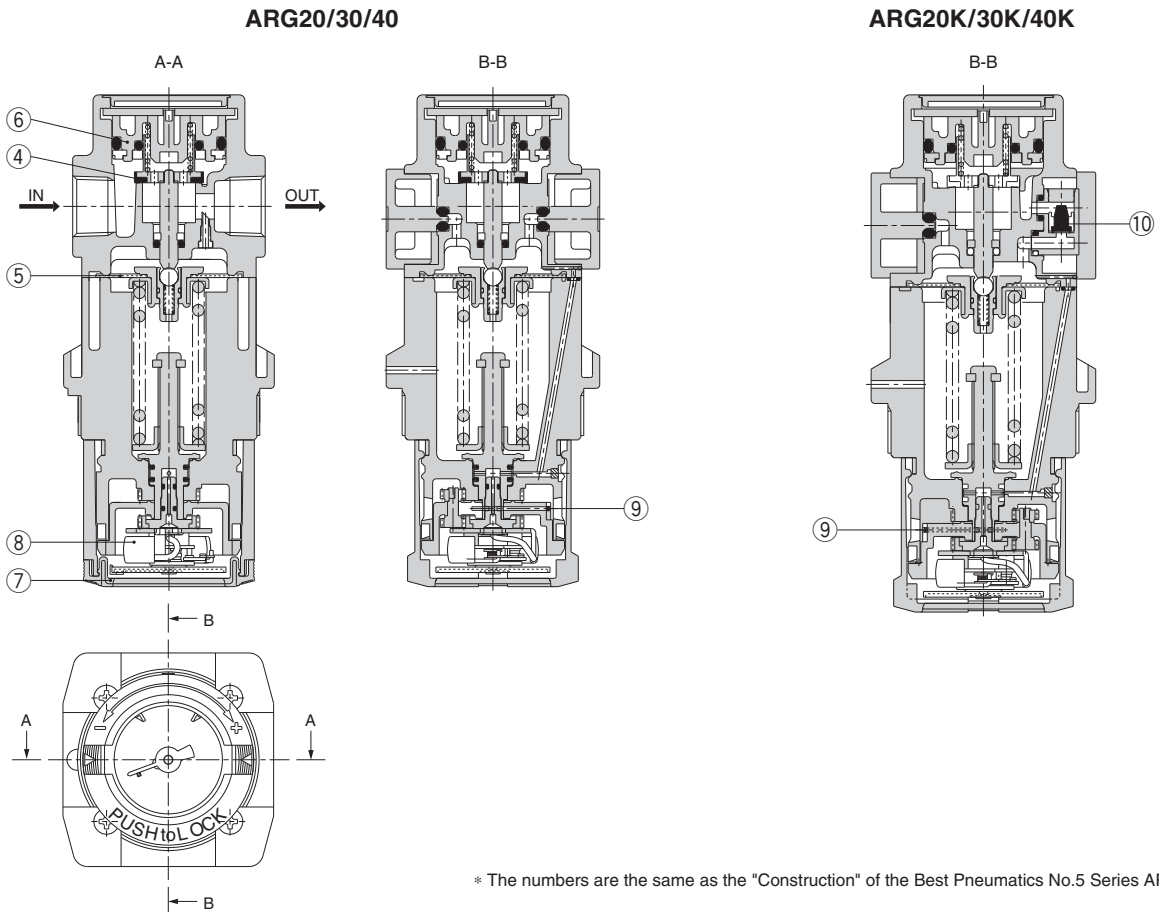

Replacement Parts

No.	Description	Material	Qty.	Part no.			Note
				ARG20(K)	ARG30(K)	ARG40(K)	
4	Valve	Brass, HNBR	1	AR20P-410S	AR30P-410S	AR40P-410S	
5	Diaphragm assembly	Weather resistant NBR	1	AR20P-150AS	AR30P-150AS	AR40P-150AS	
6	Valve guide assembly	POM, NBR	1	AR20P-050AS	AR30P-050AS	AR40P-050AS	
7	Pressure gauge cover	PC	1	ARG20P-400S	ARG30P-400S	ARG40P-400S	
8	Pressure gauge ^{Note 1)}	—	1	GB2-10AS	GB3-10AS	GB4-10AS	
9	Clip	Stainless steel	1	ARG20P-420S	ARG30P-420S	ARG40P-420S	
10	Check valve assembly ^{Note 2)}	—	1	AR20KP-020AS			ARG20K, 30K, 40K

Note 1) Only the standard part numbers are listed for the pressure gauges.

Note 2) Check valve assembly contains check valve, check valve cover and its screws (2 pcs).

Options/Part No.

		Applicable model		ARG20(K)	ARG30(K)	ARG40(K)
Option						
Bracket assembly ^{Note 1)}				ARG20P-270AS	ARG30P-270AS	ARG40P-270AS
Set nut				ARG20P-260S	ARG30P-260S	ARG40P-260S
Pressure gauge	Pressure gauge display range	Standard	0 to 1.0 MPa	GB2-10AS	GB3-10AS	GB4-10AS
			0 to 0.3 MPa	GB2-3AS	GB3-3AS	GB4-3AS
		Optional	0 to 150 psi	GB2-P10AS	GB3-P10AS	GB4-P10AS
			0 to 45 psi	GB2-P3AS	GB3-P3AS	GB4-P3AS

Note 1) Assembly includes a bracket and set nuts.

Filter Regulator with Built-in Pressure Gauge

AWG20/30/40

Replacement
Procedure is
P.437

Construction

AWG20

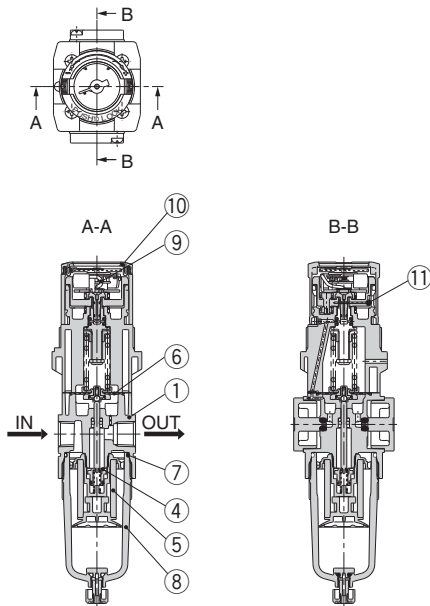

AWG30/40

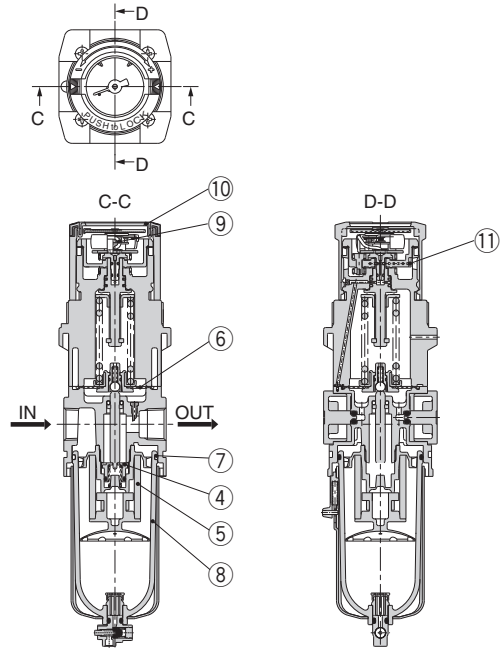

* The numbers are the same as the "Construction" of the Best Pneumatics No.5 Series AWG.

Replacement Parts

No.	Description	Material	Qty.	Part no.			Note
				AWG20	AWG30	AWG40	
4	Valve assembly	Brass, HNBR	1	AW20P-340AS	AW30P-340AS	AW40P-340AS	
5	Filter element	Non-woven fabric	1	AF20P-060S	AF30P-060S	AF40P-060S	
6	Diaphragm assembly	Weather resistant NBR	1	AR20P-150AS	AR30P-150AS	AR40P-150AS	
7	Bowl O-ring	NBR	1	C2SFP-260S	C3SFP-260S	C4SFP-260S	
8	Bowl assembly ^{Note 1)}	PC	1	C2SF	C3SF ^{Note 2)}	C4SF ^{Note 2)}	
9	Pressure gauge ^{Note 3)}	—	1	GB2-10AS	GB3-10AS	GB4-10AS	
10	Pressure gauge cover	PC	1	ARG20P-400S	ARG30P-400S	ARG40P-400S	
11	Clip	Stainless steel	1	ARG20P-420S	ARG30P-420S	ARG40P-420S	

Note 1) Including O-ring. Contact SMC regarding the bowl assembly supply for psi and °F unit specifications.

Note 2) Bowl assembly for AWG30/40 includes a bowl guard (steel band material).

Note 3) Only the standard part numbers are listed in the pressure gauges. For the semi-standard part numbers, refer to the optional part numbers.

Options/Part No.

Option		Applicable model		AWG20	AWG30	AWG40
Bracket assembly ^{Note 1)}				ARG20P-270AS	ARG30P-270AS	ARG40P-270AS
Set nut				ARG20P-260S	ARG30P-260S	ARG40P-260S
Pressure gauge	Pressure gauge display range	Standard	0 to 1.0 MPa	GB2-10AS	GB3-10AS	GB4-10AS
			0 to 0.3 MPa	GB2-3AS	GB3-3AS	GB4-3AS
		Optional	0 to 150 psi	GB2-P10AS	GB3-P10AS	GB4-P10AS
			0 to 45 psi	GB2-P3AS	GB3-P3AS	GB4-P3AS
Float type auto drain ^{Note 2)}			N.O.	—	AD38	AD48
			N.C.	AD27	AD37	AD47

Note 1) Assembly includes a bracket and set nuts.

Note 2) Minimum operating pressure: N.O. type—0.1 MPa; N.C. type—0.1 MPa (AD27) and 0.15 MPa (AD37/47). Contact SMC regarding the specifications for psi unit and °F.

Filter Regulator with Built-in Pressure Gauge with Backflow Function

AWG20K/30K/40K

Construction

AWG20K

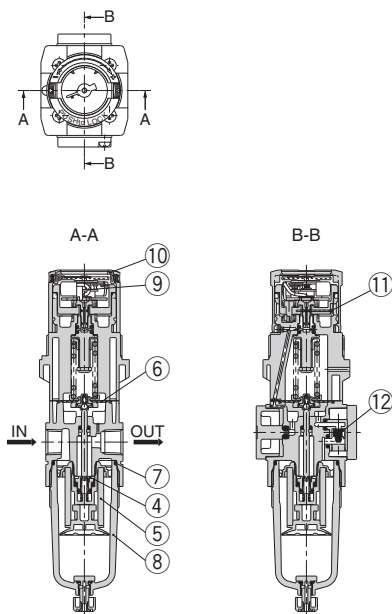

AWG30K/40K

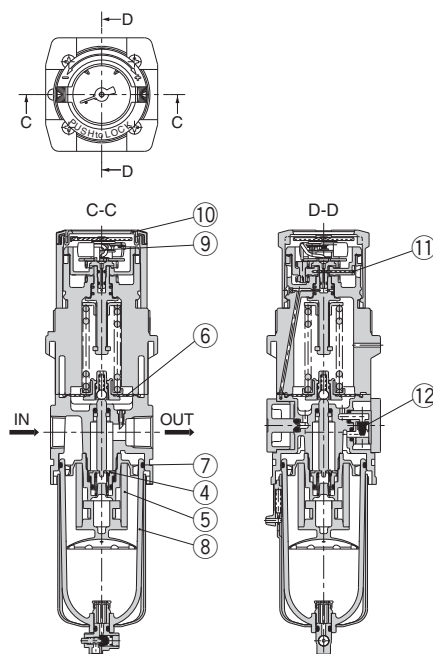

* The numbers are the same as the "Construction" of the Best Pneumatics No.5 Series AWG.

Replacement Parts

No.	Description	Material	Qty.	Part no.			Note
				AWG20K	AWG30K	AWG40K	
4	Valve assembly	Brass, HNBR	1	AW20P-340AS	AW30P-340AS	AW40P-340AS	
5	Filter element	Non-woven fabric	1	AF20P-060S	AF30P-060S	AF40P-060S	
6	Diaphragm assembly	Weather resistant NBR	1	AR20P-150AS	AR30P-150AS	AR40P-150AS	
7	Bowl O-ring	NBR	1	C2SFP-260S	C3SFP-260S	C4SFP-260S	
8	Bowl assembly ^{Note 1)}	PC	1	C2SF	C3SF ^{Note 2)}	C4SF ^{Note 2)}	
9	Pressure gauge ^{Note 3)}	—	1	GB2-10AS	GB3-10AS	GB4-10AS	
10	Pressure gauge cover	PC	1	ARG20P-400S	ARG30P-400S	ARG40P-400S	
11	Clip	Stainless steel	1	ARG20P-420S	ARG30P-420S	ARG40P-420S	
12	Check valve assembly	—	1	AR20KP-020AS			

Note 1) Including O-ring. Contact SMC regarding the bowl assembly supply for psi and °F unit specifications.

Note 2) Bowl assembly (AWG30K/40K) includes a bowl guard (steel band material).

Note 3) Only the standard part numbers are listed for the pressure gauges. For the semi-standard part numbers, refer to the optional part numbers.

Options/Part No.

Option		Applicable model		AWG20K	AWG30K	AWG40K
Bracket assembly ^{Note 1)}				ARG20P-270AS	ARG30P-270AS	ARG40P-270AS
Set nut				ARG20P-260S	ARG30P-260S	ARG40P-260S
Pressure gauge	Pressure gauge display range	Standard	0 to 1.0 MPa	GB2-10AS	GB3-10AS	GB4-10AS
			0 to 0.3 MPa	GB2-3AS	GB3-3AS	GB4-3AS
		Optional	0 to 150 psi	GB2-P10AS	GB3-P10AS	GB4-P10AS
			0 to 45 psi	GB2-P3AS	GB3-P3AS	GB4-P3AS
Float type auto drain ^{Note 2)}		N.O.	—	AD38	AD48	
		N.C.	AD27	AD37	AD47	

Note 1) Assembly includes a bracket and set nuts.

Note 2) Minimum operating pressure: N.O. type—0.1 MPa; N.C. type—0.1 MPa (AD27) and 0.15 MPa (AD37/47). Contact SMC regarding the specifications for psi unit and °F.

Pilot Operated Regulator

AR425 to 935

Replacement
Procedure is
p.444

Construction

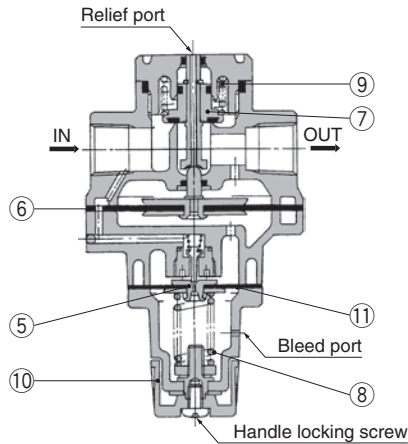

* The numbers are the same as the "Construction" of the Best Pneumatics No.5 Series AR.

Replacement Parts

No.	Description	Material	Qty.	Part no.				Note
				AR425/435	AR625/635	AR825/835	AR925/935	
5, 11	Exhaust valve assembly ^{Note 1)}	—	1	132586A	132586A	132586A	132586A	
6	Main valve side diaphragm assembly	—	1	132581A	132659A	13275A	13285A	
7	Valve assembly	—	1	132572A	132653A	132752A	132829A	
8	Adjusting spring	Steel wire	1	135053(AR425) 135025(AR435)	135053(AR625) 135025(AR635)	135053(AR825) 135025(AR835)	135053(AR925) 135025(AR935)	
9	Valve spring	Stainless steel	1	135211	132656	132713	13289	
10	Handle	ABS	1	13414				

Note 1) Diaphragm is included.

Options/Part No.

Description	Model	Part no.			
		AR4□5	AR6□5	AR8□5	AR9□5
Bracket		B24P	B25P	—	—
Pressure gauge with limit indicator ^{Note 1)}		G46-10-□02 (Max. 1.0 MPa), G46-2-□02 (Max. 0.2 MPa)			

Note 1) • In the gauge part no. (e.g. G46-10-□02), □ indicate kind of the connecting thread. Put nothing for Rc and "N" for NPT thread.

• Please consult with SMC for NPT pressure gauge.

Note 2) Use caution not to tighten excessively when mounting a pressure gauge, otherwise it may result in a breakdown. Use a pipe tape for sealing.
Recommended torque: 12 to 14 N·m.

Actuators

Modular F.R.L.
Pressure Control Equipment

Air Preparation
Equipment

Industrial Filters

Replacement
Procedure

Actuators

Modular F.R.L.
Pressure Control Equipment

Industrial Filters

AMR3000 to 6000

Replacement
Procedure is
p.448

Construction

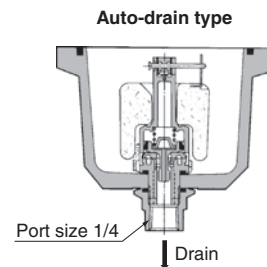
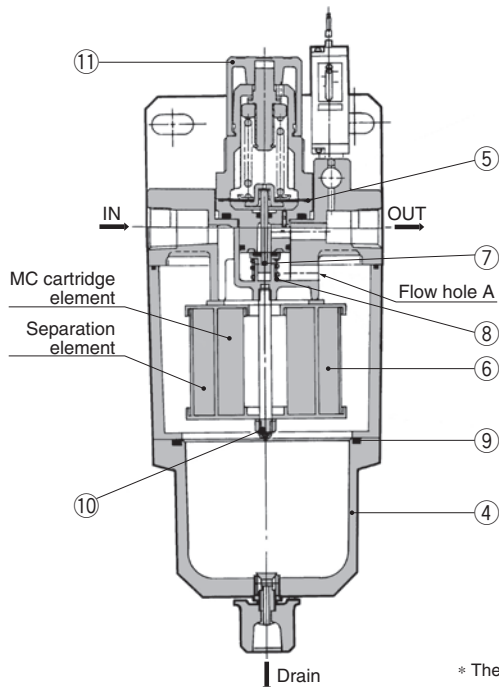

* The numbers are the same as the "Construction" of the Best Pneumatics No.5 Series AMR.

Replacement Parts

No.	Description	Material	Qty	Part no.				Note
				AMR3000	AMR4000	AMR5000	AMR6000	
4	Bowl assembly	Aluminum die-casted	1	13573A	13553A	13583A	13563A	
5	Diaphragm assembly	Weather resistant NBR	1	1349161A	131515A	131515A	131614A	
6	Element ^{Note)}	—	1	13579	135511	13589	13569	
7	Valve assembly	Brass, HNBR	1	135711A	13154A	135811A	135614-1A	
8	Valve spring	Stainless steel	1	135011	131514	131613	135413	
9	O-ring	NBR	1	G75	G90	G100	G115	
10	Gasket	Fiber	1	135714	635327	635327	63555	
11	Handle	POM	1	1349167	131534	131534	131634	

Note) The MC cartridge element and the separation element are integrated.

Accessory (Standard)/Part No.

Model name	Model	AMR3000	AMR4000	AMR5000	AMR6000
Bracket		13576	13556	13587	13568
Pressure gauge ^{Note 5, 6)}	1.0MPa	G36-10-□01		G46-10-□02	

Accessory (Option)/Part No.

Model name	Model	AMR3000	AMR4000	AMR5000	AMR6000
Adapter assembly ^{Note 7)}		1/4:E3-□02 3/8:E3-□03	1/4:E4-□02 3/8:E4-□03 1/2:E4-□04	1/2:E5-□04 3/4:E5-□06	3/4:E6-□06 1:E6-□10
Float style auto drain (AMR□100) ^{Note 8)}		AD33-X203	AD33-X202	AD33-X210	AD33-X201
Compact pressure switch		IS1000-01 (0.4 MPa setting)			
Elbow (R x Rc) ^{Note 9)}		135510		135613	

Note 5) □ in the gauge part number (e.g. G36-10-□01) indicates thread. Specify no symbol for "Rc", and "N" for "NPT".

• Please consult with SMC if "NPT" gauge is required.

Note 6) Use caution not to tighten excessively when mounting a pressure gauge, otherwise it may result in a breakdown. Use a pipe tape for sealing.

Recommended tightening torque for pressure regulator: R 1/8 = 7 to 9 N·m, R 1/4 = 12 to 14 N·m

Note 7) Piping adapter, O-ring, Hexagon socket bolt, Hexagon socket bolt assembly. These are shipped together with products. "□" in the gauge part number indicates thread type. Specify no symbol for "Rc", "N" for "NPT", and "G" for "F".

Note 8) Min. operating pressure = 0.1 MPa

Note 9) If a compact pressure switch is mounted later on, an elbow (R x Rc) is necessary.

Compact Manifold Regulator/Centralized Supply Type

Series ARM5A

Replacement
Procedure is
p.449

Construction

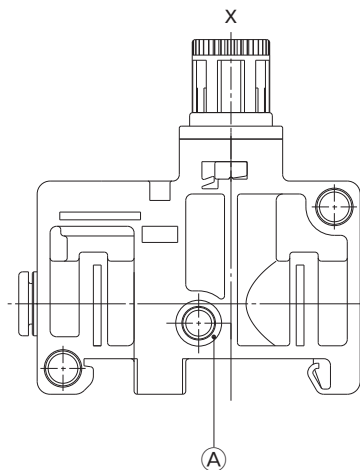
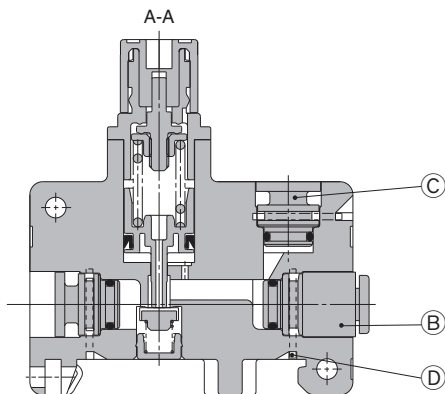
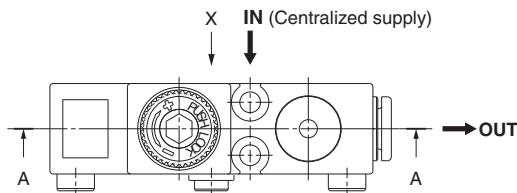

Replacement Parts

No.	Description	Material	Qty.	Part no.
A	O-ring	NBR	1	136019
B	Fitting assembly	—	1	See below
C	Port plug	PBT, HNBR	1	See below
D	Clip	Stainless steel	3	136010

* The numbers are the same as the "Construction" of the Best Pneumatics No.5 Series ARM5A.

One-touch Fittings for Centralized Supply Block

VVQ1000-51A - [] C6

One-touch fittings for centralized supply block

Fitting type

Nil	Straight
L1	Elbow

Fitting size

Symbol	Size
C6	ø6
C8	ø8
N7	ø1/4
N9	ø5/16



Straight type

Elbow type

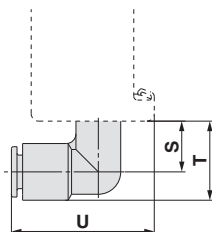
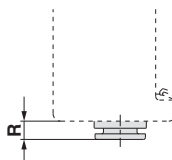

Port Plug

VVQ0000-58A

Single unit regulator/
Port plug for regulator block

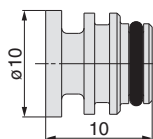
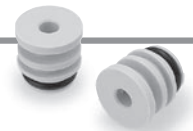

Note) The O-ring is attached. Refer to page 449 for details of the replacement.

Fitting size	One-touch fittings for centralized supply block			
	Straight	Elbow	Elbow	Elbow
	R	S	T	U
ø4, ø5/32	—	—	—	—
ø6	3	12.5	19	35.5
ø1/4	3	12.5	19	35.5
ø8, ø5/16	5	13.5	21	38.5

Note) The O-ring is attached. Refer to page 449 for details of the replacement.

Compact Manifold Regulator/Individual Supply Type

Series ARM5B

Replacement
Procedure is
p.449

Construction

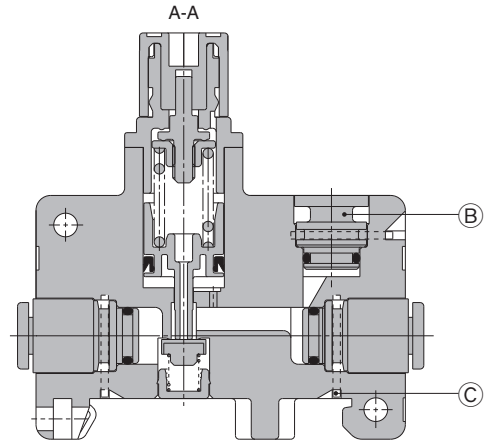
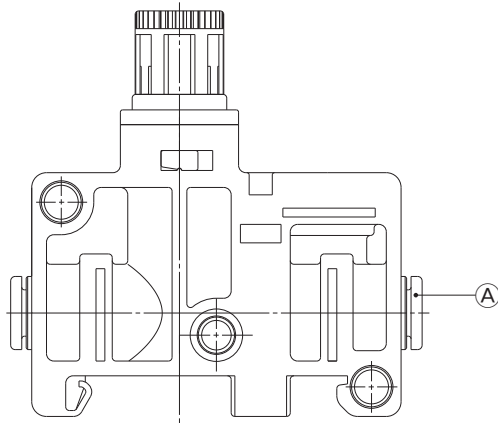
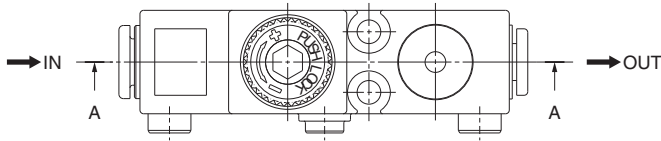

Replacement Parts

No.	Description	Material	Qty.	Part no.
A	Fitting assembly	—	2	See below
B	Port plug	PBT, HNBR	1	See below
C	Clip	Stainless steel	3	136010

* The numbers are the same as the "Construction" of the Best Pneumatics No.5 Series ARM5B.

One-touch Fittings for Regulator Block

VVQ1000-50A - [] C4

One-touch fittings for regulator block

Fitting type	
Nil	Straight
L1	Elbow



Straight type

Fitting size	
Symbol	Size
C4	ø4
C6	ø6
N3	ø5/32
N7	ø1/4

Elbow type

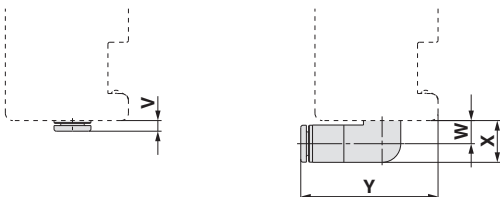

Port Plug

VVQ0000-58A

Single unit regulator/
Port plug for regulator block

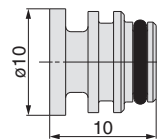
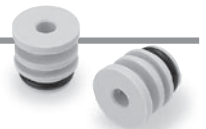

Note) The O-ring is attached. Refer to page 449 for details of the replacement.

Fitting size	One-touch fittings for regulator block			
	Straight	Elbow	Elbow	Elbow
	V	W	X	Y
ø4, ø5/32	2.5	6	11	35.5
ø6	3	6.5	11	36
ø1/4	6.5	6	11.5	38.5
ø8, ø5/16	—	—	—	—

Note) The O-ring is attached. Refer to page 449 for details of the replacement.

Series ARM5S

Replacement
Procedure is
p.449

Construction

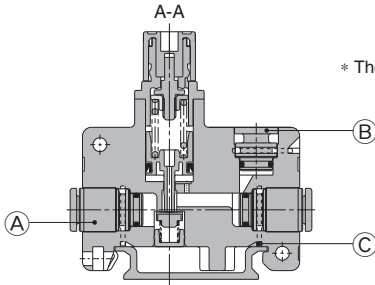
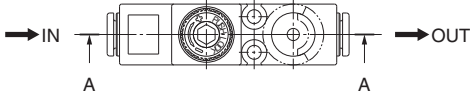

* The numbers are the same as the "Construction" of the Best Pneumatics No.5 Series ARM5S.

Replacement Parts

No.	Description	Material	Qty.	Part no.
A	Fitting assembly	—	2	See below
B	Port plug	PBT, HNBR	1	See below
C	Clip	Stainless steel	3	136010

One-touch Fittings for Regulator

VVQ1000-50A - [] C4

One-touch fittings
for regulator

Fitting type

Nil	Straight
L1	Elbow

Fitting size

C4	ø4
C6	ø6
N3	ø5/32
N7	ø1/4

Straight type

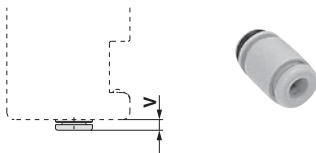

Elbow type

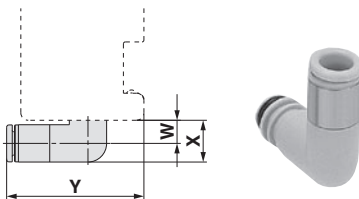

Port Plug

VVQ0000-58A

Single unit regulator/
Port plug for regulator block

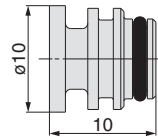

Note) The O-ring is attached.
Refer to page 449 for details of the replacement.

Fitting size	One-touch fittings for regulator			
	Straight	Elbow	Elbow	Elbow
	V	W	X	Y
ø4, ø5/32	2.5	6	11	35.5
ø6	3	6.5	11	36
ø1/4	6.5	6	11.5	38.5
ø8, ø5/16	—	—	—	—

Note) The O-ring is attached.
Refer to page 449 for details of the replacement.

Series ARM10

Replacement
Procedure is
P.453

Construction

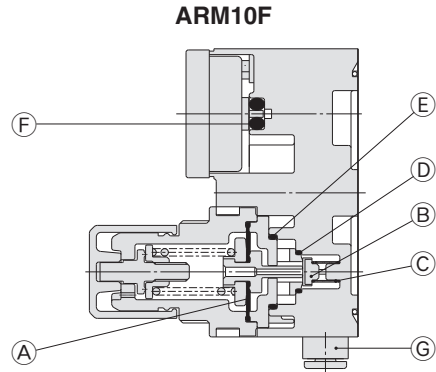
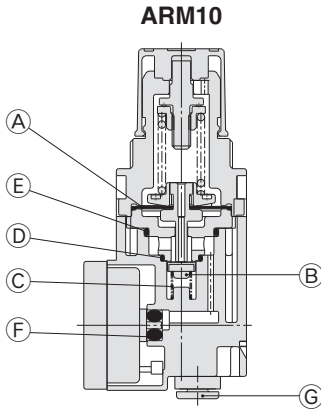

Replacement Parts

No.	Description	Material	Part no.	Note
A	Diaphragm assembly	Weather resistant	136126A	Relieving type
		NBR, POM	136126-1A	Non-relieving type
B	Valve	HNBR, Aluminum alloy	136127-30#1	
C	Valve spring	Stainless steel	136131	
D	O-ring	NBR	136146	Standard model
		HNBR	136146-30	Oil-free specification
E	O-ring	NBR	136147	Standard model
		HNBR	136147-30	Oil-free specification
F	O-ring	NBR	136148	Standard model
		HNBR	136148-30	Oil-free specification
		NBR	KA01731	Standard model for digital pressure switch
		HNBR	KA01613	Oil-free spec. for digital pressure switch
G	Fitting assembly	—	The right reference	

* The numbers are the same as the "Construction" of the Best Pneumatics No.5 Series ARM10.

One-touch Fittings for Regulator

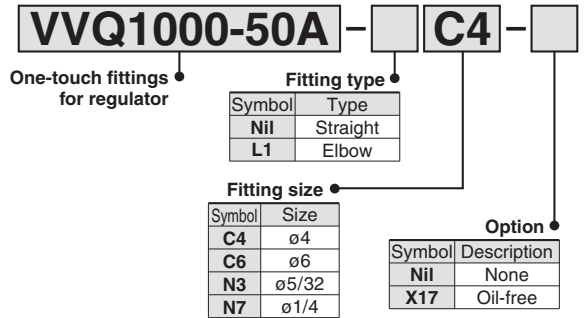

ARM10

Straight type

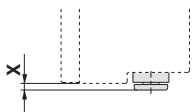

Fitting size	X
ø4, ø5/32	2
ø6	2
ø1/4	6

Elbow type

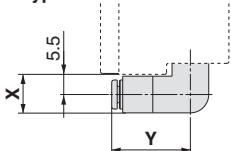

Fitting size	X	Y
ø4, ø5/32	10.5	21.5
ø6	10.5	22
ø1/4	10.5	24.5

ARM10F

Straight type

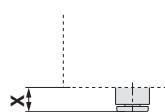

Fitting size	X
ø4, ø5/32	7
ø6	7
ø1/4	11

Elbow type

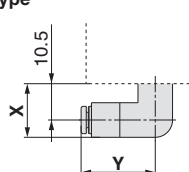

Fitting size	X	Y
ø4, ø5/32	15.5	21.5
ø6	15.5	22
ø1/4	15.5	24.5

Series ARM11A

Replacement
Procedure is
p.453

Construction

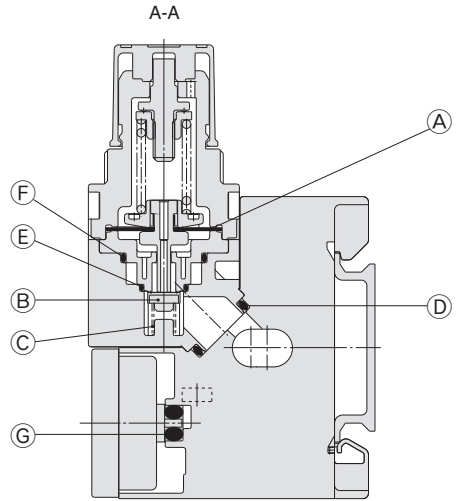
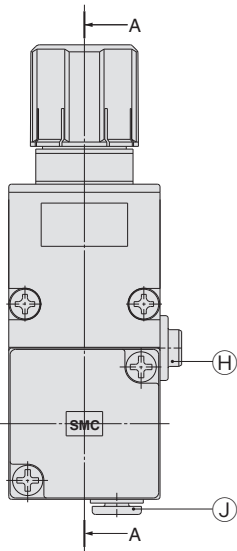
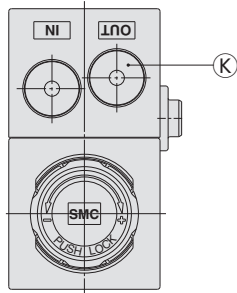

* The numbers are the same as the "Construction" of the Best Pneumatics No.5 Series ARM11A.

Replacement Parts

No.	Description	Material	Part no.	Note
A	Diaphragm assembly	Weather resistant NBR, POM	136126A	Relieving type
			136126-1A	Non-relieving type
B	Valve	HNBR, Aluminum alloy	136127-30#1	
C	Valve spring	Stainless steel	136131	
D	Gasket	HNBR	136137-30	
E	O-ring	NBR	136146	Standard model
		HNBR	136146-30	Oil-free specification
F	O-ring	NBR	136147	Standard model
		HNBR	136147-30	Oil-free specification
G	O-ring	NBR	136148	Standard model
		HNBR	136148-30	Oil-free specification
		NBR	KA01731	Standard model for digital pressure switch
		HNBR	KA01613	Oil-free spec. for digital pressure switch
H	O-ring	NBR	136149	Standard model
		HNBR	136149-30	Oil-free specification
J	Fitting assembly	—	Refer to page 239.	
K	Port plug	PBT/HNBR	Refer to page 239.	

Compact Manifold Regulator/Individual Supply Type

Series ARM11B

Replacement
Procedure is
p.453

Construction

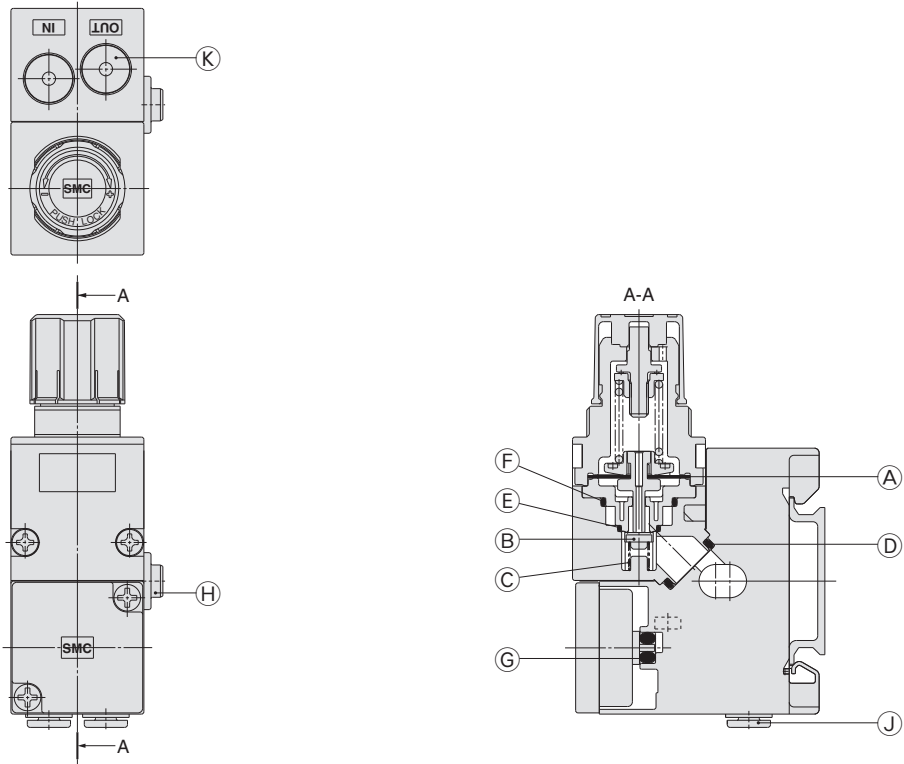

* The numbers are the same as the "Construction" of the Best Pneumatics No.5 Series ARM11B.

Replacement Parts

No.	Description	Material	Part no.	Note
A	Diaphragm assembly	Weather resistant NBR, POM	136126A	Relieving type
			136126-1A	Non-relieving type
B	Valve	HNBR, Aluminum alloy	136127-30#1	
C	Valve spring	Stainless steel	136131	
D	Gasket	HNBR	136137-30	
E	O-ring	NBR	136146	Standard model
		HNBR	136146-30	Oil-free specification
F	O-ring	NBR	136147	Standard model
		HNBR	136147-30	Oil-free specification
G	O-ring	NBR	136148	Standard model
		HNBR	136148-30	Oil-free specification
		NBR	KA01731	Standard model for digital pressure switch
H	O-ring	HNBR	KA01613	Oil-free spec. for digital pressure switch
		NBR	136149	Standard model
J	Fitting assembly	HNBR	136149-30	Oil-free specification
			—	Refer to page 239.
K	Port plug	PBT/HNBR	Refer to page 239.	

Compact Manifold Regulator Series ARM11A/B

Options

Replacement
Procedure is
P.453

One-touch Fittings for Regulator Block

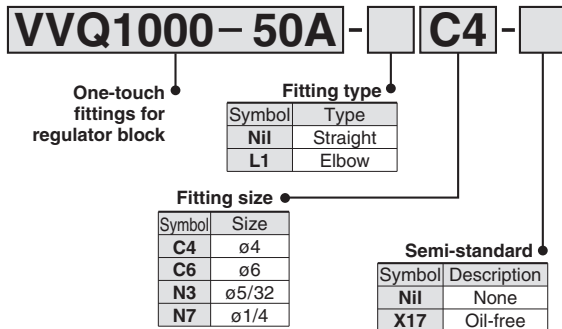

Straight type

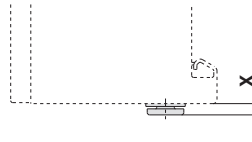

Fitting size	X
ø4, ø5/32	3
ø6	3
ø1/4	7

Elbow type

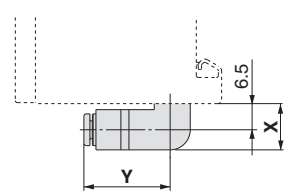

Fitting size	X	Y
ø4, ø5/32	11.5	19
ø6	11.5	19.5
ø1/4	11.5	22

One-touch Fittings for Common Supply Block

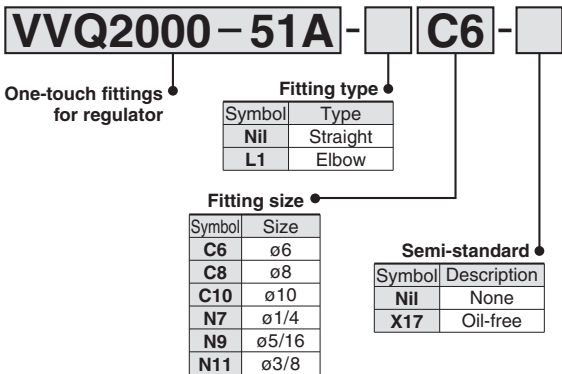

Straight type

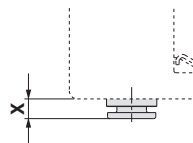

Fitting size	X
ø6	5
ø8, ø5/16	5
ø10, ø3/8	5.5
ø1/4	5

Elbow type

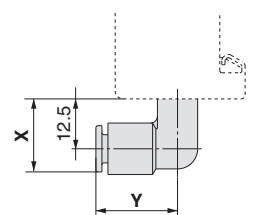

Fitting size	X	Y
ø6	19	20
ø8, ø5/16	20	23
ø10, ø3/8	22	26
ø1/4	19	20.5

Port Plug

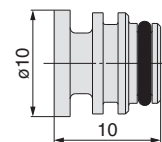
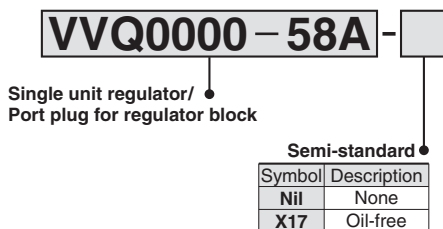

Actuators

Modular F.R.L.
Pressure Control Equipment

Air Preparation
Equipment

Industrial Filters

Replacement
Procedure

Actuators

Modular F.R.L.
Pressure Control Equipment

Industrial Filters

Air Preparation Equipment Industrial Filters

Air Preparation Equipment

1 Indication of replacement of elements, inspection items..... P.242

2 Troubleshooting P.243

3 Details of replacement parts

AMJ	Drain Separator for Vacuum	P.244
AMG	Water Separator	P.245
AFF	Main Line Filter	P.246
AM	Mist Separator	P.247
AMD	Micro Mist Separator	P.248
AMH	Micro Mist Separator with Pre-filter	P.249
AME	Super Mist Separator	P.250
AMF	Odor Removal Filter	P.251

Industrial Filters

1 Indication of replacement of elements, inspection items..... P.253

2 How to arrange replacement element kit number selection

How to Select Element Order Number for Replacement	P.254
Standard Elements: Sintered Metal/Fiber	P.256
Standard Elements: Paper/Micromesh	P.257

3 Details of replacement parts

FGD	Industrial Filter: Vessel Series	P.258
FGE	Industrial Filter: Vessel Series	P.260
FGG	Industrial Filter: Vessel Series	P.262
FGA	Industrial Filter: Vessel Series	P.264
FGB	Industrial Filter: Vessel Series	P.265
FGC	Industrial Filter: Vessel Series	P.266
FGF	Bag Filter	P.267
FGH	High Precision Filter for Liquids	P.269
FQ1	Quick Change Filter	P.271
FN1	Low Maintenance Filter	P.273
FN4	Low Maintenance Filter	P.273

Actuators

Modular F.R.L.
Pressure Control Equipment

Air Preparation
Equipment

Industrial Filters

Replacement
Procedure

Actuators

Modular F.R.L.
Pressure Control Equipment

Industrial Filters

Air Preparation Equipment

1 Indication of replacement of elements, inspection items

The following describes the general contents of the element replacement and regular check.

Main line filter/mist separator/micro mist separator replacement standards and inspection items

■ Replacement standards

<Element replacement timing>

- a. For AFF2C to 22C, 37B, 75B, AM□150C to 550C, 650, and 850

The pressure drop reaches 0.1 MPa or two years have elapsed after operation start, whichever comes earlier. [The pressure drop can be checked using the equipment with the element service indicator (-T) or differential pressure gauge (made to order specifications).]

- b. For AFF75A to 220A, AMD800 to AMD1000, AMD801, and 901

The pressure drop reaches 0.1 MPa or two years have elapsed after operation start, whichever comes earlier. Check the pressure drop using the pressure gauge. (Equipment with pressure gauge:-G)

- c. For AME

If red spots appear on the element surface before the standards (a) shown above are satisfied, replace the element.

- d. For AMF

If oil odor is found at the outlet before the standards (a) or (b) shown above are satisfied, replace the element.

- When replacing the element, replace also the O-ring and gasket with new ones. For details about how to replace the O-ring and gasket, Refer to relevant pages that describe the replacement parts in detail.

■ Inspection items

- ① If the element reaches the replacement timing, immediately replace the element with a new one. If the element is used continuously without replacement, the element may be damaged.

- ② Be sure to discharge the drain accumulated in the filter container.

If the drain is not discharged, the accumulated drain flows to the outlet. When using the AFF2C to 22C, 37B, 75B, AM□150C to 550C, 650, or 850 with the drain cock, drain guide, or ball valve, discharge the drain before the drain level reaches the center of the sight glass. If the drain is not discharged, the drain flows to the outlet. Be sure to discharge the drain and check the discharge status while referring to the figure on the right.

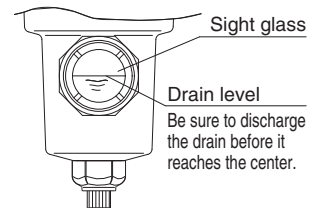

- ③ With auto drain

- This auto drain functions to discharge the drain when the drain level reaches the upper portion of the sight glass.
- For the AFF2C to 22C, 37B, AM□150C to 550C, and 650 with the auto drain, the drain is automatically discharged with the knob tightened to the "S" side during normal operation. Additionally, the drain can also be discharged manually.

<Manual operation procedure>

A manual knob is provided at the end of the auto drain. This knob is tightened to the "S" side during normal operation. When the knob is loosened to the "O" side, the drain can be discharged. (Note that the drain gushes from the drain port if the pressure remains inside the filter.)

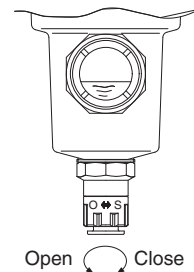

■ Probable troubles (Reference)

Refer to the "Troubleshooting". (P.243)

2 Troubleshooting

The following describes the general contents of the troubleshooting.

Trouble (Symptom)	Cause	Corrective action
The pressure drop is large.	The flow rate is excessive.	Use the equipment at a flow rate that is lower than the maximum flow rate diagram stated on the catalog or review the filter size.
	The element is used continuously even after its service life has expired.	Replace the element.
Oily content or solid foreign object comes to the secondary side.	The flow rate is excessive.	Use the equipment at a flow rate that is lower than the maximum flow rate diagram stated on the catalog or review the filter size.
	The element is used continuously even after its service life has expired.	Replace the element.
	The drain discharge is faulty.	[Manual drain] Discharge the drain before it reaches the center of the sight glass. [Auto drain] Clean the inside or replace the auto drain.
	Oily content, such as grease flows out from the equipment installed on the secondary side of the filter.	Install the AM series at the end of the pipe.
	Ambient air is entangled. (When used for the air blow.)	Perform the air blow in a clean environment. The nozzle becomes negative pressure and the ambient air is entangled. This may cause oily content or solid foreign object to enter the blow air.
	The cleaning of the pipe on the secondary side is insufficient.	Clean the inside of the pipe on the secondary side.
The drain leaks outside.	The seat is faulty.	① Check the O-ring for foreign object sticking ② Check the O-ring for kink, flaw, crack, or deterioration.
The drain leaks from the float type auto drain.	The seat is faulty (foreign object is sticking).	Clean the inside or replace the auto drain.
	The operation is faulty.	Clean the inside or replace the auto drain.
	The supply pressure is insufficient.	Check the air supply capability. N.O. type 0.1 MPa N.C. type 0.15 Mpa

Actuators

Modular F.R.L.
Pressure Control Equipment

Air Preparation
Equipment

Industrial Filters

Replacement
Procedure

Actuators

Modular F.R.L.
Pressure Control Equipment

Industrial Filters

Drain Separator for Vacuum

Series AMJ

Construction

AMJ3000, 4000

AMJ5000

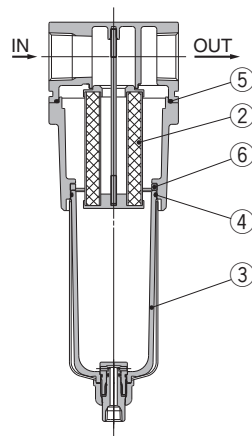
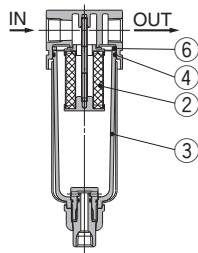

* The numbers are the same as the "Construction" of the Best Pneumatics No.4 Series AMJ.

Replacement Parts

No.	Description	Material	Part no.			Note
			AMJ3000	AMJ4000	AMJ5000	
2	Element assembly	—	AMJ-EL3000	AMJ-EL4000	AMJ-EL5000	
3	Bowl assembly <small>(Note)</small>	—	AMJ-CA30-□	AMJ-CA40-□	AMJ-CA40-□	
4	O-ring	NBR	C3SFP-260S	C4SFP-260S	C4SFP-260S	
5	O-ring	NBR	—	—	111710	
6	Spacer	NBR	AMJ-SA001	AMJ-SA002	AMJ-SA003	

Note) The spacer ⑥ is not included in the bowl assembly.

Maintenance

⚠ Caution

1. Replace the element when one of followings occurs.

- Pressure drop reaches 0.02 Mpa.
- Element operates for 2 years.

Element model number: AMJ-EL****

* **** is AMJ size symbol. (ex: AMJ-EL3000)

2. How to replace element assembly.

First, discharge the pressure in the case. (Make pressure 0 MPa)

- Remove case (housing).
- Replace element.
- Assemble case (housing).

* () for AMJ5000.

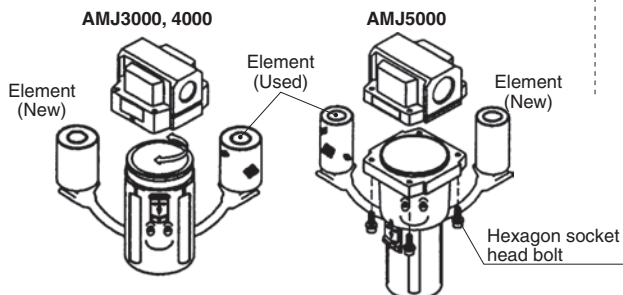

Water Separator

Series AMG

Construction

AMG150C to AMG550C, AMG650

AMG850

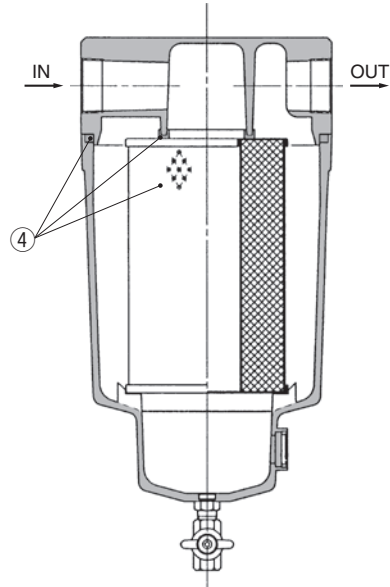
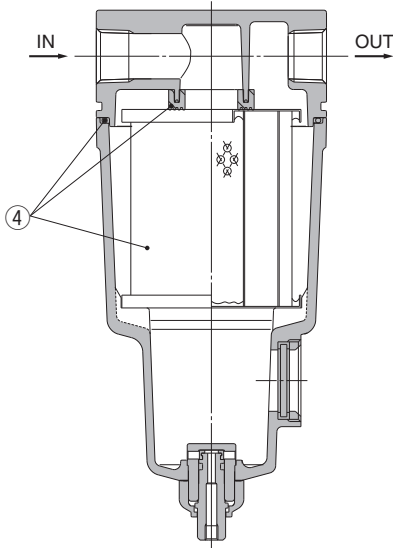

* The numbers are the same as the "Construction" of the Best Pneumatics No.5 Series AMG.

Replacement Parts

No.	Description*1	Material	Applicable model*2	Model						
				AMG150C	AMG250C	AMG350C	AMG450C	AMG550C	AMG650	AMG850
4	Element assembly	Resin,	Except option F	AMG-EL150	AMG-EL250	AMG-EL350	AMG-EL450	AMG-EL550	AMG-EL650	AMG-EL850
		others	For option F	AMG-EL150-F	AMG-EL250-F	AMG-EL350-F	AMG-EL450-F	AMG-EL550-F	—	—

*1) Element assembly: With gasket (1 pc.) and O-ring (1 pc.)

*2) F option, the rubber material: In the case of fluororubber

Maintenance

1.Element replacement

extremely dirty air might cause clogging due to deteriorated oil or rust. Replacement is necessary regularly. (When pressure drop reach 0.1MPa or replace element with new one when element has been used for 2 years.)

Element (gasket, O-ring accessory) model number:

AMG-EL***

*** is AMG size symbol. (Ex: AMG-EL150)

2.How to replace element assembly

First, discharge the pressure in the body. (Make pressure 0 MPa)

- Remove four hexagon socket head bolt.
- Replace element, gasket, O-ring.
- Tighten hexagon socket head bolt.

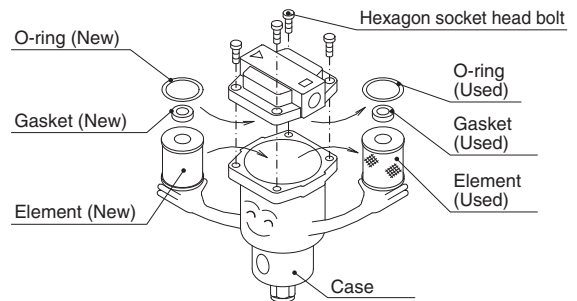

Actuators

Modular F.R.L.
Pressure Control Equipment

Air Preparation
Equipment

Industrial Filters

Replacement
Procedure

Actuators

Modular F.R.L.
Pressure Control Equipment

Industrial Filters

Series AFF

Construction

AFF2C to AFF22C, AFF37B

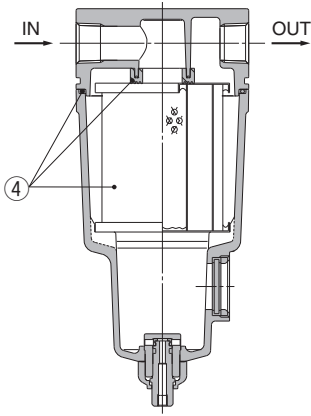

AFF75B

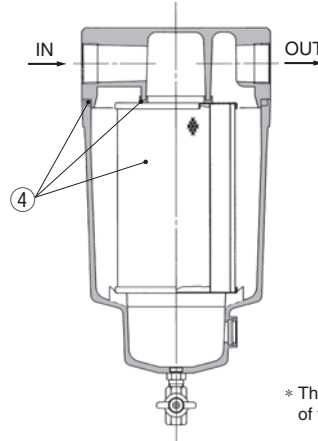

* The numbers are the same as the "Construction" of the Best Pneumatics No.5 Series AFF.

Replacement Parts

No.	Description*1	Material	Applicable model*2	Model						
				AFF2C	AFF4C	AFF8C	AFF11C	AFF22C	AFF37B	AFF75B
4	Element assembly	Cotton paper, others	Except option F	AFF-EL2B	AFF-EL4B	AFF-EL8B	AFF-EL11B	AFF-EL22B	AFF-EL37B	AFF-EL75B
			For option F	AFF-EL2B-F	AFF-EL4B-F	AFF-EL8B-F	AFF-EL11B-F	AFF-EL22B-F	—	—

*1) Element assembly: With gasket (1 pc.) and O-ring (1 pc.)

*2) F option, the rubber material: In the case of fluororubber

Maintenance

1. Replace the element when one of followings occurs.

- Pressure drop reaches 0.1 MPa.
 - Element operates for 2 years.
- Element assembly (gasket, O-ring accessory) model number: AFF-EL***

* *** is AFF size symbol. (ex.: AFF-EL2B)

2. How to replace element assembly

First, discharge the pressure in the body. (Make pressure 0 MPa.)

- Remove four hexagon socket head bolt.
- Replace element, gasket, O-ring.
- Tighten hexagon socket head bolt.

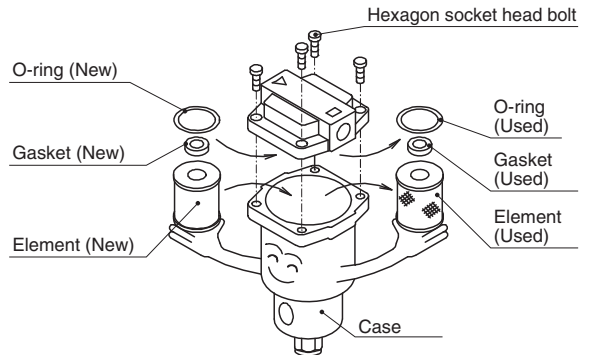

AFF75A to 220A

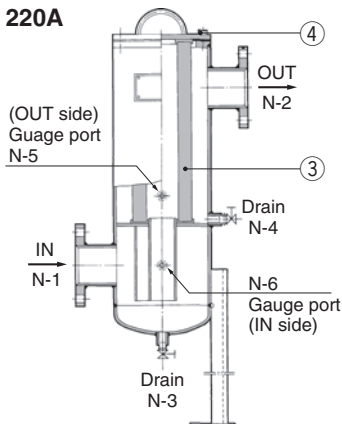

Replacement Parts

No.	Description	Material	Qty.	Model		
				AFF75A	AFF125A	AFF150A
3	Element	—	1	EC700-003N	EC800-003N	EC900-003N
4	Seal	NBR	1	AL-33S	AL-34S	AL-35S

Mist Separator

Series AM

Construction

AM150C to AM550C, AM650

AM850

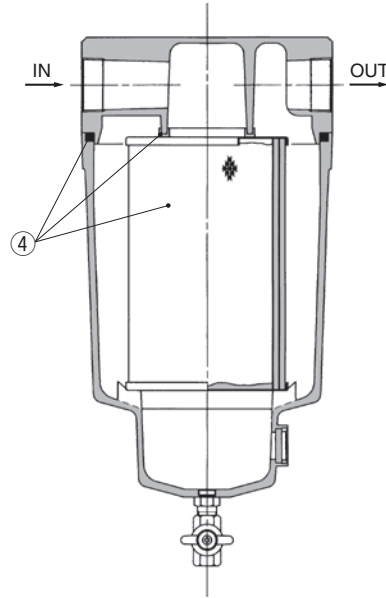
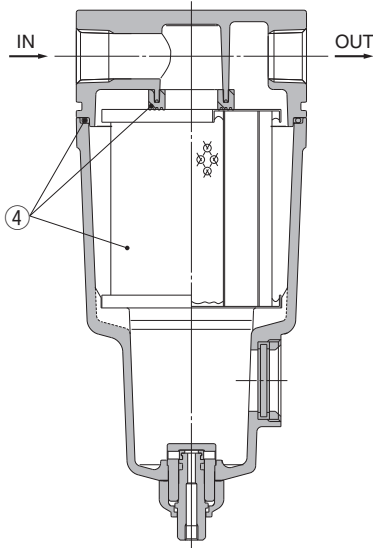

* The numbers are the same as the "Construction" of the Best Pneumatics No.5 Series AM.

Replacement Parts

No.	Description*1	Material	Applicable model*2	Model						
				AM150C	AM250C	AM350C	AM450C	AM550C	AM650	AM850
4	Element assembly	Glass fiber, others	Except option F For option F	AM-EL150	AM-EL250	AM-EL350	AM-EL450	AM-EL550	AM-EL650	AM-EL850
				AM-EL150-F	AM-EL250-F	AM-EL350-F	AM-EL450-F	AM-EL550-F	—	—

*1) Element assembly: With gasket (1 pc.) and O-ring (1 pc.)

*2) F option, the rubber material: In the case of fluororubber

Maintenance

1. Replace the element when one of followings occurs.

- Pressure drop reaches 0.1 MPa.
 - Element operates for 2 years.
- Element assembly (gasket, O-ring accessory) model number: AM-EL***

* *** is AM size symbol. (ex.: AM-EL150)

2. How to replace element assembly

- First, discharge the pressure in the body. (Make pressure 0 MPa.)
- Remove four hexagon socket head bolt.
 - Replace element, gasket, O-ring.
 - Tighten hexagon socket head bolt.

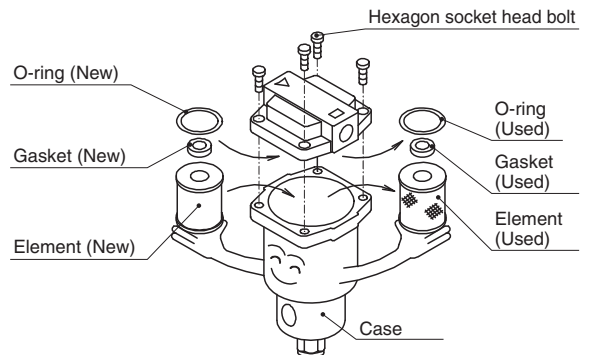

Actuators

Modular F.R.L.
Pressure Control Equipment

Air Preparation
Equipment

Industrial Filters

Replacement
Procedure

Actuators

Modular F.R.L.
Pressure Control Equipment

Industrial Filters

Series AMD

Construction

AMD150C to AMD550C, AMD650

AMD850

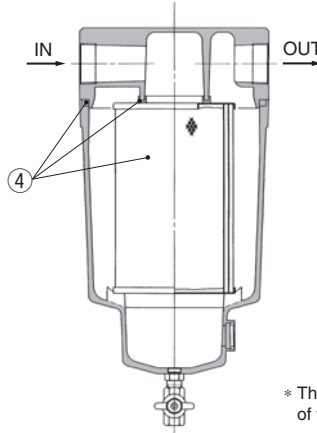
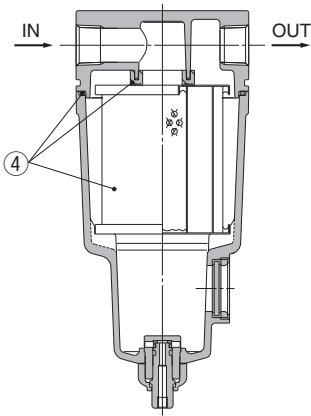

* The numbers are the same as the "Construction" of the Best Pneumatics No.5 Series AMD.

Replacement Parts

No.	Description*1	Material	Applicable model*2	Model						
				AMD150C	AMD250C	AMD350C	AMD450C	AMD550C	AMD650	AMD850
4	Element assembly	Glass fiber, others	Except option F For option F	AMD-EL150	AMD-EL250	AMD-EL350	AMD-EL450	AMD-EL550	AMD-EL650	AMD-EL850
				AMD-EL150-F	AMD-EL250-F	AMD-EL350-F	AMD-EL450-F	AMD-EL550-F	—	—

*1) Element assembly: With gasket (1 pc.) and O-ring (1 pc.)

*2) F option, the rubber material: In the case of fluororubber

Maintenance

1. Replace the element when one of followings occurs.

- Pressure drop reaches 0.1 MPa.
 - Element operates for 2 years.
- Element assembly (gasket, O-ring accessory) model number: AMD-EL***

* *** is AMD size symbol. (ex.: AMD-EL150)

2. How to replace element assembly

First, discharge the pressure in the body. (Make pressure 0 MPa.)

- Remove four hexagon socket head bolt.
- Replace element, gasket, O-ring.
- Tighten hexagon socket head bolt.

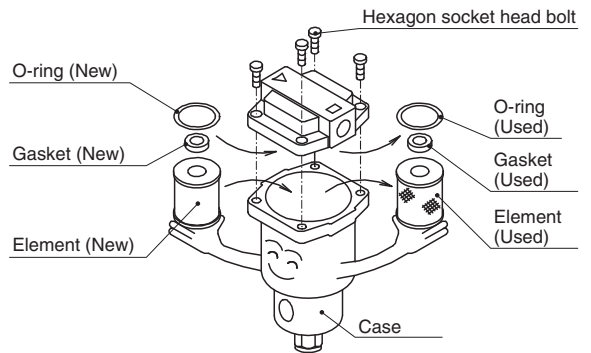

AMD80□, 81□, 90□, 9□1, 10□□

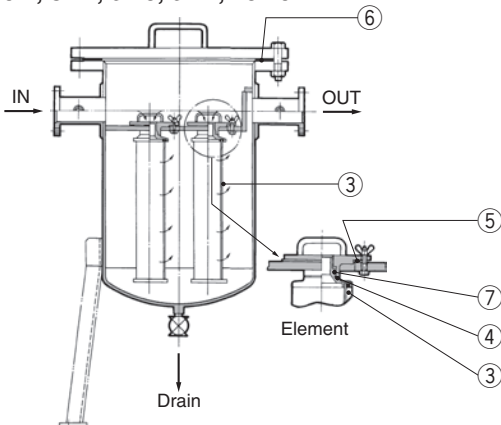

Replacement Parts

Model applicable filter	③ Element		④ Seal (Material: NBR)		⑤ Seal (Material: NBR)		⑥ Gasket (Material: V#6500)		⑦ O-ring (Material: NBR)		
	Kit no.	Qty.	Kit no.	Qty.	Kit no.	Qty.	Kit no.	Qty.	Kit no. (Nominal)	Qty.	
AMD800	63174	1	63148	1	OD112XID90XT3	1	AL-61S	1	KA00061 (1A-G35)	1	
AMD810					—	—	—				
AMD801					1	—	—	AL-60S			1
AMD811					—	—	—	—			—
AMD900					3	3	OD112XID90XT3	3			AL-63S
AMD910	3	3	3	—	—	AL-62S	1				
AMD911											
AMD1000											
AMD1010	5	5	OD112XID90XT3	5	AL-31S	1	5				

Micro Mist Separator with Pre-filter

Series AMH

Construction

AMH150C to AMH550C, AMH650

AMH850

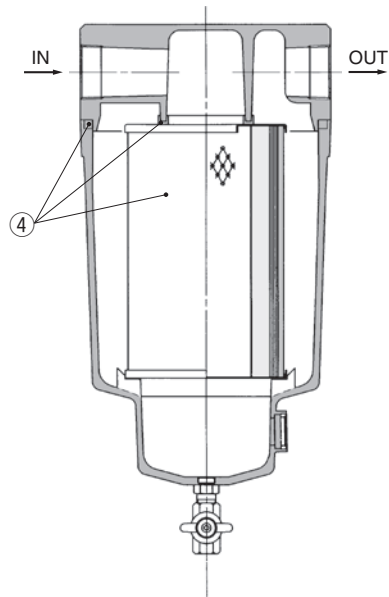
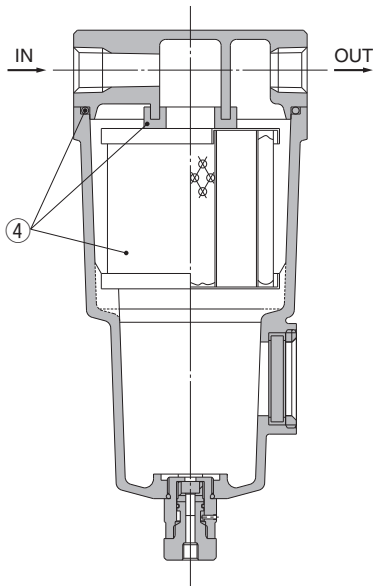

* The numbers are the same as the "Construction" of the Best Pneumatics No.5 Series AMH.

Replacement Parts

No.	Description*1	Material	Applicable model*2	Model						
				AMH150C	AMH250C	AMH350C	AMH450C	AMH550C	AMH650	AMH850
4	Element assembly	Glass fiber, others	Except option F For option F	AMH-EL150	AMH-EL250	AMH-EL350	AMH-EL450	AMH-EL550	AMH-EL650	AMH-EL850
				AMH-EL150-F	AMH-EL250-F	AMH-EL350-F	AMH-EL450-F	AMH-EL550-F	—	—

*1) Element assembly: With gasket (1 pc.) and O-ring (1 pc.)

*2) F option, the rubber material: In the case of fluororubber

Maintenance

1. Replace the element when one of followings occurs.

- Pressure drop reaches 0.1 MPa.
 - Element operates for 2 years.
- Element assembly (gasket, O-ring accessory) model number: AMH-EL***

* *** is AMH size symbol. (ex.: AMH-EL150)

2. How to replace element assembly

- First, discharge the pressure in the body. (Make pressure 0 MPa.)
- Remove four hexagon socket head bolt.
- Replace element, gasket, O-ring.
- Tighten hexagon socket head bolt.

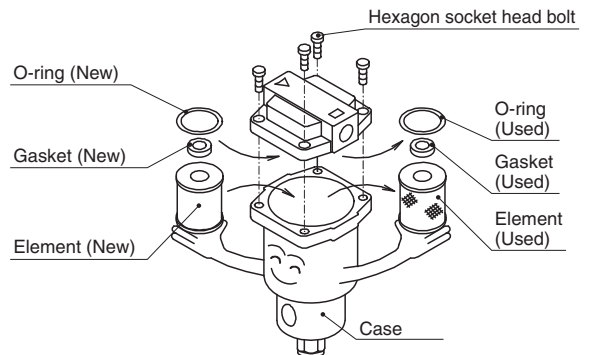

Actuators

Modular F.R.L.
Pressure Control Equipment

Air Preparation
Equipment

Industrial Filters

Replacement
Procedure

Actuators

Modular F.R.L.
Pressure Control Equipment

Industrial Filters

Super Mist Separator

Series AME

Construction

AME150C to AME550C

AME650, AME850

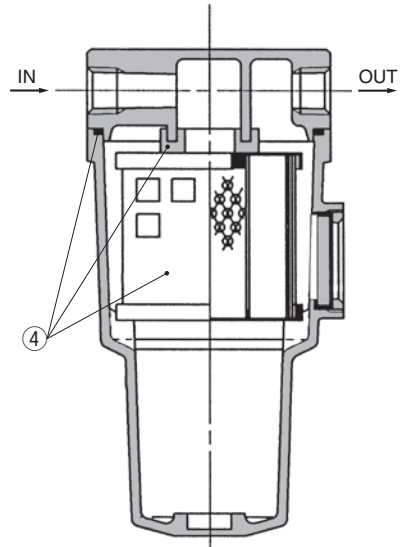
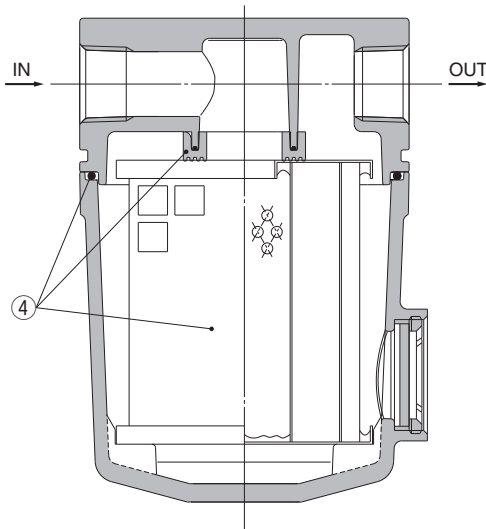

* The numbers are the same as the "Construction" of the Best Pneumatics No.5 Series AME.

Replacement Parts

No.	Description*1	Material	Applicable model*2	Model						
				AME150C	AME250C	AME350C	AME450C	AME550C	AME650	AME850
4	Element assembly	Glass fiber,	Except option F	AME-EL150	AME-EL250	AME-EL350	AME-EL450	AME-EL550	AME-EL650	AME-EL850
		others	For option F	AME-EL150-F	AME-EL250-F	AME-EL350-F	AME-EL450-F	AME-EL550-F	—	—

*1) Element assembly: With gasket (1 pc.) and O-ring (1 pc.)

*2) F option, the rubber material: In the case of fluororubber

Maintenance

1. Replace the element when one of followings occurs.

- Red spots appear on the element surface.
 - Operated for 2 years, or pressure drop reaches 0.1 MPa.
- Element assembly (gasket, O-ring accessory) model number: AME-EL***

* *** is AME size symbol. (ex.: AME-EL150)

2. How to replace element assembly

First, discharge the pressure in the body. (Make pressure 0 MPa.)

- Remove four hexagon socket head bolt.
- Replace element, gasket, O-ring.
- Tighten hexagon socket head bolt.

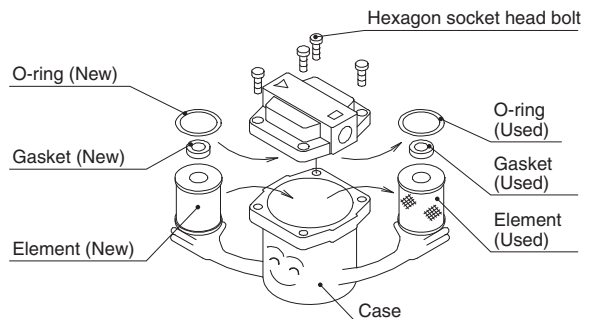

Odor Removal Filter

Series AMF

Construction

AMF150C to AMF550C

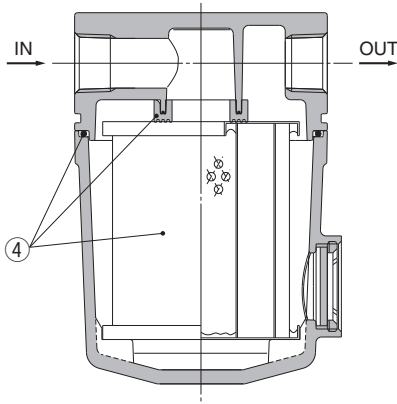

AMF650, AMF850

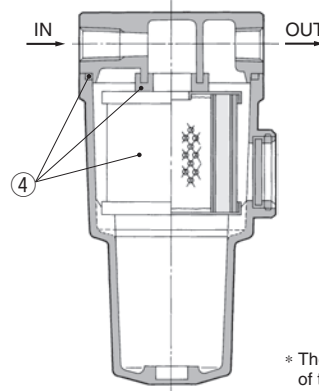

* The numbers are the same as the "Construction" of the Best Pneumatics No.5 Series AMF.

Replacement Parts

No.	Description*1	Material	Applicable model*2	Model						
				AMF150C	AMF250C	AMF350C	AMF450C	AMF550C	AMF650	AMF850
4	Element assembly	Glass fiber, others	Except option F For option F	AMF-EL150 AMF-EL150-F	AMF-EL250 AMF-EL250-F	AMF-EL350 AMF-EL350-F	AMF-EL450 AMF-EL450-F	AMF-EL550 AMF-EL550-F	AMF-EL650	AMF-EL850

*1) Element assembly: With gasket (1 pc.) and O-ring (1 pc.)

*2) F option, the rubber material: In the case of fluororubber

Maintenance

1. Element replacement

Since element life depend on odour concentration of compressed air, it can not be specified. Confirm deodorizing capacity remaining period, and replace the element periodically afterwards. However, replace element with new one when element has been used for 2 years, or when pressure drop reaches 0.1 MPa.

Element assembly (gasket, O-ring accessory) model number: AMF-EL***

* *** is AMF size symbol. (ex.: AMF-EL150)

2. How to replace element assembly

First, discharge the pressure in the body. (Make pressure 0 MPa.)

- Remove four hexagon socket head bolt.
- Replace element, gasket, O-ring.
- Tighten hexagon socket head bolt.

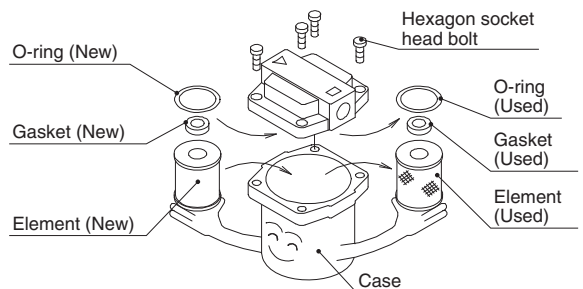

AMF80□, 90□, 1000

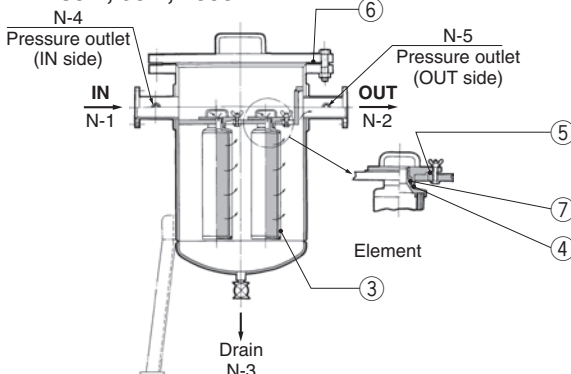

Replacement Parts

Model applicable filter	③ Element		④ Seal (Material: NBR)		⑤ Seal (Material: NBR)		⑥ Gasket (Material: V#6500)		⑦ O-ring (Material: NBR)	
	Kit no.	Qty.	Kit no.	Qty.	Kit no.	Qty.	Kit no.	Qty.	Kit no. (Nominal)	Qty.
AMF800		1		1	OD112XID90XT3	1	AL-61S	1		1
AMF801		1		1	—	—	AL-60S	1		1
AMF900	63271	3	63148	3	OD112XID90XT3	3	AL-63S	1	KA00061	3
AMF901		3		3	—	—	AL-62S	1	1A-G35	3
AMF1000		5		5	OD112XID90XT3	5	AL-31S	1		5

Industrial Filters

1 Indication of replacement of elements, inspection items

■ Replacement standards

<Element replacement>

The differential pressure (pressure drop) between the primary side and secondary side reaches 0.1 MPa. Additionally, even if any differential pressure does not occur, replace the element once every two years.

■ Inspection items

Check each seal part for leak periodically.

Check the pressure/temperature periodically to make sure that the filter is within its operable range.

If the differential pressure reaches 0.1 MPa during operation, stop the operation and replace the element with a new one.

Remove the dust accumulated in the bowl periodically.

How to Select Element Order Number for Replacement



POINT

The element number for replacement is written on the nameplate.



Element number for replacement
Order the element no. written in here.

* If the information written on the nameplate cannot be confirmed, please specify the element number as described below.

Order Example

* Element number for FGGSB-20-B002NA

A

Check the product number of the industrial filter. Confirm the items written on the right.

① Element length

* The element length is the total length of combined short elements.

② Element category

③ Nominal filtration accuracy

④ Element seal material

How to Order

FGG S B - 20 - B 002 N A -

Material	
Symbol	Body / O-ring
S	Stainless steel 304 / NBR
L	Stainless steel 304 / FKM

1

Symbol	Element length
B	L500 (L250 x 2)
C	L750 (L250 x 3)
D	L1000 (L250 x 4)

Port size	
Symbol	Port size Rc
20	2

2

Element category		
Symbol	Element type	Material
B	Bronze	Bronze
S	Sintered metal	Stainless steel
T	Fiber	Polypropylene
G	(Honeycomb)	Glass fiber
H		Cotton
P	Paper	Cotton
M	Micromesh	Stainless steel 304/Epoxy
L		Stainless steel 316

Option

Symbol	Pressure gauge type
Nil	None (with plug)
G1	G46-10-02M (Brass at wetted parts)
G2	G46-10-02X3 (Stainless steel at wetted parts)

* Please use the applicable pressure gauge depending on the fluid used.

Element seal material ^{Note 1)}

Symbol	Element seal material
A ^{Note 2)}	Non-asbestos
T	Fluororesin
N	NBR
V	FKM

4

Note 1) Not used with fiber elements.

Note 2) Not possible with bronze elements.

Nominal filtration accuracy (μm)

Symbol	Nominal filtration accuracy (μm)
X50	0.5
001	1
002	2
005	5
010	10
020	20
040	40
050	50
070	70
074	74
075	75
100	100
105	105
120	120

3

Note) For a comparison with the nominal filtration accuracy according to the element category, refer to pages 256 and 257.

B

Select the Number and Size of Elements

* Please select accordingly from the following two selection types of numbers and sizes.

Specifications

5

Model		FGGSB ^{Note 1)}		FGGSC ^{Note 1)}		FGGSD ^{Note 1)}		FGGLB ^{Note 1)}		FGGLC ^{Note 1)}		FGGLD ^{Note 1)}	
Number of elements		7 ^{Note 2)} / 14		7 ^{Note 2)} / 21		7 ^{Note 2)} / 28		7 ^{Note 2)} / 14		7 ^{Note 2)} / 21		7 ^{Note 2)} / 28	
Element size		ø65 x L500 / ø65 x L250		ø65 x L750 / ø65 x L250		ø65 x L1000 / ø65 x L250		ø65 x L500 / ø65 x L250		ø65 x L750 / ø65 x L250		ø65 x L1000 / ø65 x L250	
Main materials	Cover	Stainless steel 304											
	Case	Stainless steel 304											
	O-ring	NBR						FKM					
	Legs	SS400 (Chromatic plating)											

Note 1) Cannot be used with gases.

Note 2) In the case of a sintered metal element or paper element.

There are various types of elements for replacement.
 Select respective element type according to the type of industrial filter you are using.

C Element Model Determination

Specify the element type by filling out the element number with the respective codes of the items selected in sections **A** and **B**.

* **As for the number of orders, specify it by item ⑤, “number of elements”, in section B.**
 The number of orders is 7 in this example.

How to Order Standard Elements

Model Determination → **E B 200 - 002 N**

Element symbol •

Element material •

Symbol	Element material
A - 2	Bronze
B	Stainless steel 316

Element seal material/Operating temperature range •

Symbol	Element seal material	Operating temperature range(°C)
A (Note)	Non-asbestos	0 to 150
T	Fluororesin	0 to 120
N	NBR	0 to 80
V	FKM	0 to 120

Note) Not possible with bronze elements.

Element size •

Symbol	Element size
A - 1	ø65 x L250
B - 5	ø65 x L500
	ø65 x L750
	ø65 x L1000

Nominal filtration accuracy (µm) •

Symbol	Nominal filtration accuracy (µm)
001	1
A - 3	002
	005
	010
	020
	040
	070
	100
	120

Actuators

Modular F.R.L.
Pressure Control Equipment

Air Preparation
Equipment

Industrial Filters

Replacement
Procedure

Actuators

Modular F.R.L.
Pressure Control Equipment

Industrial Filters

Elements Sintered Metal/Fiber

Sintered Metal Filter Elements

- Outstanding mechanical strength, heat resistance and chemical resistance.
- Formed by sintering finely powdered metal, so a high filtration accuracy can be obtained.
- Even if clogging progresses, the element can be reused by cleaning.
- Main applications

Ideal as a check filter for keeping fluid clean. All types of gases, fluids, general solvents and high-temperature fluids



⚠ Caution

Bronze element, but may have been discolored by moisture in the atmosphere, the characteristics are not affected.

Specifications

Material	Bronze	Stainless steel 316
Operating temperature (C°) ^{Note 2)}	0 to 150	0 to 150
Nominal filtration accuracy (μm)	1, 2, 5, 10, 20, 40, 70, 100, 120	
Max. differential pressure resistance	0.7 MPa	
Element replacement differential pressure	0.1 MPa	
Chemical resistance	Acid	Cannot be used.
	Alkali	Can be used depending on conditions.
Element category of How to Order	B	S

Note 1) Cannot be used with hydrochloric acid, hydrofluoric acid or phosphoric acid.

Note 2) Varies depending on the seal material used.

How to Order Standard Elements

E B 200 - 005 N

Element symbol

Element material

Symbol	Element material
B	Bronze
S	Stainless steel 316

Element size

Symbol	Element size
100	ø65 x L250
200	ø65 x L500
300	ø65 x L750
400	ø65 x L1000

Nominal filtration accuracy (μm)

Symbol	Nominal filtration accuracy (μm)
001	1
002	2
005	5
010	10
020	20
040	40
070	70
100	100
120	120

Element seal material/Operating temperature range

Symbol	Element seal material	Operating temperature range(C°)
A ^{Note)}	Non-asbestos	0 to 150
T	Fluororesin	0 to 120
N	NBR	0 to 80
V	FKM	0 to 120

Note) Not possible with bronze elements.

Replacement Seal

Symbol	part no.	Quantity
A	AL-7S	2
T	AL-6S	
N	AL-8S	
V	AL-9S	

Fiber Elements

- Four types of materials with different characteristics are available so the filters are applicable to any application.
- Elements are economical because particle capturing capacity is excellent, and element life is long.
- Elements are disposable so maintenance and replacement are easy.
- Main applications

Cotton	Cleaning water, General neutral fluids, General solvents, Dry air
Polypropylene	Plating fluids, General acids, Alkali fluids, Industrial water, Cooling water
Glass fiber	Acid fluids, High-temperature fluids



Specifications

Material	Core material	Operating temperature (°C)	Nominal filtration accuracy (μm)	Differential pressure resistance (Max.)	Element replacement differential pressure
Cotton	Stainless steel 304	-20 to 100	0.5, 1, 5, 10, 20, 50, 75, 100	0.2 MPa	0.1 MPa
Polypropylene	Polypropylene	0 to 60	0.5, 1, 5, 10, 20, 50, 75, 100		
Glass fiber	Stainless steel 316	0 to 400	1, 5, 10, 20		

Note) Size for all is ø65 x L250.

How to Order Standard Elements

Element material	Cotton	Polypropylene	Glass fiber
Core material	Stainless steel 304	Polypropylene	Stainless steel 316
Nominal filtration accuracy (μm)	0.5	EH10G	EHM10A
	1	EH39R10GV	EHM39R10AY
	5	EH23R10GV	EHM23R10AY
	10	EH19R10GV	EHM19R10AY
	20	EH15R10G	EHM15R10A
	50	EH11R10G	EHM11R10A
	75	EH10R10G	EHM10R10A
100	EH8R10G	EHM8R10A	—
Element category of How to Order	H	T	G

Standard Elements Paper/Micromesh

Paper Elements

- Cartridges are pleated for a large filtration area, and elements are economical due to their long service life.
- Main applications
Ideal for filtration of hydraulic oil, lubricating oil, fuel oil, oils for the liquid gas industry, dry inert gases, and dry air.

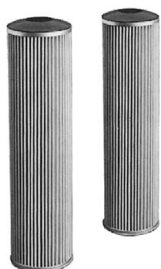

Specifications

Material	Filter paper (Cotton, Phenol resin impregnated paper)
Operating temperature (C°)	0 to 80
Nominal filtration accuracy (µm)	5, 10, 20
Max. differential pressure resistance	0.6 MPa
Adhesive used	Epoxy resin
Element replacement differential pressure	0.1 MPa
Element category of How to Order	P

How to Order Standard Elements

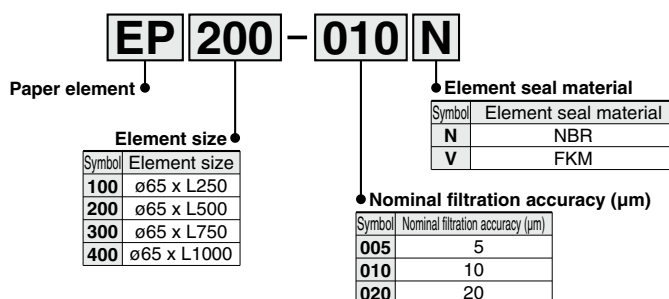

Micromesh Elements

- Stainless steel metal mesh has high filtration accuracy.
- Outstanding heat and chemical resistance. Applicable to a wide range of applications.
- Pleated type has 3 times the filtration area of a cylinder.
- Filters are economical because they can be cleaned and repeatedly used.
- Main applications
Please use 40 microns or less as a high-precision filter, and 74 microns or higher as a high-grade strainer. All types of gases and fluids, high-temperature fluids.

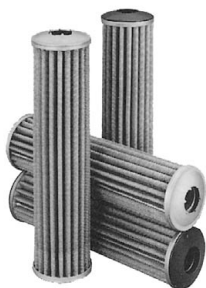

Specifications

Model	EM100	EM500
Materials	Stainless steel 304	Stainless steel 316
Jointing material	Epoxy resin	—
Operating temperature (C°) ^{Note 2)}	-5 to 100	-180 to 300
Nominal filtration accuracy (µm)	5, 10, 20, 40, 74, 105	
Max. differential pressure resistance	0.7 MPa	
Element replacement differential pressure	0.1 MPa	
Chemical resistance	Acid	Cannot be used.
	Alkali	Can be used.
Element category of How to Order	M	L

Note 1) Cannot be used with hydrochloric acid, hydrofluoric acid or phosphoric acid.

Note 2) Varies depending on the seal material used.

How to Order Standard Elements

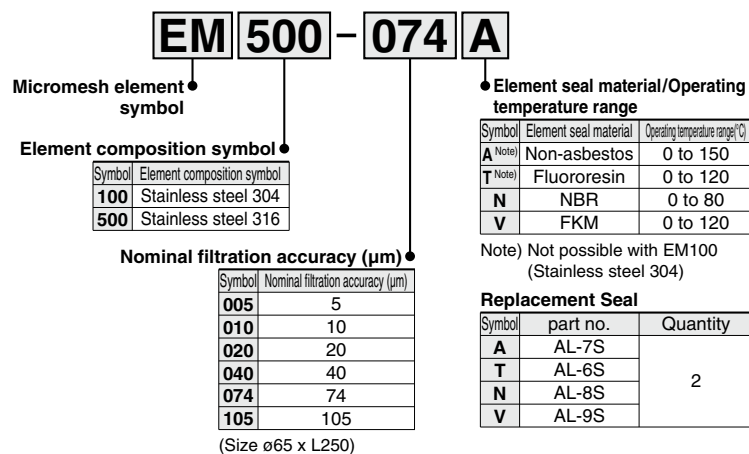

Series FGD 1



Replacement Parts and Seal List

How to Order

FGD **C** **A** - **03** - **B** **002** **N** - **B**

Element length

Symbol	Element length
A	L250
B	L500 (L250 x 2)

Port size

Symbol	Port size Rc
03	3/8
04	1/2
06	3/4

Element category

Symbol	Element type	Material
B	Sintered metal	Bronze
S		Stainless steel
T	Fiber (Honeycomb)	Polypropylene
G		Glass fiber
H		Cotton
P	Paper	Cotton
M	Micromesh	Stainless steel 304/Epoxy
L		Stainless steel 316

Material

Symbol	Cover	Case	Gasket/O-ring	Seal
C	Aluminum	SPCD	NBR	Nylon
E	Aluminum	SPCD	NBR	Nylon/Fluororesin
T	SCS14	Stainless steel 316	Fluororesin	Fluororesin
F	SCS14	Stainless steel 316	Fluororesin	Fluororesin (Antistatic specifications)

Made to Order

Symbol	Description
Nil	None
X77	With differential pressure indicator
X78	With differential pressure indication switch

Accessory

Symbol	Accessory
Nil	None
B	Bracket

Element seal material ^{Note 1)}

Symbol	Element seal material
A ^{Note 2)}	Non-asbestos
T	Fluororesin
N	NBR
V	FKM

Note 1) Not used with fiber elements.

Note 2) Not possible with bronze elements.

Nominal filtration accuracy (µm) ^{Notes)}

Symbol	Nominal filtration accuracy (µm)	Symbol	Nominal filtration accuracy (µm)
X50	0.5	050	50
001	1	070	70
002	2	074	74
005	5	075	75
010	10	100	100
020	20	105	105
040	40	120	120

Note) For a comparison with the nominal filtration accuracy according to the element category, refer to Best Pneumatics No.7.

Specifications

Model		FGDCA	FGDCB	FGDEA	FGDEB	FGDTA	FGDTB	FGDFA	FGDFB
Number of elements		1	2 ^{Note)}	1	2 ^{Note)}	1	2 ^{Note)}	1	2 ^{Note)}
Element size		ø65 x L250	ø65 x L500 (L250 x 2)	ø65 x L250	ø65 x L500 (L250 x 2)	ø65 x L250	ø65 x L500 (L250 x 2)	ø65 x L250	ø65 x L500 (L250 x 2)
Main materials	Cover	Aluminum		Aluminum		SCS14		SCS14	
	Case	SPCD		SPCD		Stainless steel 316		Stainless steel 316	
	Gasket/O-ring	NBR		NBR		Fluororesin		Fluororesin	
	Seal	Nylon		Nylon/Fluororesin		Fluororesin		Fluororesin	

Note) 1 element (ø65 x L500) in the case of a sintered metal element or paper element.

Series FGD ②

Replacement Procedure is p.460

Replacement Parts and Seal List

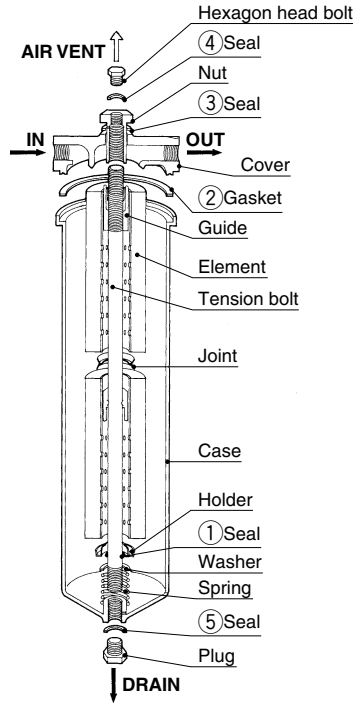

Replacement Parts

No.	Description	Material	Size
①	Seal	NBR JIS B 2401.P12	ø10 x t1
		Fluororesin	
②	Gasket	NBR	ø101 x t2
		Fluororesin	ø98 x t5
③	Seal ^{Note 3)}	Nylon	ø23 x t1
		Fluororesin	
		Fluororesin (Antistatic specifications)	
④	Seal	Nylon	ø10 x t1
		Fluororesin	
⑤	Seal	Nylon	ø20 x t1
		Fluororesin	

Note 1) The quantity used for 1 filter is 1 each for the following seals, gaskets and O-rings.

Note 2) Replacement seal kit part no.: KT-FGD□

For □, fill in the material symbol in "How to Order" (Refer to page 258).

A seal kit contains 1 each of seal/gasket No. 1 to 5.

Note 3) With antistatic specifications (FGDE, FGDF), this will be fluororesin (Antistatic specifications).

Seal Kit Number

Kit no.	Applicable model	Contents
KT-FGDC	FGDC□	Replacement parts A 1 kit for each of each one of seals ① to ⑤ and gasket.
KT-FGDE	FGDE□	
KT-FGDT	FGDT□	
KT-FGDF	FGDF□	

• Refer to pages 254 and 255 for selection.
• Refer to pages 256 and 257 for the replacement element type.

* Number is the same as the Replacement Seal List of the Best Pneumatics No.7 Series FGD.

Actuators
Modular F.R.L.
Pressure Control Equipment
Air Preparation Equipment
Industrial Filters
Replacement Procedure
Actuators
Modular F.R.L.
Pressure Control Equipment
Industrial Filters

Series FGE 1



Replacement Parts and Seal List

How to Order

FGES/FGEL type (V-band type) FGE **S** **A** - **10** - **B** **002** **N** **A** -

Material

Symbol	Body	Gasket/O-ring
S	Stainless steel 304	NBR
L		FKM

Option

Symbol	Pressure gauge type
Nil	None (with plug)
G1	G46-10-02M (Brass at wetted parts)
G2	G46-10-02X3 (Stainless steel at wetted parts)

* Please use the applicable pressure gauge depending on the fluid used.

FGET type (Bolt tightening type) FGE **T** **A** - **10** - **B** **002** **N**

Material

Symbol	Body	Gasket/O-ring
T	Stainless steel 304	Fluororesin

Element length

Symbol	Element length
A	L250
B	L500 (L250 x 2)
C	L750 (L250 x 3)

Port size

Symbol	Port size R
10	1
20	2

Element seal material ^{Note 1)}

Symbol	Element seal material
A ^{Note 2)}	Non-asbestos
T	Fluororesin
N	NBR
V	FKM

Note 1) Not used with fiber elements.
Note 2) Not possible with bronze elements.

Nominal filtration accuracy (µm) ^{Note)}

Symbol	Nominal filtration accuracy (µm)	Symbol	Nominal filtration accuracy (µm)
X50	0.5	050	50
001	1	070	70
002	2	074	74
005	5	075	75
010	10	100	100
020	20	105	105
040	40	120	120

Note) For a comparison with the nominal filtration accuracy according to the element category, refer to Best Pneumatics No.7.

Element category

Symbol	Element type	Material
B	Sintered metal	Bronze
S		Stainless steel
T	Fiber	Polypropylene
G		Glass fiber
H		Cotton
P		Cotton
M	Micromesh	Stainless steel 304/Epoxy
L		Stainless steel 316

Specifications

Model	FGESA ^{Note 1)}	FGESB ^{Note 1)}	FGESC ^{Note 1)}	FGELA ^{Note 1)}	FGELB ^{Note 1)}	FGELC ^{Note 1)}	FGETA	FGETB	FGETC					
Number of elements	4	4 ^{Note 2)}	8	4 ^{Note 2)}	12	4	4	4 ^{Note 2)}	8	4 ^{Note 2)}	12			
Element size	ø65 to 70 x L250	ø65 to 70 x L500	ø65 to 70 x L250	ø65 to 70 x L750	ø65 to 70 x L250	ø65 to 70 x L500	ø65 to 70 x L250	ø65 to 70 x L750	ø65 to 70 x L250	ø65 x L250	ø65 x L500	ø65 x L250	ø65 x L750	ø65 x L250
Main materials	Cover	Stainless steel 304												
	Case	Stainless steel 304												
	Gasket	—	—	—	—	—	—	Fluororesin	Fluororesin	Fluororesin	—			
	O-ring	NBR					FKM					—		
	Legs	SS400 (Chromatic plating)												

Note 1) Cannot be used with gases.

Note 2) In the case of a sintered metal element or paper element.

Series FGE ②

Replacement Procedure is P.461, 463

Replacement Parts and Seal List

FGES/FGEL type (V-band type)

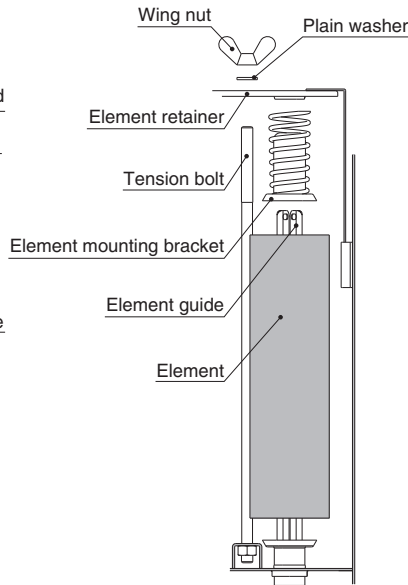
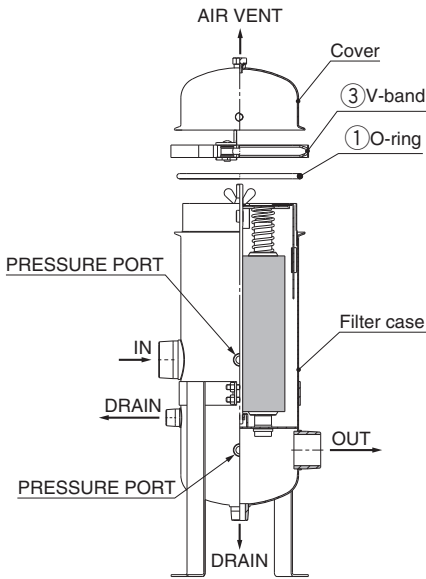

FGET type (Bolt tightening type)

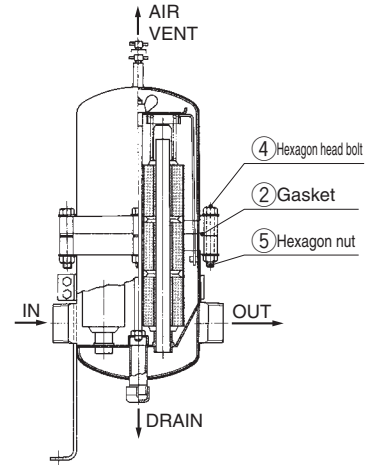

Replacement Part

Applicable filter	① O-ring Kit no. (Nominal)	② Gasket Kit no.	③ V-band Kit no. (Nominal)	④ Hexagon head bolt Kit no. (Nominal)	⑤ Hexagon nut Kit no. (Nominal)
FGES	KA00822 (1A-P185)	—	FGE-BA001	—	—
FGEL	KA00711 (4D-P185)	—		—	—
FGET	—	AL-19S	—	CB00021 (M12 x 1.75 x L95)	DA00110 (M12 x 1.75)

Note) The quantity used for 1 filter is 1 each of the above O-ring and gasket etc. Four hexagonal bolts are used for 1 filter.

- Refer to pages 254 and 255 for selection.
- Refer to pages 256 and 257 for the replacement element type.

* Number is the same as the Replacement Seal List of the Best Pneumatics No.7 Series FGE.

Actuators

Modular F.R.L.
Pressure Control Equipment

Air Preparation
Equipment

Industrial Filters

Replacement
Procedure

Actuators

Modular F.R.L.
Pressure Control Equipment

Industrial Filters

Series **FGG** ①



Replacement Parts and Seal List

How to Order

FGG **S** **B** - **20** - **B** **002** **N** **A** -

Material

Symbol	Body	O-ring
S	Stainless steel 304	NBR
L	Stainless steel 304	FKM

Element length

Symbol	Element length
B	L500 (L250 x 2)
C	L750 (L250 x 3)
D	L1000 (L250 x 4)

Port size

Symbol	Port size Rc
20	2

Element category

Symbol	Element type	Material
B	Sintered metal	Bronze
S		Stainless steel
T	Fiber	Polypropylene
G		Glass fiber
H	Paper	Cotton
P		Cotton
M	Micromesh	Stainless steel 304/Epoxy
L		Stainless steel 316

Option

Symbol	Pressure gauge type
Nil	None (with plug)
G1	G46-10-02M (Brass at wetted parts)
G2	G46-10-02X3 (Stainless steel at wetted parts)

* Please use the applicable pressure gauge depending on the fluid used.

Element seal material ^{Note 1)}

Symbol	Element seal material
A ^{Note 2)}	Non-asbestos
T	Fluororesin
N	NBR
V	FKM

Note 1) Not used with fiber elements.

Note 2) Not possible with bronze elements.

Nominal filtration accuracy (µm) ^{Note)}

Symbol	Nominal filtration accuracy (µm)	Symbol	Nominal filtration accuracy (µm)
X50	0.5	050	50
001	1	070	70
002	2	074	74
005	5	075	75
010	10	100	100
020	20	105	105
040	40	120	120

Note) For a comparison with the nominal filtration accuracy according to the element category, refer to Best Pneumatics No.7.

Specifications

Model		FGGSB ^{Note 1)}		FGGSC ^{Note 1)}		FGGSD ^{Note 1)}		FGGLB ^{Note 1)}		FGGLC ^{Note 1)}		FGGLD ^{Note 1)}	
Number of elements		7 ^{Note2)}	14	7 ^{Note2)}	21	7 ^{Note2)}	28	7 ^{Note2)}	14	7 ^{Note2)}	21	7 ^{Note2)}	28
Element size		ø65 x L500	ø65 x L250	ø65 x L750	ø65 x L250	ø65 x L1000	ø65 x L250	ø65 x L500	ø65 x L250	ø65 x L750	ø65 x L250	ø65 x L1000	ø65 x L250
Main materials	Cover	Stainless steel 304											
	Case	Stainless steel 304											
	O-ring	NBR						FKM					
	Legs	SS400 (Chromatic plating)											

Note 1) Cannot be used with gases.

Note 2) In the case of a sintered metal element or paper element.

Replacement Parts and Seal List

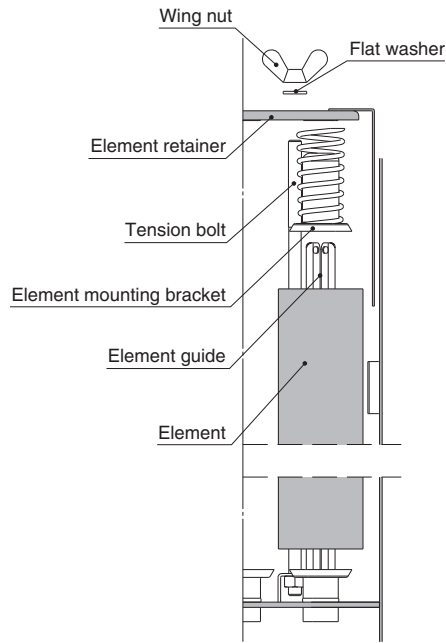
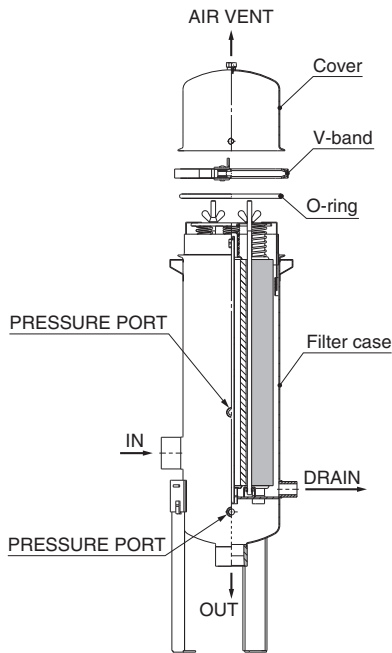

Replacement Parts

No.	Description	Material	
		FGGS	FGGL
1	O-ring	NBR (Part no.: AL-25S)	FKM (Part no.: AL-22S)
—	Case fastening parts	V-band coupling (Part no.: CY-27S)	

Note) The quantity used for 1 filter is 1 each of the above O-ring etc.

- Refer to pages 254 and 255 for selection.
- Refer to pages 256 and 257 for the replacement element type.

* Number is the same as the Replacement Seal List of the Best Pneumatics No.7 Series FG.

Actuators

Modular F.R.L.
Pressure Control Equipment

Air Preparation
Equipment

Industrial Filters

Replacement
Procedure

Actuators

Modular F.R.L.
Pressure Control Equipment

Industrial Filters

Series FGA



Replacement Parts and Seal List

How to Order

FGA C 04 A - 10 - B 002 N

Vessel material (wetted parts)

Symbol	Vessel material (wetted parts)
C	SS400
S	Stainless steel 304

Number of arranged elements

Symbol	Number of arranged elements	Symbol	Number of arranged elements
04	4	29	29
07	7	34	34
09	9	37	37
18	18	53	53
22	22	83	83

Element length

Symbol	Element length
A	L250
B	L500 (L250 x 2)
C	L750 (L250 x 3)
D	L1000 (L250 x 4)

Element seal material Note 1)

Symbol	Element seal material
A <small>Note 2)</small>	Non-asbestos
T	Fluororesin
N	NBR
V	FKM

Note 1) Not used with fiber elements.
Note 2) Not possible with bronze elements.

Nominal filtration accuracy (μm) Note)

Symbol	Nominal filtration accuracy (μm)	Symbol	Nominal filtration accuracy (μm)
X50	0.5	050	50
001	1	070	70
002	2	074	74
005	5	075	75
010	10	100	100
020	20	105	105
040	40	120	120

Note) For a comparison with the nominal filtration accuracy according to the element category, refer to Best Pneumatics No.7.

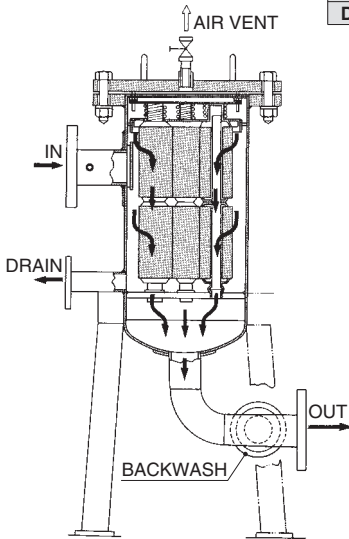

Port size

Symbol	Port size
10	25 (1 ^B)
14	40 (1 1/2 ^B)
20	50 (2 ^B)
24	65 (2 1/2 ^B)
30	80 (3 ^B)
40	100 (4 ^B)
60	150 (6 ^B)

Note) The connection method is JIS 10KFF flange connection.

Element category

Symbol	Element type	Material
B	Sintered metal	Bronze
S		Stainless steel
T	Fiber	Polypropylene
G		Glass fiber
H		Cotton
P	Paper	Cotton
M	Micromesh	Stainless steel 304/Epoxy
L		Stainless steel 316

Applicable Element Specifications

Description	Material	Nominal filtration accuracy (μm)	Size
Sintered metal	Bronze	1, 2, 5, 10, 20, 40, 70, 100, 120	ø65 x L250 ø65 x L500 ø65 x L750 ø65 x L1000
	Stainless steel 316		
Paper	Cotton (Phenol)	5, 10, 20	ø65 x L250 ø65 x L500 ø65 x L750 ø65 x L1000
Fiber	Cotton	0.5, 1, 5, 10, 20, 50, 75, 100	ø65 x L250
	Polypropylene		
	Glass fiber		
Micromesh	Stainless steel 304	5, 10, 20, 40, 74, 105	ø65 x L250
	Stainless steel 316		



Element mounting figure

Refer to pages 256 and 257 for the replacement element type.

* Number is the same as the Replacement Seal List of the Best Pneumatics No.7 Series FGA.

Series FGB

Replacement Procedure is P.472

Replacement Parts and Seal List

How to Order

FGB C 04 A - 10 - B 002 N

Vessel material (wetted parts)

Symbol	Vessel material (wetted parts)
C	SS400
S	Stainless steel 304

Number of arranged elements

Symbol	Number of arranged elements	Symbol	Number of arranged elements
04	4	30	30
07	7	36	36
13	13	55	55
19	19	83	83

Element length

Symbol	Element length
A	L250
B	L500 (L250 x 2)
C	L750 (L250 x 3)
D	L1000 (L250 x 4)

Port size

Symbol	Port size
10	25 (1 ^B)
14	40 (1 1/2 ^B)
20	50 (2 ^B)
24	65 (2 1/2 ^B)
30	80 (3 ^B)
40	100 (4 ^B)
60	150 (6 ^B)

Note) The connection method is JIS 10KFF flange connection.

Element seal material Note 1)

Symbol	Element seal material
A <small>Note 2)</small>	Non-asbestos
T	Fluororesin
N	NBR
V	FKM

Note 1) Not used with fiber elements.

Note 2) Not possible with bronze elements.

Nominal filtration accuracy (μm) Note)

Symbol	Nominal filtration accuracy (μm)	Symbol	Nominal filtration accuracy (μm)
X50	0.5	050	50
001	1	070	70
002	2	074	74
005	5	075	75
010	10	100	100
020	20	105	105
040	40	120	120

Note) For a comparison with the nominal filtration accuracy according to the element category, refer to Best Pneumatics No.7.

Element category

Symbol	Element type	Material
B	Sintered metal	Bronze
S		Stainless steel
T	Fiber	Polypropylene
G		Glass fiber
H		Cotton
P	Paper	Cotton
M	Micromesh	Stainless steel 304/Epoxy
L		Stainless steel 316

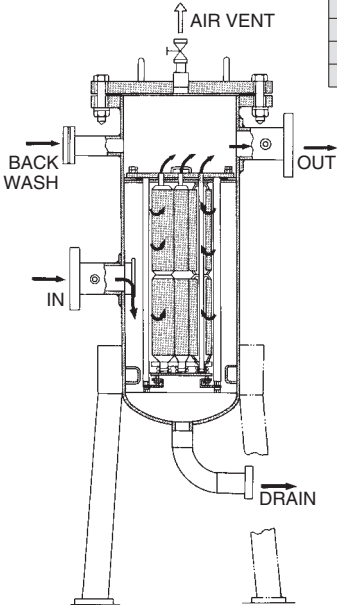

Element mounting figure

Applicable Element Specifications

Description	Material	Nominal filtration accuracy (μm)	Size
Sintered metal	Bronze	1, 2, 5, 10, 20, 40, 70, 100, 120	ø65 x L250 ø65 x L500 ø65 x L750 ø65 x L1000
	Stainless steel 316		
Paper	Cotton (Phenol)	5, 10, 20	ø65 x L250 ø65 x L500 ø65 x L750 ø65 x L1000
Fiber	Cotton	0.5, 1, 5, 10, 20, 50, 75, 100	ø65 x L250
	Polypropylene		
	Glass fiber		
Micromesh	Stainless steel 304	5, 10, 20, 40, 74, 105	ø65 x L250
	Stainless steel 316		

Refer to pages 256 and 257 for the replacement element type.

* Number is the same as the Replacement Seal List of the Best Pneumatics No.7 Series FGB.

Series FGC



Replacement Parts and Seal List

How to Order

FGC 1 C A - 04 - B 002 N

• **Maximum operating pressure**

Symbol	Maximum operating pressure
1	1 MPa
2	2 MPa
4	4 MPa

• **Vessel material (wetted parts)**

Symbol	Vessel material (wetted parts)
C	SGP
S	Stainless steel 304

• **Element length**

Symbol	Element length
A	L250
B	L500 (L250 x 2)

• **Port size**

Symbol	Port size
04	15 (1/2 ^B)
06	20 (3/4 ^B)
10	25 (1 ^B)

Note) The connection method is flange connection, as indicated below.
 FGC1: JIS 10KFF flange connection
 FGC2: JPI300^{Lp}RF flange connection
 FGC4: JPI600^{Lp}RF flange connection

• **Element seal material** ^{Note 1)}

Symbol	Element seal material
A ^{Note 2)}	Non-asbestos
T	Fluororesin
N	NBR
V	FKM

Note 1) Not used with fiber elements.
 Note 2) Not possible with bronze elements.

• **Nominal filtration accuracy (μm)** ^{Note)}

Symbol	Nominal filtration accuracy (μm)	Symbol	Nominal filtration accuracy (μm)
X50	0.5	050	50
001	1	070	70
002	2	074	74
005	5	075	75
010	10	100	100
020	20	105	105
040	40	120	120

Note) For a comparison with the nominal filtration accuracy according to the element category, refer to Best Pneumatics No.7.

• **Element category**

Symbol	Element type	Material
B	Sintered metal	Bronze
S		Stainless steel
T	Fiber	Polypropylene
G		Glass fiber
H		Cotton
P	Paper	Cotton
M	Micromesh	Stainless steel 316/Epoxy
L		Stainless steel 316

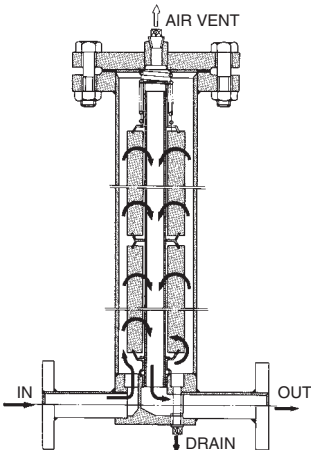

Element mounting figure

Applicable Element Specifications

Description	Material	Nominal filtration accuracy (μm)	Size
Sintered metal	Bronze	1, 2, 5, 10, 20, 40	ø65 x L250
	Stainless steel 316	70, 100, 120	ø65 x L500
Paper	Cotton (Phenol)	5, 10, 20	ø65 x L250 ø65 x L500
Fiber	Cotton	0.5, 1, 5, 10, 20	ø65 x L250
	Polypropylene	50, 75, 100	
	Glass fiber	1, 5, 10, 20	
Micromesh	Stainless steel 304	5, 10, 20, 40	ø65 x L250
	Stainless steel 316	74, 105	

• Refer to pages 256 and 257 for the replacement element type.

* Number is the same as the Replacement Seal List of the Best Pneumatics No.7 Series FGC.

Series FGF 1

Replacement Procedure is p.478

Replacement Parts and Seal List

How to Order

One element included FGF S 1 A - 20 - E 005 B - [] D

Three, five elements included FGF S 3 A - 40 - E 005 [] D

Bag filter • Material •

Symbol	Vessel material	Seal material	Applicable model		
			FGF□1	FGF□3	FGF□5
S	Stainless steel	NBR	●	●	●
C	Carbon steel		—	—	—
L	Stainless steel	FKM	●	●	●
R	Carbon steel		—	●	●

Number of elements •

Symbol	Number of elements
1	1 pc included (FGF□1)
3	3 pcs included (FGF□3)
5	5 pcs included (FGF□5)

Element size •

Symbol	Element size
A	ø190 x L440
B	ø190 x L770

Option •

Symbol	Option*	Applicable model		
		FGF□1	FGF□3	FGF□5
Nil	None	●	●	●
D	Davit for hanging an element	●	●	●
F	Companion flange	—	●	●
L	Foundation bolt (3 pcs)	●	●	●

* In the case of multiple options, indicate symbols in alphabetical order.

Pressure gauge

Symbol	Pressure gauge
Nil	Without pressure gauge (with plug)
G	With pressure gauge (1 MPa. Brass for wetted parts)

Element material (Polyester)

Symbol	Port size	Applicable model
20	Rc2	FGF□1
40	4 ^B JIS10 ^B FF	FGF□3
60	6 ^B JIS10 ^B FF	FGF□5

Port size

Symbol	Nominal filtration accuracy (Note)
005	5
010	10
025	25
050	50
100	100

Note) Nominal filtration accuracy refers to the filtration accuracy according to SMC criteria, and serves as a guideline for the particulates that can be filtered out. It does not mean that 100% of the particulates of the diameter shown can be filtered out.

Part number of element for replacement



EJ 501S - 005

• Element symbol

• Element size

Symbol	Element size	Applicable model
501S	ø190 x L440	For FGF□□A
601S	ø190 x L770	For FGF□□B

Specifications

Model		FGF□1A-20	FGF□1B-20	FGF□3A-40	FGF□3B-40	FGF□5A-60	FGF□5B-60
Element	Material	Polyester					
	Nominal filtration accuracy	5, 10, 25, 50, 100 µm					
	Element replacement differential pressure	Differential pressure 0.1 MPa					
	Number of elements	1 element included		3 elements included		5 elements included	
	Size	ø190 x L440	ø190 x L770	ø190 x L440	ø190 x L770	ø190 x L440	ø190 x L770
	Filtration area	1800 cm ²	3400 cm ²	5400 cm ²	10200 cm ²	9000 cm ²	17000 cm ²

Series FGF ②

Replacement Procedure is p.478

Replacement Parts and Seal List

FGF□1

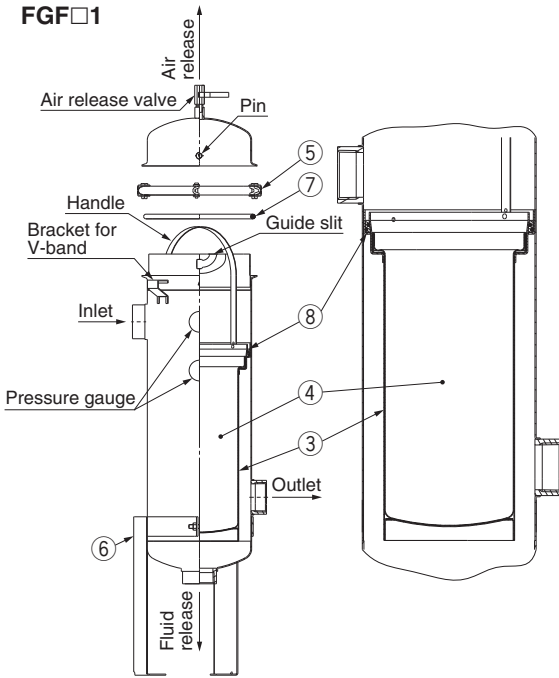

Replacement Parts

No.	Description	Part No.	Material	Qty.	Applicable model ^{Note)}
3	Basket	FGF-BT01	Stainless steel 304	1	FGF□1A
		FGF-BT02		1	FGF□1B
4	Element	EJ501S-□	Polyester	1	FGF□1A
		EJ601S-□		1	FGF□1B
5	V-band	FGF-BA01	Stainless steel	1	FGF□1□
6	Legs assembly (with bolt, nut, flat washer)	FGF-OP01 (Set)	Carbon steel	1	FGF□1□
7	O-ring	FGF-KT01	NBR	1	FGFS1□
		FGF-KT02	FKM	1	FGFL1□
8	Holder assembly (with O-ring)	FGF-KT03 (Set)	Polypropylene/NBR	1	FGFS1□
		FGF-KT04 (Set)	Polypropylene/FKM	1	FGFL1□

Note) Refer to "How to Order" on page 267 for the □ part of the model number.

Part number of element for replacement

EJ 501S - 005



● Element symbol

● Element size

Symbol	Element size	Applicable model
501S	φ190 x L440	For FGF□□A
601S	φ190 x L770	For FGF□□B

● Nominal filtration accuracy^{Note)}

Symbol	Nominal filtration accuracy (μm)
005	5
010	10
025	25
050	50
100	100

Note) Nominal filtration accuracy refers to the filtration accuracy according to SMC criteria, and serves as a guideline for the particulates that can be filtered out. It does not mean that 100% of the particulates of the diameter shown can be filtered out.

FGF□3□-40 FGF□5□-60

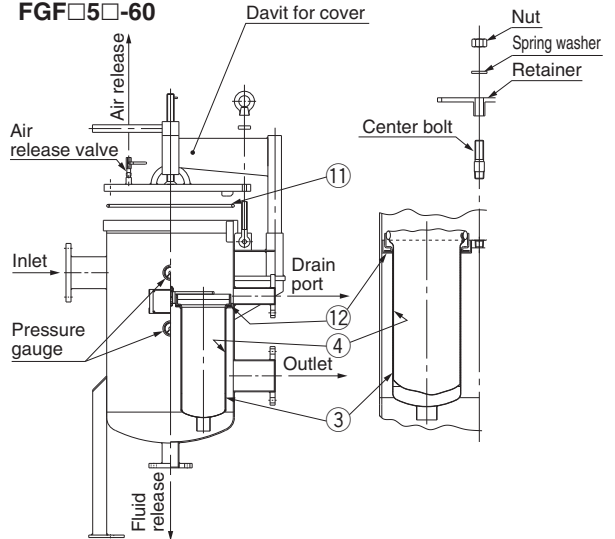

Replacement Parts

No.	Description	Part No.	Material	Qty.	Applicable model ^{Note)}
3	Basket	BT-3S	Stainless steel 304	3	FGF□3A-40
				5	FGF□5A-60
		BT-4S	Stainless steel 304	3	FGF□3B-40
				5	FGF□5B-60
4	Element	Refer to "How to Order".	Polyester	3	FGF□3□-40
				5	FGF□5□-60
11	O-ring	AL-26S	NBR	1	FGFS3□-40
				1	FGFC5□-60
		AL-27S	FKM	1	FGFL3□-40
				1	FGFR3□-40
12	Gasket	AL-23S	FKM	1	FGFL5□-60
				1	FGFR5□-60
		AL-24S	NBR	3	FGFS3□-40
				5	FGFC3□-40
AL-20S	NBR	5	FGFS5□-60		
		5	FGFC5□-60		
	AL-21S	FKM	3	FGFL3□-40	
			5	FGFR3□-40	
AL-21S	FKM	3	FGFL5□-60		
		5	FGFR5□-60		

Note) Refer to "How to Order" on page 267 for the □ part of the model number.

* Number is the same as the Replacement Seal List of the Best Pneumatics No.7 Series FGF.

Series FGH ①

Replacement Procedure is P.480

Replacement Parts and Seal List

How to Order

FGH 100 - 03 - J002T

High precision filter for liquids

Body size

Symbol	Element length	Applicable element
100	L117	EJ701S
200	L246	EJ801S, ED801S
300	L496	EJ901S, ED901S

* The membrane element cannot be selected for FGH100.

Port size

03	Rc3/8
04	Rc1/2
06	Rc3/4
10	Rc1

Built-in elements

Symbol	Filtration accuracy	Filtration efficiency	Element classification	Applicable body
J002T	2 μm		HEPO II Series EJ	FGH100 FGH200 FGH300
J004T	4 μm	99%		
J006T	6 μm			
J013T	13 μm		Membrane Series ED	FGH200 FGH300
DX20T	0.2 μm	99.9%		
DX40T	0.4 μm			

* Refer to Best Pneumatics No.7 for details about specifications, models, dimensions, etc. regarding the elements.

* When ordering only a vessel, it is not necessary to enter the symbol for built-in elements.

Specifications

Model	FGH100	FGH200	FGH300
Number of built-in elements (element length) (mm)	1 (125)	1 (250)	1 (500)

Since this product uses PTFE for gasket material, a large torque is required to tighten a clamp ring. The FKM specification with the clamp ring tightening torque reduced is also available. If the fluid conforms to FKM, use this specification.

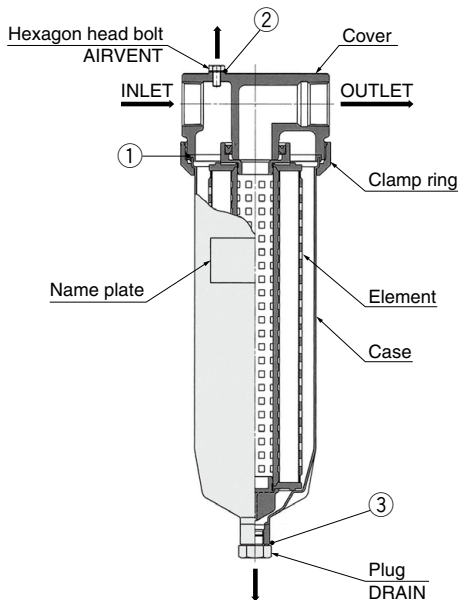

Replacement Parts

No.	Description	Part number		
		FGH100	FGH200	FGH300
1	Gasket	AL-58S#1		
2	Seal	AL-43S		
3	Seal	AL-53S		

* Use each one of the above parts for each filter unit.

* Use a commercially available belt wrench etc. for mounting and removing clamp rings.

• Refer to page 270 for the replacement element type.

* Number is the same as the Replacement Seal List of the Best Pneumatics No.7 Series FGH.

High Precision Filter for Liquids

Series *FGH* ②

Replacement
Procedure is
p.480

HEPO II Element for Series FGH Series *EJ*



Specifications

Model		EJ□S-002	EJ□S-004	EJ□S-006	EJ□S-013
Filtration accuracy(Filtration efficiency 99%)		2	4	6	13
Filtration area (cm ²)	Length	117 mm	1890	2310	2090
		246 mm	4250	5200	4700
		496 mm	8500	10400	9400
Heat resistant temperature (°C)		80			
Material	Filter media	Polyester			
	Reinforcement material	Polypropylene			
	Others	Polypropylene			
Pressure resistance		0.5 MPa at 20°C, 0.125 MPa at 80°C			

Note) See "How to Order" below for items represented by □.

How to Order Elements

EJ **701** **S** - **002** **T**

Element classification
EJ HEPO II

Element size symbol
701 For FGH100
801 For FGH200
901 For FGH300

Element seal
T PTFE

Filtration accuracy (Filtration efficiency 99%)
002 2 μm
004 4 μm
006 6 μm
013 13 μm

Membrane Element for Series FGH Series *ED*



Specifications

Model		ED□S-X20	ED□S-X40
Filtration accuracy(Filtration efficiency 99.9%) ^{Note 1)}		0.2	0.4
Filtration area (cm ²)	Length	247 mm	6,200
		495 mm	12,400
Heat resistant temperature (°C)		80	
Material	Filter media	Polyether sulfone	Cellulose acetate & polyester
	Reinforcement material	Polypropylene	Polyester
	Others	Polypropylene	Polypropylene
Pressure resistance		0.5 MPa at 20°C, 0.125 MPa at 80°C	
Resistivity recovery ^{Note 2)}		60 min at 10 L/m	—
Others		100 L/4000 cm ² Pure water cleaning	—

Note 1) Filtration accuracy: tested with ultrapure water, flow rate at ΔP = 0.01 MPa.

Note 2) Resistivity recovery: time taken to recover to 18 MΩ·cm with ultrapure water.

Note 3) See "How to Order" below for items represented by □.

How to Order Elements

ED **801** **S** - **X20** **T**

Element classification
ED Membrane

Element size symbol
801 For FGH200
901 For FGH300

Element seal
T PTFE

Filtration accuracy (Filtration efficiency 99.9%)
X20 0.2 μm
X40 0.4 μm

* Cannot be used for FGH100.

Series FQ1 1

RoHS

* When combined with sintered elements (bronze), it is no longer compliant with RoHS.

Replacement Procedure is P.482

Replacement Parts and Seal List

How to Order

FQ1 0 1 0 N - 04 - M005N - B

Model symbol (In-line filters)

Housing material

Symbol	Cover	Case
0	Stainless steel 304	Stainless steel 304

Element sealing method

1	Flat gasket (D.O.E)
---	---------------------

Element size

Symbol	Element size
0	L125
1	L250
2	L500 (L250 x 2)

Housing O-ring material

Symbol	Material
N	NBR
V	FKM

Made to order specifications

Nil	Note
X19	Without V-band support
X68	Chemical resistant type

* For other made to order specifications, refer to Best Pneumatics No.7.

Options

Nil	N/A
-B	Bracket

Element type

Select from tables below.

Port size

Symbol	Port size	Applicable model		
		FQ1010	FQ1011	FQ1012
04	Rc1/2	●	●	
06	Rc3/4	●	●	●
10	Rc1		●	●



FQ1010 □

FQ1011 □

FQ1012 □

Specifications

Model	FQ1010	FQ1011	FQ1012
No. of built-in elements (L : Element length in mm)	1 (L 125)	1 (L 250)	2 (L 250 x 2)

Element

1. Fiber element (P.P.)

Dimensions	Element symbol	Nominal filtration accuracy (µm)	Part number
ø65 x L250	TX50	0.5	EHM10A
	T001	1	EHM39R10AY
	T005	5	EHM23R10AY
	T010	10	EHM19R10AY
	T020	20	EHM15R10A
	T050	50	EHM11R10A
	T075	75	EHM10R10A
	T100	100	EHM8R10A

2. Fiber element (Cotton)

Dimensions	Element symbol	Nominal filtration accuracy (µm)	Part number
ø65 x L250	HX50	0.5	EH10G
	H001	1	EH39R10GV
	H005	5	EH23R10GV
	H010	10	EH19R10GV
	H020	20	EH15R10G
	H050	50	EH11R10G
	H075	75	EH10R10G
	H100	100	EH8R10G

3. Micromesh element (Stainless steel 304) Bonding material: Epoxy resin

Dimensions	Element symbol	Nominal filtration accuracy (µm)	Part number
ø65 x L250	M005 □	5	EM100-005 □
	M010 □	10	EM100-010 □
	M020 □	20	EM100-020 □
	M040 □	40	EM100-040 □
	M074 □	74	EM100-074 □
	M105 □	105	EM100-105 □
	ø65 x L125	M005 □	5
M010 □		10	EM200-010 □X4
M020 □		20	EM200-020 □X4
M040 □		40	EM200-040 □X4
M074 □		74	EM200-074 □X4
	M105 □	105	EM200-105 □X4

Note) Specify seal material in place of "□" (N for NBR or V for FKM).

4. Micromesh element (Stainless steel 316) Bonding material: TIG welding

Dimensions	Element symbol	Nominal filtration accuracy (µm)	Part number
ø65 x L250	L005 □	5	EM500-005 □
	L010 □	10	EM500-010 □
	L020 □	20	EM500-020 □
	L040 □	40	EM500-040 □
	L074 □	74	EM500-074 □
	L105 □	105	EM500-105 □
	ø65 x L125	L005 □	5
L010 □		10	EM600-010 □X4
L020 □		20	EM600-020 □X4
L040 □		40	EM600-040 □X4
L074 □		74	EM600-074 □X4
	L105 □	105	EM600-105 □X4

Note) Specify seal material in place of "□" (N for NBR or V for FKM).

* When combined with sintered elements (bronze), it is no longer compliant with RoHS.

Replacement Parts and Seal List

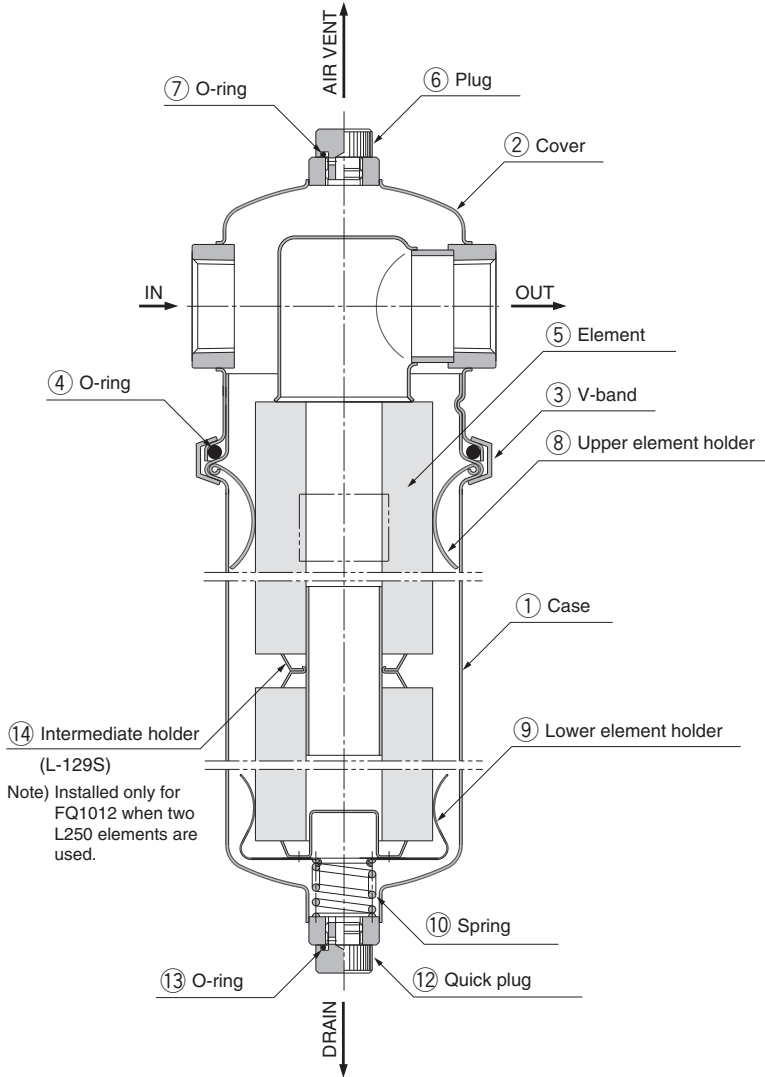

Replacement Parts

No.	Description	Part number	Material	Note
3	V band for replacement	FQ-BA001	Stainless steel 304	
4	O-ring	KT-FQ1-N	NBR	JIS B2401-1A-P85
7, 13	O-ring			JIS B2401-1A-P11
4	O-ring	KT-FQ1-V	FKM	JIS B2401-4D-P85
7, 13	O-ring			JIS B2401-4D-P11
6, 12	Quick plug	AG-9S	Stainless steel 303	
8	Upper element holder	L-131S	Stainless steel 304	
9	Lower element holder	L-135S	Stainless steel 304	
14	Intermediate holder	FQ-OP001	Stainless steel 304	
	Bracket	BP-13S	Stainless steel 304	For port size Rc 1
		BP-14S		For port size Rc 3/4
		BP-15S		For port size Rc 1/2

Series FN1/FN4 1

Replacement Procedure is p.483

Replacement Parts and Seal List

How to Order

With single element

FN1 1 0 1 N - 10 - S 020

With four elements

FN4 1 0 2 N - 20 - S 020

Housing material

Symbol	Housing material
1	Stainless steel 304

Element type (Note)

Symbol	Element type	Applicable model
0	Cylindrical type (5 µm, 20 µm)	FN1, FN4
1	Step type (5 µm)	FN1

Note) Refer to Best Pneumatics No.7 for detailed element type.

Element length

Symbol	Element length	Applicable model
1	L250 mm	FN1
2	L500 mm	FN1, FN4

Seal material

Symbol	Seal material
N	NBR
V	FKM

Pressure gauge

Symbol	Pressure gauge
Nil	None (With plug)
G <small>Note 1)</small>	With pressure gauge <small>Note 2)</small> (Wetted part: Brass)

Note 1) Contact SMC for the pressure gauge specification for stainless steel wetted parts.

Note 2) The FN4 series is equipped with two pressure gauges.

Element material

Symbol	Element material
S	Stainless steel 304

Nominal filtration rating

Symbol	Nominal filtration rating
005	5 µm (Cylindrical type, Step type)
020	20 µm (Cylindrical type)

Port size

Symbol	Port size	Applicable model
10	Rc1	FN1
20	Rc2	FN4

Specifications

Model		FN1101	FN1111	FN1102	FN1112	FN4102
Element dimension		ø65 x 250L			ø65 x 500L	
Element	Material	Stainless steel 304				
	Construction	Cylindrical type	Step type	Cylindrical type	Step type	Cylindrical type
	Nominal filtration rating	5 µm, 20 µm	5 µm	5 µm, 20 µm	5 µm	5 µm, 20 µm
	Differential pressure proof	0.6 MPa				

Actuators

Modular F.R.L.
Pressure Control Equipment

Air Preparation
Equipment

Industrial Filters

Replacement
Procedure

Actuators

Modular F.R.L.
Pressure Control Equipment

Industrial Filters

Series FN1/FN4 ②

Replacement Procedure is p.483

Replacement Parts and Seal List

FN11□1□-10-S□□□□

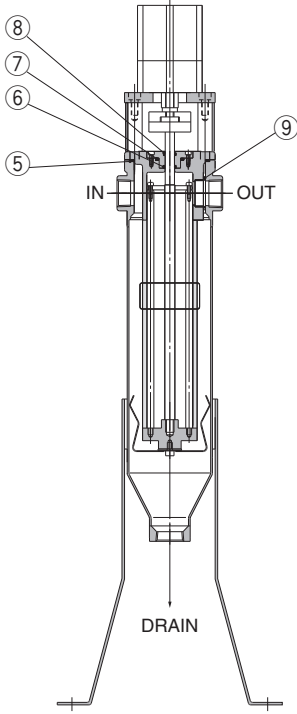

FN11□2□-10-S□□□□

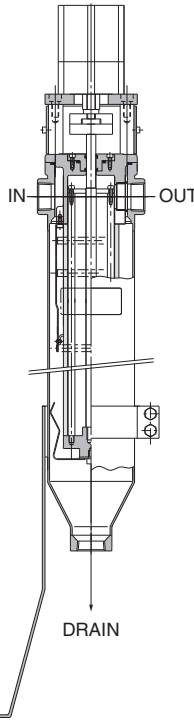

FN4102□-20-S□

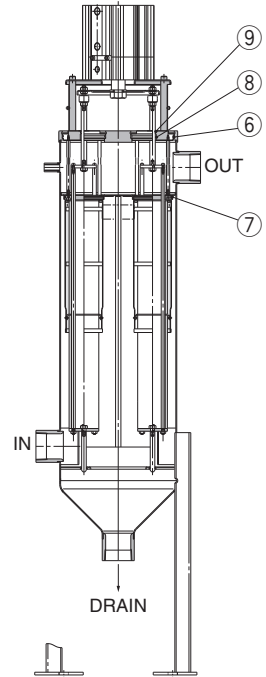

* Number is the same as the Replacement Seal List of the Best Pneumatics No.7 Series FN1/FN4.

Replacement Parts

No.	Description	Quantity	Material
⑤	O-ring	1	NBR or FPM
⑥	Penta seal	1	
⑦	O-ring	1	
⑧	Scraper	1	
⑨	O-ring	1	

Replacement Parts: Seal Kit

Model	Order no.	Material	Note
FN11□□N	KT-FN11N	NBR	Items ⑤ through ⑨ from the above chart, 1 pc. each
FN11□□V	KT-FN11V	FPM	

Replacement Element

Model	Order no.	Quantity	Note
FN11□1□	END100-005	1	5 μm, Cylindrical type
	END100-020	1	20 μm, Cylindrical type
	END110-005	1	5 μm, Step type
FN11□2□	END200-005	1	5 μm, Cylindrical type
	END200-020	1	20 μm, Cylindrical type
	END210-005	1	5 μm, Step type

Replacement Parts

No.	Description	Quantity	Material
⑥	O-ring	1	NBR or FPM
⑦	O-ring	1	
⑧	Penta seal	1	
⑨	Scraper	1	

Replacement Parts: Seal Kit

Model	Order no.	Material	Note
FN4102N	KT-FN41N	NBR	Items ⑥ through ⑨ from the above chart, 1 pc. each
FN4102V	KT-FN41V	FPM	

Replacement Element

Model	Order no.	Quantity	Note
FN4102□	END400-005	1	5 μm, Cylindrical type
	END400-020	1	20 μm, Cylindrical type

Series FN1/FN4 ③

Replacement Procedure is p.483

Options (Sold separately)

Reservoir tank: Series FNR

This tank is used to store sufficient fluid for back-flushing (For the FN1 series).

* Not required for the FN4, which has a built-in tank.

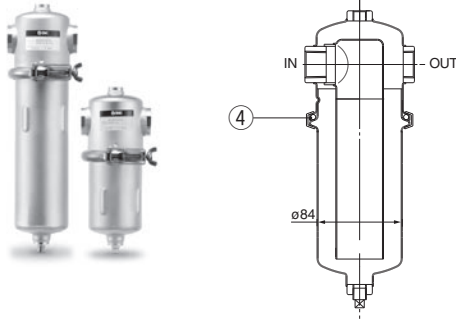

How to Order FNR10 0 N - 10

Symbol	Capacity	Applicable model
0	1.1L	FN11□1
1	1.8L	FN11□2

Size		Port size	
Symbol	Capacity	Symbol	Port size
0	1.1L	10	Rc1

Seal material	
Symbol	Material
N	NBR
V	FKM

Replacement Parts

No.	Description	Kit No.	Material	Quantity	Note
4	O-ring	KA00809	NBR	1	1A-P85
		KA00725	FKM	1	4D-P85

* O-ring standard: JIS B 2401

Specifications

Model	FNR100N-10	FNR100V-10	FNR101N-10	FNR101V-10
Tank capacity	1.1 L		1.8 L	
Port size	Rc1			
Material	Stainless steel 304			
Bowl & Cover				
O-ring	NBR	FKM	NBR	FKM
Weight	1.5 kg		1.9 kg	
Applicable filter	FN11□1□ (Element L 250)		FN11□2□ (Element L 500)	

Dust recovery filter (Produced upon receipt of order)

This filter is for recovering dust from fluid after element back-flushing. It enables re-use of the element (Gold mesh).

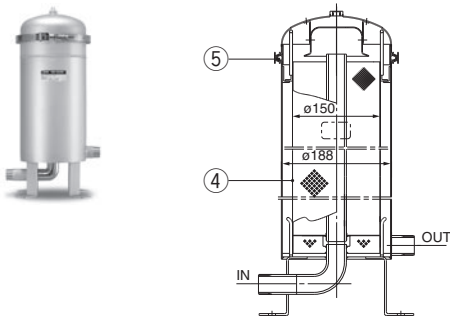

How to Order

FND100 N - 10 - M149 X0

Seal material		Nominal filtration rating	
Symbol	Material	Symbol	Nominal filtration rating
N	NBR	149	149 µm
V	FKM		

Element type	
Symbol	Type
M	Gold mesh

Port size	
Symbol	Port size
10	R1

Replacement Parts

No.	Description	Kit No.	Material	Quantity	Note
4	Element	EZH710AS-149	Stainless steel 304	1	
5	O-ring	KA00822	NBR	1	1A-P185
		KA00711	FKM	1	4D-P185

* O-ring standard: JIS B 2401

Specifications

Model	FND100N-10-M149X0	FND100V-10-M149X0
Port size	R1	
Bowl & Cover	Stainless steel 304	
Material	NBR	FKM
Element	Stainless steel 304	
Element nominal filtration rating	149 µm	
Weight	7.5 kg	

Note) Produced upon receipt of order.

Actuators

Replacement Procedure

CJP2	Pin Cylinder	P.278
CM2	Air Cylinder	P.280
CVM	Valve Mounted Cylinder	P.280
CG1	Air Cylinder	P.281
CG3	Air Cylinder Short Type	P.281
CG5-S	Stainless Steel Cylinder	P.281
MB	Air Cylinder	P.284
MB1	Square Tube Type Air Cylinder	P.284
CA2	Air Cylinder	P.284
CS1	Air Cylinder	P.287
CS2	Air Cylinder	P.287
CUJ	Mini Free Mount Cylinder	P.289
CQS	Compact Cylinder	P.290
CQ2	Compact Cylinder	P.290
RQ	Compact Cylinder with Air Cushion	P.290
CXT	Platform Cylinder	P.290
CVQ	Compact Cylinder With Solenoid Valve	P.290
HYQ	Hygienic Design Cylinder	P.297
HYC	Hygienic Design Cylinder	P.297
HYG	Hygienic Design Cylinder	P.301
MY1B	Mechanically Jointed Rodless Cylinder/Basic Type	P.304
MY1M	Mechanically Jointed Rodless Cylinder/Slide Bearing Guide Type	P.306
MY1C	Mechanically Jointed Rodless Cylinder/Cam Follower Guide Type	P.306
MY1□W	Mechanically Jointed Rodless Cylinder with Protective Cover	P.306
MY1H	Mechanically Jointed Rodless Cylinder/Linear Guide Type	P.310
MY2C	Mechanically Jointed Rodless Cylinder/Cam Follower Guide Type	P.311
MY2H/HT	Mechanically Jointed Rodless Cylinder/Linear Guide Type	P.311
MY3A	Mechanically Jointed Rodless Cylinders/Basic short type	P.312
MY3B	Mechanically Jointed Rodless Cylinders/Basic standard type	P.312
MY3M	Mechanically Jointed Rodless Cylinders/Slide bearing guide type	P.312
CY3B	Magnetically Coupled Rodless Cylinder/Basic Type	P.315
CY3R	Magnetically Coupled Rodless Cylinder/Direct Mount Type	P.316
REAR	Sine Rodless Cylinder	P.316
REBR	Sine Rodless Cylinder	P.316
CY1S	Magnetically Coupled Rodless Cylinder Slider Type/Slide Bearing	P.317
CY1L	Magnetically Coupled Rodless Cylinder Slider Type/Ball Bushing Bearing	P.318
MXS	Air Slide Table	P.319
MXQ	Air Slide Table	P.319
MXQR	Air Slide Table/Reversible Type	P.319
MXF	Low Profile Slide Table	P.324
MXW	Air Slide Table	P.325
MXP	Air Slide Table	P.326
MXY	Air Slide Table/Long Stroke Type	P.329
MGP	Compact Guide Cylinder	P.333

MGPW	Compact Guide Cylinder/Wide Type	P.333
MGQ	Compact Guide Cylinder	P.333
MGF	Guide Table	P.337
CXSJ/CXS/CXSW	Dual Rod Cylinder	P.339
CLG1	Fine Lock Cylinder	P.340
CL1	Lock-up Cylinder	P.343
CNG	Cylinder with Lock	P.348
MNB	Cylinder with Lock	P.351
CNA2	Cylinder with Lock	P.351
CNS	Cylinder with Lock	P.356
CLS	Cylinder with Lock	P.358
REAS	Sine Rodless Cylinder	P.361
REC	Sine Cylinder	P.362
RHC	High Power Cylinder	P.364
RZQ	3 Position Cylinder	P.367
MK	Rotary Clamp Cylinder/Standard	P.371
MK2T	Rotary Clamp Cylinder/Double Guide Type	P.371
CKQG/CKQP	Pin Clamp Cylinder	P.374
RSQ	Stopper Cylinder	P.385
RSG	Stopper Cylinder	P.385
RSH	Heavy Duty Stopper Cylinder	P.387
RS2H	Heavy Duty Stopper Cylinder	P.387
MIW/MIS	Escapements	P.390
CH□KD	JIS Standard Compact Hydraulic Cylinder	P.392
CH□KG	JIS Standard Compact Hydraulic Cylinder	P.393
CHN	Small Bore Hydraulic Cylinder	P.394
CHSD/CHSG	ISO Standard Hydraulic Cylinder	P.395
CH2□	JIS Standard Hydraulic Cylinder	P.396

Actuators

Modular F.R.L.
Pressure Control Equipment

Air Preparation
Equipment

Industrial Filters

Replacement
Procedure

Actuators

Modular F.R.L.
Pressure Control Equipment

Industrial Filters

Series CJP2 Replacement Procedure of Seal 1

⚠ Caution

Ask SMC for replacing a seal if a tube inside diameter is 4 mm.

Tubes with a 4 mm I.D cannot be disassembled. If they need to be disassembled in order to replace the packing or for other purposes, please contact an SMC representative for the repair.

1. Disassembly of the Cylinder

1-1. Cleaning

Prior to disassembly, wipe off any dirt from the outside of the actuator.

This will prevent the intrusion of dust and foreign materials during disassembly.

Take particular care on the surface of the piston rod.

1-2. Removal of retaining ring

Remove the retaining ring with proper pliers.

1-3. Removal of head cover

Remove the head cover from the body by pushing the piston rod to the head side.

1-4. Disassembly

Pull out the piston rod.

Take care not to scratch or mark the internal face of the body.

2. Removal of the Seal

2-1. Rod seal

Insert a watchmakers screw driver etc. from front the body and prise the seal out.

Take care not to scratch or score the seal groove in the body.

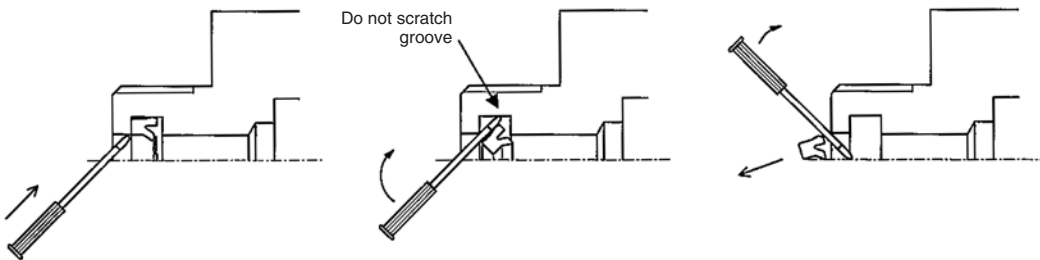

2-2. Piston seal

Push the tube gasket partially to make it come off and pull it out manually.

2-3. Gasket (See right)

Push the gasket partially to make it come off and pull it out manually.

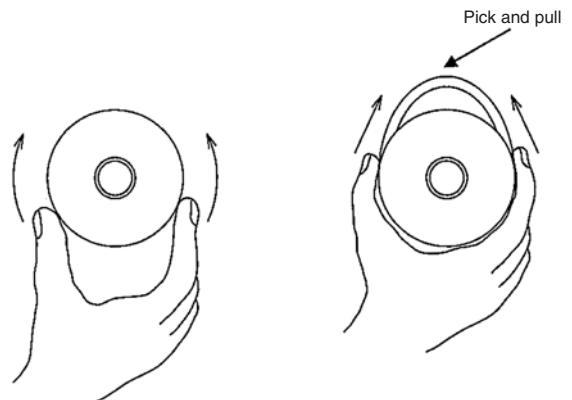

Series CJP2 Replacement Procedure of Seal 2

3. Application of Grease

3-1. Rod seal and Piston seal

Apply the grease evenly all around the new seal.

3-2. Gasket

Spread a thin film of grease over the tube gasket.

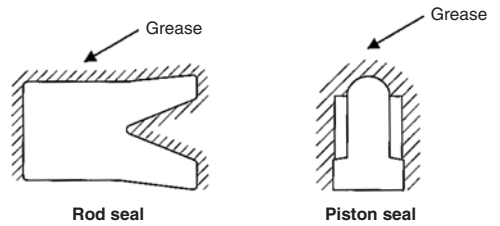

4. Mounting of Seal

4-1. Rod seal

Mount the rod seal with attention to direction.

Then, apply the grease on the rod seal and body bushing.

4-2. Piston seal

When mounting the seal, ensure there are no twists in the seal.

Also add the grease inside the groove.

4-3. Gasket

Pay attention not to make the gasket come off.

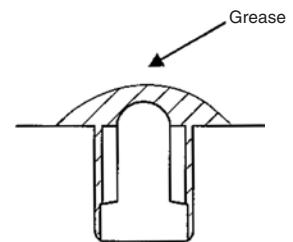
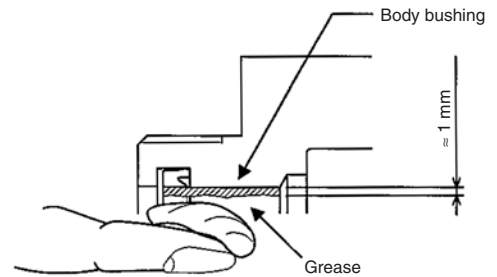

5. Application of Grease

5-1. Each component of the cylinder

Spread grease entirely over the parts shown.

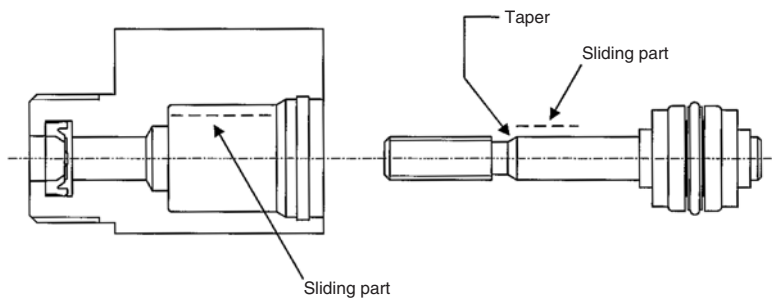

6. Reassembly of the Cylinder

6-1. Insertion of piston rod assembly

Please insert piston rod assembly in the body.

6-2. Insertion of head cover assembly

Please insert head cover assembly in the body.

6-3. Mounting of the retaining ring

Mount the retaining ring with proper pliers.

6-4. Check the assembly condition.

Confirm that there is no air leakage from the seal and that the cylinder can operate smoothly at a minimum operating pressure.

Series **CM2/CVM** Replacement Procedure of Seal 1

Caution

The cylinder of CM2/CVM series can not disassemble because the cover and the tube are connected by rolling caulking method.

1. How to Replace the Rod Seal

Replacement of the rod seal can be done even at the state of cylinder installed. As for replacement work, proceed as follows.

1-1. Demounting

When removing retaining ring by using a C-shaped retaining ring fitting tool for hole (snap ring pliers) and pulling out the piston rod at the state of rod cover port stopped up by finger, seal retainer and rod seal can be demounted.

1-2. Greasing

Use lithium soap base grease equivalent to JIS class 2.

Fulling lubricate by grease on inner-and-outer peripheries of new rod seals for replacement. Moreover, fill grease into groove and slot portions.

1-3. Mounting

Mounting the rod seal with paying attention as to direction. Slowly push the rod seal with slight rotation when letting the thread part of piston rod tip and width across flat part pass through and surely install to the rod cover housing.

Then, mount in the order of seal retainer and retaining ring.

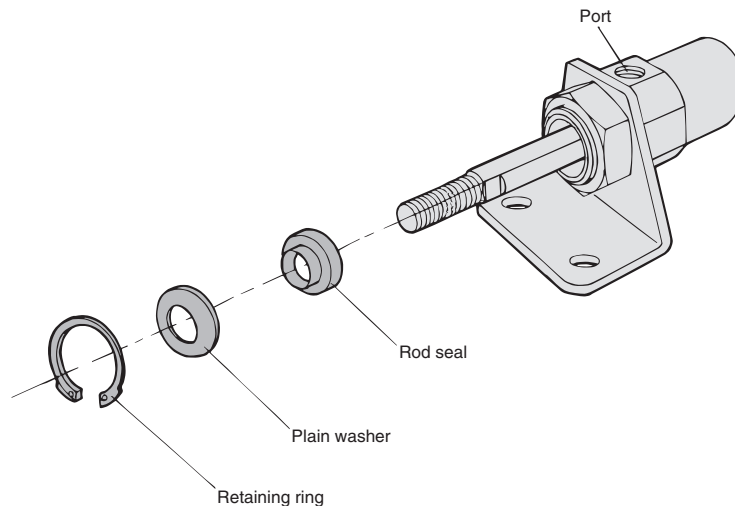

1. How to Replace the Seals

1-1. It is possible to replace the rod seal, piston seal, cylinder tube gasket for $\phi 20$ to $\phi 40$.

Series CBG1

For $\phi 20$ to $\phi 40$, it is possible to replace rod seal, piston seal, cylinder tube gasket and lock piston seal.

1-2. Contact SMC sales if it is necessary to replace seal for $\phi 50$ to $\phi 100$.

Series CBG1

For $\phi 50$ to $\phi 100$, it is possible to replace lock piston seal. For other seals, contact SMC.

1-3. Contact SMC sales if it is necessary to replace parts other than those mentioned above.

Warning

Only people who have sufficient knowledge and experience are allowed to replace seals.

The person who disassembles and reassembles the cylinder is responsible for the safety of the product.

Caution

When replacing seals, take care not to hurt your hand or finger on the corners of parts.

2. Disassembly/Reassembly

Caution

Disassemble and assemble the cylinder in a clean area. Perform on a clean cloth.

For disassembling, hold the flats of the tube cover gently in a vice and hold the flats of the rod cover with a spanner or monkey wrench to loosen and remove the rod cover. When reassembling, tighten 0 to 2 degrees more than the original position before disassembling.

Bore size of $\phi 50$ or more cannot be disassembled because they are tightened to a high torque.

Contact your SMC Sales representative if you need to disassemble these products.

For single-acting type, please be noted that the cover might pop up due to the internal spring.

Series CG5-S

The cover and cylinder tube are tighten with Loctite 542 as seal in order to prevent from leakage. Remove old loctite completely and put new loctite when reassemble cylinder.

3. Removal of the Seal

3-1. Rod seal

Insert a watchmakers screw driver from the front of the cover to pull out the seal as shown in Fig. 1.

Caution

Take care not to damage the seal groove of the cover at this time.

Series CG5-S

Whole rod cover assembly need to be changed when rod scraper of water resistant type is worn.

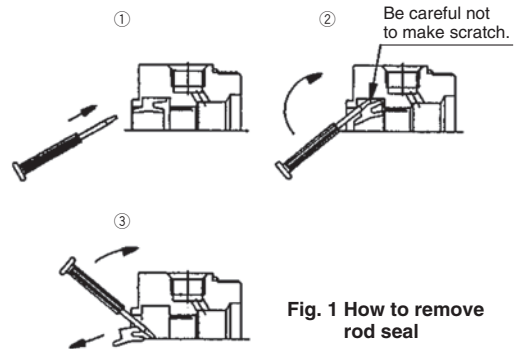

Fig. 1 How to remove rod seal

Series CG5-S

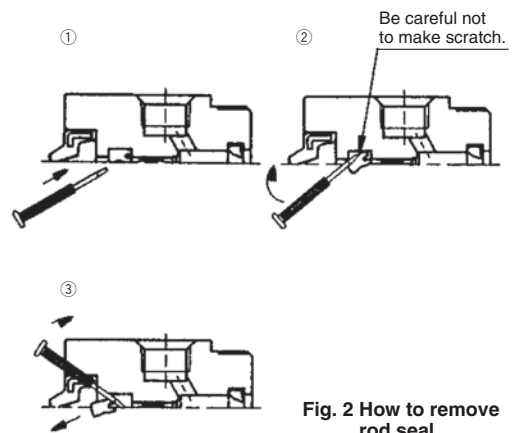

Fig. 2 How to remove rod seal

3-2. Piston seal

Wipe off grease around piston seal first to make removal easier.

Hold piston seal with one hand and push it into groove so that piston seal can be lifted off and pulled out without using a watchmakers screw driver. (Fig. 3)

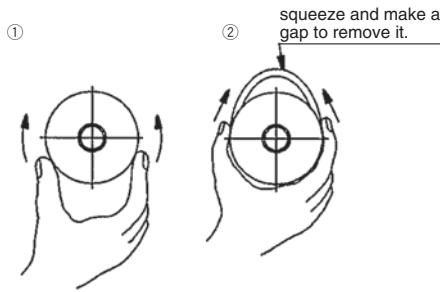

Fig. 3 How to remove piston seal

3-3. Tube gasket

Remove the tube gasket with the watchmakers screw driver or the like.

3-4. Valve seal, valve retaining gasket (Air cushion style only)

After disassembling by referring to Figure 4, pull out them by using a watchmakers screw driver.

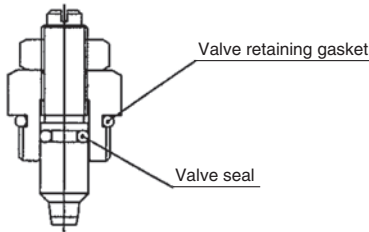

Fig. 4 Positions of valve seal and valve retaining gasket

3-5. Lock piston seal (End lock section)

Series CBG1

- a. Insert the manual bolt through the rubber cap of the end lock unit (This is not necessary for -*L lock style).
- b. Unscrew two hexagon socket head cap screws and pull out the end lock unit.
- c. For $\phi 20$ to $\phi 63$, remove the lock piston seal.
- d. For $\phi 80$ and $\phi 100$, remove the seal retainer and lock piston seal.

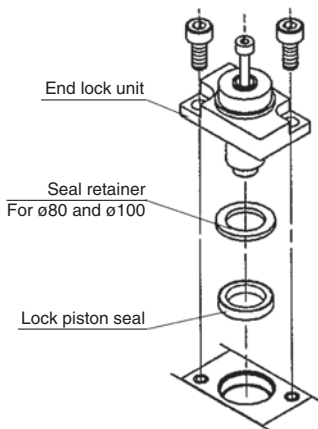

Fig. 5 How to remove lock piston seal

4. Application of Grease

⚠ Caution

Use lithium soap base grease equivalent to JIS class 2.

4-1. Rod seal, lock piston seal

Lightly apply grease to the circumference of a new seal to make mounting easier and have better contact with the cover. Fill in the groove with grease since this is necessary for operation.

4-2. Piston seal

Lightly and evenly apply grease to the inner and outer circumferences for easier mounting on the piston.

4-3. Tube gasket

Lightly apply grease. This prevents its drop when assembling the cylinder.

4-4. Valve seal and valve retaining gasket (Air cushion style only)

Lightly apply grease. This prevents their drop when assembling the valve.

4-5. Cylinder component parts

Apply grease to each component parts of the cylinder in Figure 6. Appendix table shows the grease amount required for a cylinder with stroke 100. For your reference, amount taken with a forefinger is about 3 (g).

$$L \approx 100 \text{ mm, or stroke} \times \frac{1}{2}$$

Series CG1

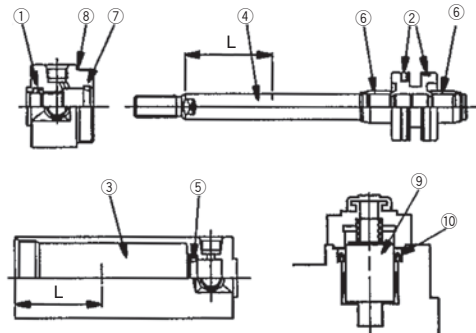

Fig. 6 Grease application points

Series CBG1/ End lock section

Grease on outer circumference



① Rod seal

Approx. 3 g A little under 1 cm



Grease amount

Grease application amount (g)

Stroke	Bore size				Application points
	ø20	ø25	ø32	ø40	
100 st	2	3	3	3 to 4	①②③④⑤ ⑥⑦⑧⑨⑩
Extra 50 st	0.5	0.5	0.5	1	③④

* Rubber bumper style does not have ⑤, ⑥, and ⑦.
* ⑨ and ⑩ are the end lock parts of Series CBG1.

Series CG3

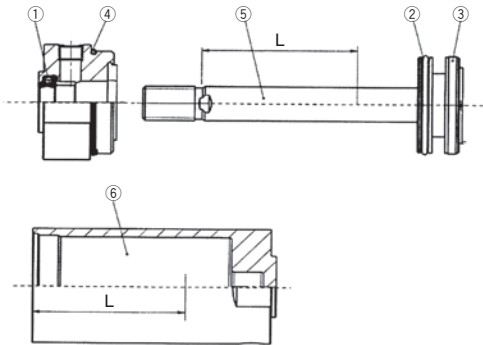

Fig. 7 Grease application points

Grease application amount (g)

Stroke	Bore size				Position for grease
	ø20	ø25	ø32	ø40	
At 100 st	2	3	3	3 to 4	①②③ ④⑤⑥
50 st increased	0.5	0.5	0.5	1	⑤⑥

5. Mounting of Seal

5-1. Rod seal

Be careful with the direction of seal while mounting. Apply grease to the seal and the inner circumference of the bush as Figure 8. For small bore sizes, use a watchmakers screw driver to apply grease.

5-2. Piston seal

After mounting the seal, rub grease into the seal groove and the outer circumference of the seal as Figure 9.

5-3. Tube gasket

Install the tube gasket to the cover.

5-4. Valve seal, valve retaining gasket (Air cushion style only)

By referring to Figure 4, install them to the specified position.

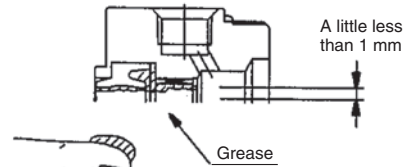

Fig. 8 Rod seal

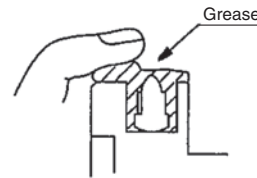

Fig. 9 Piston seal

Series CG5-S

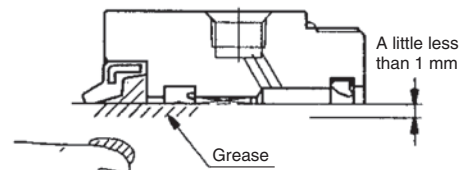

Fig. 10 Rod seal

⚠ Caution

Make sure that there is nothing wrong with operation and air leakage when assembly is completed.

1. Disassembly of the Cylinder

The cylinder needs to be disassembled and assembled in a clean place.

Series MB/MB1

For work tools, refer to the Table 1.

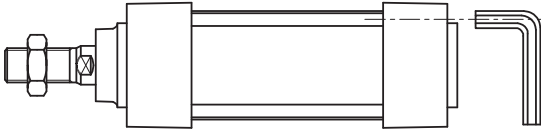

Table 1 Work tools

Bore size	Width across flats of a hexagon wrench	
	When removing the support bracket	When removing the tie-rod nut
32, 40	4	6
50, 63	5	8
80, 100	6	10
125	8	12

Series CA2

For work tools, refer to the Table 2.

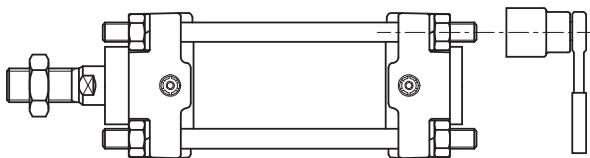

Table 2 Work tools

Bore size	Applicable socket
40, 50	13 (M8)
63	17 (M10)
80, 100	19 (M12)

2. Removal of the Seal

2-1. Rod seal, cushion seal

Insert a watchmakers screw driver to pull out the seals.

Take care not to damage the seal groove of the cover. (Fig. 1)

2-2. Piston seal

Remove it as in Fig. 2.

2-3. Tube gasket

Remove it in the same way as Fig. 2.

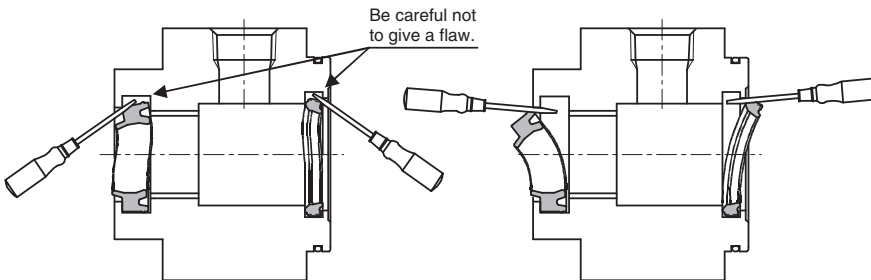

Fig. 1 Removal of rod seal and cushion seal

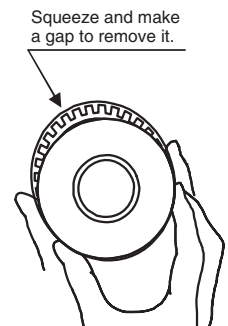

Fig. 2 Removal of piston seal

3. Application of Grease to Seal

- 3-1. Apply grease slightly to the outer circumference of each seal.
- 3-2. Fill in the groove of the rod seal with grease.

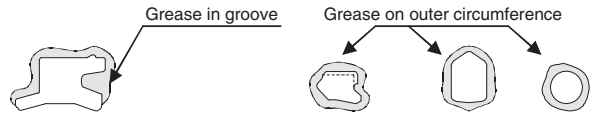

Fig. 3 Grease to the seals

4. Mounting of Seal

- 4-1. Rod seal, cushion seal
Mount the seal in the correct direction by bending the seal with fingers as Fig. 4.
- 4-2. Piston seal
Mount the seal while stretching it as in Fig. 5.

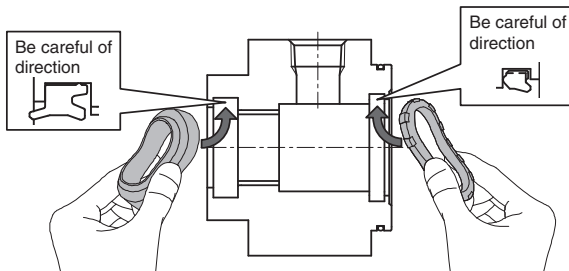

Fig. 4 Mounting of rod seal, cushion seal

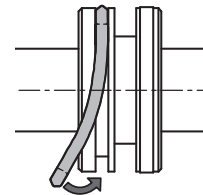

Fig. 5 Mounting of piston seal

5. Application of Grease

- 5-1. Rod seal, cushion seal
Apply grease to the seal and the inner circumference of the bush. (Fig. 6)
- 5-2. Piston seal
Rub grease into the seal groove and the outer circumference of the seal. (Fig. 7)
- 5-3. Cylinder component parts
Apply grease to each component parts of the cylinder in Figure 9. Appendix table shows the grease amount required for a cylinder with stroke 100. For your reference, amount taken with a forefinger is about 3 g. (Fig. 8)

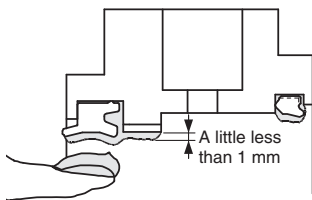

Fig. 6 Rod seal
Cushion seal

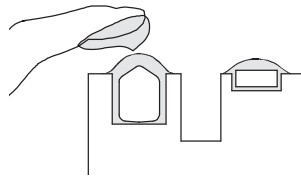

Fig. 7 Piston seal

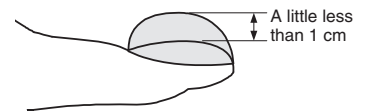

Fig. 8 Grease amount

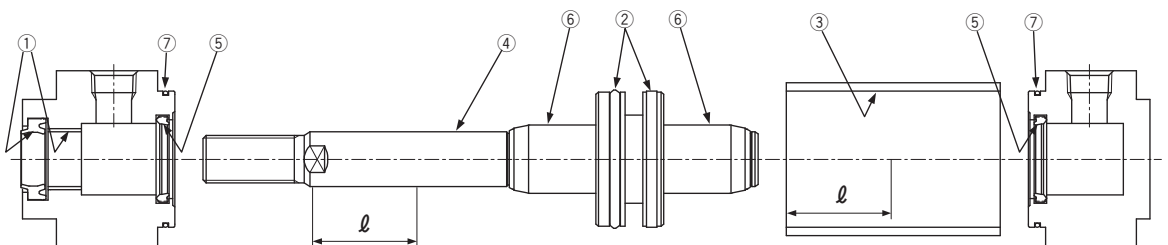

Fig. 9 Grease application points

$$l = \frac{\text{STROKE}}{2} \text{ or } 100 \text{ mm and more}$$

Actuators

Modular F.R.L.
Pressure Control Equipment

Air Preparation
Equipment

Industrial Filters

Replacement
Procedure

Actuators

Modular F.R.L.
Pressure Control Equipment

Industrial Filters

Series MB/MB1/CA2 Replacement Procedure of Seal 3

Table 3 Grease application amount (g)

Stroke	Bore size							Application points
	32	40	50	63	80	100	125	
100 st	3 to 4	3 to 4	3 to 5	4 to 5	6 to 8	8 to 10	15 to 17	①②③④⑤⑥⑦
Extra 50 st	1	1	1	1.5	1.5	2	3	③④

6. Reassembly of the Cylinder

- 6-1. Make sure no particles are present. Do not scratch the seals.
- 6-2. To assemble the tie rod to the cylinder, tighten the tie rod to the shorter screw side by hand.
- 6-3. Set the tie rod nuts from the cover on the opposite side. Tighten the tie rod nut so that the tensile force is even.
Refer to the appropriate tightening torque of table 4 and 5.
Brackets refer to the same table.

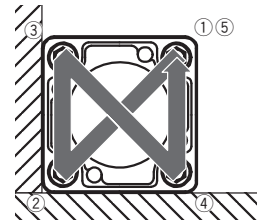

Fig. 10 Tie rod tightening order

Series MB/MB1

Table 4 Appropriate tightening torque

Bore size	Appropriate tightening torque (N·m)
32, 40	5.1
50, 63	11.0
80, 100	25.0
125	30.0

Series CA2

Table 5 Appropriate tightening torque

Bore size	Appropriate tightening torque (N·m)
40, 50	10.8
63	24.5
80, 100	38.2

Series CS1/CS2 Replacement Procedure of Seal 1

1. Disassembly

- 1-1. Disassembly should be done in a wide space containing little dust.
- 1-2. After removing the cylinder, be sure to protect the end of piping port and rubber hose on the machine side with clean waste to prevent dust from entering.
- 1-3. Disassemble the unit with care to prevent damage to the sliding portion.
- 1-4. Check the double chamfered portion at the rod end for burrs to prevent damage to the seal and the bushing when removing the cover (push plate) from the piston rod. If burrs are found, remove them with a "file".
- 1-5. Loose either of nuts for tie rod with "ratchet handle for socket wrench", "T-type slide handle for socket wrench" or "spinner handle for socket wrench", etc. and remove it from the tie rod. Please refer to the table for "socket for socket wrench".

Series CS1		
Bore size (mm)	Nut	Applicable socket
125, 140	Class1, M14 x 1.5	JISB4636 Dodecagon 22
160	Class1, M16 x 1.5	JISB4636 Dodecagon 24
180	Class1, M18 x 1.5	JISB4636 Dodecagon 27
200	Class1, M20 x 1.5	JISB4636 Dodecagon 30
250	Class1, M24 x 1.5	JISB4636 Dodecagon 36
300	Class1, M30 x 1.5	JISB4636 Dodecagon 46

Series CS2		
Bore size (mm)	Nut	Applicable socket
125, 140	Class2, M14 x 1.5	JISB4636 Dodecagon 22
160	Class2, M16 x 1.5	JISB4636 Dodecagon 24

- 1-6. Remove 4 tie rods from cover.
- 1-7. Remove the push plate (rod cover) from the piston rod with care to prevent damage to the seal and bushing.
- 1-8. Pull the piston rod and pull out the piston from the cylinder tube.
- 1-9. Remove the cylinder tube from the head cover.
- 1-10. Disassembly of the rod cover (For the head cover, it should also be in accordance with this procedure.)

- | Series CS1 | |
|--|---|
| <ol style="list-style-type: none"> a. Remove the cylinder tube gasket. When excessive deformation or cut is found with the gasket, replace it. b. Remove the cushion cover from the cover by using "flat blade screwdriver".
(Tool; Screwdriver Nominal size 8 x 150 Normal type, Normal class) c. Remove the cushion valve seal from the cushion valve by using "waste". | <ol style="list-style-type: none"> d. Loosen the hexagon socket head cap screw for push plate by using "hexagon wrench" and remove the push plate. Applicable "Hexagon wrenches" are shown in the table below. |

Bore size (mm)	Hexagon socket head cap screw	Nominal size of wrench
125, 140, 160	M8 x 1.25 x 25L	6
180, 200	M10 x 1.5 x 30L	8
250, 300	M12 x 1.75 x 35L	10

- e. Remove the wiper ring. If it cannot be removed by hand, use a small "flat blade screwdriver" and remove it with care to prevent damage to it.
- f. Remove the rod seal by using a small "flat blade screwdriver" with care to prevent damage to it.
- g. Remove the push plate gasket.
- h. Since the cushion seal is pressed fit, air will leak from the portion where the cushion seal is pressed fit due to damage or change in pressing force. Therefore when the cushion seal should be replaced, the rod cover assembly and the head cover assembly should be replaced. (For those that are to be assembled with the Class 2 pressure vessel, the rod and head covers cannot be replaced. Please consult SMC as required.)
- i. Since the bushing is pressed fit into push plate, it is difficult to remove structurally and even if it is removed, stock for press fit lowers when it is pressed fit again. Therefore when it is replaced, replace the push plate assembly.

- | Series CS2 | |
|--|--|
| <ol style="list-style-type: none"> a. Remove the cylinder tube gasket. When excessive deformation or cut is found with the gasket, replace it. b. Pick out the rod seal with a small flat blade screwdriver carefully not to damage seal and rod cover. c. Remove the cushion seal from the cover by using a small flat blade screwdriver carefully not to damage seal and rod cover. d. The bushing is pressed fit to the rod cover and difficult to remove. Even if it can be removed, the allowance for press-fit is reduced, which requires the replacement as a rod cover assembly. | <ol style="list-style-type: none"> 1-6. Remove 4 tie rods from cover. 1-7. Remove the push plate (rod cover) from the piston rod with care to prevent damage to the seal and bushing. 1-8. Pull the piston rod and pull out the piston from the cylinder tube. 1-9. Remove the cylinder tube from the head cover. 1-10. Disassembly of the rod cover (For the head cover, it should also be in accordance with this procedure.) |

Actuators

Modular F.R.L.
Pressure Control Equipment

Air Preparation
Equipment

Industrial Filters

Replacement
Procedure

Actuators

Modular F.R.L.
Pressure Control Equipment

Industrial Filters

Series CS1/CS2 Replacement Procedure of Seal 2

2. Replacement Procedure of Seal

2-1. Removal of the seal

Please refer to "1. Disassembly" for dismantling of wiper ring, rod seal, valve seal, tube gasket and push plate gasket.

Since piston seal has a deep groove for sealing, use your hand (not a watchmakers screw driver) and push from one side of seal and pull it out when it lifts off.

2-2. Application of grease

- a. Seal: Apply thin coat of grease.
- b. Cylinder component

Apply grease to the individual components as the figure below. The table shows the grease amount required for a cylinder with stroke 100.

Series CS1

Grease application amount (g)

Bore size (mm)	125	140	160	180	200	250	300	Portion to apply
100st	15 to 17	20 to 22	24 to 26	27 to 29	30 to 32	33 to 35	36 to 38	① to ⑥
50st extra	3	3	3	4	4	5	5	③④

For grease, use lithium soap group grease JIS #2.

Series CS2

$$L = \frac{\text{STROKE}}{2} \text{ or } 100 \text{ mm and more}$$

Grease application amount (g)

Bore size (mm)	125	140	160	Portion to apply
100st	15 to 17	20 to 22	24 to 26	① to ⑥
50st up	3	3	3	③④

For grease, use lithium soap group grease JIS #2

2-3. Mounting of seal

Series CS1

- a. Wiper ring/Rod seal
Mount in correct direction.
- b. Seals other than wiper ring
After mounting seals, apply grease on inside diameter surfaces of bushing (rubbing grease into surface).

Series CS2

- a. Cushion seal/Rod seal
Mount in correct direction. N
- b. Seals other than rod seal and cushion seal (Mounting directionless seals)
After mounting seals, apply grease on inside diameter surfaces of bushing (rubbing grease into surface).

3. Assembly

- 3-1. Before assembling cylinder, be sure to clean each part to remove dust.
- 3-2. Before assembling, apply rod, bushing, tube and seal with enough grease.
- 3-3. For rusty part, remove the rust completely.
- 3-4. Assembly should be done in a clean place with care to prevent foreign matters from entering.
- 3-5. Mount seal with care to prevent damage to it.
- 3-6. Insert piston into tube or rod into bushing with care to prevent damage to each seal.
- 3-7. Tighten tie rod and bolt with appropriate torque shown in the table below.

Series CS1

Tightening torque (N·m)

Bore size (mm)	125	140	160	180	200	250	300
Tie rod	Steel tube	49	75.5	103	147.1	254	451.1
	Aluminum tube	39.2	62.8	92.7	132.4	-	-
Push plate bolt	11		22		38		

Series CS2

Tightening torque (N·m)

Bore size (mm)	125	140	160
Tightening torque	39.2	62.8	

Series CUJ Replacement Procedure of Seal 1

1. How to Disassemble

1-1. Disassembly

a. $\phi 4$ to $\phi 10$

Lightly hold the cylinder tube in a vice. Use a spanner on the width across flats of the rod cover and turn it counterclockwise to detach the rod cover.

b. $\phi 12$ to $\phi 20$

Remove the retaining ring with suitable pliers (tools for basic internal retaining ring).

Moreover, please note that the retaining ring comes off from pliers when detaching it, it flies, and the human body and peripherals might be disadvantaged.

1-2. Removal of existing seal

For piston seal and tube gasket (O-ring), pick their edges and pull them out of groove.

For rod seal, use a fine watchmakers screw driver to remove it from the seal groove. At that time, be careful not to scratch the inside of the groove and bearing.

2. How to Assemble

2-1. Mounting of seal

a. Tube gasket (O-ring)

Spread the surface of tube gasket with special grease included in a packing set and mount the gasket in the specified groove. (For double acting cylinders only.)

b. Piston seal

Fill a concavity at the side of piston seal with the special grease. Then, mount the seal in the specified groove without a twist.

c. Rod seal

Spread the entire rod seal and fill U-shape groove with the special grease. Then, mount the

rod seal in the specified groove. Make sure to mount it in the right direction. (For double acting cylinders only.)

2-2. Application of grease to cylinder tube

It is recommended that grease should be applied to cylinder tube in case of seal replacement.

Wipe existing grease with clean waste. Be careful not to scratch the inside of cylinder tube and leave out any fiber of the waste as well. Air leakage may occur otherwise.

2-3. Assembly

a. $\phi 4$ to $\phi 10$

After attaching piston rod assembly to rod cover assembly, set them into cylinder tube.

Tighten the rod cover with the torque specified below.

Tightening torque

$\phi 4$	$\phi 6$	$\phi 8$	$\phi 10$
0.97 N·m ± 10%	3.08 N·m ± 10%	5.02 N·m ± 10%	5.63 N·m ± 10%

b. $\phi 12$ to $\phi 20$

After connecting the piston rod assembly to rod cover assembly, set them into cylinder tube, and install the retaining ring with proper pliers (tool for installing a basic internal retaining ring).

Pay attention that the ring will slip off from the pliers, and cause injury or damage to peripheral equipment. Additionally, ensure the retaining ring is mounted properly into the retaining ring groove.

3. Inspection

Inspect cylinders with replaced seal for proper operation and air leakage so as to confirm there is no defect before use.

Actuators

Modular F.R.L.
Pressure Control Equipment

Air Preparation
Equipment

Industrial Filters

Replacement
Procedure

Actuators

Modular F.R.L.
Pressure Control Equipment

Industrial Filters

Disassembly/Reassembly

Disassemble and assemble the cylinder in a clean area. Perform on a clean cloth.

For disassembling, hold the flats of the tube cover gently in a vice and hold the flats of the rod cover with a spanner or monkey wrench to loosen and remove the rod cover. When reassembling, tighten 2 degrees more than the original position before disassembling.

Caution

1. For installation and removal, use an appropriate pair of pliers (tool for installing a C retaining ring).

Even if a proper plier (tool for installing a C retaining ring) is used, it is likely to inflict damage to a human body or peripheral equipment, as a retaining ring may be flown out of the tip of a plier (tool for installing a C retaining ring). Be much careful with the popping of a retaining ring. Besides, be certain that a retaining ring is placed firmly into the groove of rod cover before supplying air at the time of installation.

2. Only people who have sufficient knowledge and experience are allowed to replace seals.

The person who disassembles and reassembles the cylinder is responsible for the safety of the product.

3. When replacing seals, take care not to hurt your hand or finger on the corners of parts.

Series CBQ2

When more grease is needed due to the maintenance of the cylinder, etc., please order grease pack, which is available separately.

Lock holder mounting bolt is included for $\phi 20$ to $\phi 63$. Be sure to exchange it when disassembling and re-assembling the cylinder, or it may cause of the air leakage.

1. Disassembly of the Cylinder

See the structural drawing and structural parts for disassembly.

1-1. Cleaning of external surface

Remove dusts and foreign matters from external surfaces to prevent them from entering the cylinder during disassembly. In particular, the surface of the piston rod and the collar should be cleaned carefully.

1-2. Removal of retaining ring

Use appropriate pliers (tool for basic internal retaining ring) for removing the retaining ring. Pay attention that the ring will slip off from the end of the pliers, and cause injury or damage to peripheral equipment.

Series CQ2K

Removal of the rod cover holding bolt and collar holding retaining ring.

a. Bore size $\phi 12$ to $\phi 32$

Remove the hexagon socket head cap screw holding the rod cover with a hexagon wrench.

b. Bore size $\phi 40$ to $\phi 63$

Remove the retaining ring with pliers (tool for basic internal retaining ring), and remove the hexagon set screw on the side of the cylinder tube with a hexagon wrench (2mm width across flats). Be careful not to let the ring slip from the end of the pliers as it may cause injury or damage to surrounding equipment.

1-3. Disassembly

Pull out the rod cover and collar through the bolt or nut mounted on the piston rod end, and take the collar out from the piston rod. At that time, take care not to damage the internal surface of the cylinder tube and the bushing of the collar.

Series CBQ2

a. Removal of the end lock: Fig. 1.

Locking piston seal

Insert the manual bolt and screw it in over the rubber cap of the end lock unit to the internal lock piston. (It is not necessary for \rightarrow L. lock type) Remove 2 hexagon socket head cap screws and pull off the end lock unit.

As for $\phi 20$ to $\phi 63$, remove locking piston seal.

As for $\phi 80$ and $\phi 100$, remove packing retainer and lock piston seal.

Then remove lock holder mounting bolt and remove the lock unit and gasket.

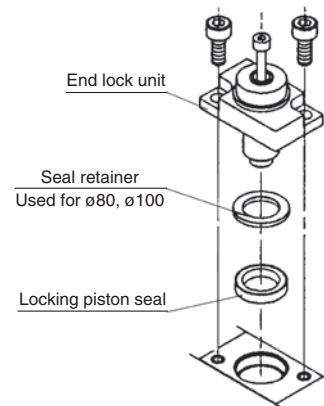

Fig. 1 How to remove end lock

2. Removal of the Seal

2-1. Rod seal

Tool: Watchmakers screw driver, etc.
 Insert a watchmakers screw driver from the front side of the cover as shown in Fig. 2.
 Take care not to damage the seal groove of the cover at this time.

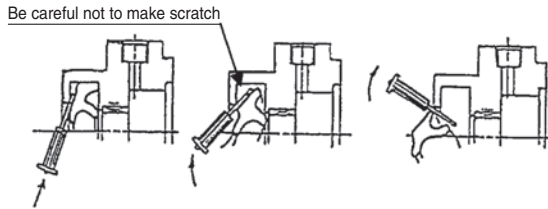

Fig. 2 Removal of Rod packing

Series CQ2

Insert the watchmakers screw driver from the back of the rod cover and collar to pull out the rod seal. Do not damage the seal groove on the collar at this time.

2-2. Piston seal

Wipe off grease around piston seal first to make removal easier.
 Hold piston seal with one hand and push it into groove so that piston seal can be lifted off and pulled out without using a watchmakers screw driver. (Fig. 3)

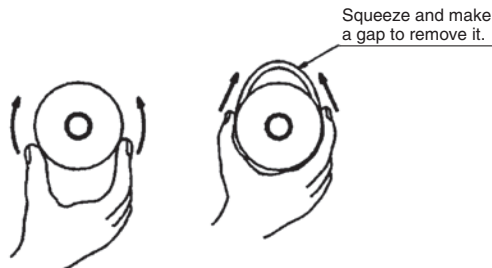

Fig. 3 Piston seal

2-3. Tube gasket

Remove the tube gasket with the watchmakers screw driver or the like.

3. Application of Grease

3-1. Rod seal

Apply grease around the replacement seal. Fill grease in the groove. (Fig. 4)



Fig. 4 Rod seal

3-2. Piston seal

Apply grease thinly and evenly to the external and internal peripheries of the piston seal to ensure easy fitting to the piston.



Fig. 5 Piston seal

3-3. Tube gasket

Thinly apply grease to the tube gasket. Grease will help prevention of dropping off during fitting the cylinder.

3-4. Cylinder parts

Apply grease to all points of cylinder parts as shown in Figure 6. Grease in quantities show in Table 1 are required for each of 100 mm stroke cylinders in accordance with their diameters.
 The quantity of grease taken up by the forefinger as shown in Figure 8 is approximately 3 g.

$$L \approx 100 \text{ mm or Stroke} \times \frac{1}{2}$$

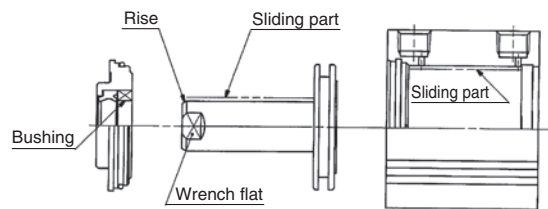

Fig. 6 Grease application points

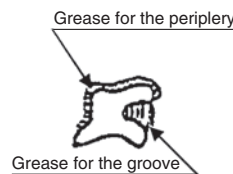

Fig. 7



Fig. 8 Grease amount

Table 1 Grease application amount

Stroke	Bore size (mm)	20	25	32	40	50	63	80	100
	100 stroke		2	3	3	3 to 4	3 to 5	4 to 5	6 to 8
Additional 50 stroke		0.5	0.5	0.5	1	1	1.5	1.5	2

(g)

Series CQS/CQ2/RQ/CXT/CVQ Replacement Procedure of Seal 3

b. Apply grease to the sliding part of each part.

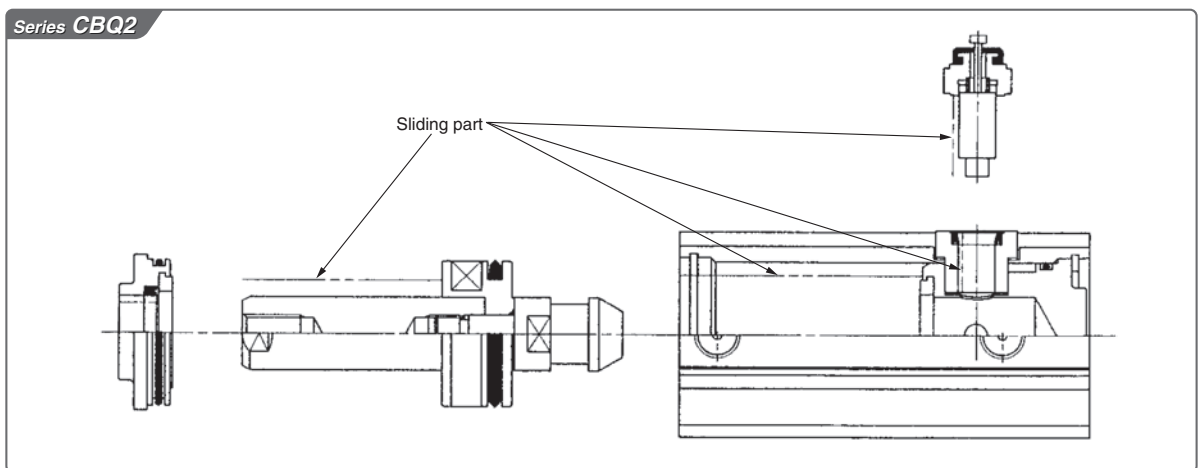
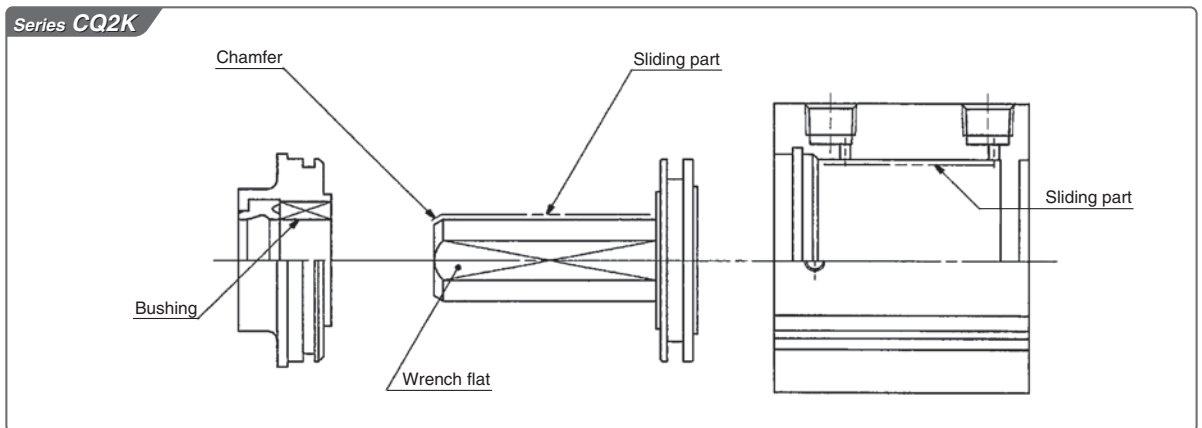
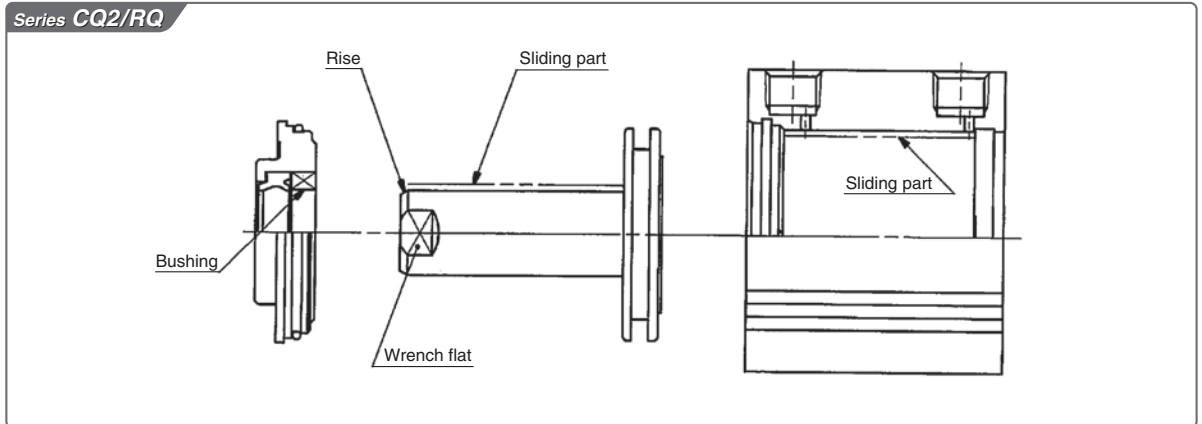

4. Mounting of Seal

4-1. Rod seal

Mount the seal in the correct direction.

After mounting, apply grease to the seal and bushing evenly.

For small diameter cylinders, apply grease using the watchmakers screw driver.

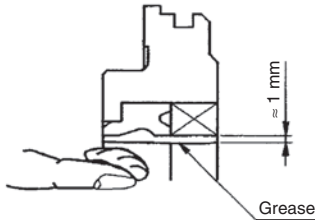

Series **CQ2K**

To mount the rod seal in the correct direction, the whole internal sliding surface of the guide and rod seal should be visible when looking at the rod cover assembly from the piston side.

After mounting, apply grease to the seal and bushing evenly.

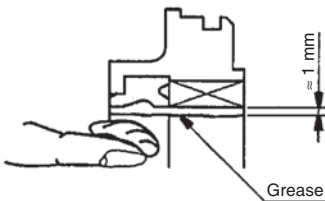

4-2. Piston seal

Mount without twisting. After mounting, apply grease to the external circumference of the seal, and the gap to the mounting groove.



4-3. Tube gasket

Mount the tube gasket on the cover.

5. Reassembly of the Cylinder

- 5-1. Insertion of rod cover and collar to piston rod
Apply grease to the piston rod end or 30° angled raise and wrench flat, and insert the collar gently with care not to damage the rod seal.
- 5-2. Insertion of piston, rod cover and collar to cylinder tube.
Apply grease to appropriate parts of the cylinder tube, and insert the piston and collar gently without any damage to them by the retaining ring groove.

5-3. Mounting of retaining ring

Use appropriate pliers (tool for installing a basic internal retaining ring). Pay attention that the ring will slip off from the pliers, and cause injury or damage to peripheral equipment. Additionally, ensure the retaining ring is mounted properly into the retaining ring groove.

Series CQ2K

- a. Mounting of the rod cover holding bolt and collar retaining ring
- 1) Bore size $\phi 12$ to $\phi 32$
Tighten the hexagon socket head cap screw holding the rod cover with a hexagon wrench to the recommended tightening torque. (Refer to Table for the recommended tightening torque.)
 - 2) Bore size $\phi 40$ to $\phi 63$
Position the collar so that the 4mm hole position on the external circumference aligns with the M4 tap of

the cylinder tube, and tighten the hexagon set screw to the recommended tightening torque. (Refer to Table for the recommended tightening torque.) Use appropriate pliers (tool for installing a basic internal retaining ring). Pay attention that the ring will slip off from the pliers, and cause injury or damage to peripheral equipment. Additionally, ensure the retaining ring is mounted properly into the retaining ring groove.

Bore size (mm)		Rod cover holding hexagon socket head cap screw	Collar holding hexagon set screw	Recommended tightening torque (N·m)
12	Without auto switch	M3 x 0.5 x *L	–	0.59 to 1.06
	With auto switch	M2.5 x 0.45 x 6L	–	0.33 to 0.61
16	Without auto switch	M3 x 0.5 x *L	–	0.59 to 1.06
	With auto switch	M2.5 x 0.45 x 6L	–	0.33 to 0.61
20	Without auto switch	M5 x 0.8 x *L	–	2.84 to 5.10
	With auto switch	M3 x 0.5 x 10L	–	0.59 to 1.06
25	Without auto switch	M5 x 0.8 x *L	–	2.84 to 5.10
	With auto switch	M4 x 0.7 x 10L	–	1.37 to 2.45
32		M5 x 0.8 x *L	–	2.84 to 5.10
40		–	M4 x 0.7 x 4L Truncated cone point	0.20 to 0.39
50		–	M4 x 0.7 x 6L Truncated cone point	0.20 to 0.39
63		–	M4 x 0.7 x 6L Truncated cone point	0.20 to 0.39

* *L: Length of the hexagon socket head cap screw depends on the stroke.

Series CBQ2

a. Mounting of end lock

Apply grease to the lock piston surface and internal lock holder. Insert the gasket and lock holder, then fix with new hexagon socket head cap screw which is attached to the seal kit.

Insert end lock unit and fix with new hexagon socket head cap screw which is attached to the seal kit. (Figure 9, 10, 11, 12)

Tightening torque of bolts for the cap, lock holder

Hexagon socket head cap screw	Applicable bore size	Tightening torque
M3	ø20 to ø63	0.71 to 0.86
M5	ø80 and ø100	2.65 to 3.24

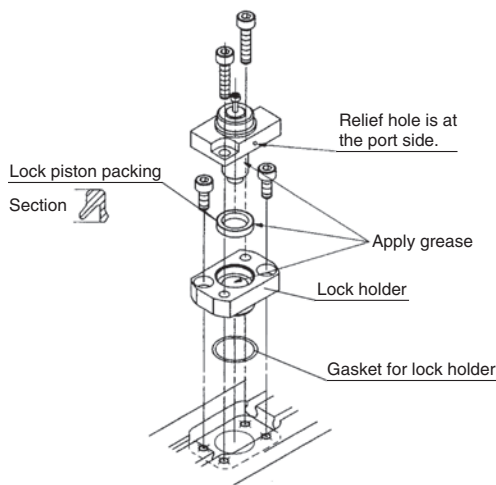

Fig. 9 Reassembling of end lock part (ø20, ø25)

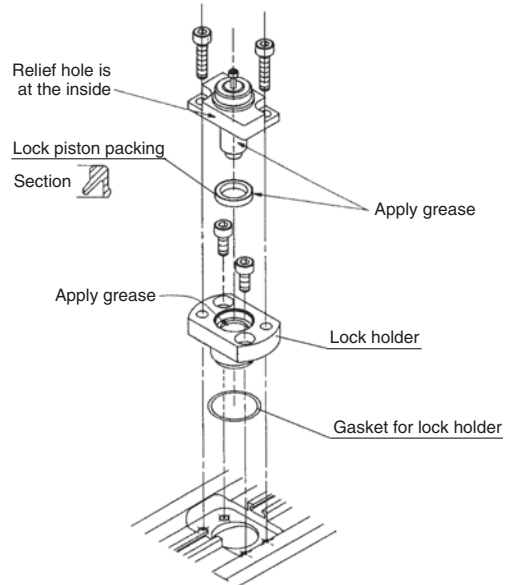

Fig. 10 Reassembling of end lock part (ø32, ø40)

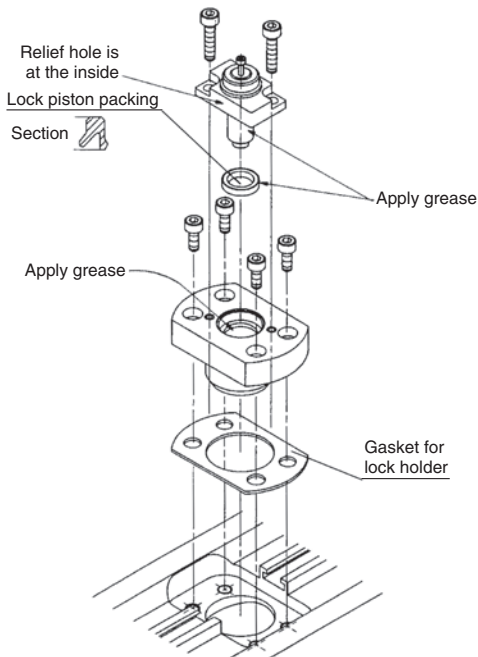

Fig. 11 Reassembling of end lock part (ø50, ø63)

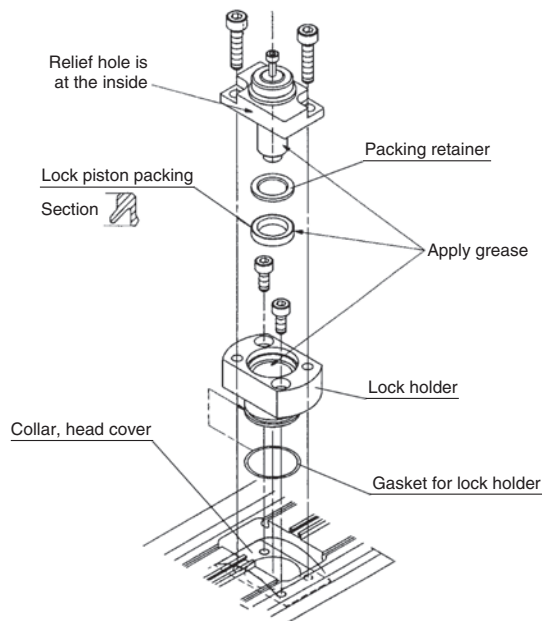

Fig. 12 Reassembling of end lock part (ø80, ø100)

5-4. Check of assembly

Check there is no air leakage at the seal and the minimum operating pressure can realize smooth operation.

Series CXT

Replacement of Driving Cylinder

1. Driving cylinder of this device is normal compact cylinder, so it is possible to replace it. The following is types of cylinder.

Applicable type	Driving cylinder type
CXT□12	CDQSB12-**-DC
CXT□16	CDQSB16-**-DC
CXT□20	CDQSB20-**-DC
CXT□25	CDQSB25-**-DC
CXT□32	CDQ2A32-**-DC
CXT□40	CDQ2A40-**-DC

Driving cylinder type ** indicates stroke.

2. Replacement procedure

Please comply with the following procedure as referring constructions on page 145.

a. Disconnect connection between piston rod²⁴ and adaptor¹⁰ with spanner.

b. Remove 4 bolts fixing plate² to driving cylinder.
Note)

c. Replace driving cylinder to another and fix it with 4 bolts. Please make sure that piston rod²⁴ doesn't touch inside of plate A² hole.

d. Screw adaptor¹⁰ in piston rod²⁴ and tight it with spanner.

Note) In case of cylinder with short stroke, hexagon wrench sometimes doesn't applies between plate A² and slide block¹ due to its narrow space. In that case, replace driving cylinder by removing plate A itself with loosening 2 tightening bolts between plate A and guide axis⁴.

3. In case of replacing only packing etc. of cylinder, replace it after removing cylinder on 2). Please refer to "Appendix. Replacement procedure of cylinder packing"

1. Disassembly of the Cylinder

1-1. Cleaning

Prior to disassembly, wipe off any dirt from the outside of the actuator. This will prevent the intrusion of dust and foreign materials during disassembly.

Take particular care on the surface of the piston rod.

1-2. Removal of switch rail [if the switch is mounted]

Loosen the hexagon bolt and remove the switch rail and switch rail pedestal.

1-3. Removal of rod cover

Series HYQ

Loosen the hexagon socket head cap screw and remove the rod cover.

Series HYC

Loosen the tie rod nut and remove the rod cover.

1-4. Disassembly

Pull out the piston rod by holding a bolt or nut mounted on the piston rod end. Take care not to scratch or mark the internal face of the cylinder tube.

1-5. Removal of the head cover

Series HYQ

Loosen the hexagon socket head cap screw and remove the head cover.

Series HYC

Loosen the tie rod nut and remove the head cover.

2. Removal of the Seal

2-1. Rod seal [Fig. 7]

Insert a watchmakers screw driver etc. from behind the rod cover and prise the seal out. Take care not to scratch or score the seal groove in the rod cover.

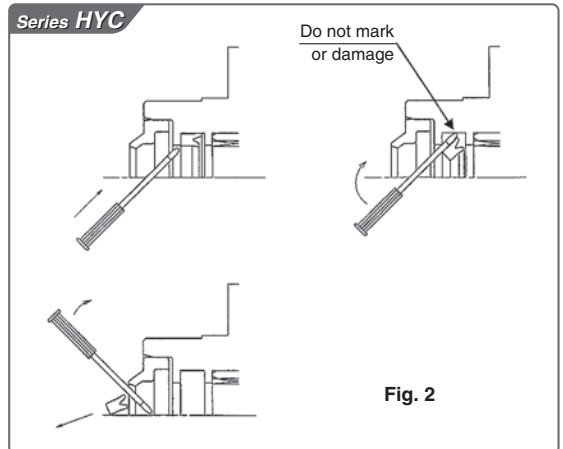
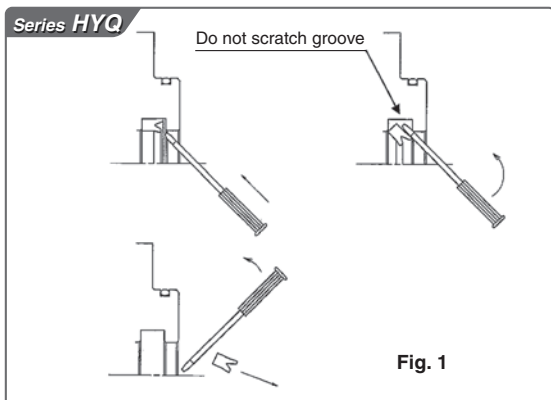

2-2. Cushion seal

Series HYC

Insert a watchmakers screw driver etc. from the front of the rod cover and take out. Take care not to mark or damage the seal groove of the rod cover. Likewise, insert the watchmakers screw driver etc. from the front of the head cover and take out. Do not mark or damage the seal groove of the head cover. (Fig. 3)

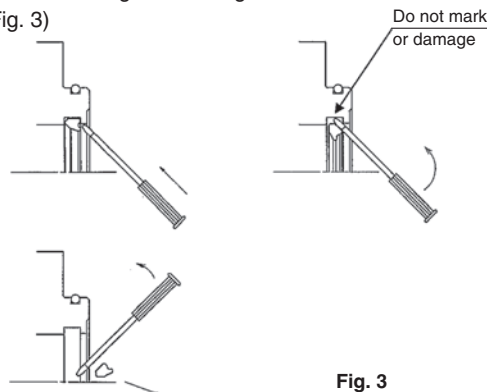

2-3. Piston seal

Since the piston packing is inserted deeply, push it partially to make it come off and pull it out manually. Do not use watchmakers screw driver. (Fig. 4)

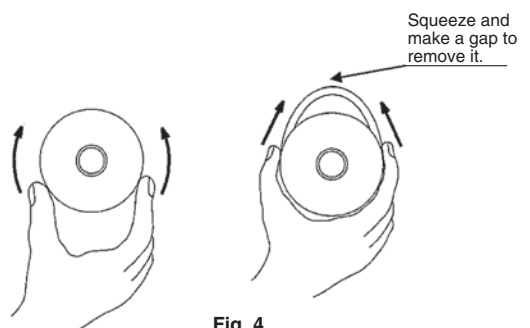

Series HYQ/HYC Replacement Procedure of Seal 2

2-4. Tube gasket

Push the tube gasket partially to make it come off and pull it out manually. (Fig. 4)

2-5. Needle scraper

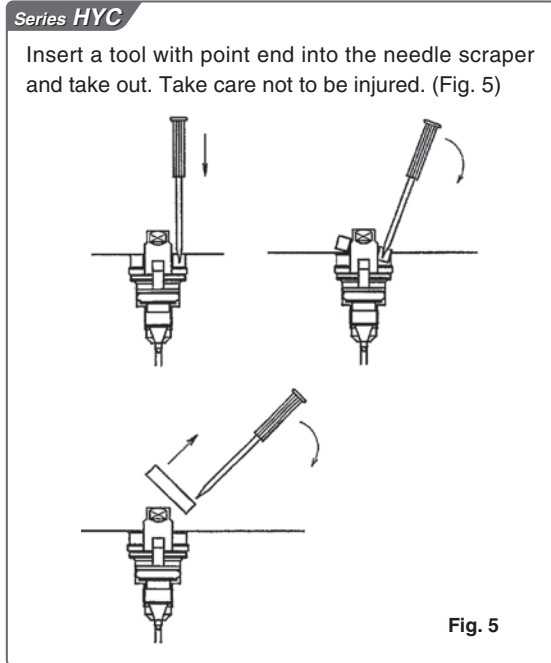

3. Application of Grease

3-1. Rod seal and piston seal [Fig. 6, Fig. 7]

Apply the grease all around new packing evenly. Also add the grease inside the groove.

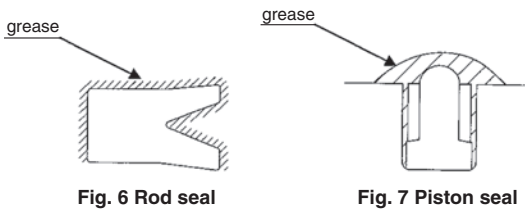

3-2. Cushion seal [Fig. 8]

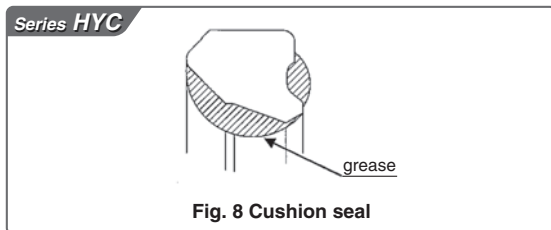

3-3. Tube gasket

Spread a thin film of grease, over the gasket.

3-4. Rod scraper

Fill the rod scraper groove with grease. (Fig. 9)



Fig. 9

3-5. Each component of the cylinder

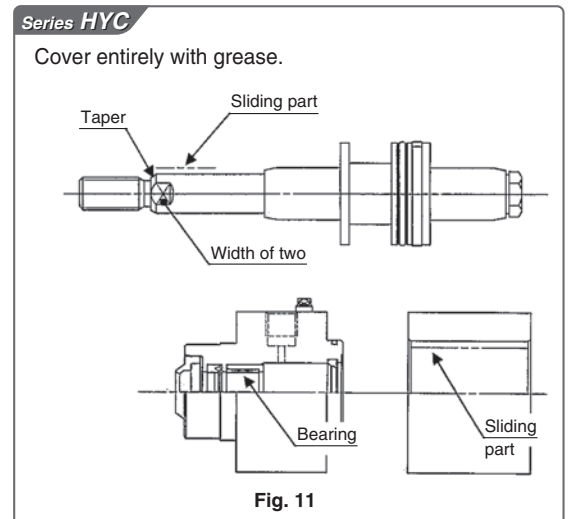
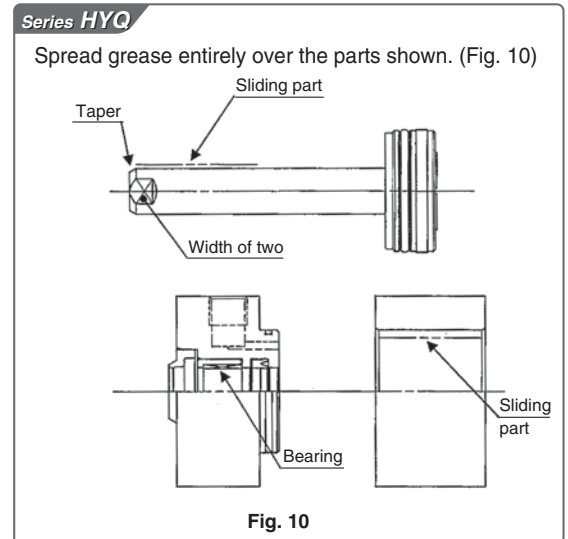

4. Mounting of Seal

4-1. Rod seal

Mount the seal with attention to direction.
Then, apply the grease on the seal and bearing evenly.

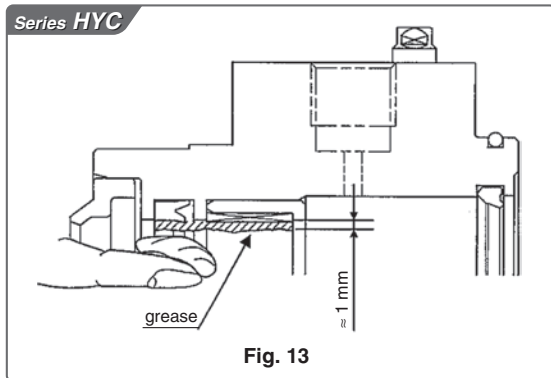
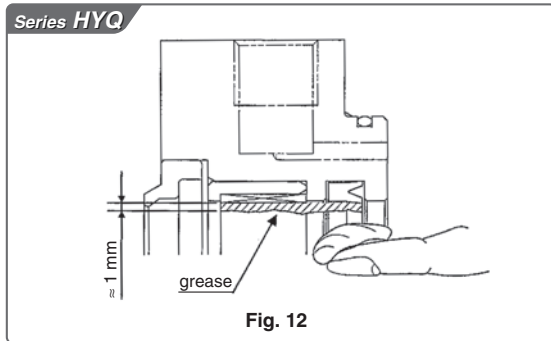

4-2. Piston seal

Make sure not to twist the seal, when mounting.

4-3. Cushion seal

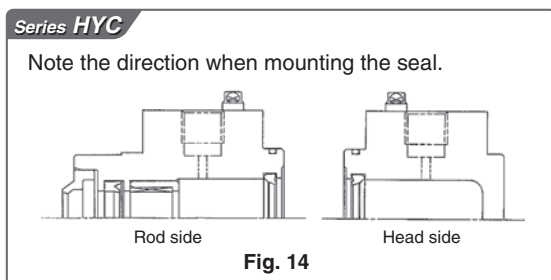

4-4. Tube gasket

Pay attention not to make the gasket come off.

4-5. Needle scraper

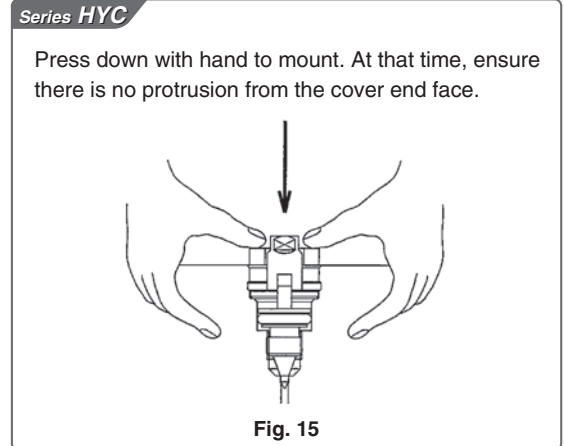

5. Reassembly of the Cylinder

5-1. Tighten the head cover.

Series HYQ

Wipe off the old adhesive from the threaded part of the hexagon socket head cap screw and apply a new layer of adhesive (Loctite 242 (blue)).
Tighten the cylinder tube and head cover with hexagon socket head cap screw.

Table 1

Applicable bore size	Tightening torque (N·m)
ø20	2.1 to 3.9
ø25	3.6 to 6.8
ø32	2.1 to 3.9
ø40	3.6 to 6.8
ø50	8.8 to 16.2
ø63	8.8 to 16.2

Series HYC

Wipe off the adhesive from the threaded part of the tie rod bolt and apply adhesive (Loctite 242 (blue)) newly.
Tighten the cylinder tube and head cover with tie rod bolt.

Table 2

Applicable bore size	Tightening torque (N·m)
ø32	8.8 to 16.2
ø40	17.2 to 31.8
ø50	
ø63	

5-2. Inset the rod assembly into the cylinder tube.

Apply the grease to the part receiving the cylinder tube and insert the rod assembly carefully and slowly make sure the piston packing and gasket are not damaged.

Actuators

Modular F.R.L.
Pressure Control Equipment

Air Preparation
Equipment

Industrial Filters

Replacement
Procedure

Actuators

Modular F.R.L.
Pressure Control Equipment

Industrial Filters

Series *HYQ/HYC* Replacement Procedure of Seal 4

5-3. Tighten the rod cover.

Series *HYQ*

Wipe off the old adhesive from the threaded part of the hexagon socket head cap screw, and apply a new layer of adhesive (Loctite 242 (blue)).

Tighten the cylinder tube and rod cover with hexagon socket head cap screw. (Tightening torque: refer to table 1)

Series *HYC*

Wipe off the adhesive from the threaded part of the tie rod bolt and apply adhesive (Loctite 242 (blue)) newly.

Tighten the cylinder tube and rod cover with tie rod bolt. (Tightening torque: refer to table 2)

5-4. Mount the switch rail (if the switch is mounted).

Applicable bore size	Tightening torque (N·m)
ø20 to ø63	1.1 to 1.9

5-5. Check the assembly condition.

Confirm there is no air leakage from the packing and the cylinder can operate smoothly at minimum operating pressure.

⚠ Caution

Ask SMC for replacing a seal if a tube inside diameter has 40 mm or more.

The cylinder with internal diameter of 40 mm or more has extremely large tightening torque at the rod cover.

Therefore, if the cylinder needs to be disassembled for replacing a seal, ask SMC for the work. SMC can supply a seal kit. However, if the cylinder results in failure or damage after it is disassembled by the other party than SMC, we can't compensate such failure.

1. Disassembly of the Cylinder

1-1. Cleaning

Prior to disassembly, wipe off any dirt from the outside of the actuator. This will prevent intrusion of dust and foreign materials during disassembly.

Take particular care on the surface of the piston rod and guide rod.

1-2. Removal of the assembly

Fix the chamfer on the piston rod, which is retracted, with a spanner, and remove a fixing bolt from a plate by turning the piston rod.

1-3. Removal of the rod cover assembly

Remove the rod cover assembly by rotating the chamfer on the rod cover.

1-4. Disassembly

Pull out the piston rod by holding a nut mounted on the Tightening bolt end. Take care not to scratch or mark the internal face of the body tube.

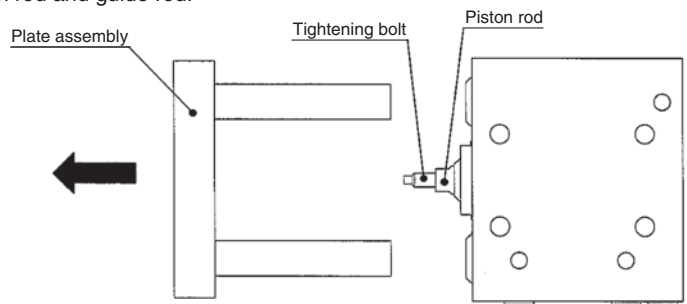

2. Removal of the Seal

2-1. Rod seal

Insert a precision driver etc. from behind the rod cover and prise the seal out. Take care not to scratch or score the seal groove in the rod cover.

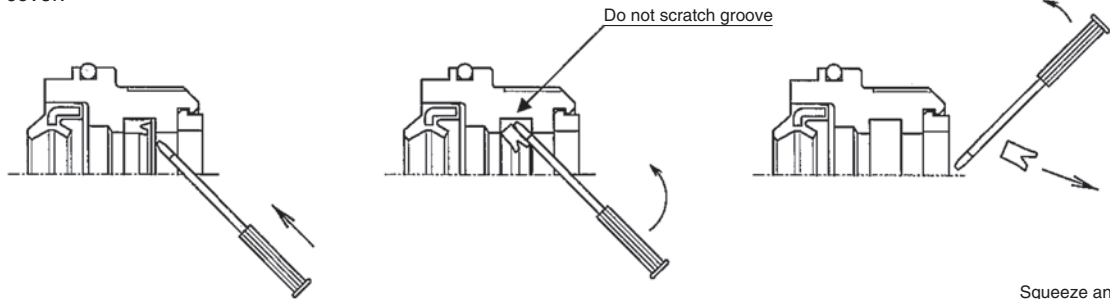

2-2. O-ring (rod side) [Fig. 1]

Push the tube gasket partially to make it come off and pull it out manually.

2-3. Piston seal [Fig. 1]

Since the piston seal is inserted deeply, push it partially to make it come off and pull it out manually. Do not use precision driver.

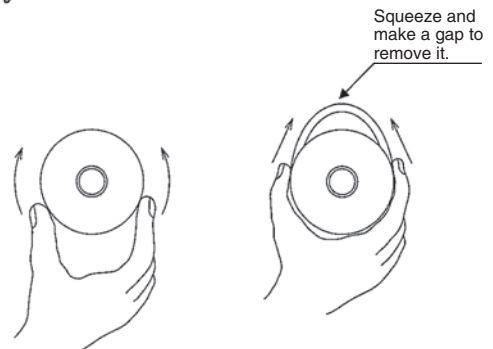

Fig. 1

Series *HYG* Replacement Procedure of Seal ②

3. Application of Grease

3-1. Rod seal and piston seal

Apply the grease all around new seal evenly. Also add the grease inside the groove.

3-2. O-ring (rod side)

Spread a thin film of grease, over the gasket.

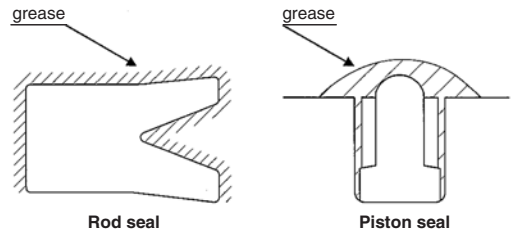

3-3. Scraper

Fill the scraper (part of piston rod and guide rod) groove with grease.

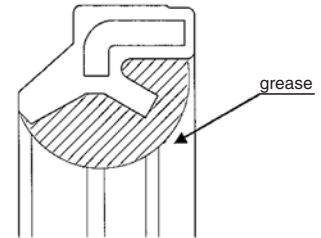

3-4. Each component of the cylinder

Spread grease entirely over the parts shown.

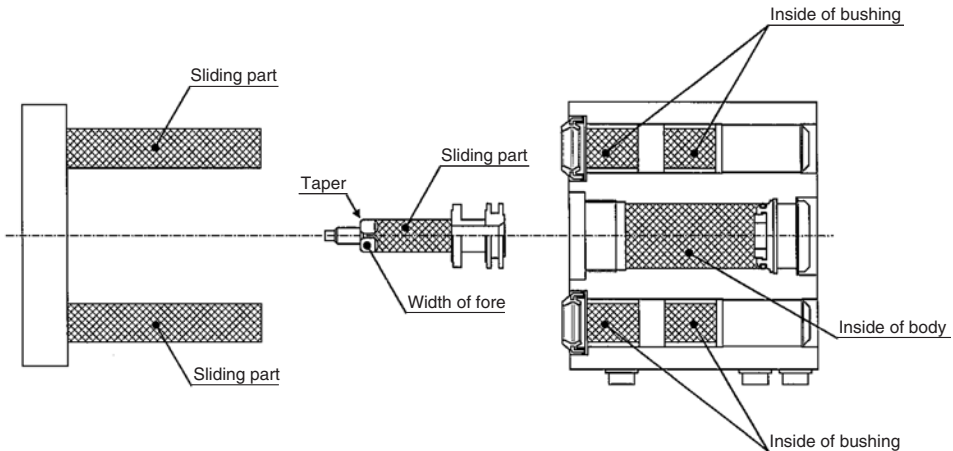

4. Mounting of Seal

4-1. Rod seal

Mount the seal with attention to direction.
Then, apply the grease on the seal evenly.

4-2. Piston seal

When mounting the seal, ensure there are no twists in the seal.

4-3. O-ring (rod side)

Pay attention not to make the gasket come off.

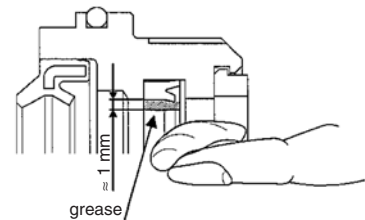

5. Reassembly of the Cylinder

- 5-1. Insert the piston rod assembly into the body.
 Insert the piston rod assembly carefully and slowly, so as not to damage the piston seal.
- 5-2. Tighten the rod cover.
 Tighten the rod cover and the body. (Tightening torque: refer to table 1)
 O-ring must be fit in a groove correctly, and must not be torn out.
- 5-3. Tighten the plate assembly
 Apply adhesive on a thread hole on a plate. (Kind of adhesive: Loctite 262 [red])
 Insert a guide rod of a plate assembly into the body.
 Fixing the chamfer on the piston rod with a spanner, tighten the tightening bolt and the plate assembly by rotating the piston rod.
 (Tightening torque: refer to table 2)
- 5-4. Check the assembly condition.
 Confirm there is no air leakage from the seal and the cylinder can operate smoothly at minimum operating pressure.

Table 1

Bore size (mm)	Tightening torque (N·m)
20	140
25	260
32	500

Table 2

Bore size (mm)	Tightening torque (N·m)
20	2.1 to 3.9
25	3.7 to 6.7
32	8.8 to 16.2

Actuators

Modular F.R.L.
Pressure Control Equipment

Air Preparation
Equipment

Industrial Filters

Replacement
Procedure

Actuators

Modular F.R.L.
Pressure Control Equipment

Industrial Filters

Series MY1B Replacement Procedure of Dust Seal Band 1

1. Disassembly

- Loosen two set screws at one side. That is, four set screws (within dotted line) both sides totally for three rotations.
- Remove end cover by removing two hexagon socket button head screws for fixing on end cover (at both sides of slider).
- Remove the opposite end cover as same way.
- Remove top cover.
- Pull out dust seal band at this condition.

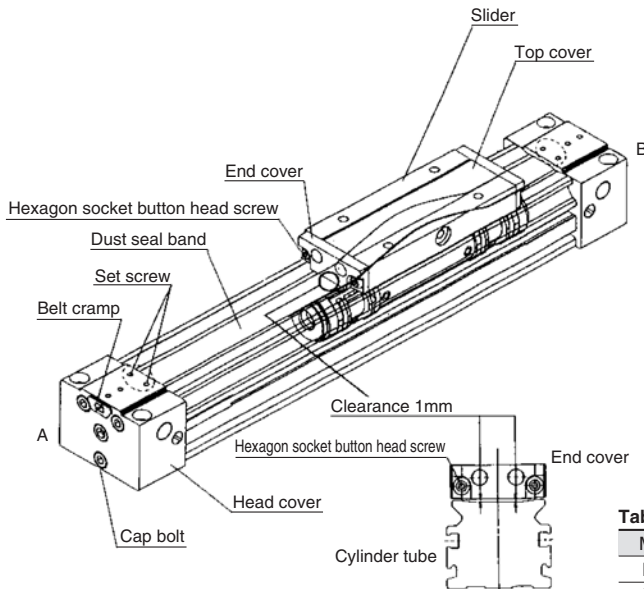
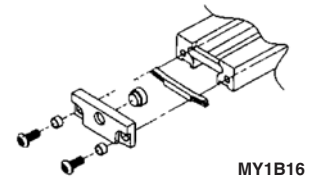

Fig. 1

2. Assembly

- Masking tape (black) of dust seal band for replacement should be removed and applied the grease wholly as Fig. 4^(Note 1) after supplementary process of Fig. 5. (Length of dust seal band is defined as regulated. But check the length again before mounting for shipping.)
- Put dust seal band for replacement in slider.
- Fix end cover assembly so that clearance between end cover assembly and cylinder tube is about 1 mm. In that case, proper tightening torque of hexagon socket button bolt is regulated by values shown in table. 2. Fix the opposite end cover as same way. (Fig. 2) In case of fixing end cover, ensure that spacer, stopper and parallel key are installed.
- Insert both dust seal band into head cover up to line (10 mm). At the same time, put dust seal band in the groove of cylinder tube while stretching dust seal band. Also, as the stainless plate of dust seal band is thin. 0.15 t, be careful not to bend or break in insertion.



MY1B16

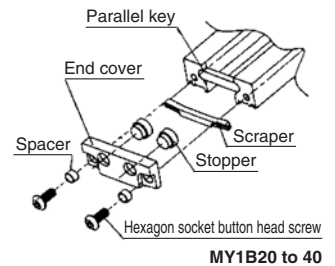

MY1B20 to 40

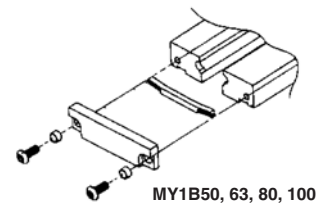

MY1B50, 63, 80, 100

Fig. 2

Table 1. Dust seal band standard list

Model number	Standard length	Model number	Standard length
MY10-16B-st	st + 110 ⁻⁰ / ₀	MY40-16B-st	st + 272 ⁻⁰ / ₀
MY16-16B-st	st + 160 ⁻⁰ / ₀	MY50-16B-st	st + 328 ⁻⁰ / ₀
MY20-16B-st	st + 200 ⁻⁰ / ₀	MY63-16B-st	st + 382 ⁻⁰ / ₀
MY25-16B-st	st + 182 ⁻⁰ / ₀	MY80-16B-st	st + 544 ⁻⁰ / ₀
MY32-16B-st	st + 228 ⁻⁰ / ₀	MY100-16B-st	st + 634 ⁻⁰ / ₀

Note) 2 type of dust seal bands are available and the part no. depends on treatment of setscrew.

- Black zinc chromate → MY**-16B-st
- Nickel plating → MY**-16BW-st

Table 2. Tightening torque of hexagon socket button head screw

Diameter	Bolt size	Tightening torque (N·m)
10		
16, 20	M3 x 0.5	0.3
25, 32, 40	M4 x 0.7	0.7
50, 63, 80, 100	M5 x 0.8	1.5

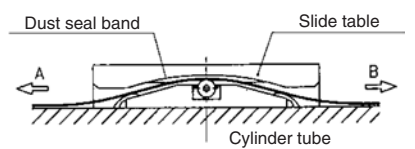

Fig. 3

Series MY1B Replacement Procedure of Dust Seal Band 2

*In case of $\phi 10$, $\phi 80$ and $\phi 100$, Dust seal band is magnetic hold type.

Set the dust seal band on the Cylinder tube with equivalent clearance W_1 and W_2 . (Fig. 5) Another work is same way as above 4.

- e. Tighten only two set screws at A side after installation. In that case, adjust so that dust seal band located near screws does not lift due to excessive tightening. Proper tightening torque is 0.1 N·m {1 kgf·cm}.
- f. Reciprocate slider three or four times up to both stroke ends to remove sagging of dust seal band.
- g. Be sure to return slider up to B side stroke end and tighten at B side as same way after ensuring that dust seal band is inserted into head cover for approx. 10 mm.
- h. Install top cover.
- i. Reciprocate slider for a few times manually again.
If dust seal band does not lift, installation will complete.

Note 1) In case of $\phi 10$, $\phi 80$ and $\phi 100$, dust seal band is made of stainless steel only without masking tape.

Note 2) Apply grease uniformly as Fig. 4. Use lithium soap grease with consistency No. 1 or No. 2.

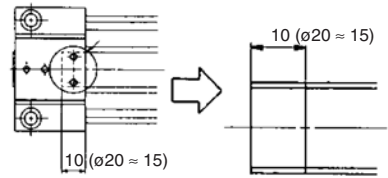

Fig. 4

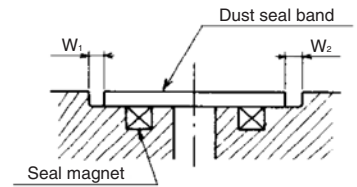

Fig. 5

Actuators

Modular F.R.L.
Pressure Control Equipment

Air Preparation
Equipment

Industrial Filters

Replacement
Procedure

Actuators

Modular F.R.L.
Pressure Control Equipment

Industrial Filters

How to Maintenance

Monthly application of grease to the slide bearing and the dust seal band may lengthen the life.

Grease pack is recommended. (Grease pack number: GR-S-010)

1. Refer to Replacement Procedure of MY1M/C Dust Seal Band.

2. How to install the cylinder with the cover
Refer to Installation Procedure for MY1□W.
3. How to install the side seal of the cylinder with cover.
Refer to Mounting Procedure for MY1□WK side seal.

1. Replacement Procedure of Dust Seal Band

Series MY1M/C

1. Disassembly

- a. Loosen the two set screws at one side, that is, four set screws at both sides.
- b. Remove the end cover by removing two (four) hexagon socket button head screws for fixing which are on the end cover.
- c. Remove the opposite end cover as same way.
- d. Pull out the dust seal band in this condition.

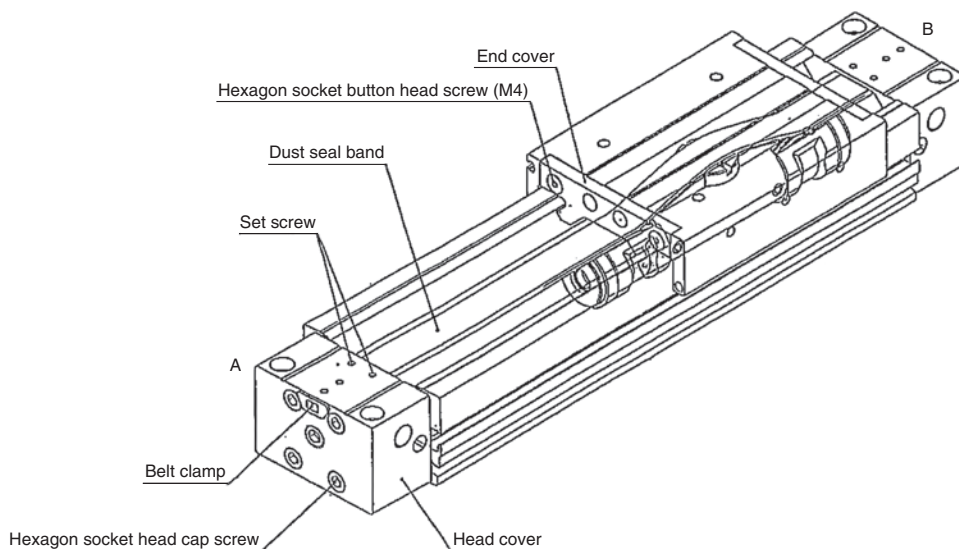

Table. 1 Dust seal band standard list

Model number	Standard length
MY16-16B-st	st + 160 $\begin{smallmatrix} +2 \\ 0 \end{smallmatrix}$
MY20-16B-st	st + 200 $\begin{smallmatrix} +2 \\ 0 \end{smallmatrix}$
MY25-16B-st	st + 182 $\begin{smallmatrix} +2 \\ 0 \end{smallmatrix}$
MY32-16B-st	st + 228 $\begin{smallmatrix} +2 \\ 0 \end{smallmatrix}$
MY40-16B-st	st + 272 $\begin{smallmatrix} +2 \\ 0 \end{smallmatrix}$
MY50-16B-st	st + 328 $\begin{smallmatrix} +2 \\ 0 \end{smallmatrix}$
MY63-16B-st	st + 382 $\begin{smallmatrix} +2 \\ 0 \end{smallmatrix}$

Note) 2 type of dust seal bands are available and the part no. depends on treatment of setscrew.
 Black zinc chromate → MY□□-16B-st
 Nickel plating → MY□□-16BW-st

2. Assembly

- a. The dust seal band for replacement should be added the process of drawing 2 and greased wholly as shown in figure 1.
- b. The dust seal band for replacement is pierced the slide table.
- c. The end cover is fixed so that the clearance between the end cover assembly bottom part and the cylinder tube upper surface is about 1 mm.
The adequate tightening torque at this time is 0.7 N·m (7 kgf·cm).
The opposite end cover is fixed as same way.
- d. The dust seal bands of both sides are inserted in the head cover to the position drawn with a pen (about 10 mm). Then, at the same time, insert the dust seal band in the groove of cylinder tube by pulling it to both sides. (figure 4)
- e. If the dust seal band is installed properly without coming to the surface, tighten two set screws at A side.
Adequate tightening torque is 0.1 N·m (1 kgf·cm).
- f. Reciprocate the slide table three or four times to both stroke ends in order to remove the sag of the dust seal band.
- g. Be sure to return the slide table to B side stroke end and tighten the set screw at B side after ensuring that the dust seal band is inserted in the head cover of about 10 mm.
- h. Reciprocate the slide table again manually a few times and ensure that the dust seal band does not come to the surface.

Note 1) Grease uniformly as the drawing 1. Use consistency No. 1 or No. 2 of the lithium soap grease (such as Mitsubishi Diamond grease multi purpose No. 2).

Table. 2 Tightening torque of button bolt

Diameter	Bolt size	Tightening torque (N·m)
16, 20	M3 x 0.5	0.3
25, 32, 40	M4 x 0.7	0.7
50, 65	M5 x 0.8	1.5



Grease application amount (Shaded portion) = 0.3mm

Fig. 1

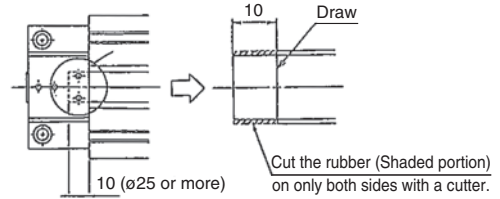

Fig. 2

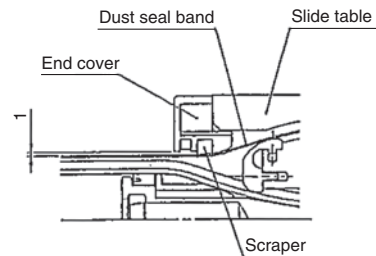

Fig. 3

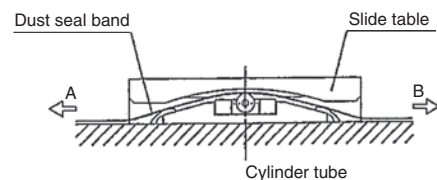
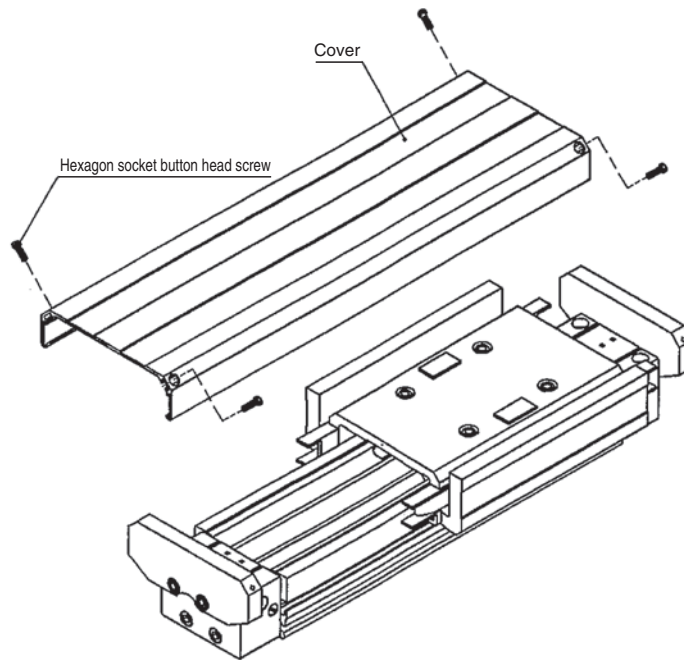

Fig. 4

2. Installation

Series MY1□W

1. Removal of the cover
 - a. Remove the hexagon socket button head screw to remove the cover.



2. Installation, adjustment
 - a. Install the body.
 - b. When the body is equipped only with a cover, the installation is completed when the cover is mounted after the installation and adjustment.

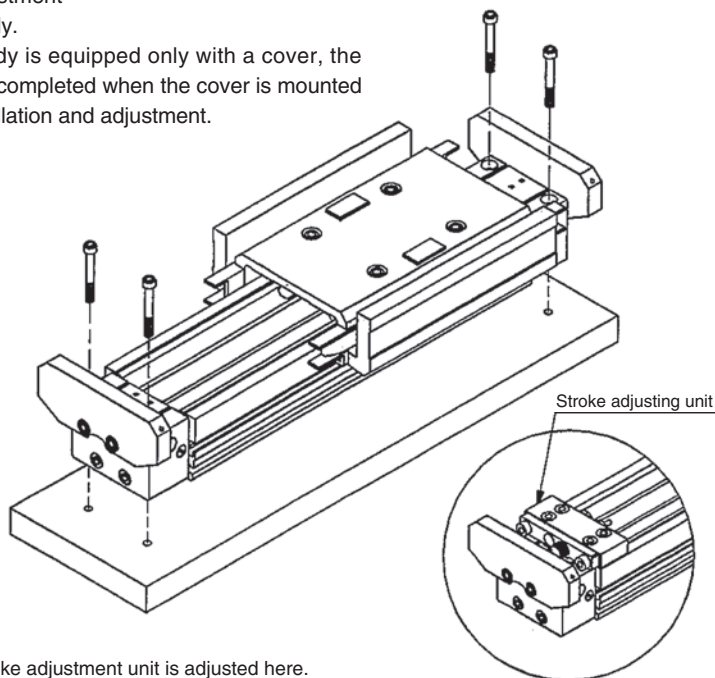

Note) Optional stroke adjustment unit is adjusted here.

3. Installation Procedure of the Side Seal

Series MY1□WK

1. End cover removal procedure

- a. Remove two hexagon socket head cap screws and two hexagon socket button head screws.
- b. Remove the end plate on one end.

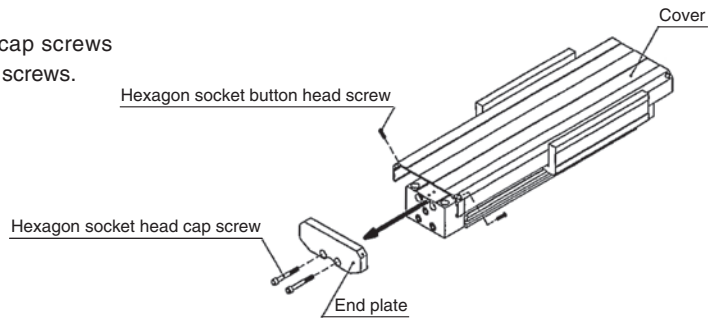

2. Installation of the side seal

- a. Insert the side seal assembly from the end surface.
 Note) The stainless part of the side seal assembly is very sharp. It should be handled with care.

Note) Move the slide table to the end in the retracted direction.

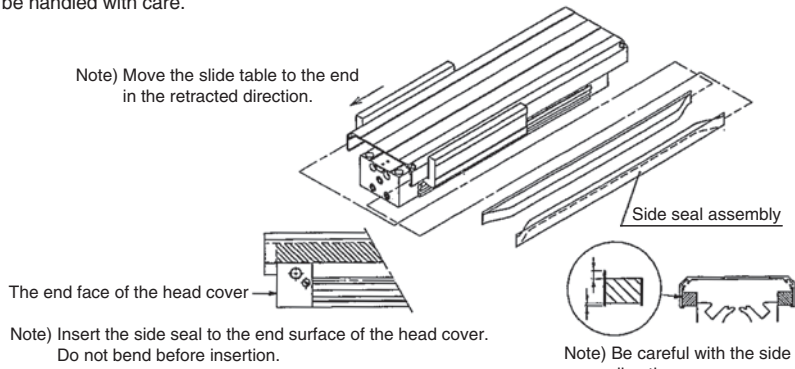

Note) Insert the side seal to the end surface of the head cover. Do not bend before insertion.

Note) Be careful with the side seal assembly direction.

3. Assembly of the cover

- a. Mount the end plate and fix it.

Hexagon socket button head screw

Tightening torque cover (N·m)
(Hexagon socket button head screw)

Torque value	Screw size	Bore size
0.6	M3	All bore common

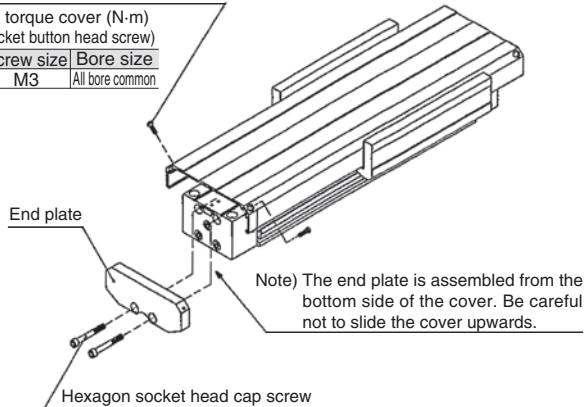

Note) The end plate is assembled from the bottom side of the cover. Be careful not to slide the cover upwards.

Hexagon socket head cap screw

Tightening torque cover (N·m)
(Hexagon socket head cap screw)

Bore size	Screw size	Torque value
ø16	M3	0.6
ø20	M4	1.4
ø25	M5	2.8
ø32	M6	4.8
ø40	M6	4.8

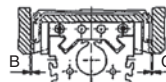

Note) The clearance of B and C part has to be checked at the full stroke. If there is contact, the clearance should be adjusted by loosening the hexagon head cap screw and retightening it.

Actuators

Modular F.R.L.
Pressure Control Equipment

Air Preparation
Equipment

Industrial Filters

Replacement
Procedure

Actuators

Modular F.R.L.
Pressure Control Equipment

Industrial Filters

1. Disassembly

- Loosen the two (three) set screws at one side, that is, four (six) set screws at both sides.
- Remove the end cover by removing two bolt with hex. hole fixing which are on the end cover.
- Remove the opposite end cover as same way.
- Pull out the dust seal band in this condition.

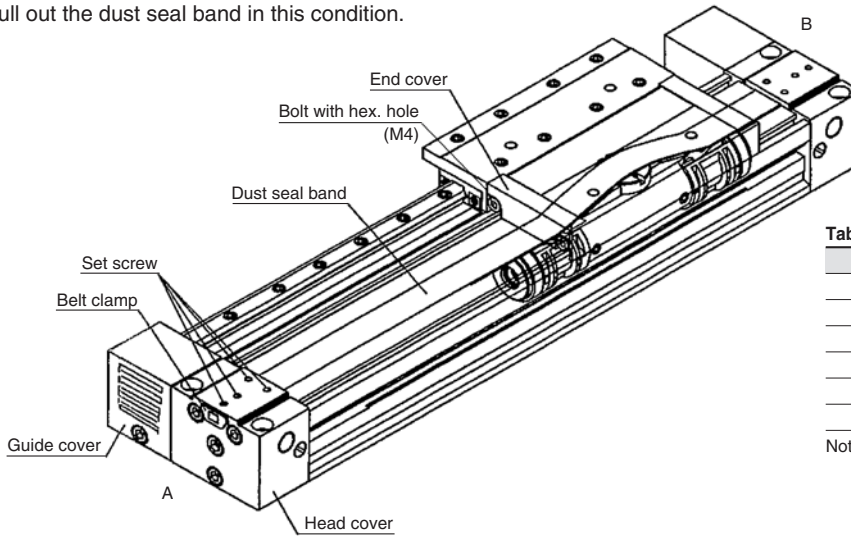

Table 1 Dust seal band standard list

Part number	Standard length
MY10-16B-st	st + 110 ⁺² ₀
MY16-16B-st	st + 160 ⁺² ₀
MY20-16B-st	st + 200 ⁺² ₀
MY25-16B-st	st + 182 ⁺² ₀
MY32-16B-st	st + 228 ⁺² ₀
MY40-16B-st	st + 272 ⁺² ₀

Note) 2 types of dust seal bands are available and the part no. depends on treatment of set screw. (Over $\phi 16$)
 Black zinc chromate → MY**-16B-st
 Nickel plating → MY**-16BW-st

2. Assembly

- The dust seal band for replacement should be greased wholly as shown in figure 1.
- The dust seal band for replacement is pierced the slide table.
- The end cover is fixed so that the clearance between the end cover assembly bottom part and the cylinder tube upper surface is about 1 mm. (fig. 2)
 The adequate tightening torque at this time is 0.7 N·m (7 kgf·cm).
 The opposite end cover is fixed as same way.
- The dust seal bands of both sides inserted in the head cover to the position drawn with a pen (fig. 3). Then, at the same time, insert the dust seal band in the groove of cylinder tube by pulling it to both sides. (fig. 4)
- If the dust seal band is installed properly without coming to the surface, tighten two set screw at A side. Adequate tightening torque is 0.1 N·m (1 kgf·m).
- Reciprocate the slide table three or fore times to both stroke ends in order to remove the sag of the dust seal band.

Be sure to return the slide table to B side stroke end and tighten the set screw at B side after ensuring that the dust seal band is inserted in the head cover of about 10 mm.

- Note 1) Grease uniformly as the fig. 1. Use consistency No. 1 or No. 2 of the lithium soap grease (such as Mitsubishi Diamond grease multi purpose No. 2).
- Note 2) After inserting the dust seal band, pull it by the hands to A and B directions to make it a little tightened, and insert it to the cylinder tube ditch. (fig. 4)
- Note 3) Adequate tightening torque of the set screw is 0.1 N·m (1 kgf·cm).
- Note 4) Ensure that the magic drawing of additional work to the dust seal band (figure 2) is hidden inside the head cover assembly.

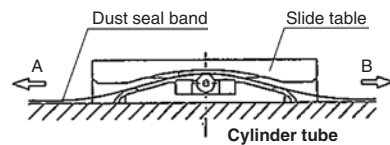
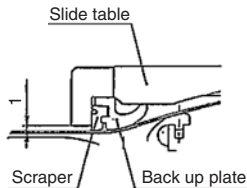
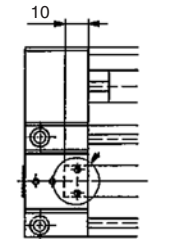
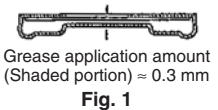

1. Disassembly

- Remove the 4 cap bolts for fixing the cylinder and remove the cylinder from the guide.
- Loosen the 2 set screws on one side (3 screws for $\phi 16$) of the head cover, total 4 screws on both sides (6 screws for $\phi 16$). (Note 1)
- Remove the 2 cap bolts for fixing the end cover to remove the end cover.
- Remove the end cover on the other side in the same way.
- Pull out the dust seal band in this state.

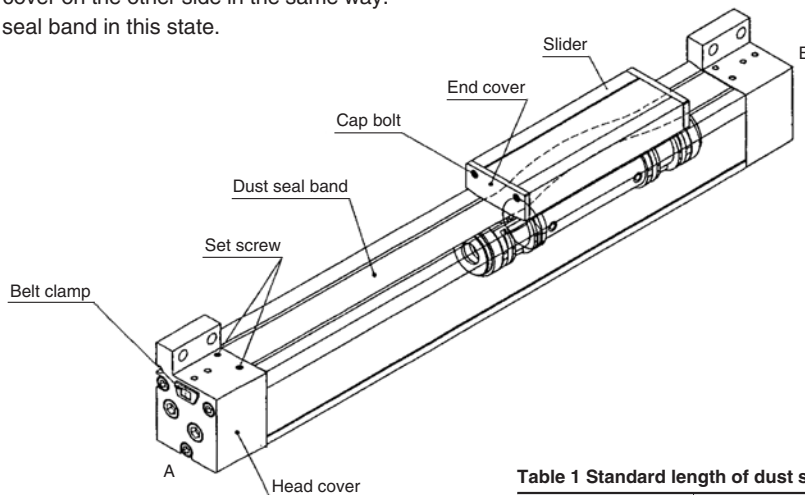
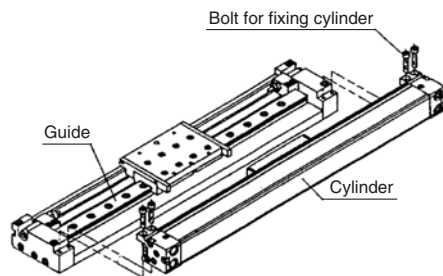

2. Assembly

- Cut the dust seal band for replacement into the dimension shown in Table 1 and bend both ends at about 10° (Figure 2) with L dimension in Table 2 from the position in Figure 1.
- Mount it on the cylinder facing the bent side downward. (Note 2)
- Adjust the end cover to obtain about 1mm clearance between the bottom face of the end cover and the top face of the cylinder tube and fix with care so that the scraper will not drop or twist. (Figure 3)
- Fix the end cover on the other side in the same way.
- Adjust the dust seal band to obtain L dimensions in Table 2 (L dimension: the length of the dust seal band projected from the cylinder tube), and fix the set screws on side A. (Note 3)
- Stretch the dust seal band toward side B and fix it with the set screws on side B.
- Move the slider in full stroke for 2 ~ 3 times to check the dust seal band for fit.
- Apply grease to the sliding part of dust seal band (upper face of the cylinder tube) and mount the cylinder on the guide. (Note 4)

Note 1) For $\phi 16$, remove a belt clamp.

Note 2) Dust seal band is made of thin material. Don't bend it at portions other than those designated.

Note 3) Tightening torque for set screw is 0.1 N·m (1 kgf·cm).

Note 4) For grease, use lithium soap base grease No. 1 or No. 2 (ex. MULTI-PURPOSE No. 2 of MITSUBISHI DIAMOND GREASE)

Table 1 Standard length of dust seal band

Bore size	Standard length
$\phi 16$	Stroke + 160%
$\phi 25$	Stroke + 176%
$\phi 40$	Stroke + 270%

Table 2 L dimension of dust seal band

Bore size	L dimension (mm)
$\phi 16$	20
$\phi 25$	8
$\phi 40$	10

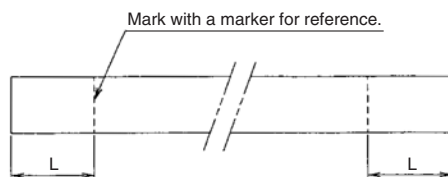

Fig. 1



Fig. 2

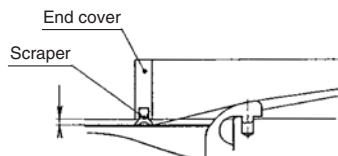

Fig. 3

1. Inspection/Maintenance

Regular grease applying (once a month) to the bearing sliding surface and the dust seal band is recommended for more improvement of life.

Refer to 'Guide for replacement of MY3* dust seal band' to replace the dust seal band.

2. Disassembly/Assembly

Series MY3A/B

Replacement Procedure of Seal Belt

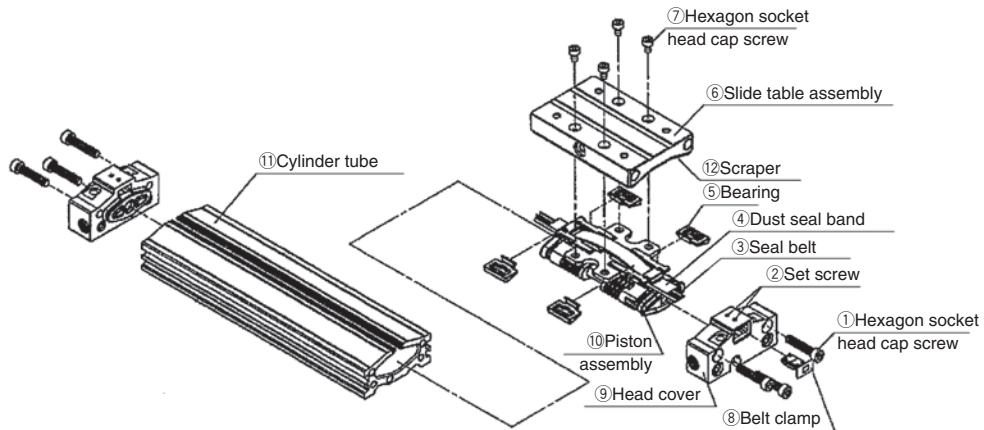

Fig. 1

1. Disassembly

- a. Loosen two setscrews ② on the top head cover ⑨.
- b. Remove belt clamp ⑧.
- c. Remove four retaining hexagon socket head cap screws ⑦ on the top of slide table assembly ⑥.
- d. Remove slide table assembly ⑥. (At this time, please watch that the bearings ⑤ and the scraper ⑫ might fall. (Note 2))
- e. In this condition, Pull out dust seal band ④.
- f. Remove four bearings ⑤ in the right and left from piston assembly ⑩.
- g. Remove three head cover ⑨ retaining hexagon socket head cap screws ①.
- h. Pull out head cover ⑨ from cylinder tube ⑪.
- i. Pull out the other head cover ⑨ from cylinder tube ⑪ in the same method.
- j. Pull out piston assembly ⑩ from cylinder tube ⑪.
- k. Pull out seal belt ③ from cylinder tube ⑪.

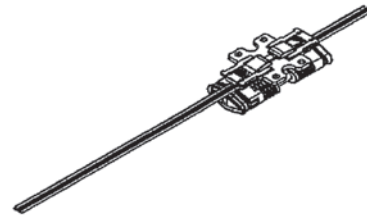

Fig. 2

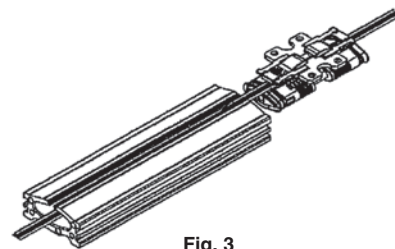

Fig. 3

2. Assembly

- a. Avoid flaws on seal belt, as it may cause air leakage (Pay special attention to the edges indicated by arrows in Figure 4).
- b. Check that the total length of seal belt is of a recommended length and apply grease to the whole surface (Refer to Table 1).
- c. Put seal belt through piston assembly and assemble it to cylinder tube as shown in Figures 2 and 3.
- d. Keep the same extra length of seal belt on both left and right ends of cylinder tube and slowly reciprocate piston assembly once to fit seal belt into cylinder tube. Then reciprocate piston assembly a couple of times more and wipe the extra grease collected forward of the piston off. (When grease remains on the contact side of the piston and the head cover, it may cause the lurching by sticking).
- e. Insert the right and left head cover in the cylinder tube, and tighten head cover retaining hexagon socket head cap screws.
- f. Put dust seal band in piston assembly. (Note 1)
- g. Insert bearing into piston assembly. (Note 1)
- h. Assembly slide table assembly to piston assembly with retaining hexagon socket head cap screws. (Note 1)
- i. Cut off the extra seal belt over the head cover ends with cutter and assembly belt clamp.
- j. Tighten two setscrews each on the top of both head covers. (Note 1)
- k. This is the end of replacement work.
If air leakage is considerable after replacement, consult SMC.

Replacement Procedure of Dust Seal Band

1. Disassembly

- a. Loosen two set screws at one side, that is, four set screws both sides totally for three rotations.
- b. Remove Slide table by removing two hexagon socket button bolts for fixing on Slide table.
Pay attention not to let the bearing and scraper come off when the slid table is removed.
- c. Pull out Dust seal band at this condition.

2. Assembly

- a. Cut the replacement dust seal band to the dimensions shown in Table 1.
*Length of dust seal band is defined as regulated, but check the length again before mounting for shipping.
- b. Pass the replacement dust seal band through the opening (at 2 places) of the belt separator, and mount on the cylinder body.
- c. Set the bearing in place.
- d. Mount the scraper into the groove on the slide table.



Fig. 4

Table 1. Seal belt part no.

	Bore size	Part No.	Recommended length
MY3A	ø16	MY3A16-16A-st	st + 206
	ø20	MY3A20-16A-st	st + 225
	ø25	MY3A25-16A-st	st + 246
	ø32	MY3A32-16A-st	st + 289
	ø40	MY3A40-16A-st	st + 336
	ø50	MY3A50-16A-st	st + 370
MY3B	ø63	MY3A63-16A-st	st + 416
	ø16	MY3B16-16A-st	st + 218
	ø20	MY3B20-16A-st	st + 245
	ø25	MY3B25-16A-st	st + 274
	ø32	MY3B32-16A-st	st + 321
	ø40	MY3B40-16A-st	st + 372
	ø50	MY3B50-16A-st	st + 406
	ø53	MY3B63-16A-st	st + 452

(Note 1) Refer to "Dust Seal Band Replacement Procedure" for dust seal band assembling (installation of the bearing and the slide table assembly).

(Note 2) When parts fall check no adhesion of the foreign objects and assembly it.

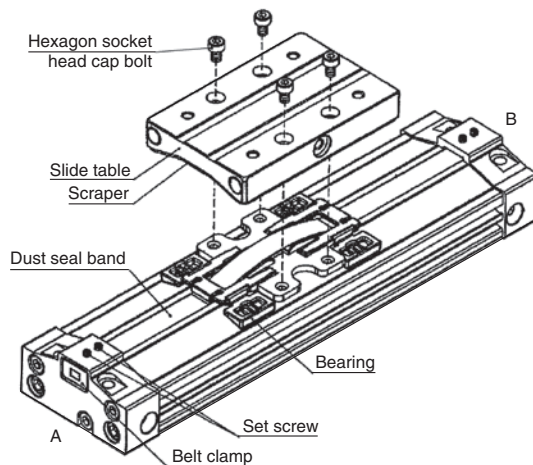

Table 1. Standard length dust seal band

Bore size	MY		MY	
	Part No.	Recommended length	Part No.	Recommended length
ø16	MY3A16-16B-st	st + 106 ⁺⁰ ₋₂	MY3B16-16B-st	st + 118 ⁺⁰ ₋₂
ø20	MY3A20-16B-st	st + 125 ⁺⁰ ₋₂	MY3B20-16B-st	st + 145 ⁺⁰ ₋₂
ø25	MY3A25-16B-st	st + 146 ⁺⁰ ₋₂	MY3B25-16B-st	st + 174 ⁺⁰ ₋₂
ø32	MY3A32-16B-st	st + 189 ⁺⁰ ₋₂	MY3B32-16B-st	st + 221 ⁺⁰ ₋₂
ø40	MY3A40-16B-st	st + 236 ⁺⁰ ₋₂	MY3B40-16B-st	st + 272 ⁺⁰ ₋₂
ø50	MY3A50-16B-st	st + 270 ⁺⁰ ₋₂	MY3B50-16B-st	st + 305 ⁺⁰ ₋₂
ø63	MY3A63-16B-st	st + 316 ⁺⁰ ₋₂	MY3B63-16B-st	st + 352 ⁺⁰ ₋₂

- e. Set the slide table in place referring to the fixing bolt position, and fix it by 4 hexagon socket head bolts.
- f. Align the end surfaces and insert them to the head cover so that the protruded amount of the dust seal band from the cylinder tube will be L dimension shown in Table 2, and fix the set screw closer to the A side holding the belt clamp.
- g. Pull the dust seal band to the B side until it has no protruded part, and fix the set screw close to the B side holding the belt clamp.
- h. Tighten the set screw closer to the cylinder tube on the top of the head cover until all of the lifted part of the dust seal band near the cylinder tube ends at both of A and B sides are eliminated.
In that case, adjust so that Dust seal band located near screws does not lift due to excessive tightening. Proper tightening torque is 0.1 N·m {1 kgf·cm}.
- i. Cycle the slide table at full stroke 2 to 3 times, and check there is no lifted part all over the dust seal band.
- j. Apply grease to the whole sliding part (top of the cylinder tube) of the dust seal band.

Note 1) Handle the dust seal band with care because it is thin and easily bent.

Note 2) Apply grease uniformly as Fig. 4. Use lithium soap grease with consistency No. 1 or No. 2.

Table 2. Dust seal band L dimension (MY3A/B)

Bore size	L dimension (mm)
ø16	11.5
ø20	14
ø25	18
ø32	20.5
ø40	25
ø50	25
ø63	29

1. Disassembly and Maintenance

Pay attention in the following points when the cylinder is disassembled for replacement of piston packing, soft wiper and wearing.

1-1. If the cylinder body or piston is removed from cylinder tube, displace the positions of external slider and piston forcedly to eliminate holding force and take out them individually.

If they are removed together with holding force left, they become unable to separate from each other by internal and external magnet force.

1-2. The used magnet has strong suction force and should be handled with care when external slider and piston slider are removed from cylinder tube.

1-3. Never disassembly the parts which compose the magnet (external slider and piston slider).

The disassembly of them may deprive holding force from the magnet and cause operating failure.

1-4. Take off the watch for handling of external slider and piston slider.

1-5. Handle external slider and piston slider with care to protect the magnet from drop on the floor and collision to the metal.

1-6. And apply the grease periodically on external face of cylinder tube.

Actuators

Modular F.R.L.
Pressure Control Equipment

Air Preparation
Equipment

Industrial Filters

Replacement
Procedure

Actuators

Modular F.R.L.
Pressure Control Equipment

Industrial Filters

1. Disassembly and Maintenance

1-1. If the cylinder needs to be disassembled for replacement of piston packing, soft wiper and wearing, specific tool is required. The specific tool can be ordered by part no. shown on Table.

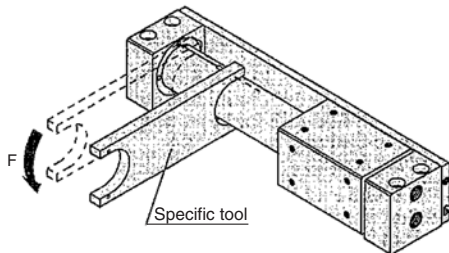

Part no. of specific tool

Part no.	Applicable cylinder tube I.D. (mm)
CYRZ-V	6, 10, 15, 20
CYRZ-W	25, 32, 40
CYRZ-X	50
CYRZ-Y	63

1-2. As for sine rodless cylinders, the cushion ring and seal are assembled to provide the optimum cushioning effect. Therefore, they should be returned to the factory for maintenance. If you disassemble them by necessity, please note the following points.

- a. If the cylinder body or piston is removed from cylinder tube, displace the positions of external slider and piston forcibly to eliminate holding force and take out them individually. If they are removed together with holding force left, they become unable to separate from each other by internal and external magnet force.
- b. Loosen hexagon socket head female on side of end cover by hexagon wrench, take off attachment ring from the end cover with specific tool and then remove the end cover from cylinder tube. After that, remove Circular stop ring mounted on the external face of the cylinder tube by snap ring pliers. The used magnet has strong suction force and should be handled with care when external slider and piston slider are removed from cylinder tube.
- c. Never disassembly the parts which compose the magnet (external slider and piston slider). The disassembly of them may deprive holding force from the magnet and cause operating failure.
- d. When handle magnet assembly, watch on your arm should be put off not to get influence from strong magnetic field.
- e. Handle external slider and piston slider with care to protect the magnet from drop on the floor and collision to the metal.
- f. And apply the grease periodically on external face of cylinder tube. The grease can be ordered by the following part no.
- g. Since the cushion ring is precisely attached to the head cover, be careful not to take it off nor deform/dent it.

1. Maintenance

When this device is disassembled to replace piston packing, wear ring and etc., care should be taken for following points.

- 1-1. To remove the external slider or the piston slider from the cylinder tube, holding force must be released by shifting positions of the external slider and the piston slider forcibly. Removing those without doing so, respective magnets call each other directly and may become impossible to separate.
- 1-2. Upon completing above works to separate respective travel parts, by loosening hexagon head cap screw (at plate A side,) remove cylinder tube and plate A from guide rod A and B. (While replacing works (of packing, so on), other parts should not be disassembled, disassembling other parts may cause to air leakage.)
- 1-3. Magnet assembly (piston slider and external slider) must not be disassembled. Disassembling this may cause to decrease of holding force and other defects.
- 1-4. Piston slider and external slider have a direction (L type and $\phi 6$, $\phi 10$)
The diagram could be referred to. Let external slider (slide lock) and piston slider contact and insert into cylinder tube to form positions shown in the diagram. When posture becomes as (b), turn only piston reverse to insert.
- 1-5. When handle magnet assembly, watch on your arm should be put off not to get influence from strong magnetic field.
- 1-6. Thorough care should be taken for the magnet not to drop on the floor or knock against metal.

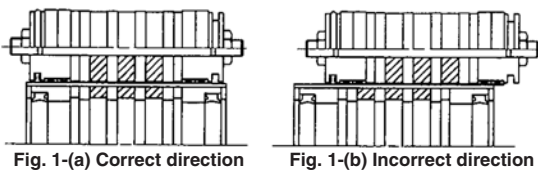

Fig. 1 Direction of the slider

2. Other Precautions

- 2-1. Parts made of iron are used in slider so care should be taken no water drops coming on the cylinder tube.
- 2-2. Grease should be periodically applied to bearing part of slide block.
- 2-3. When it is reassembled, thorough air-flashing to pipings are required not to allow dirt or cutting chips stay in side.
- 2-4. Care should be taken not to make flaw or gouge on external surface of cylinder tube and guide rod. Leaving those flaw or gouge may promote damage of scraper, wear ring and bush and thus cause to malfunction.
- 2-5. Change holding force of magnet (for an example, CY1S25L → CY1S25H) is carried out in our plant. To ask for this, please contact with our sales office.
- 2-6. Expected use under present of water (warmed water), coolant and so on, is advised to consult with us.

1. Maintenance

When this device is disassembled to replace piston packing, wearing and etc., care should be taken for following points.

- 1-1. To remove the external slider or the piston slider from the cylinder tube, holding force must be released by shifting positions of the external slider and the piston slider forcibly.
Removing those without doing so, respective magnets call each other directly and may become impossible to separate.
- 1-2. Upon completing above works to separate respective travel parts, by loosening hexagon head cap screw (at plate A side,) remove cylinder tube and plate A from guide rod A and B. (While replacing works (of packing, so on), other parts should not be disassembled, disassembling other parts may cause air leakage.)
- 1-3. Magnet assembly (piston slider and external slider) must not be disassembled. Disassembling this may cause to decrease of holding force and other defects.
- 1-4. Piston slider and external slider have a direction (L type and $\phi 6$, $\phi 10$). Refer to the fig. 1. Let external slider (slide lock) and piston contact and insert into cylinder tube to form positions shown in the fig. 1. When posture become as (b), turn only piston reverse to insert.



Fig. 1-(a) Correct direction



Fig. 1-(b) Incorrect direction

Fig. 1 Direction of the slider

- 1-5. When handle magnet assembly, watch on your arm should be put off (particularly analog one) not to get influence from strong magnetic field.
- 1-6. Through care should be taken for the magnet not to drop on the floor or knock against metal.

2. Other Precautions

- 2-1. Parts made of iron are used in slider so care should be taken no water drops coming on the cylinder tube.
- 2-2. Grease should be periodically applied to bearing part of slide block.
- 2-3. When it is installed, through air-flashing to pipings are required not to allow contaminations or chips stay inside.
- 2-4. Care should be taken not to make flaw or gouge on external surface of cylinder tube and guide rod. Leaving those flaw or gouge may promote damage of scraper, wear ring and bush and thus cause to malfunction.
- 2-5. Change holding force of magnet (for example, CY1L25L \rightarrow CY1L25H) is carried out in our plant. To ask for this, please contact with our sales office.
- 2-6. Expected use under present of water (warmed water), coolant and so on, is advised to consult with us.

⚠ Caution

1. The cross roller part which is the guide system of the Air slide table, should not be taken apart because the pre-load has been already adjusted at the mounting stage.
2. Replenishment of grease during piston packing replacement.
Apply special grease to the piston packing section and the sliding section.
(Grease No.: GR-L)

1. Replacement Procedure of Piston Seal

- 1-1. Remove hexagon socket head cap screws which connect end plate and table.
- 1-2. Remove end plate.

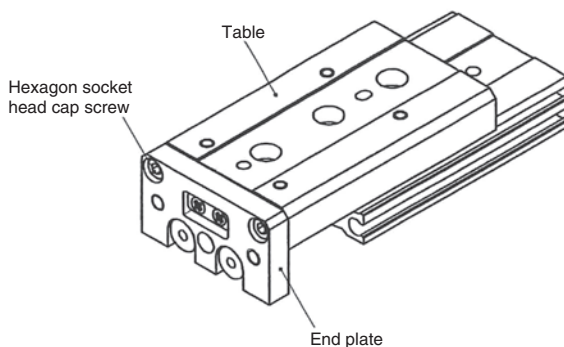

Series *MXQ*

Cautions after removing the end plate

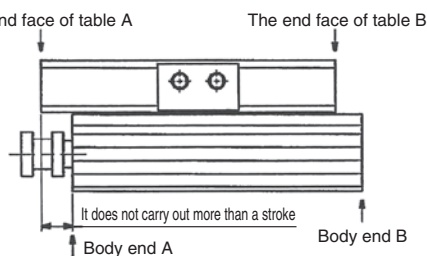

Make sure that table end A does not exceed the body end A at the full stroke after removing the end plate. Make sure that table end B does not exceed the body end B at the full stroke after removing the end plate. (The steel balls in the guide will fall out.)

- 1-3. Remove the C shaped retaining ring.
(Using a retaining ring tool)
- 1-4. Pull out piston assembly.

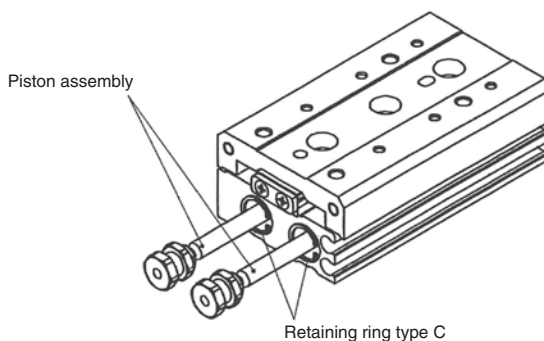

Series **MXS/MXQ/MXQR** Replacement Procedure of Seal 2

- 1-5. Apply grease to the piston seal and replace it.
- 1-6. Remove the C shaped retaining ring on the head cap side. (Use a tool for the C shaped retaining ring.)
- 1-7. Remove the head cap, apply grease and replace the O-ring.

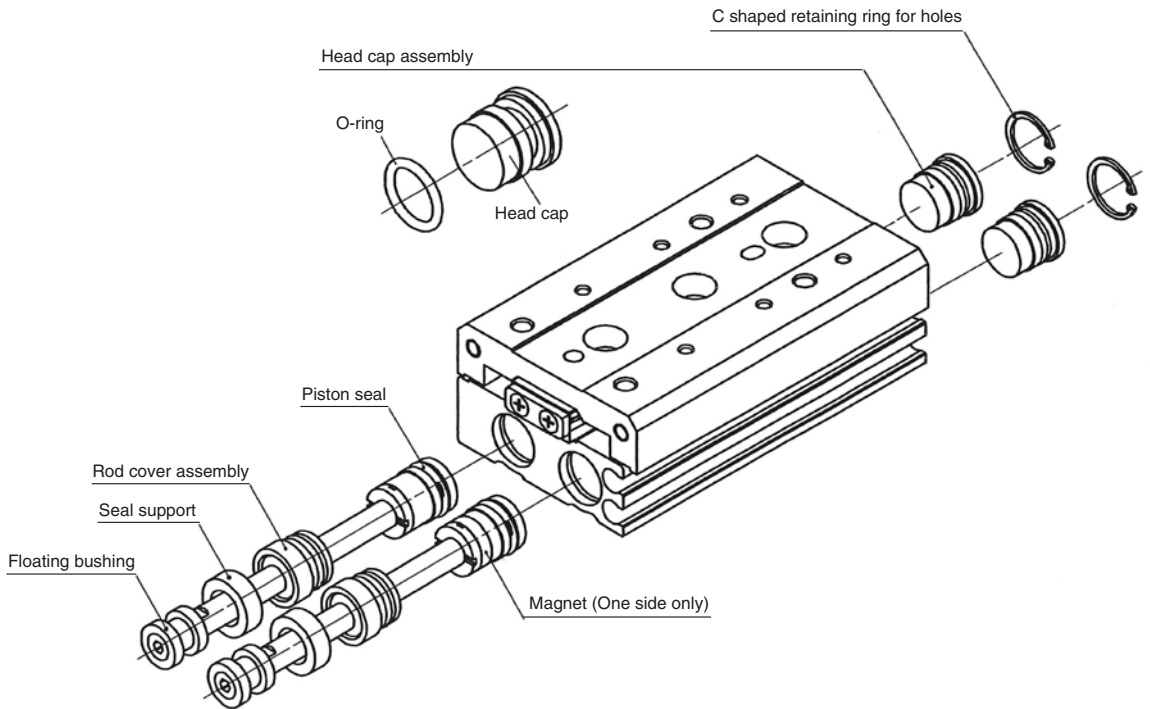

1-8. Remove the floating bushing.

ø6 and ø8 do not have width across flats. Lock onto the shaded part with Round nose chain pliers with side cutters. (It is not possible to lock onto areas other than the shaded part.)

In the case of ø12 to ø25, fix the width across flats of the rod with a wrench.

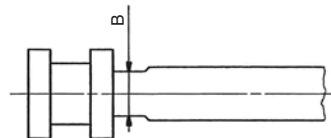
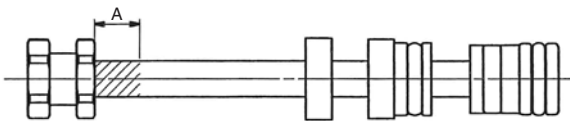

	MXS6	MXS8
Dimension A	3.2 mm or less	3.6 mm or less

	MXS12	MXS16	MXS20	MXS25
Dimension B	5 mm	6 mm	8 mm	10 mm

	MXQ6	MXQ8
Dimension A	3.2 mm or less	3.6 mm or less

	MXQ12	MXQ16	MXQ20	MXQ25
Dimension B	5 mm	6 mm	8 mm	10 mm

Series MXS/MXQ/MXQR Replacement Procedure of Seal 3

- 1-9. Remove the seal support.
- 1-10. Remove the rod cover assembly.
- 1-11. Apply grease to the O-ring and replace it.
- 1-12. Apply grease to the rod seal and replace.

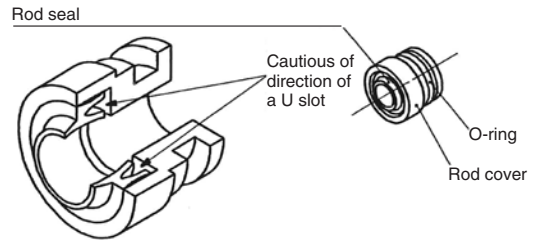

- 1-13. Mount the rod cover assembly and seal support to the piston rod assembly and insert it into the body.
- 1-14. Fix the seal support with the C shaped retaining ring. (Use a tool for retaining ring.)
- 1-15. Insert the head cap assembly into the body and fix it with the C shaped retaining ring. (Use a tool for retaining ring.)

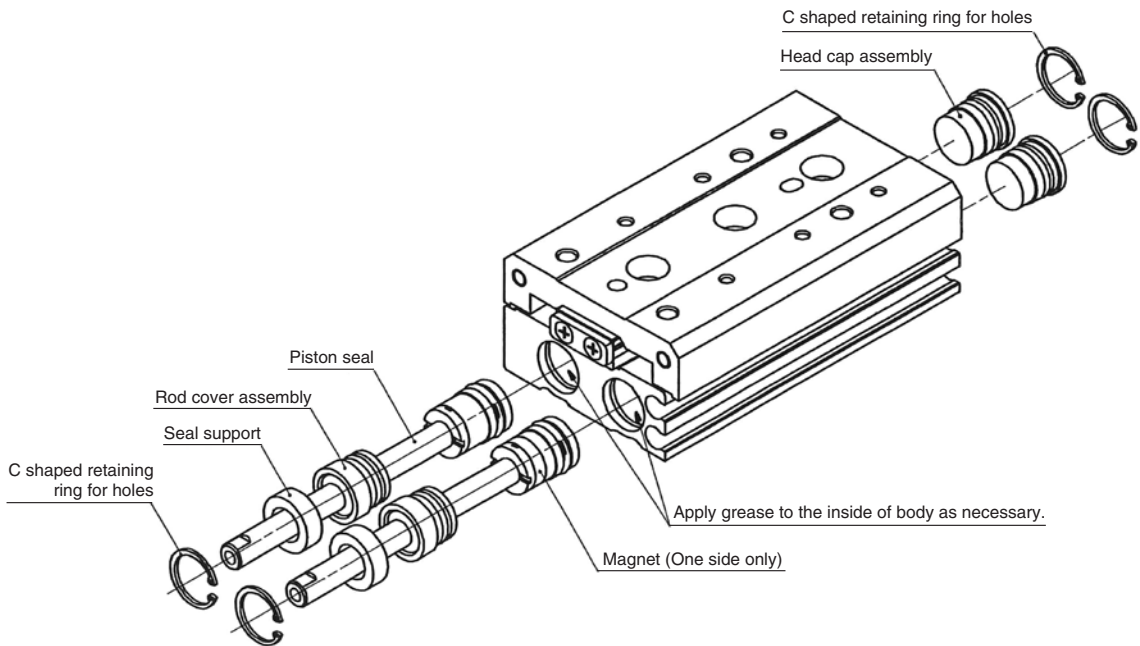

Actuators

Modular F.R.L.
Pressure Control Equipment

Air Preparation
Equipment

Industrial Filters

Replacement
Procedure

Actuators

Modular F.R.L.
Pressure Control Equipment

Industrial Filters

Series **MXS/MXQ/MXQR** Replacement Procedure of Seal 4

1-16. Mount the floating bushing onto the piston rod assembly.

ø6, ø8

Lock onto the shaded part.
Part other than shaded part cannot be caught.

Model	Dimension A
MXS6	3.2 mm or less
MXS8	3.6 mm or less

Model	Dimension A
MXQ6	3.2 mm or less
MXQ8	3.6 mm or less

Floating bushing

Model	Tightening torque (N·m)
MXS6	0.21
MXS8	0.41

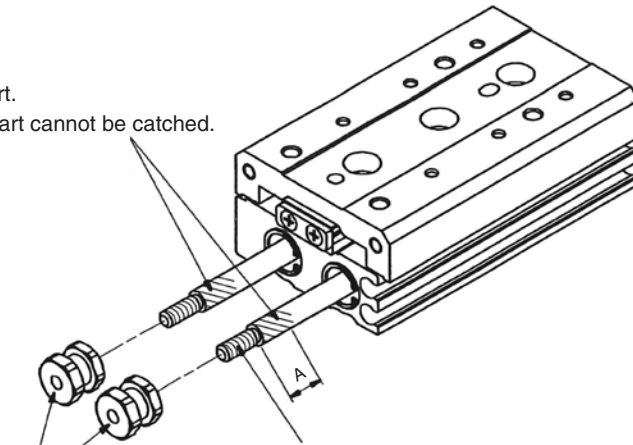

Apply Henkel Japan Loctite No.262 or an equivalent adhesive.
If adhesive is squeezed out from part A after assembly, wipe it off.

Model	Tightening torque (N·m)
MXQ6	0.21
MXQ8	0.41

ø12 to ø25

Hexagon socket countersunk head screw

Model	Hexagon socket head cap screw Fe Ni	Tightening torque (N·m)
MXS12	M3 x 14	1.0
MXS16	M4 x 18	2.4
MXS20	M5 x 20	4.3
MXS25	M6 x 25	6.9

Model	Hexagon socket head cap screw Fe Ni	Tightening torque (N·m)
MXQ12	M3 x 14	1.0
MXQ16	M4 x 18	2.4
MXQ20	M5 x 20	4.3
MXQ25	M6 x 25	6.9

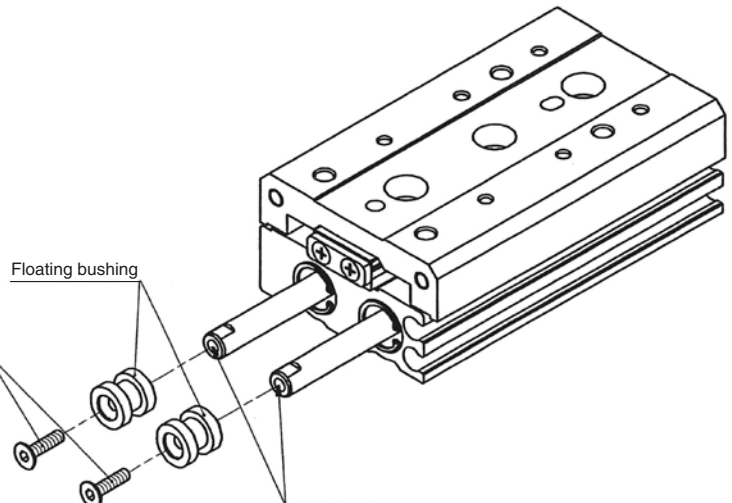

Apply Henkel Japan Loctite No.262 or an equivalent adhesive.

Series **MXS/MXQ/MXQR** Replacement Procedure of Seal 5

1-17. Mount the end plate.

1-18. Tighten the end plate mounting bolt with the specified torque.

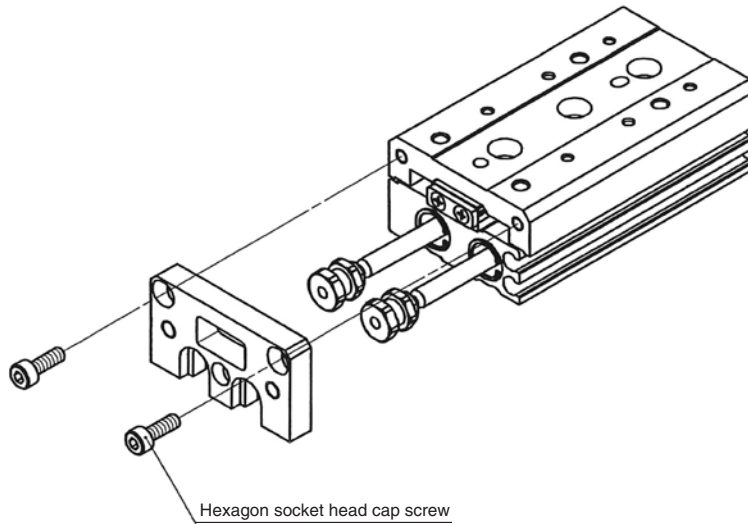

Apply Henkel Japan Loctite No.262 or an equivalent adhesive.

Model	Hexagon socket head cap screw Fe Ni	Tightening torque (N·m)
MXS6	M2.5 x 6	0.5
MXS8	M3 x 6	0.9
MXS12	M4 x 10	2.1
MXS16	M5 x 12	4.3
MXS20	M5 x 14	
MXS25	M6 x 18	6.9

Model	Hexagon socket head cap screw Fe Ni	Tightening torque (N·m)
MXQ6	M2.5 x 6	0.5
MXQ8	M3 x 6	0.9
MXQ12	M4 x 8	2.1
MXQ16	M5 x 10	4.3
MXQ20	M5 x 16	
MXQ25	M6 x 16	6.9

A level difference is set to t

No level difference with a table

Model	Level difference t mm	Model	Level difference t mm
MXS6	0.5	MXQ6	0.3
MXS8			
MXS12			
MXS16	0.3	MXQ12	0.5
MXS20	0.5	MXQ20	
MXS25		MXQ25	

Actuators

Modular F.R.L.
Pressure Control Equipment

Air Preparation
Equipment

Industrial Filters

Replacement
Procedure

Actuators

Modular F.R.L.
Pressure Control Equipment

Industrial Filters

Series *MXF* Replacement Procedure of Seal ①

⚠ Caution

The cross roller section which is the guide system of the air slide table should not be disassembled because the pre-load has been already adjusted at mounting.

1. Replacement Procedure of Piston Seal

1-1. Loosen the hexagon socket head cap screws which connect the end plate to the table.

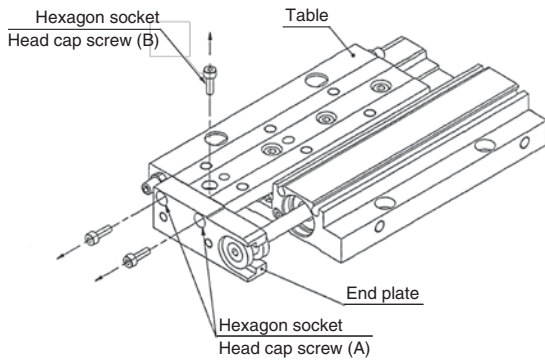

End plate attachment (A)

Model	Hexagon socket head cap screw	Tightening torque (N·m)
MXF8	M2 x 10	0.25
MXF12	M2.5 x 10	0.47
MXF16	M3 x 10	0.88
MXF20	M4 x 14	2.06

Loctite No. 242 of Henkel Japan Ltd. or its equivalent is applied.

End plate attachment (B)

Model	Hexagon socket head cap screw	Tightening torque (N·m)
MXF8	M2 x 8	0.25
MXF12	M2.5 x 8	0.47
MXF16	M3 x 10	0.88
MXF20	M4 x 14	2.06

Loctite No. 242 of Henkel Japan Ltd. or its equivalent is applied.

1-2. Move the end plate as indicated by the arrow to remove.

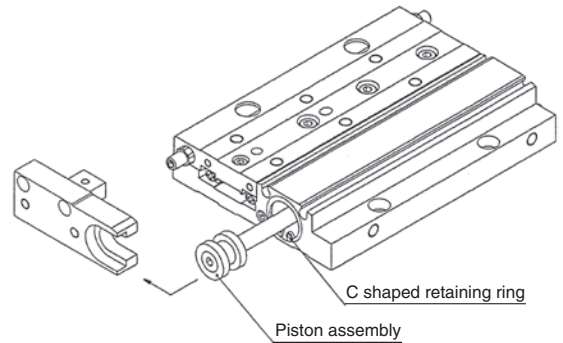

1-3. Take off the C shaped retaining ring with a tool for retaining ring.

1-4. Pull out the piston assembly.

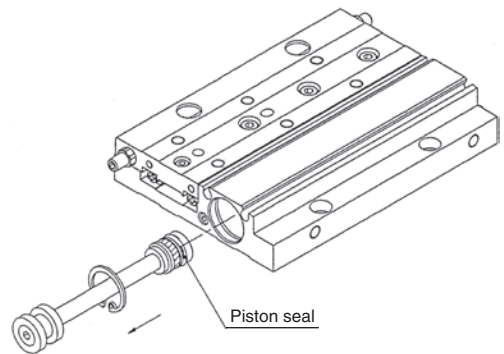

1-5. Change the piston seal.

1-6. Apply grease to the piston and the rod.

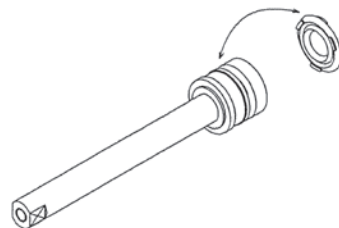

1-7. Put the piston rod, and assemble in the reverse order.

Series **MXW** Replacement Procedure of Seal 1

Caution

The linear guide section which is the guide system of the air slide table should not be disassembled because the pre-load has been already adjusted at mounting.

1. Replacement Procedure of Piston Seal

- 1-1. Remove end plate mounting bolts.
- 1-2. Remove C shaped retaining rings for end caps and head caps at first, and remove the both caps.
- 1-3. Hold the rod with a spanner, and remove the floating bushing mounting bolt.
- 1-4. Remove the end plate.

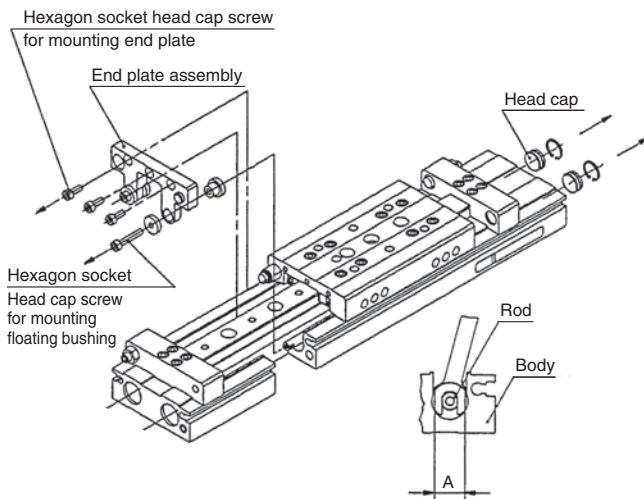

Note) The floating bushing should be mounted/dismounted carefully with a spanner whose width is A to avoid flaws inside the body.

- 1-5. Push out the piston rod with a driver less than ϕB .

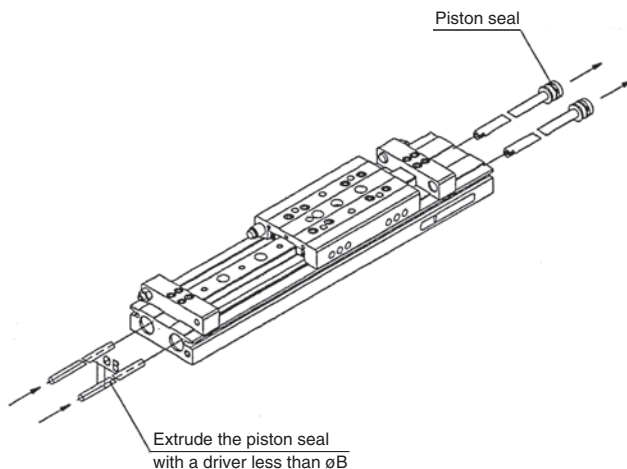

	MXW8	MXW12	MXW16	MXW20	MXW25
ϕB	3	5	7	9	11

End plate attachment

Model	Hexagon socket head cap screw	Tightening torque (N·m)
MXW8	M3 x 8	0.6
MXW12	M3 x 8	0.6
MXW16	M4 x 12	2.4
MXW20	M5 x 12	2.8
MXW25	M6 x 16	8.6

Loctite No. 242 of Henkel Japan Ltd. or its equivalent is applied.

Floating bushing attachment

Model	Hexagon socket head cap screw	Tightening torque (N·m)
MXW8	M3 x 8	0.6
MXW12	M3 x 14	1.0
MXW16	M4 x 20	2.4
MXW20	M5 x 20	5.1
MXW25	M6 x 30	8.6

Loctite No. 262 of Henkel Japan Ltd. or its equivalent is applied.

	MXW8	MXW12	MXW16	MXW20	MXW25
Dimension A	8	8.5	14.5	18	23.5
Width across flat	3.5	5	6	8	10

- 1-6. Change the piston seal.
- 1-7. Apply grease to the piston and the rod.
- 1-8. Put the piston rod, and assemble in the reverse order.

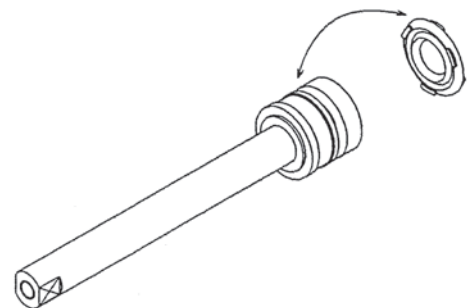

Series *MXP* Replacement Procedure of Seal 1

1. Replacement Procedure of Piston Seal

MXPJ6

- 1-1. Remove the C shaped retaining ring. (Using a retaining ring tool)
- 1-2. Remove the end cap.
- 1-3. Remove the piston.

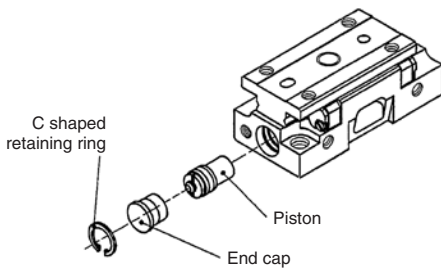

- 1-4. Apply grease to piston for replacement.



- 1-5. Apply grease to O-ring for replacement.

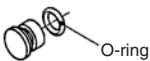

- 1-6. Apply grease to the piston surface.

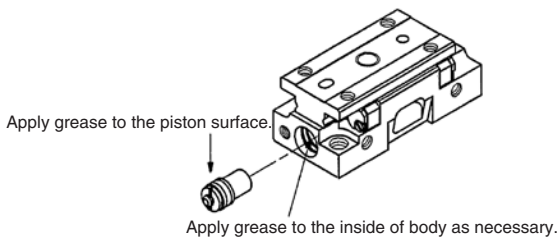

- 1-7. Insert piston and assemble parts in the reverse order of removal.

MXP6

- 1-1. Remove bolts for end plate mount.
- 1-2. Remove end plate.
- 1-3. Remove O-ring on the end plate.

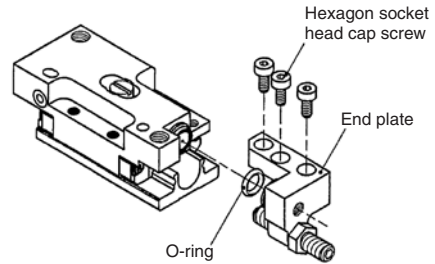

- 1-4. Remove the C shaped retaining ring. (Using a snap ring tool)
- 1-5. Remove end cap.
- 1-6. Remove piston.

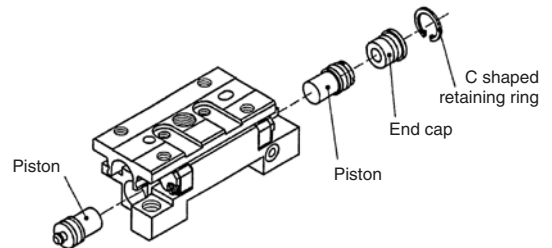

- 1-7. Apply grease to piston for replacement.



- 1-8. Apply grease to O-ring for replacement.

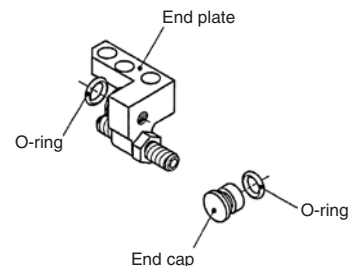

Series MXP Replacement Procedure of Seal 2

1-9. Apply grease to the piston surface.

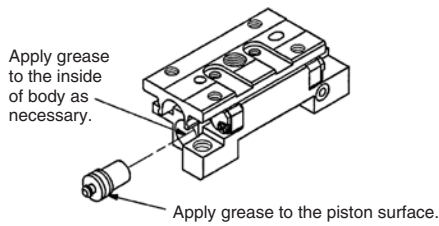

1-10. Insert the piston, and assembly in the reverse order.

Note) Tighten the end plate mounting bolt with the specified torque.

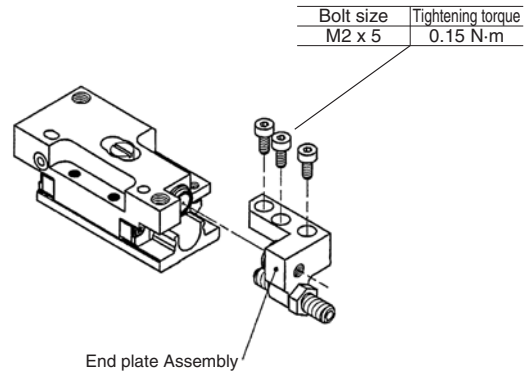

No gap is present at the mating surface between the body assemblies.

MXP8, 10, 12, 16

1. Remove bolts for end plate mount.
2. Remove end plate.
3. Remove the tube and O-ring.
4. Apply grease to the O-ring and replace it.
5. Remove the joint shaft. Remove the piston assembly from the body.
6. Apply grease to the piston seal and replace it.

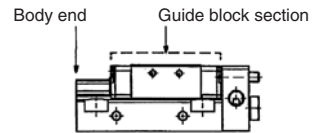

Make sure that the guide block will not exceed the body end surface after removing the joint shaft. (The steel balls in the guide will fall out.)

Type	Width across flates
MXP8	
MXP10	2.5 mm
MXP12	
MXP16	3 mm

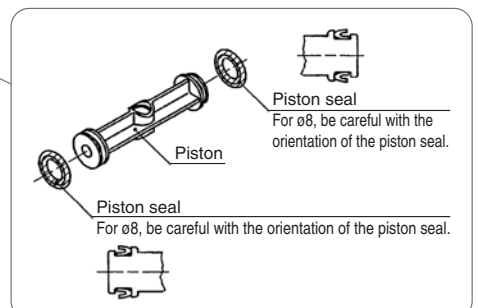
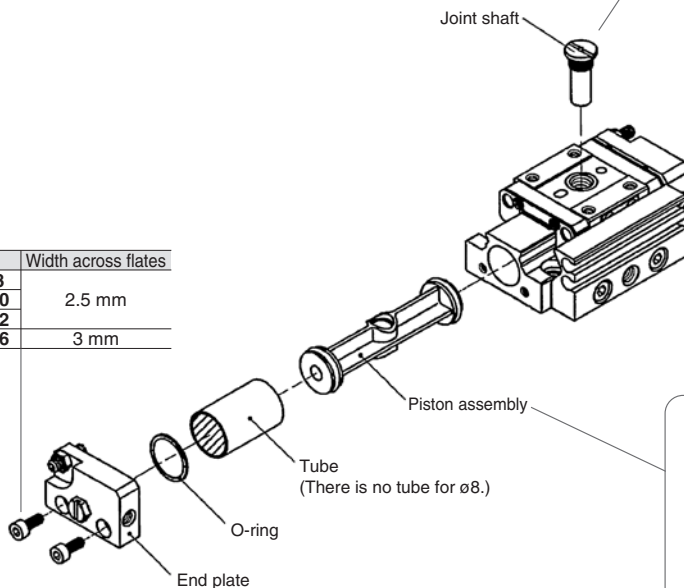

Series MXP Replacement Procedure of Seal 3

7. Insert the piston assembly to the body, and tighten the body with the joint shaft.
8. Apply grease to the shaded part of the tube inner surface if necessary. (See the drawing of previous page)
9. Mount the tube and O-ring.
10. Mount end plate.
11. Fasten bolts for end plate mount with specified torque.

Note 1) Assemble end plate so that A, B dimensions will be values on table below.

Type	Tightening torque joint shaft
MXP8	0.4 N·m
MXP10	0.7 N·m
MXP12	1.8 N·m
MXP16	3.6 N·m

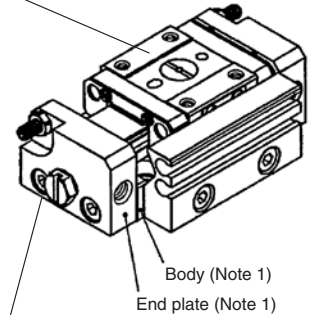

Type	Bolt torque
MXP8	0.45 N·m
MXP10	0.6 N·m
MXP12	1.4 N·m
MXP16	1.4 N·m

(mm)		
Type	A	B
MXP8	0.2	0.2
MXP10	0.2	0.2
MXP12	0.5	0.3
MXP16	0.5	0.3

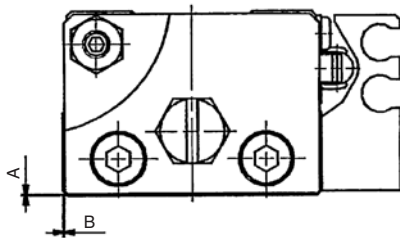

12. Remove the end plate mounting bolt on the opposite side.
13. Remove the end plate on the opposite side.
14. Remove the tube and O-ring.
15. Apply grease to the O-ring and replace it.
16. Apply grease to the shaded part of the tube inner surface if necessary.
17. Mount the tube and O-ring.
18. Mount the end plate on the opposite side. (*2)
19. Tighten the end plate mounting bolt on the opposite side with the specified torque.

Note 2) Assemble end plate so that A, B dimensions will be values on table below. (As well as *1)

(mm)		
Type	A	B
MXP8	0.2	0.2
MXP10	0.2	0.2
MXP12	0.5	0.3
MXP16	0.5	0.3

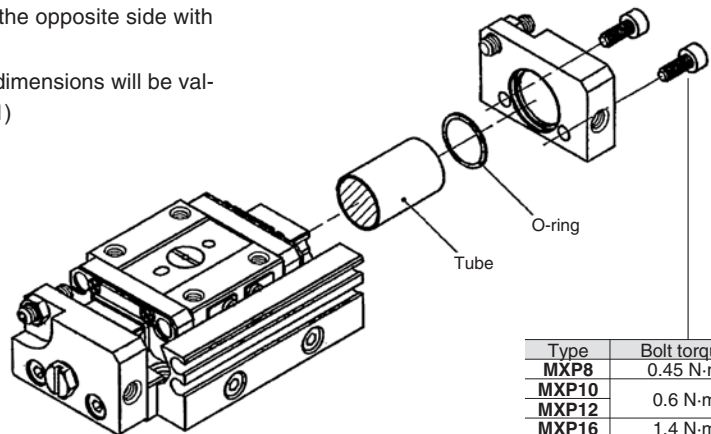
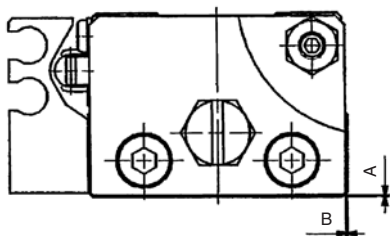

Type	Bolt torque
MXP8	0.45 N·m
MXP10	0.6 N·m
MXP12	1.4 N·m
MXP16	1.4 N·m

Series *MX* Replacement Procedure of Seal ①

1. Disassembly Procedure (Seal and Wearing)

1-1. a. Remove guide block fixing studs.

Note) Take care so that guide block would not come off even partially to prevent steel ball of guide block from coming out and becoming unavailable.

- b. Loosen switch rail fixing studs and disconnect switch rail.
- c. Loosen end plate fixing hexagon socket head cap screws and disconnect end plate.
- d. Disconnect cylinder assembly.

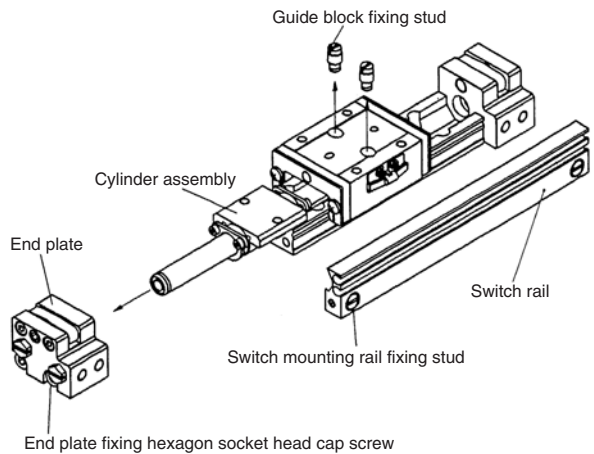

1-2. a. Take off end cap from tube of cylinder assembly.

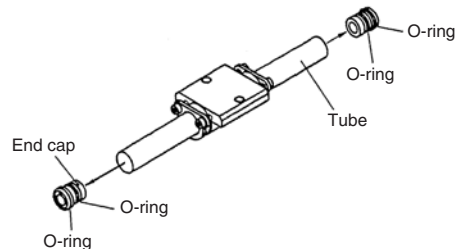

1-3. a. Insert round bar jig into tube and hold piston slider.

Note) Do not damage internal face of tube at this time.

- b. Move external slider forcedly to make holding force unable to act.
- c. Take off piston slider from tube.
- d. Take off external slider from tube.

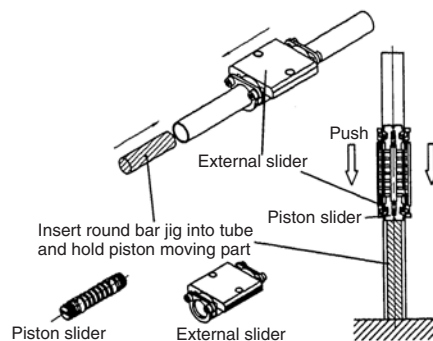

1-4. a. Loosen hexagon socket head bolts on both end faces of body and disconnect spacer.

Note) Take care so that magnet B and yoke B would not come out.

- b. Take off wearing B and cylinder scraper from spacer and replace each with new one.

Note) Mind mounting direction of cylinder scraper.

- c. Tighten hexagon socket head cap screws on right end face with referential mark on body turned front until spacer is made close to body tightly.
- d. Tighten hexagon socket head cap screws on left end face with referential mark on body turned front until spacer is mounted on body with clearance.

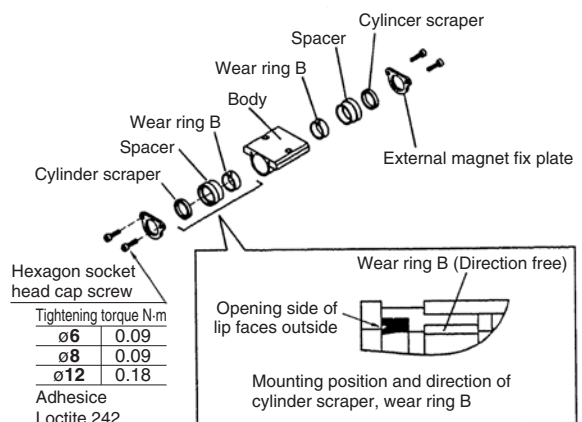

Actuators

Modular F.R.L.
Pressure Control Equipment

Air Preparation
Equipment

Industrial Filters

Replacement
Procedure

Actuators

Modular F.R.L.
Pressure Control Equipment

Industrial Filters

Series *MX* Replacement Procedure of Seal 2

Note) Tighten each two hexagon socket head cap screws by turn gradually until specified torque is reached to make force given to them even.

Note) Before tightening, apply specified adhesive (Loctite 242 or equivalent) on hexagon socket head cap screws.

- 1-5. a. Holding one piston by flat blade screw driver, loose the other piston by flat blade screw driver.
- b. Take off yoke A and magnet A from shaft. Magnet A should be kept with stick inserted.
- Note) Mounting direction of magnet A is specified. So, keep them in the manner like above not to be unable to recognize correct mounting direction.
- c. Take off wearing A and piston seal and replace each with new one.
- Note) Mind mounting direction of piston seal in MX6 and MX8.
- Note) Apply specified grease (Grease pack: GR-S-* or equivalent) on wearing A and piston seal.
- Note) Confirm piston seal is mounted without twist.
- Note) Piston seal is mounted only on one side in MX12.
- d. Insert yoke A and magnet A into shaft the reverse procedure.
- e. Tighten piston to shaft by torque specified on right figure.
- Note) Apply specified adhesive (Loctite 262 or equivalent) on the end of shaft.

Caution on mounting external slider

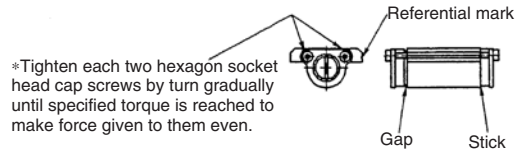

Tighten the bolt with comes right when referential mark is turned front. (Gap is created between left spacer and body.)

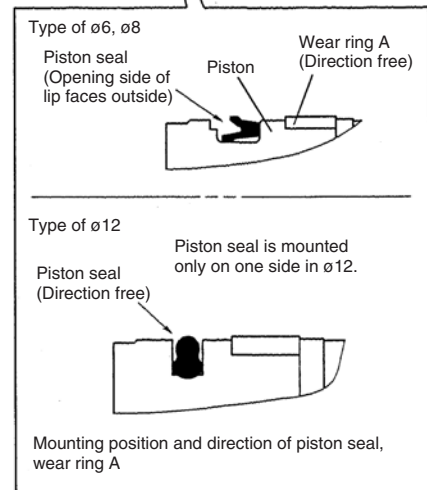
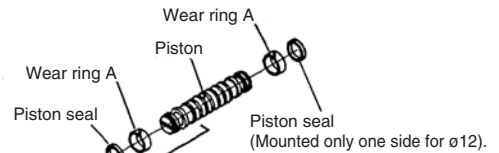

Tightening torque N·m	
ø6	0.09
ø8	0.09
ø12	0.18

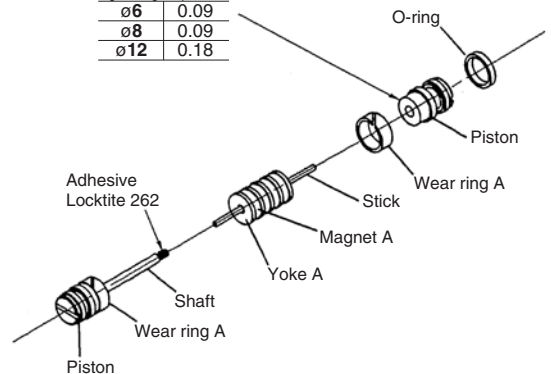

How to remove Yoke A and Magnet A

Series MXY Replacement Procedure of Seal 3

- 1-6. a. Apply grease all around piston slider.
- b. Apply grease all around internal face of external slider.
- c. Insert piston moving part and external slider into tube.
- d. Move external moving part to a little over stroke end manually to engage it with piston slider (i. e. to locate magnet coupling on adequate position.)
- e. Apply grease evenly on internal and external face of tube.

Note) Do not close external slider to the end of tube to apply the grease because all of grease is brought to there during operation.

Note) Use specified one (Grease pack: GR-S* or equivalent) for grease.

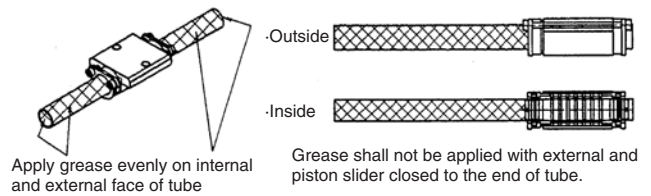
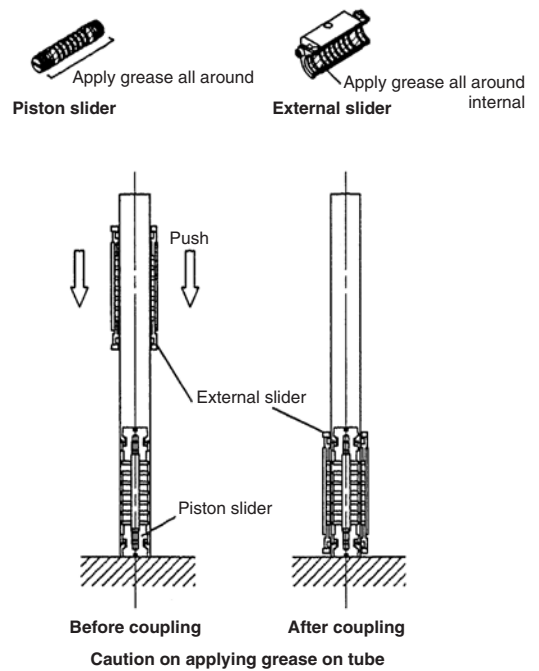

- 1-7. Put end cap in tube.

Note) Ensure O-ring doesn't come off.

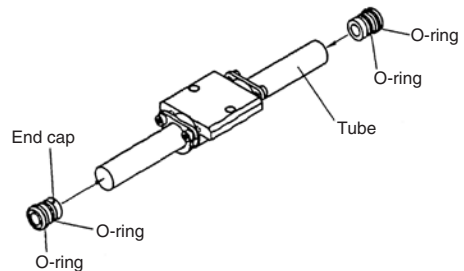

Actuators

Modular F.R.L.
Pressure Control Equipment

Air Preparation
Equipment

Industrial Filters

Replacement
Procedure

Actuators

Modular F.R.L.
Pressure Control Equipment

Industrial Filters

Series MXY Replacement Procedure of Seal 4

1-8. a. Tighten end plate on left side to rail temporarily with referential mark on guide block turned to front (with port bore turned to front as well).

Note) Apply specified adhesive (Loctite 242 or equivalent) on end plate holding hexagon socket head cap screws.

b. Pass cylinder assembly between rail and guide block with referential mark on cylinder assembly turned to front and then tighten end plate on right side temporarily like one on left side.

c. Tighten guide block holding stud by torque specified on right figure to hold guide block to external slider.

Note) Apply specified grease (Grease pack: GR-S-* or equivalent) on the side of guide block fixing stud except for threaded part.

d. Tighten end plate fixing hexagon socket head cap screw by torque specified on right figure.

e. Tighten switch rail holding stud by torque specified on right figure to hold switch rail to end plate.

Note) Keep step among end plate, switch rail and rail within the value shown on right figure.

Note) Ensure switch rail doesn't contact magnet by moving guide block all over its movable part.

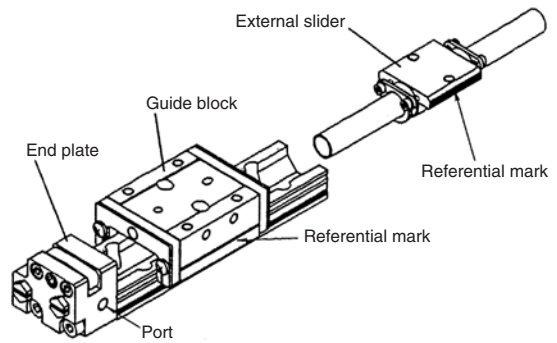

Guide block fixing stud

Tightening torque N-m	
φ6	0.32
φ8	0.76
φ12	2.6

Adhesive
Loctite 242

End plate fixing hexagon socket head bolt

Tightening torque N-m	
φ6	0.63
φ8	1.5
φ12	3

Adhesive
Loctite 242

Switch rail fixing stud
Tightening torque
0.7 N-m

Step between end plate and rail shall comply with table.

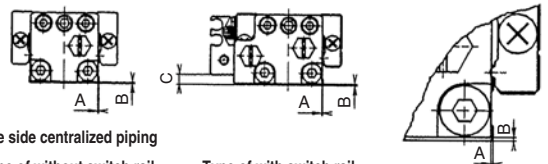

One side centralized piping

Type of without switch rail

Type of with switch rail

Detail of dimension A and B

Model	A	B	C
MXV6	0.3	0.3	0.5
MXV8	0.3	0.5	3.5
MXV12	0.3	0.5	8.5

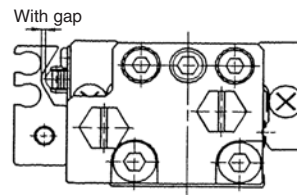

⚠ Caution

Cylinder needs to be disassembled/assembled at clean environment. Use a clean cloth.
Before disassembly, eliminate the dirt on the outer surface so that foreign material does not enter the cylinder or the guide.

1. Disassembly

1-1. Tools

Retaining ring plier for hole, hexagon wrench, spanner, socket wrench (or air impact wrench).

1-2. Fix the piston rod so that it is not scratched. Remove the guide rod assembly by loosening the plate mounting bolt with a hexagon wrench or socket wrench.

Or, loosen the plate set bolt with the air impact wrench to remove the guide rod assembly.

Continue the work without removing the guide rod from the plate.

1-3. Remove the two retaining rings (rod and head side) with the retaining ring pliers, and pull out the collar, head cover and piston rod assembly.

For air cushion type and end lock type, it is necessary to remove the collar and parts below.

Air cushion type (ø80, ø100)

- Set screw at the bottom of the cylinder.

End lock type

- End lock unit (See below)

Bore size (mm)	Retaining ring size	Width across flat (mm)	Plate mount bolt tightening torque (kgf·cm)
12	RTW-13	5	14
16	RTW-18	6	34
20	RTW-22	8	52
25	RTW-26	10	88
32	RTW-34	14	220
40	RTW-42	14	220
50	RTW-52	17	440
63	RTW-65	17	440
80	RTW-82	22	1,240
100	RTW-102	27	2,000

Removal of End Lock (With End Lock)

1. Tools

Retaining ring plier for hole, hexagon wrench, spanner, socket wrench (or air impact wrench), watchmakers screw driver.

2. Insert the manual bolt from the top of the end lock unit rubber cap, and screw the bolt into the lock piston, (Not necessary for -*L, lock tyoe)

3. Remove two hexagon socket head cap screws to pull out the end lock unit.

4. For ø20 to ø63, remove the lock piston seal.

For ø80, ø100, remove the packing seal retainer and locking piston seal.

5. Remove the lock holder mounting bolt to remove the lock unit and gasket.

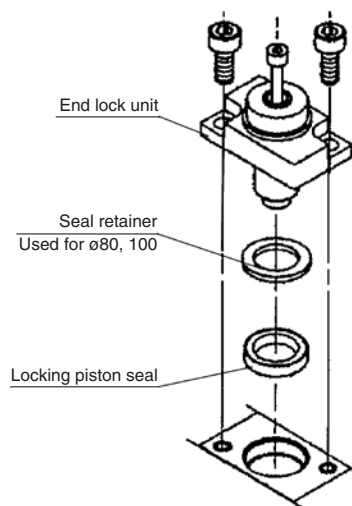

Fig. 1 How to remove the end lock

2. Removal of the Seal

2-1. Rod seal

a. Tools

Watchmakers screw driver, etc.

b. Insert the driver to the collar front to pull out the seal like Fig. 2.

Do not damage the seal groove on the collar at this time.

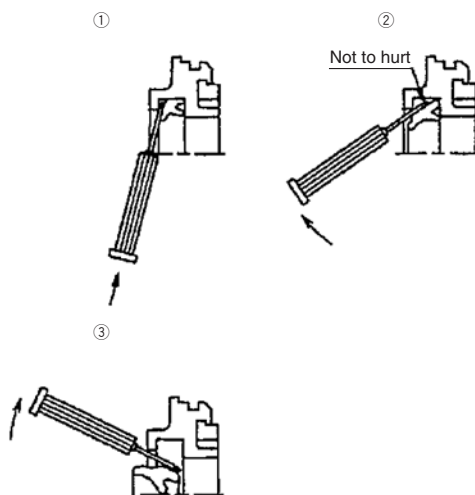

Fig. 2 How to remove rod seal

Actuators

Modular F.R.L.
Pressure Control Equipment

Air Preparation
Equipment

Industrial Filters

Replacement
Procedure

Actuators

Modular F.R.L.
Pressure Control Equipment

Industrial Filters

2-2. Piston seal

Wipe off grease around piston seal first to make removal easier.

Hold piston seal with one hand and push it into groove so that piston seal can be lifted off and pulled out without using a watchmakers screw driver. (Fig. 3)

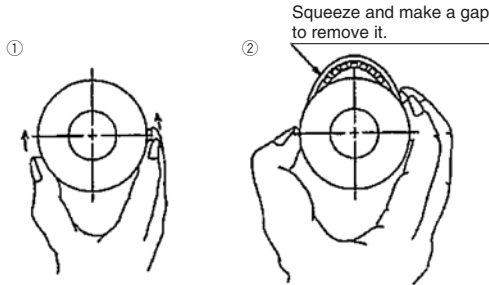

Fig. 3 How to remove piston seal

2-3. Gasket

Pull out the collar and the head cover outer rim or the gasket inside of the body ($\phi 32$ or larger) with precision driver.

2-4. Cushion seal (With air cushion only)

- a. Tool: Watchmakers screw driver, etc.
- b. As shown in Fig.4, pull out the cushion seal by inserting the precision screwdriver from the back of the seal and the head cover. Take care not to damage the seal groove at this time.

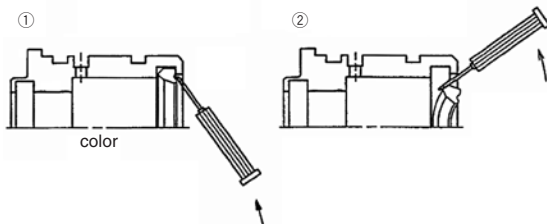

Fig. 4 Removing the cushion seal

3. Application of Grease

Use grease pack in table or lithium soap base grease JIS2, or equivalent.

Table Grease pack no.

10 g type	GR-S-010
20 g type	GR-S-020

3-1. Rod seal

Apply grease slightly to outer circumference of new seal for replace. This helps the seal to accustom to the collar. For the groove, fill it with grease. This is necessary for operation.

Outer circumference grease



Fig. 4

3-2. Piston seal

Apply grease to outer/inner circumference of seal slightly and evenly to make mounting this to the piston easier.

3-3. Gasket

Apply grease slightly. Provide better sealing and stop falling.

3-4. Cushion seal (With air cushion only)

Apply grease to outer/inner circumference of seal slightly and evenly to make mounting this to the seal groove.

3-5. Cylinder parts

Apply grease to cylinder parts including the guide.

With end Lock

Use lithium soap radical grease JIS2 corresponding to such as "Nippon Oil Corporation multipurpose grease No. 2", "Idemitsu Daphne coronex No. 2", "Kyoseki lisonix grease No. 2".

4. Assembly

4-1. Mount seal

a. Rod seal

Mind the seal direction. Apply grease all over the seal and inner surface of the bush as Fig. 8. You may use a precision screw driver to apply grease when small bore diameter.

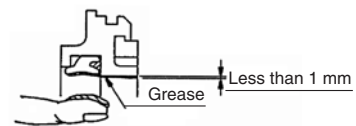

Fig. 8 Rod seal

b. Piston seal

Apply grease rubbing to seal groove and outer circumference.



Fig. 9 Piston seal

c. Gasket (With rubber bumper)

Mount to the groove of the collar and the head cover. For $\phi 32$ or larger, mount to the inner groove of the body, not to the head cover.

This case, the gasket of the body is large type.

d. Gasket (With air cushion)

Mount to the groove of the collar and the head cover. For $\phi 32$ or larger, mount to the inner groove of the head cover and the body.

This case, the gasket of the body is large type.

Do not mount the gasket on the air passage (through hole groove) as in Fig.10.

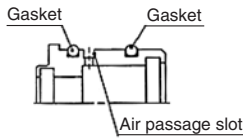

Fig. 10 Gasket mounting position

e. Cushion seal (With air cushion only)

Mount the seal in the correct direction. Apply grease thinly and evenly to the inner circumference of the seal. As the seal has a floating mechanism, it is normal to have some play.

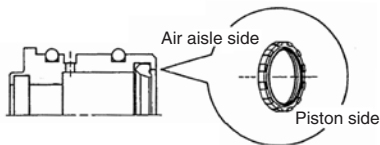

Fig. 11 Cushion seal mounting position

4-2. Assemble cylinder

a. Insert the head cover to the body to fix with a retaining ring.

b. Insert the collar to the piston rod.

Apply grease to the piston rod end or 30 degree of slope at the end of spanner flat, and insert the collar gently so that the piston seal is not hurt.

c. Insert the piston and the collar to the tube and fix it with a retaining ring.

Apply grease to the inlet of the tube and insert the piston and the collar gently so that the piston seal and the gasket are not hurt by the retaining ring groove.

d. Guide rod assembly assembling

Apply glue to the plate mounting bolt when mounting the guide rod assembly. Then tighten the bolt with tightening torque in table 1.

After assembling, ensure manually that work properly operate smoothly.

Check the air leakage.

With End Lock

1. Mount end lock

Apply grease to the lock piston surface, lock holder inner surface to insert the gasket and lock holder. Then, fix them with new hexagon socket head cap screws included in accessories.

Insert the end lock unit and fix it with new hexagon socket head cap screws included in accessories. (See drawing 12, 13, 14, 15)

After assembling, ensure manually that end lock work properly and cylinder operate smoothly with lock released.

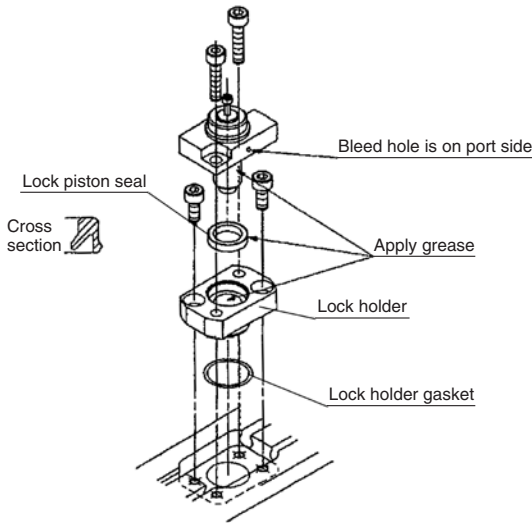

Fig. 12 End lock reassembled ($\phi 20, \phi 25$)

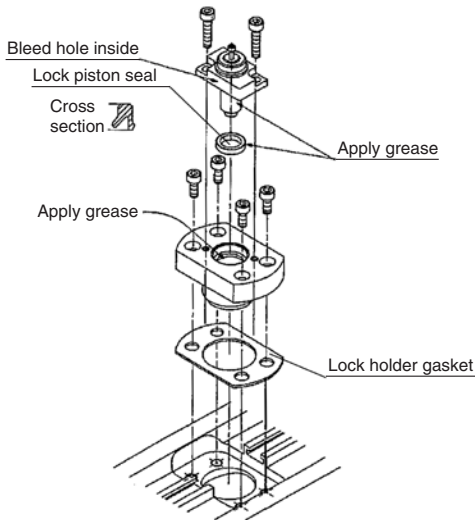

Fig. 14 End lock reassembled ($\phi 50, \phi 63$)

Cap and lock holder bolt tightening torque

Hexagonal bolt	Bore size (mm)	Tightening torque (N)
M3	$\phi 20$ to $\phi 63$	0.71 to 0.86
M5	$\phi 80, \phi 100$	2.65 to 3.24

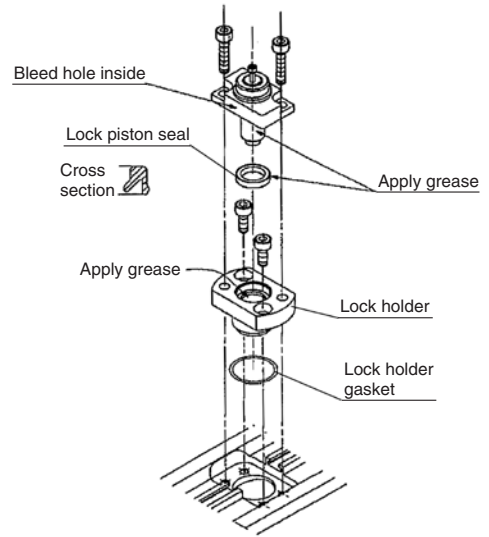

Fig. 13 End lock reassembled ($\phi 21, \phi 40$)

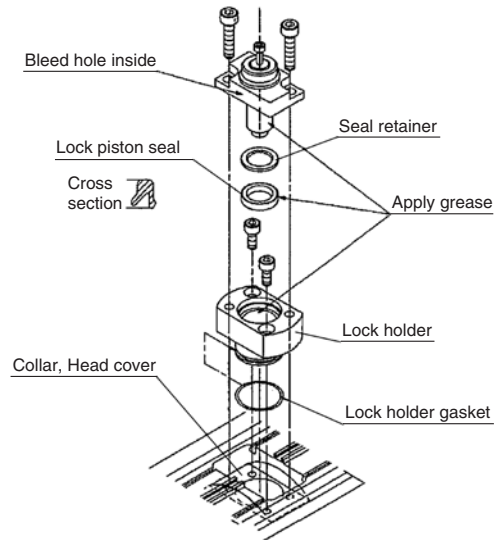

Fig. 15 End lock reassembled ($\phi 80, \phi 100$)

⚠ Caution

Replace the hexagon socket head bolt with a new one included in the packing set to avoid air leakage.

Tighten the hexagon socket head bolt evenly to avoid air leakage.

Series MGF Replacement Procedure of Seal 1

⚠ Caution

Disassemble and assemble the cylinder in a clean area. Remove dusts and foreign matters from external surfaces to prevent them from entering the cylinder during disassembly. Perform on a clean cloth.

1. Maintenance

- 1-1. When malfunction of cylinder occurs due to air leakage, replace seal and gasket by referring to procedure shown below.
- 1-2. Replacement procedure
 - a. Remove two hexagon head bolts C 14 and separate upper and lower assemblies.
 - b. Remove six hexagon head bolts A 12 of the upper assembly and remove plate 6.
 - c. Push piston rod assembly (piston rod 5 + piston 4) from rod seal side to pull the piston rod out of tube 2.
 - d. Remove piston seal 20 from piston 4 and replace it by new one. Apply grease on the overall surface of piston seal.
 - e. Remove rod seal 19 from rod cover 3 and replace it by new one. Care should be taken for the orientation of rod seal. Mount it by referring to the internal structural drawing.
 - f. Remove four hexagon head bolts B 13 and separate body 1 and end plate 7.

3. Disassembly

- 3-1. Separation of upper assembly from lower assembly

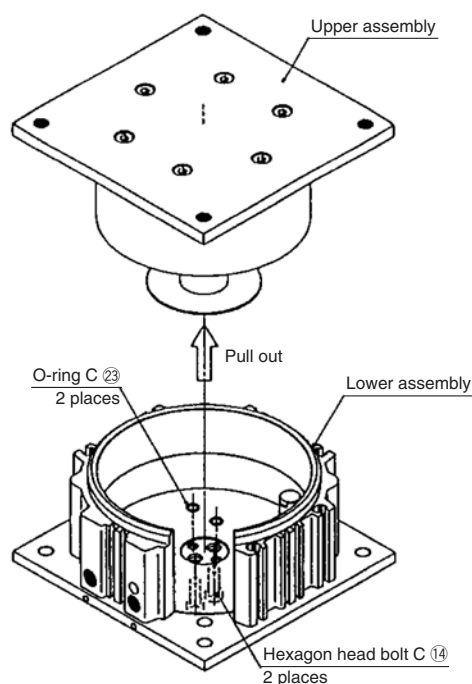

- g. Remove two O-rings C 23 on the end plate side and replace them. Apply grease on the overall surface of gasket.
- h. Remove O-ring B 22 from tube 2 and replace it. Apply grease on the overall surface of gasket.
- i. After all replacement is completed, reassemble the parts. To assemble, follow the disassembling procedure a to h in reverse order.

2. Caution at Assembly and Disassembly

- 2-1. Adhesive is applied to each bolt to prevent loosening. Since powders (adhesive) come out when bolt is removed, care should be taken to prevent them from entering cylinder and sliding part.
- 2-2. Apply the adhesive (moderate strength) to each bolt at assembling.
- 2-3. When the upper assembly is inserted to the lower assembly, bush in the lower assembly is not complete round. Therefore, press the bush by the tube of the upper assembly so that the bush becomes complete round. Care should be taken not to break the bush since broken bush will cause malfunction.
- 2-4. Insert the piston rod assembly to the same position as it was disassembled.
If the piston rod assembly is rotated, lifting and lowering ports would be reversed.

Series MGF Replacement Procedure of Seal 2

3-2. Disassembly of upper assembly

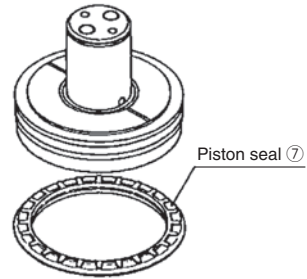
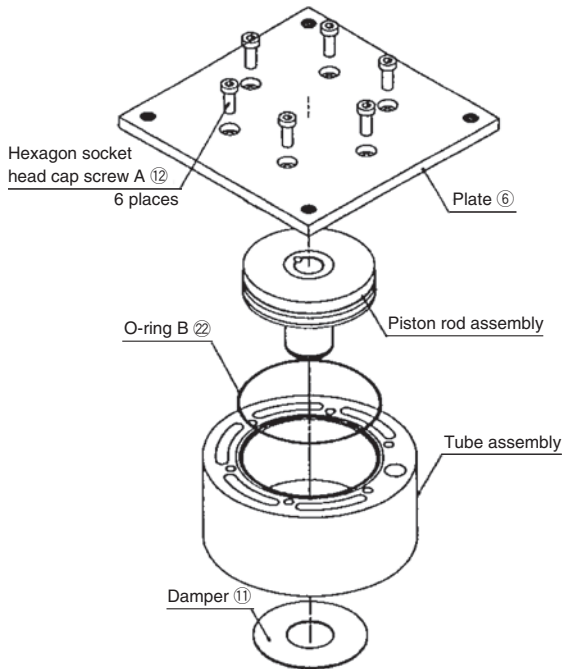

Replacement of Piston Seal

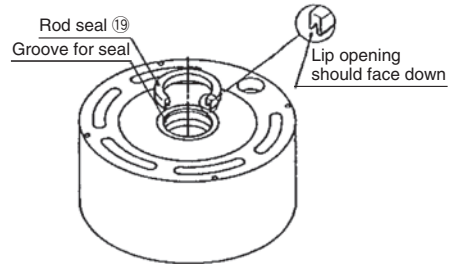

Replacement of Rod Seal

3-3. Disassembly of lower assembly

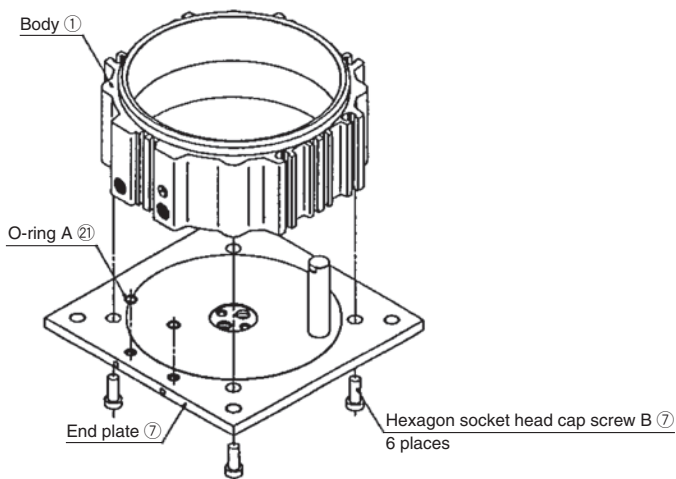

1. Disassembly

⚠ Caution

It decomposes and it is necessary to assemble the cylinder in a clean place.
Please begin working after it wipes off with a clean cloth, etc.

1-1. Loosen and remove the hexagon socket head cap screw and set screw which fix plate, rod. Then pull the plate out of the rod.

At this occasion, screws are sometime hard to unscrew because they are applied Loctite. Pay attention not to damage the hexagon head.

As plates are sometime hard to unscrew as well, use a gear-puller not to damage rods.

Series CXS

With end lock

1-2. Detach the lock unit (5 to 10) from the housing.

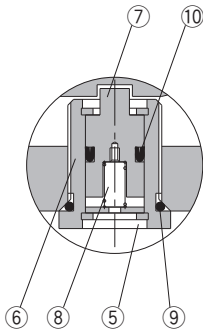

Fig. 1

1-3. Detach retaining rings on the side of head cover using pliers (tool for basic internal retaining ring).

1-4. Hit rods lightly with a plastic hammer, then pull them out from head cover side. At this occasion, they go through bearing part, so make sure there are no burrs or deformation. Burrs or deformations have to be removed by a file or sandpaper.

1-5. Detach the retaining rings on the side of rod cover by using pliers (tool for basic internal retaining ring), then the rod cover away in the same method of 1-4.

1-6. Reusing of packing is not possible. They have to be replaced by the new one at the occasion of reassembling.

At this time, grease has to be applied to packings and kept away from the dust.

Series CXS

With end lock

1-7. O-ring and Lock seal is exchanged. The lock seal removes and exchanges the snap ring.

Reusing of packing is not possible. They have to be replaced by the new one at the occasion of reassembling.

2. Assembly

2-1. Reassemble the parts by reversing the disassembling process.

2-2. Mount the plate to the rod.

It is necessary for the rod to be in the extend state. Apply 0.2 MPa or more from the supply port of the head cover side. Tighten the hexagon socket head cap screw pressing the plate to the rod. Then, tighten the hexagon socket head set screw.

Make sure the product operates with the minimum operating pressure (see table below) without any problem. (The product operates smoothly when it is moved by hand)

Bore size (mm)	6	10	15	20	25	32
Minimum operating pressure (MPa)	0.15	0.1			0.05	

Series CXS

With end lock

After tightening, make sure there is no problem when it is operated in minimum operation pressure (See below) and confirm the lock on the return side.

Bore size (mm)	6	10	15	20	25	32
Minimum operating pressure (MPa)				0.3		

Actuators

Modular F.R.L.
Pressure Control Equipment

Air Preparation
Equipment

Industrial Filters

Replacement
Procedure

Actuators

Modular F.R.L.
Pressure Control Equipment

Industrial Filters

Series **CLG1** Replacement Procedure of Seal 1

1. Disassembly of the Cylinder

1-1. The cylinder needs to be disassembled and assembled in a clean place.

1-2. Refer to the "Replacement Procedure of the Lock Unit" (CLG-1) ① to ③ for disassembly.

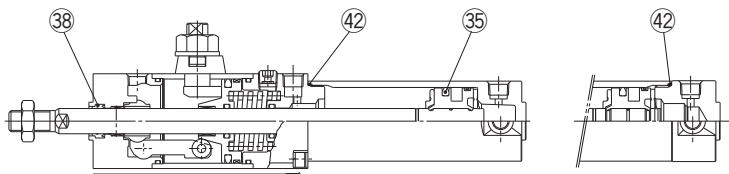

Long stroke

- ③8 Rod seal A
- ③5 Piston seal
- ④2 Cylinder tube gasket

2. Removal of the Seal

③8 Rod seal A: Insert a watchmakers screw driver to pull out the seal.

Take care not to damage the seal groove of the cover. (Fig. 1)

③5 Piston seal: Remove the piston seal. (Fig. 2)

④2 Cylinder tube gasket: Insert a watchmakers screw driver to pull out the seal.

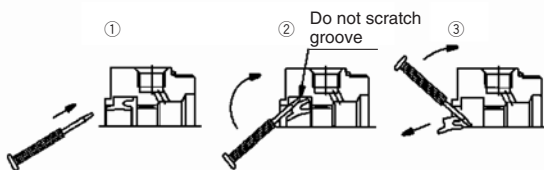

Fig. 1 Removal of rod seal

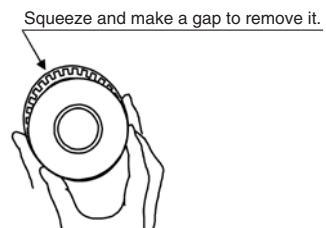

Fig. 2 Removal of piston seal

3. Application of Grease to Seal

3-1. Apply grease slightly to the outer circumference of each seal.

3-2. Fill in the groove of the rod seal with grease.

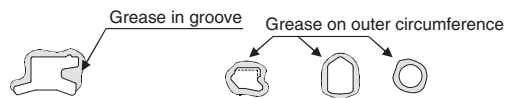

Fig. 3 Grease to the seals

4. Mounting of Seal

③8 Rod seal A: Mount the seal in the correct direction.

③5 Piston seal: Mount the seal while stretching it as Fig. 5.

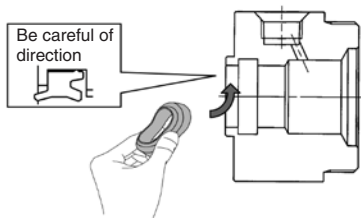

Fig. 4 Installation of rod seal

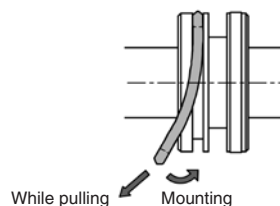

Fig. 5 Installation of piston seal

5. Application of Grease

- ③⑧ Rod seal B: Apply grease to the seal and the inner circumference of the bush. (Fig. 6)
Use a precision screwdriver to apply grease to the small bore diameter while making sure not to leave scratches.
- ③⑤ Piston seal: Rub grease into the seal groove and outer circumference of the seal. (Fig. 7)
- ④② Cylinder tube gasket: Lightly apply grease.
- Cylinder component parts: Apply grease to each component parts of the cylinder in Figure 9.
Appendix table shows the grease amount required for a cylinder with stroke 100.
For your reference, amount taken with a forefinger is about 3 g. (Fig. 8)

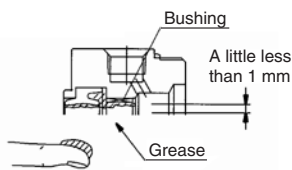

Fig. 6 Rod seal

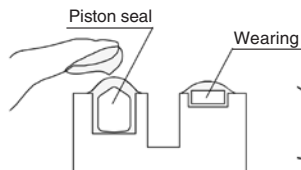

Fig. 7 Piston seal

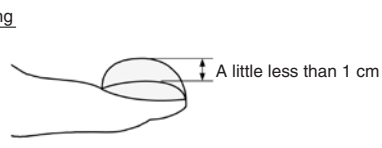

Fig. 8 Grease amount

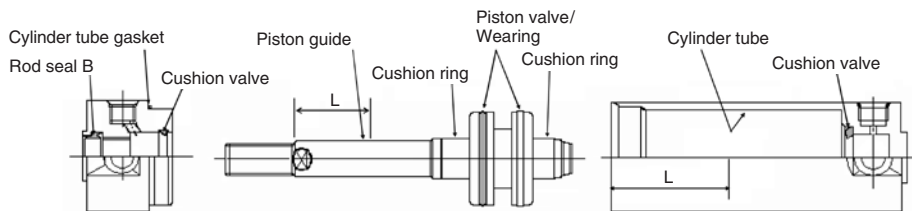

Fig. 9 Grease application points $L = \frac{\text{STROKE}}{2}$ or 100 mm and more

Table. 1 Grease application amount (g)

Stroke	Bore size			
	20	25	32	40
100 st	2	3	3	3 to 4
Extra 50 st	0.5	0.5	0.5	1

6. Reassembly of the Cylinder

- 6-1. Make sure no particles are present. Do not scratch the seals.
- 6-2. Tighten the cover approximately 0-2 degrees more from the original position (where the ports of rod and head covers match).
- 6-3. After completing the assembly, manually check whether the movement is smooth.

7. Replacement Parts

- 7-1. For Series CLG1, lock-up unit (except the long-stroke lock-up) and seals (rod seal B, piston seal, cylinder tube gasket) are replaceable.
- 7-2. Contact SMC sales if it is necessary to replace parts other than those mentioned above.

Series CLG1 Replacement Procedure of Seal 3

8. Replacement Procedure of the Lock Unit

Caution

Series CLG1 lock units are replaceable.
(However, please note that lock units cannot be replaced in the case of long stroke specifications.)

- 8-1. Release the manual lock.
- Loose locking nut.
 - Supply air pressure of 0.3 MPa or more to the lock release port.
 - Turn the wrench flats section of the manual unlocking cam until it stop at the FREE position that is marked on the cam guide.
 - While keeping the wrench flats section in place, tighten the lock nut.

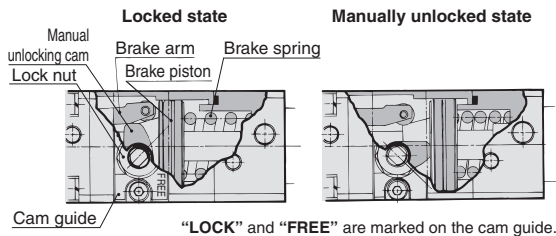

- 8-2. Remove the lock unit by securing the square section of the rod cover or the wrench flats of the tube cover in an apparatus such as a vice, and then loosening the other end with a spanner or adjustable angle wrench, etc.
See the table below for the dimensions of the square section and the wrench flats.

Bore size (mm)	Rod cover square section (mm)	Tube cover wrench flats (mm)
20	38	24
25	45	29
32	45	35.5
40	52	44

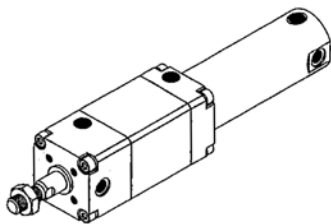

- 8-3. Remove the tube cover.

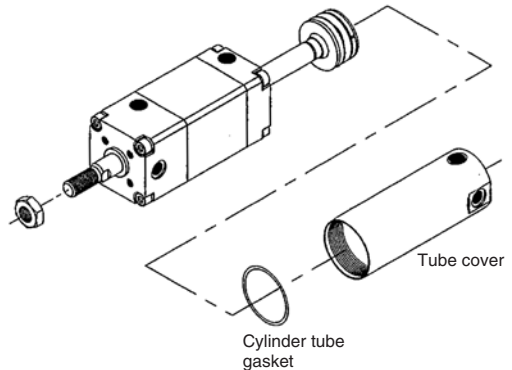

- 8-4. Pull out the piston rod assembly.

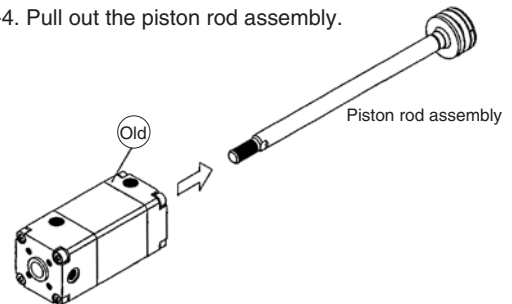

- 8-5. Replace the temporary axis of a new lock unit with the piston rod assembly.

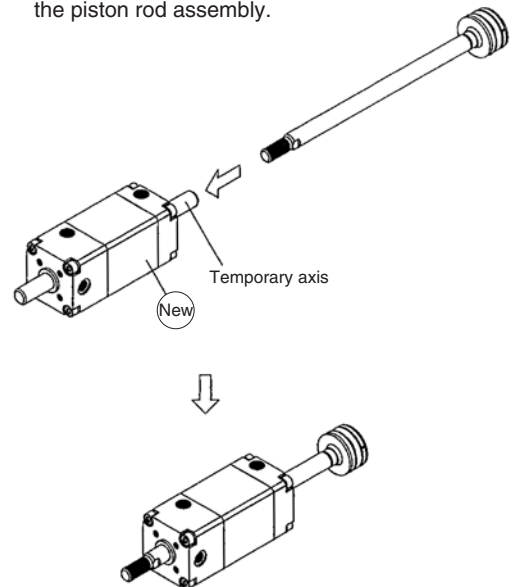

Note) When replacing piston rod assembly with a new lock unit, care should be taken not to cut rod packing B with threads or wrench flats.
Lock the manual unlocking cam before use.

- 8-6. Reassemble by reversing the procedure in steps 8-1. and 8-3. When retightening the sections, turn approximately 2° past their position prior to disassembly.

1. Disassembly of the Cylinder

The cylinder needs to be disassembled and assembled in a clean place.

1-1. Loosen the tie-rod nuts and pull out the four tie-rods.

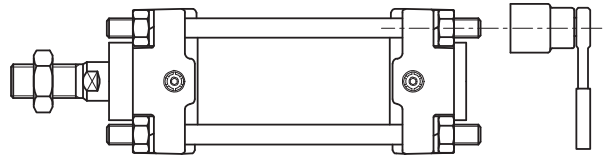
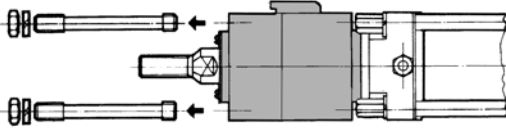

1-2. Open the rubber cap and screw in the unlocking bolt, which is provided as an accessory part. At this time, apply air pressure of 0.2 MPa to 0.3 MPa to disengage the lock and insert the bolt. (The operation to follow can be performed properly and easily with the application of air pressure.) After verifying that the bolt has been inserted properly, pull out the unit from the rod.

Table 1 Work tools

Bore size (mm)	Applicable socket
40, 50	13 (M8)
63	17 (M10)
80, 100	19 (M12)

2. Removal of the seal

2-1. Rod seal

Insert a watchmakers screw driver to pull out the seal.

Take care not to damage the seal groove of the cover. (Fig. 1)

2-2. Piston seal

Remove it as in Fig. 2.

2-3. Tube gasket

Remove it in the same way as Fig. 2.

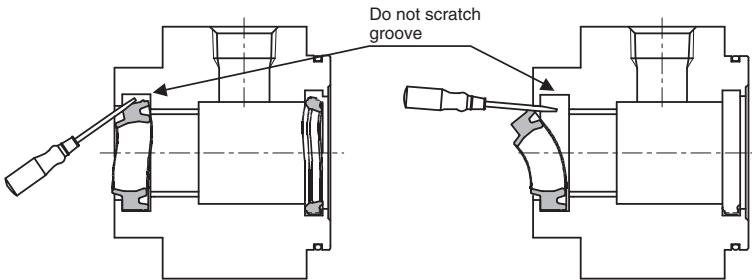

Fig. 1 Removal of rod seal

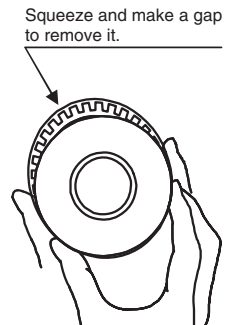

Fig. 2 Removal of piston seal

3. Application of Grease to Seal

3-1. Apply grease slightly to the outer circumference of each seal.

3-2. Fill in the groove of the rod seal with grease.

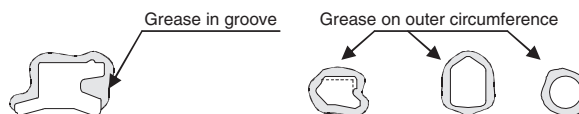

Fig. 3 Grease to the seals

4. Mounting of Seal

4-1. Rod seal

Mount the seal in the correct direction by bending the seal with fingers as Fig. 4.

4-2. Piston seal

Mount the seal while stretching it as in Fig. 5.

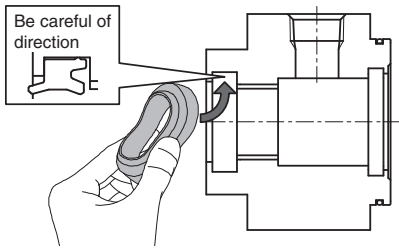

Fig. 4 Installation of rod seal

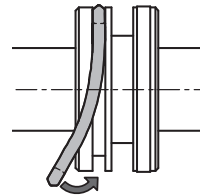

Fig. 5 Installation of piston seal

5. Application of Grease

5-1. Rod seal

Apply grease to the seal and the inner circumference of the bush. (Fig. 6)

5-2. Piston seal

Rub grease into the seal groove and outer circumference of the seal. (Fig. 7)

5-3. Cylinder component parts

Apply grease to each component parts of the cylinder in Figure 9. Appendix table shows the grease amount required for a cylinder with stroke 100. For your reference, amount taken with a forefinger is about 3 g. (Fig. 8)

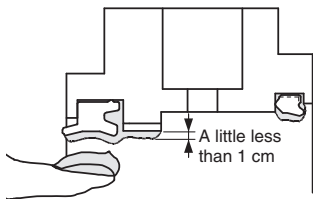

Fig. 6 Rod seal
Cushion seal

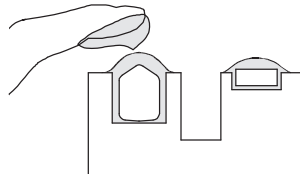

Fig. 7 Piston seal

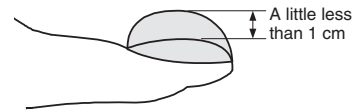

Fig. 8 Grease amount

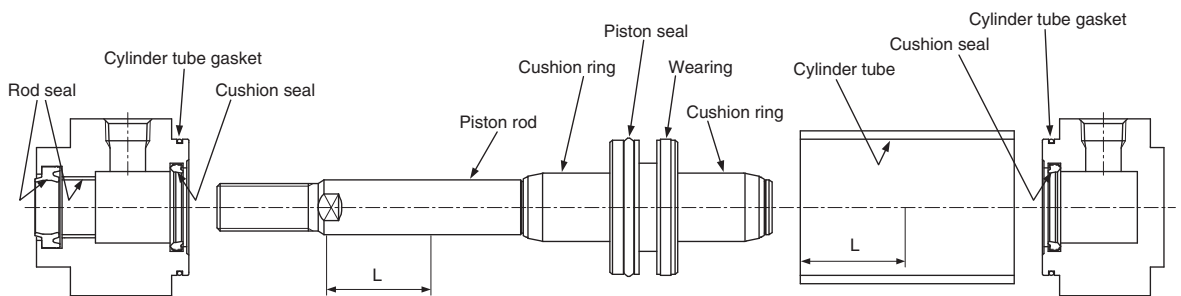

Fig. 9 Grease application points

$$L = \frac{\text{STROKE}}{2} \text{ or } 100 \text{ mm and more}$$

Table 2 Grease application amount (g)

Stroke	Bore size						
	32	40	50	63	80	100	125
100 st	3 to 4	3 to 4	3 to 5	4 to 5	6 to 8	8 to 10	15 to 17
Extra 50 st	1	1	1	1.5	1.5	2	3

6. Reassembly of the Cylinder

- 6-1. Make sure no particles are present. Do not scratch the seals.
- 6-2. To assemble the tie rod to the cylinder, tighten the tie rod to the shorter screw side by hand.
- 6-3. Set the tie rod nuts from the head cover side. Tighten the tie rod nut so that the tensile force is even.
Refer to the appropriate tightening torque of table 3.
Brackets refer to the same table.

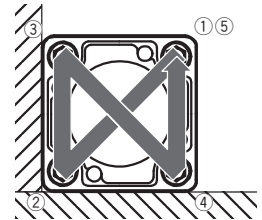

Fig. 10 Tie rod tightening order.

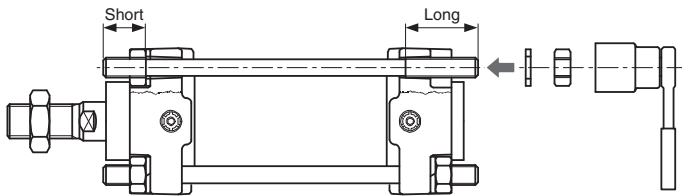
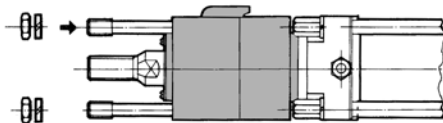

Table 3 Appropriate tightening torque

Bore size (mm)	Appropriate tightening torque (N·m)
40, 50	10.8
63	24.5
80, 100	38.2

- 6-4. Install four tie-rods, with their shorter threaded portion oriented towards the rod cover, and tighten them with uniform torque. Until the installation and adjustment have been completed, never pull out the unlocking bolt (or release the air pressure).



Series CL1 $\varnothing 125$ to $\varnothing 160$ Replacement Procedure of Seal 4

1. Disassembly

- 1-1. Disassembly should be done in a wide space containing little dust.
- 1-2. After removing the cylinder, be sure to protect the end of piping port and rubber hose on the machine side with clean waste to prevent dust from entering.
- 1-3. Disassemble the unit with care to prevent damage to the sliding portion.
- 1-4. Check the double chamfered portion at the rod end for burrs to prevent damage to the seal and the bushing when removing the lock-up unit from the piston rod. If burrs are found, remove them with a "file".
- 1-5. Loosen the tie-rod nuts and pull out the four tie-rods.

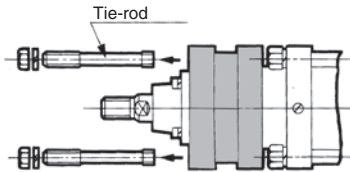

- 1-6. Apply air pressure of 0.2 MPa to 0.3 MPa to disengage the lock and pull out the lock-up unit from the piston rod.

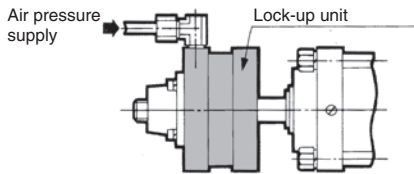

- 1-7. Loosen either of nuts for head side tie rod with "ratchet handle for socket wrench", "T-type slide handle for socket wrench" or "spinner handle for socket wrench", etc. and remove it from the tie rod. Please refer to the table for "socket for socket wrench".

Bore size (mm)	Nut	Applicable socket
125, 140	Class1, M14 x 1.5	JISB4636 Dodecagon22
160	Class1, M16 x 1.5	JISB4636 Dodecagon24

- 1-8. Remove 4 tie rods from cover.
- 1-9. Remove the push plate (rod cover) from the piston rod with care to prevent damage to the seal and bushing.
- 1-10. Pull the piston rod and pull out the piston from the cylinder tube.
- 1-11. Remove the cylinder tube from the head cover.

- 1-12. Disassembly of the rod cover (For the head cover, it should also be in accordance with this procedure.)
 - a. Remove the cylinder tube gasket. When excessive deformation or cut is found with the gasket, replace it.
 - b. Remove the cushion valve from the cover by using "flat blade screwdriver".
(Tool; Screwdriver Nominal size 8 x 150 Normal type, Normal class)
 - c. Remove the cushion valve seal from the cushion valve by using "waste".
 - d. Loosen the hexagon socket head cap screw for push plate by using "hexagon wrench" and remove the push plate. Applicable "Hexagon wrenches" are shown in the table below.

Bore size (mm)	Hexagon socket head cap screw	Nominal size of wrench
125, 140, 160	M8 x 1.25 x 25L	6

- e. Remove the wiper ring. If it cannot be removed by hand, use a small "flat blade screwdriver" and remove it with care to prevent damage to it.
- f. Remove the rod seal by using a small "flat blade screwdriver" with care to prevent damage to it.
- g. Remove the push plate gasket.
- h. Since the cushion seal is pressed fit, air will leak from the portion where the cushion seal is pressed fit due to damage or change in pressing force. Therefore when the cushion seal should be replaced, the rod cover assembly and the head cover assembly should be replaced. (Rod and head covers are not replaceable for type 2 pressure containers. Please consult with SMC for more detail.)
- i. Since the bushing is pressed fit into push plate, it is difficult to remove structurally and even if it is removed, stock for press fit lowers when it is pressed fit again. Therefore when it is replaced, replace the push plate assembly.

2. Replacement Procedure of Seal

2-1. Removal of the seal

Please refer to "1. Disassembly" for dismantling of wiper ring, rod seal, valve seal, tube gasket and push plate gasket.

Since piston seal has a deep groove for sealing, use your hand (not a watchmakers screw driver) and push from one side of seal and pull it out when it lifts off.

2-2. Application of grease

a. Seals: Apply thin coat of grease.

b. Cylinder component

Apply grease to the individual components as the figure below. The table shows the grease amount required for a cylinder with stroke 100.

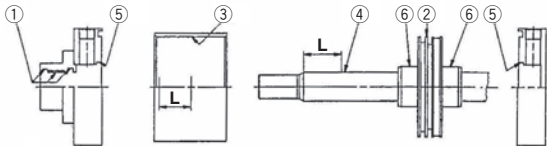

Grease application amount (g)

bore size (mm)	125	140	160	Portion to apply
100 st	15 to 17	20 to 22	24 to 26	① to ⑥
50 st up	3	3	3	③④

For grease, use lithium soap group grease JIS #2

2-3. Mounting of seal

a. Wiper ring/Rod seal

Mount in correct direction.

b. Seals other than wiper ring

After mounting seals, apply grease on inside diameter surfaces of bushing (rubbing grease into surface).

3. Assembly

3-1. Before assembling cylinder, be sure to clean each part to remove dust.

3-2. Before assembling, apply rod, bushing, tube and seal with enough grease.

3-3. For rusty part, remove the rust completely.

3-4. Assembly should be done in a clean place with care to prevent foreign matters from entering.

3-5. Mount seal with care to prevent damage to it.

3-6. Insert piston into tube or rod into bushing with care to prevent damage to each seal.

3-7. Tighten tie rod and bolt with appropriate torque shown in the table below.

Tightening torque (N·m)

Bore size (mm)		125	140	160
Tie rod	Steel tube	49		75.5
	Aluminum tube		39.2	62.8
Push plate bolt		11		

3-8. Insert the lock-up unit to the piston rod while the lock is released with the air pressure of 0.2 to 0.3 Mpa, Install the four tie-rods, with their shorter threaded portion oriented towards the rod cover, and tighten them with uniform torque.

Maintain the application of air pressure until the installation and adjustment have been completed, and never actuate the lock in the meantime.

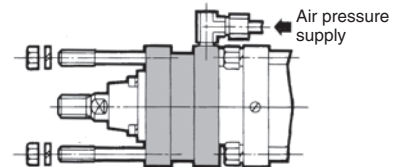

Series CNG Replacement Procedure of Seal 1

1. Disassembly of the Cylinder

1-1. The cylinder needs to be disassembled and assembled in a clean place.

1-2. Refer to the "Replacement Procedure of the Lock Unit" (CNG-3) ① to ③ for disassembly.

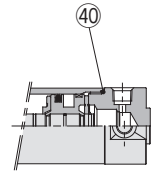
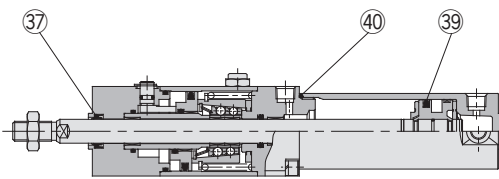

Long stroke

- ③7 Rod seal A
- ③9 Piston seal
- ④0 Cylinder tube gasket

2. Removal of the Seal

③7 Rod seal A: Insert a watchmakers screw driver to pull out the seal.

Take care not to damage the seal groove of the cover. (Fig. 1)

③8 Piston seal: Remove the piston seal. (Fig. 2)

④0 Cylinder tube gasket: Insert a watchmakers screw driver to pull out the seal.

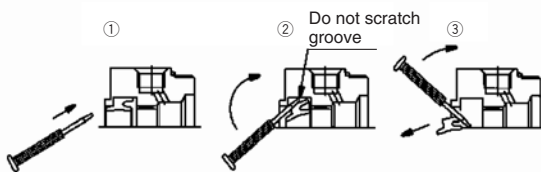

Fig. 1 Removal of rod seal

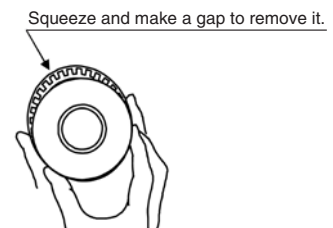

Fig. 2 Removal of piston seal

3. Application of Grease to Seal

3-1. Apply grease slightly to the outer circumference of each seal.

3-2. Fill in the groove of the rod seal with grease.

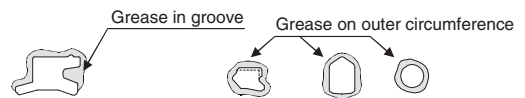

Fig. 3 Grease to the seals

4. Mounting of Seal

③7 Rod seal A: Mount the seal in the correct direction.

③9 Piston seal: Mount the seal while stretching it as Fig. 5.

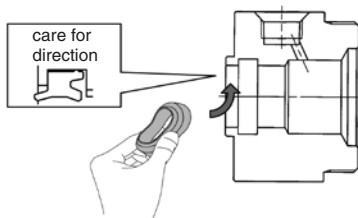

Fig. 4 Installation of rod seal

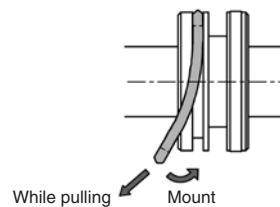

Fig. 5 Installation of piston seal

5. Application of Grease

- ③⑦ Rod seal A: Apply grease to the seal and the inner circumference of the bush. (Fig. 6)
Use a precision screwdriver to apply grease to the small bore diameter while making sure not to leave scratches.
- ③⑨ Piston seal: Rub grease into the seal groove and outer circumference of the seal. (Fig. 7)
- ③⑩ Cylinder tube gasket: Lightly apply grease.
- Cylinder component parts: Apply grease to each component parts of the cylinder in Figure 9.
Appendix table shows the grease amount required for a cylinder with stroke 100.
For your reference, amount taken with a forefinger is about 3 g. (Fig. 8)

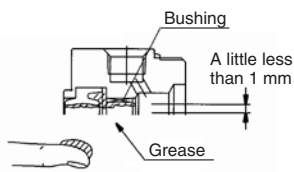

Fig. 6 Rod seal

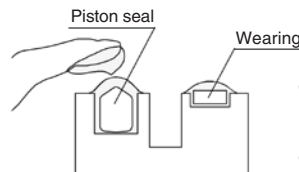

Fig. 7 Piston seal

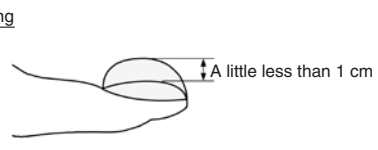

Fig. 8 Grease amount

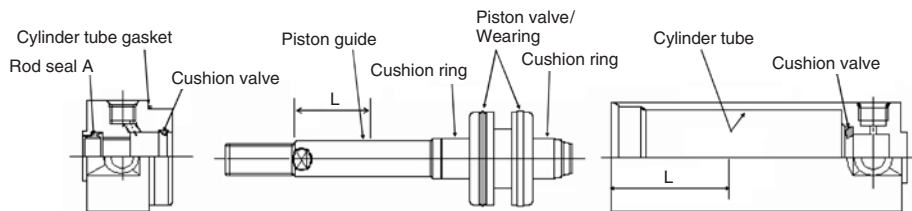

Fig. 9 Grease application points $L = \frac{\text{STROKE}}{2}$ or 100 mm and more

Grease application amount (g)

Stroke	Bore size			
	20	25	32	40
100 st	2	3	3	3 to 4
Extra 50 st	0.5	0.5	0.5	1

6. Reassembly of the Cylinder

- 6-1. Make sure no particles are present. Do not scratch the seals.
- 6-2. Tighten the cover approximately 0-2 degrees more from the original position (where the ports of rod and head covers match).
- 6-3. After completing the assembly, manually check whether the movement is smooth.

7. Replacement Parts

- 7-1. For Series CNG, lock-up unit (except the long-stroke) and seal (rod seal B, piston seal, cylinder tube gasket) are replaceable.
- 7-2. Contact SMC sales if it is necessary to replace parts other than those mentioned above.

8. Replacement Procedure of the Lock Unit

⚠ Caution

Series CNG lock units are replaceable.

(However, please note that lock units cannot be replaced in the case of long stroke specifications.)

8-1. Remove the lock unit by securing the square section of the rod cover or the wrench flats of the tube cover in an apparatus such as a vice, and then loosening the other end with a spanner or adjustable angle wrench, etc.

See the table below for the dimensions of the square section and the wrench flats.

Bore size (mm)	Rod cover square section (mm)	Tube cover wrench flats (mm)
20	38	24
25	45	29
32	45	35.5
40	52	44

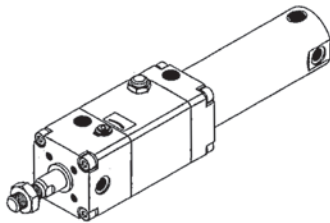

8-2. Remove the tube cover.

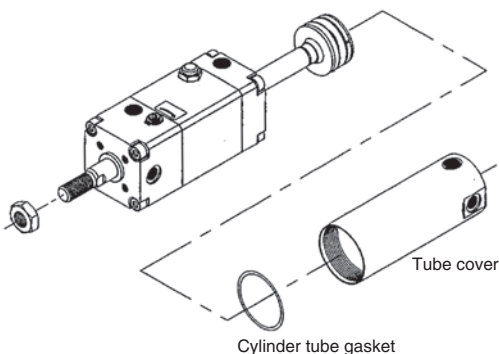

8-3. Apply compressed air of 0.3 MPa or more to the unlocking port, and pull out the piston rod assembly.

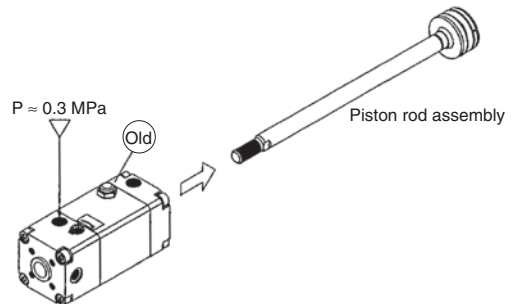

8-4. Similarly apply compressed air of 0.3 MPa or more to the unlocking port of the new lock unit, and replace the temporary axis with the previous piston rod assembly.

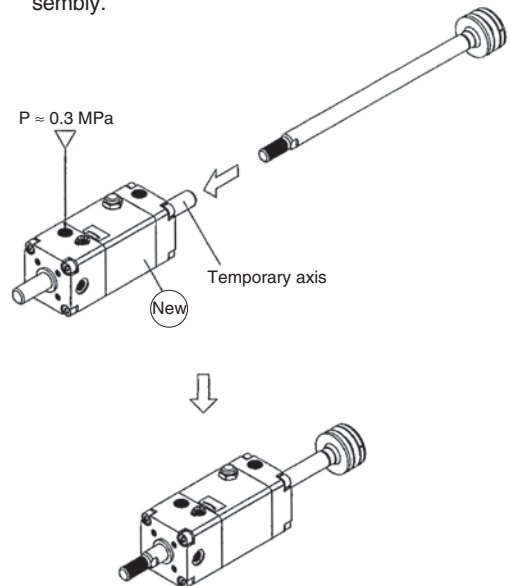

Note) When replacing piston rod assembly with a new lock unit, care should be taken not to cut rod packing B with threads or wrench flats.

Be sure to keep applying compressed air with a pressure of at least 0.3 MPa to the lock releasing port when replacing the temporary axis of a new lock unit with a piston rod assembly.

If the compressed air applied to the lock releasing port is released (when it is in the lock condition) while the temporary rod and the piston rod assembly are removed from the lock unit, the brake shoe will be deformed and it will become impossible to insert the piston rod assembly, which will make the lock unit impossible to use.

8-5. Reassemble by reversing the procedure in steps 8-1. and 8-2. When retightening the sections, turn approximately 2° past their position prior to disassembly.

1. Disassembly of the Cylinder

The cylinder needs to be disassembled and assembled in a clean place.

Series MNB

How to Replace Lock Units ② (Page 354)
Refer to a to c.

Table 1 Work tools

Bore size (mm)	Width across flats of a hexagon wrench	
	When removing the support bracket	When removing the tie-rod nut
32, 40	4	6
50, 63	5	8
80, 100	6	10
125	8	12

Series CNA2

How to Replace Lock Units ② (Page 355)
Refer to a to c.

Table 2 Work tools

Bore size (mm)	Applicable socket
40, 50	13 (M8)
63	17 (M10)
80, 100	19 (M12)

2. Removal of the Seal

2-1. Rod seal, cushion seal

Insert a watchmakers screw driver to pull out the seal.

Take care not to damage the seal groove of the cover. (Fig. 1)

2-2. Piston seal

Remove it as in Fig. 2.

2-3. Tube gasket

Remove it in the same way as Fig. 2.

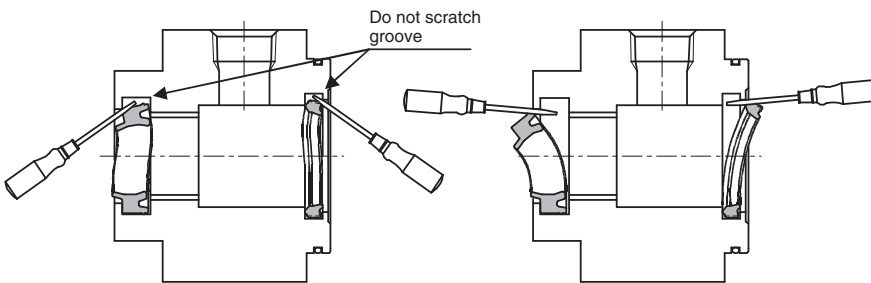

Fig. 1 Removal of rod seal, cushion seal

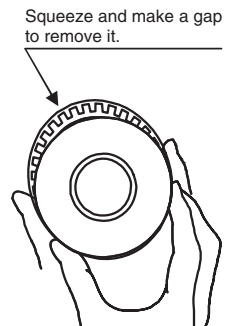

Fig. 2 Removal of piston seal

3. Application of Grease to Seal

3-1. Apply grease slightly to the outer circumference of each seal.

3-2. Fill in the groove of the rod seal with grease.

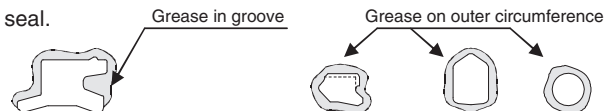

Fig. 3 Grease to the seal

4. Mounting of Seal

4-1. Rod seal, cushion seal

Mount the seal in the correct direction by bending the seal with fingers as Fig. 4.

4-2. Piston seal

Mount the seal while stretching it as in Fig. 5.

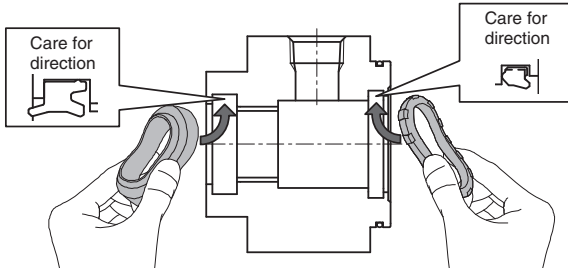

Fig. 4 Installation of rod seal, cushion seal

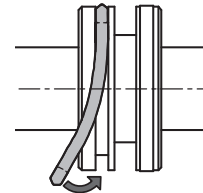

Fig. 5 Installation of piston seal

5. Application of Grease

5-1. Rod seal, cushion seal

Apply grease to the seal and the inner circumference of the bush. (Fig. 6)

5-2. Piston seal

Rub grease into the seal groove and outer circumference of the seal. (Fig. 7)

5-3. Cylinder component parts

Apply grease to each component parts of the cylinder in Figure 9. Appendix table shows the grease amount required for a cylinder with stroke 100. For your reference, amount taken with a forefinger is about 3 g. (Fig. 8)

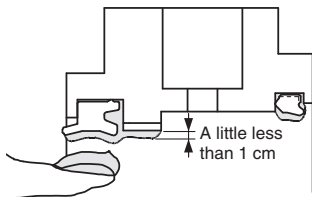

Fig. 6 Rod seal
Cushion seal

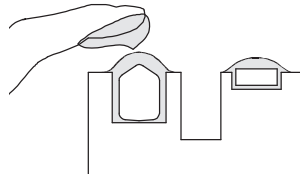

Fig. 7 Piston seal

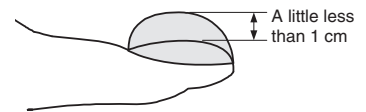

Fig. 8 Grease amount

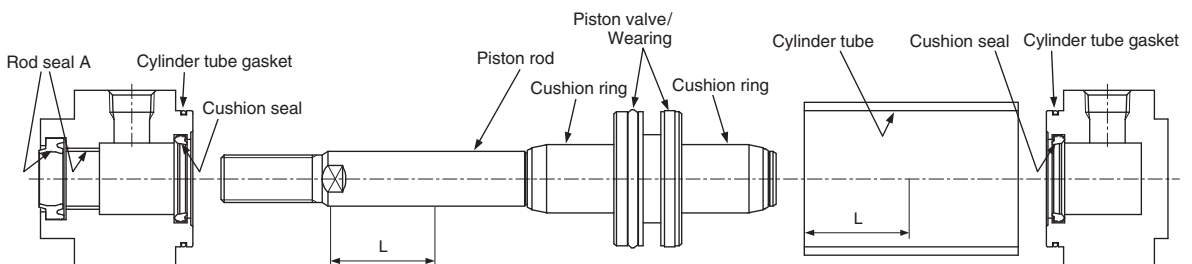

Fig. 9 Grease application points

$$L = \frac{\text{Stroke}}{2} \text{ or } 100 \text{ mm and more}$$

Grease application amount (g)

Stroke	Bore size						
	32	40	50	63	80	100	125
100 st	3 to 4	3 to 4	3 to 5	4 to 5	6 to 8	8 to 10	15 to 17
Extra 50 st	1	1	1	1.5	1.5	2	3

6. Reassembly of the Cylinder

- 6-1. Make sure no particles are present. Do not scratch the seals.
- 6-2. Assemble the cylinder following the Replacement Procedure of Lock-up Unit 2, c through a.
 - MNB (Page 354)
 - CNA2 (Page 355)
- 6-3. To assemble the tie rod to the cylinder, tighten the tie rod to the shorter screw side by hand from the head cover side.
- 6-4. Set the tie rod nuts. Tighten the tie rod nut so that the tensile force is even. Refer to the appropriate tightening torque of table 4 and 5. Brackets refer to the same table.

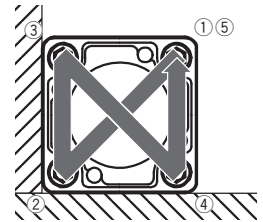

Fig. 10 Tie rod tightening order

Series *MNB*

Table 4 Appropriate tightening torque

Bore size (mm)	Appropriate tightening torque (N·m)
32, 40	5.1
50, 63	11.0
80, 100	25.0
125	30.0

Series *CNA2*

Table 5 Appropriate tightening torque

Bore size (mm)	Appropriate tightening torque (N·m)
40, 50	10.8
63	24.5
80, 100	38.2

7. Replacement Procedure of the Lock Unit

Series MNB

Warning

Although the MNB series lock unit is replaceable, Do not disassemble the lock unit.

1. Series MNB lock units are replaceable.
2. How to replace the lock unit
 - a. Loosen the cylinder head cover tie rod nuts (four) with a hexagon wrench. Refer to the table below for applicable.

Bore size (mm)	Width across flats of a hexagon wrench
32, 40	6
50, 63	8
80, 100	10

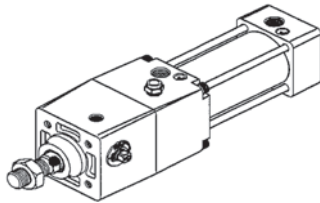

- b. Remove the tie rods, head cover and cylinder tube

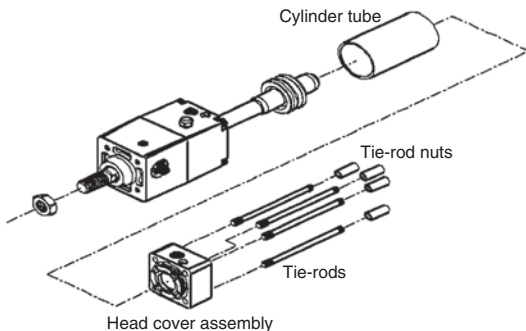

- c. Apply 0.3 MPa or more of pressure to the lock release port to pull out the piston rod assembly.

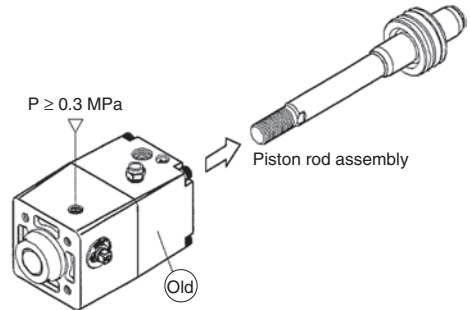

- d. Apply 0.3 MPa or more of pressure to new lock unit lock release port to change the piston rod assembly to the tentative rod.

Note1) Attention should be taken not to cut rod packing B with screws and the spanner flat when replacing the piston rod Assembly to new lock unit.

Note2) Be sure to keep applying compressed air with a pressure of at least 0.3 MPa to the lock releasing port when replacing the temporary axis of a new lock unit with a piston rod assembly.

If the compressed air applied to the lock releasing port is released (when it is in the lock condition) while the temporary rod and the piston rod assembly are removed from the lock unit, the brake shoe will be deformed and it will become impossible to insert the piston rod assembly, which will make the lock unit impossible to use.

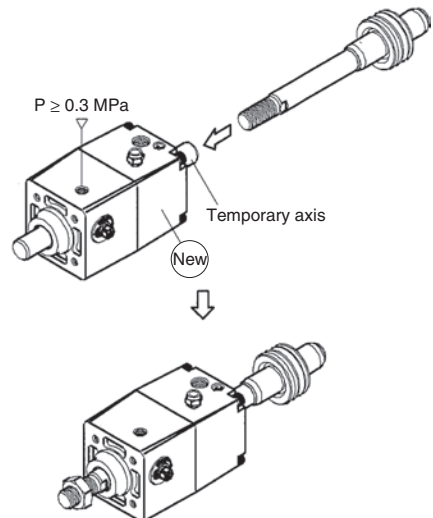

- e. Reassemble in reverse order from b to a

Caution

Don't apply grease nor oil to the piston rod surface.

Series MNB/CNA2 Replacement Procedure of Seal 5

Series CNA2

1. CNA2 series lock unit is replaceable.
2. How to replace the lock unit
 - a. Loosen the tie-rod nuts (4 pieces) on the cylinder head cover side by using a socket wrench.
For applicable socket, refer to the below table.

Bore size (mm)	Nut mounting bracket		
	Nut	Width across flats dimension	Socket
40, 50	JISB1181 Class2 M8 x 1.25	13	JISB4636 + 2-point angle socket 13
63	JISB1181 Class2 M10 x 1.25	17	JISB4636 + 2-point angle socket 17
80, 100	JISB1181 Class2 M12 x 1.75	19	JISB4636 + 2-point angle socket 19

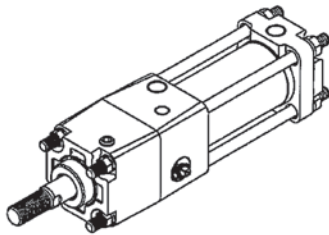

- b. Remove the tie rods, head cover and cylinder tube.

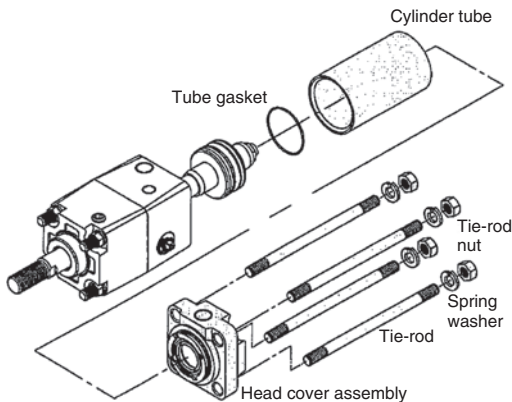

- c. Apply 0.3 MPa or more of compressed air to the unlocking port, and pull out the piston rod assembly.

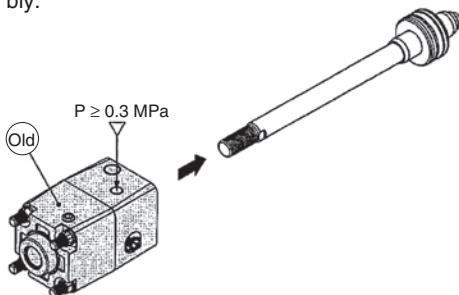

- d. Similarly, apply 0.3 MPa or more of compressed air to the unlocking port of the new lock unit, and replace the new lock unit's temporary axis with the previous piston rod assembly.

Note1) Attention should be taken not to cut rod seal B with screws and the spanner flat when replacing the piston rod assembly to new lock unit.

Note2) Be sure to keep applying compressed air with a pressure of at least 0.3MPa to the lock releasing port when replacing the temporary axis of a new lock unit with a piston rod assembly.

If the compressed air applied to the lock releasing port is released (when it is in the lock condition) while the temporary rod and the piston rod assembly are removed from the lock unit, the brake shoe will be deformed and it will become impossible to insert the piston rod assembly, which will make the lock unit impossible to use.

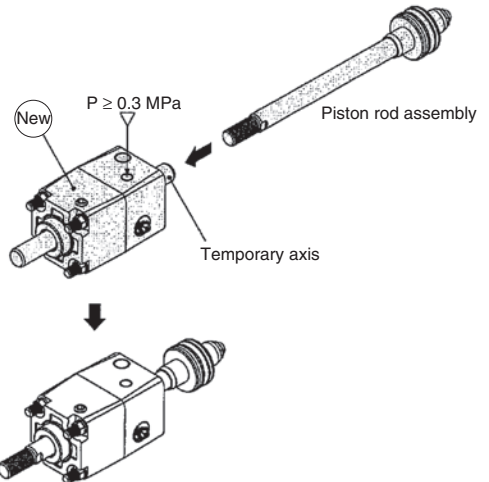

- e. Reassemble in reverse order from step b to a.

⚠ Caution

Don't apply grease nor oil to the piston rod surface.

Series CNS Replacement Procedure of Seal ①

1. Disassembly

- 1-1. Disassembly should be done in a wide space containing little dust.
- 1-2. After removing the cylinder, be sure to protect the end of piping port and rubber hose on the machine side with clean waste to prevent dust from entering.
- 1-3. Disassemble the unit with care to prevent damage to the sliding portion.
- 1-4. Check the double chamfered portion at the rod end for burrs to prevent damage to the seal and the bushing when removing the lock unit from the piston rod. If burrs are found, remove them with a "file".
- 1-5. Remove the lock unit according to section 4, Replacing Procedures of Lock Unit.
- 1-6. Loose either of nuts for head side tie rod with "ratchet handle for socket wrench", "T-type slide handle for socket wrench" or "spinner handle for socket wrench", etc. and remove it from the tie rod. Refer to the table for "socket for socket wrench".

Bore size (mm)	Nut	Applicable socket
125, 140	Class1, M14 x 1.5	JISB4636 Dodecagon22
160	Class1, M16 x 1.5	JISB4636 Dodecagon24

- 1-7. Remove 4 tie rods from cover.
- 1-8. Remove the rod cover from the piston rod with care to prevent damage to the seal and bushing.
- 1-9. Pull the piston rod and pull out the piston from the cylinder tube.
- 1-10. Remove the cylinder tube from the head cover.
Remove the wiper ring of the lock unit. If it cannot be removed by hand, use a small "flat blade screwdriver" and remove it with care to prevent damage to it.
- 1-11. Disassembly of the rod cover (For the head cover, it should also be in accordance with this procedure.)
 - a. Remove the cylinder tube gasket. When excessive deformation or cut is found with the gasket, replace it.
 - b. Remove the cushion valve from the cover by using "flat blade screwdriver".
(Tool; Screwdriver nominal size 8x150 Normal type, Normal class)
 - c. Remove the cushion valve seal from the cushion valve by using "waste".
 - d. Loosen the hexagon socket head cap screw for push plate B by using "hexagon wrench" and remove the push plate D. Applicable "Hexagon wrenches" are shown in the table below.
 - e. Remove the rod seal by using a small "flat blade screwdriver" with care to prevent damage to it.
 - f. Remove the push plate gasket.

Bore size (mm)	Hexagon socket head cap screw	Nominal size of wrench
125, 140, 160	M8 x 1.25 x 25L	6

- g. Since the cushion seal is pressed fit, air will leak from the portion where the cushion seal is pressed fit due to damage or change in pressing force. Therefore when the cushion seal should be replaced, the rod cover assembly and the head cover assembly should be replaced.

2. Replacement Procedure of Seal

2-1. Removal of the seal

Please refer to "1. Disassembly" for dismantling of wiper ring, rod seal, valve seal, tube gasket and push plate gasket.

Since piston seal has a deep groove for sealing, use your hand (not a watchmakers screw driver) and push from one side of seal and pull it out when it lifts off.

2-2. Application of grease

- a. Seals: Apply thin coat of grease.
- b. Cylinder component

Apply grease to the individual components as the figure below. The table shows the grease amount required for a cylinder with stroke 100.

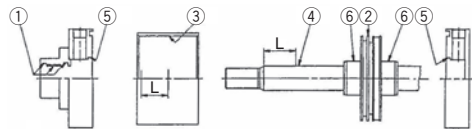

Grease application amount (g)

Bore size (mm)	125	140	160	Portion to apply
100 st	15 to 17	20 to 22	24 to 26	① to ⑥
50 st extra	3	3	3	③④

For grease, use lithium soap group grease JIS #2.

2-3. Mounting of seal

- a. Wiper ring/Rod seal
Mount in correct direction.
- b. Seals other than wiper ring
After mounting seals, apply grease on inside diameter surfaces of bushing (rubbing grease into surface).

Series CNS Replacement Procedure of Seal ②

3. Assembly

- 3-1. Before assembling cylinder, be sure to clean each part to remove dust.
- 3-2. Before assembling, apply rod, bushing, tube and seal with enough grease.
- 3-3. For rusty part, remove the rust completely.
- 3-4. Assembly should be done in a clean place with care to prevent foreign matters from entering.
- 3-5. Mount seal with care to prevent damage to it.
- 3-6. Insert piston into tube or rod into bushing with care to prevent damage to each seal.
- 3-7. Tighten tie rod and bolt with appropriate torque shown in the table below.

Tightening torque (N·m)

Bore size (mm)		125	140	160
Tie rod	Steel tube	49		75.5
	Aluminum tube	39.2		62.8
Push plate bolt		11		

4. Replacement Procedure of the Lock Unit

- 4-1. Lock unit for Series CNS can be replaced.
- 4-2. Replacing procedures of lock unit
 - a. Loosen tie-rod nut (4 pieces) on rod cover side of cylinder with socket wrench.

Bore size (mm)	Nut	Dimension of width across flats	Socket
125, 140	JIS B1181 M14 x 1.5	22	JIS B4636 Socket22
160	JIS B1181 M16 x 1.5	24	JIS B4636 Socket24

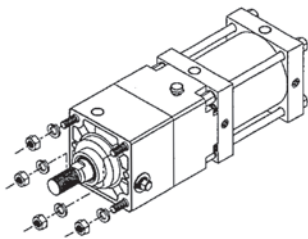

- b. Remove lock unit by applying compressed air over 0.3 MPa to lock release port.

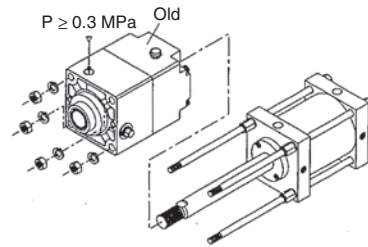

- c. Also apply compressed air over 0.3 MPa to new lock unit and replace piston rod of cylinder with temporary shaft.

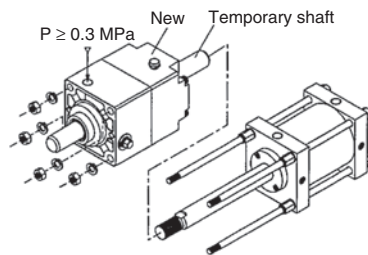

Note) To replace the piston rod assembly with the temporary shaft of a new lock unit, make sure that the compressed air of 0.3 MPa or higher is kept applied to the lock release port.

If the compressed air is exhausted (locked state) while the temporary shaft and piston rod assembly are pulled out from the lock unit, a brake shoe will be deformed and the piston rod assembly cannot be inserted. This makes the lock unit unusable.

- d. Tighten tie-rod nut (4 pieces) on cylinder rod side with socket wrench.

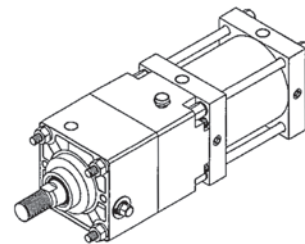

⚠ Warning

Customer shall not disassemble the CNS series lock unit.

1. Because of powerful spring installed, do not loosen or remove hexagon socket head cap screws fixing covers A and B (parts may be shot out).
2. Please consult with our sales person if disassembly and repair are necessary.

⚠ Caution

Apply grease and oil to the surface of piston rod only when it is necessary.

Series **CLS** Replacement Procedure of Seal 1

1. Disassembly

- 1-1. Disassembly should be done in a wide space containing little dust.
- 1-2. After removing the cylinder, be sure to protect the end of piping port and rubber hose on the machine side with clean waste to prevent dust from entering.
- 1-3. Disassemble the unit with care to prevent damage to the sliding portion.
- 1-4. Check the double chamfered portion at the rod end for burrs to prevent damage to the seal and the bushing when removing the lock unit from the piston rod. If burrs are found, remove them with a "file".
Remove the lock unit according to "Appendix. Replacement Procedures of Lock Unit".
- 1-5. Side of the head of nuts for tie rod with "ratchet handle for socket wrench", "T-type slide handle for socket wrench" or "spinner handle for socket wrench", etc. and remove it from the tie rod. Refer to the table for "socket for socket wrench".

Bore size (mm)	Nut	Applicable socket
125-140	Class1, M14 x 1.5	JISB4636 Dodecagon22
160	Class1, M16 x 1.5	JISB4636 Dodecagon24
180	Class1, M18 x 1.5	JISB4636 Dodecagon27
200	Class1, M20 x 1.5	JISB4636 Dodecagon30
250	Class1, M24 x 1.5	JISB4636 Dodecagon36

- 1-6. Remove 4 tie rods from cover.
- 1-7. Remove the rod cover from the piston rod with care to prevent damage to the seal and bushing.
- 1-8. Pull the piston rod and pull out the piston from the cylinder tube.
- 1-9. Remove the cylinder tube from the head cover.
Remove the wiper ring of lock unit. If it cannot be removed by hand, use a small "flat blade screwdriver" and remove it with care to prevent damage to it.
- 1-10. Disassembly of the rod cover (For the head cover, it should also be in accordance with this procedure.)
 - a. Remove the cylinder tube gasket. When excessive deformation or cut is found with the gasket, replace it.
 - b. Remove the cushion cover from the cover by using "flat blade screwdriver".
(Tool; Screwdriver nominal size 8x150 normal type, normal class)
 - c. Remove the cushion valve seal from the cushion valve by using "waste".
 - d. Loosen the hexagon socket head cap screw for push plate by using "hexagon wrench" and remove the push plate. Applicable "Hexagon wrenches" are shown in the table right above.

Bore size (mm)	Hexagon socket head cap screw	Nominal size of wrench
125, 140, 160	M8 x 1.25 x 16L	6
180, 200	M10 x 1.5 x 18L	8
250	M12 x 1.75 x 22L	10

- e. Remove the rod seal by using a small "flat blade screwdriver" with care to prevent damage to it.
- f. Remove the push plate gasket.
- g. Since the cushion seal is pressed fit, air will leak from the portion where the cushion seal is pressed fit due to damage or change in pressing force. Therefore when the cushion seal should be replaced, the rod cover assembly and the head cover assembly should be replaced.

2. Replacement Procedure of Seal

2-1. Removal of the seal

Please refer to "1. Disassembly" for dismantling of wiper ring, rod seal, valve seal, tube gasket and push plate gasket.

Since piston seal has a deep groove for sealing, use your hand (not a screw driver) and push from one side of seal and pull it out when it lifts off.

2-2. Application of grease

- a. Seals: Apply thin coat of grease.
- b. Cylinder component

Apply grease to the individual components as the figure below. The table shows the grease amount required for a cylinder with stroke 100.

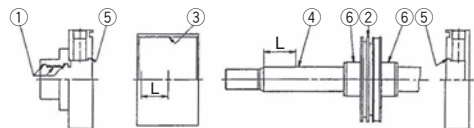

Grease application amount (g)

Bore size (mm)	125	140	160	180	200	250	Portion to apply
100 st	15 to 17	20 to 22	24 to 26	27 to 29	30 to 32	33 to 35	① to ⑥
50 st extra	3	3	3	4	4	5	③④

For grease, use lithium soap group grease JIS #2.

2-3. Mounting of seal

- a. Wiper ring/Rod seal
Mount in correct direction.
- b. Seals other than wiper ring
After mounting seals, apply grease on inside diameter surfaces of bushing (rubbing grease into surface).

Series CLS Replacement Procedure of Seal 2

3. Assembly

- 3-1. Before assembling cylinder, be sure to clean each part to remove dust.
- 3-2. Before assembling, apply rod, bushing, tube and seal with enough grease.
- 3-3. For rusty part, remove the rust completely.
- 3-4. Assembly should be done in a clean place with care to prevent foreign matters from entering.

Tightening torque (N·m)

Bore size (mm)		125	140	160	180	200	250
Tie rod	Steel tube	49	75.5	103	147.1	254	
	Aluminum tube	39.2	62.8	92.7	132.4	—	
Push plate bolt		11		22		38	

- 3-5. Mount seal with care to prevent damage to it.
- 3-6. Insert piston into tube or rod into bushing with care to prevent damage to each seal.
- 3-7. Tighten tie rod and bolt with appropriate torque shown in the table below.

4. Replacement Procedure of the Lock Unit

4-1. Lock unit for the CLS series can be replaced.

⚠ Caution

1. Never disassemble the lock unit.

A heavy duty spring is contained in part of the unit, which presents a serious hazard if disassembly is performed incorrectly.

In addition, the lock unit is adjusted before shipment. If readjustment is not performed correctly after reassembly, a serious danger will be created, as performance will not meet specifications.

2. Cylinder body and the lock unit are heavy materials. Two or more persons are required for the replacement of the unit after cleaning up the working environment.

3. The brake tube assembly and the lock unit can be separated. Do not disassemble any other parts.

4-2. Loosen the four tie-rod nuts on the rod cover side of the cylinder using the socket wrench.

Refer to the table below for the size of the tie-rod nut.

Bore size (mm)	Tie-rod nut	Width across flats dimension	Socket
125, 140	JISB1181 Class 1 M14 x 1.5	22	JISB4636 + 2-point angle socket22
160	JISB1181 Class 1 M14 x 1.5	24	JISB4636 + 2-point angle socket24
180	JISB1181 Class 1 M14 x 1.5	27	JISB4636 + 2-point angle socket27
200	JISB1181 Class 1 M14 x 1.5	30	JISB4636 + 2-point angle socket30
250	JISB1181 Class 1 M14 x 1.5	36	JISB4636 + 2-point angle socket36

- 4-3. Release the lock by hand or apply 0.25 MPa to the unlocking port and pull out the lock unit from the base cylinder.

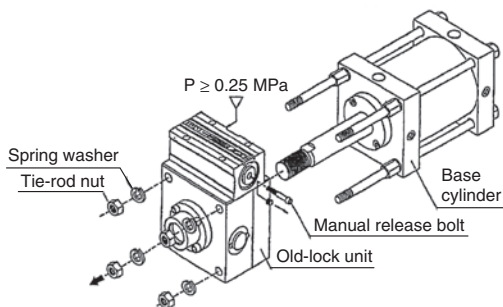

- 4-4. Remove four holding bolts for the new lock unit brake tube assembly and remove the brake tube assembly.

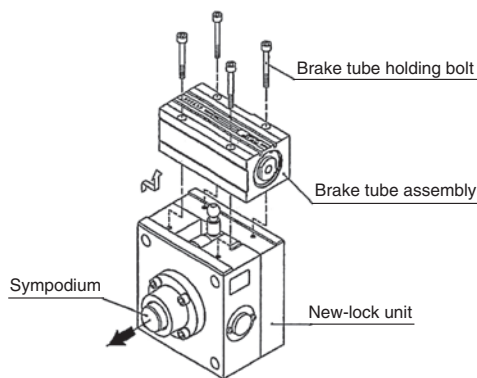

- 4-5. Pull out the temporary shafts from the lock unit and insert the lock unit to the base cylinder.

⚠ Caution

1. Take care not to damage the inner surface of the brake shoe with the width across flats during insertion of the lock unit.

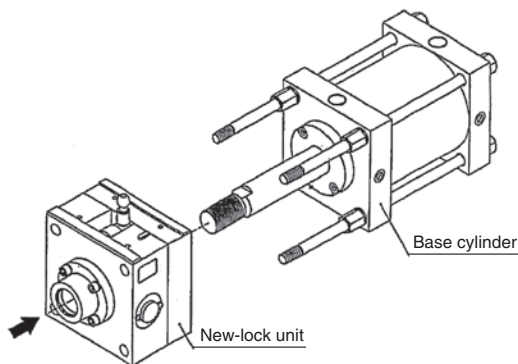

Actuators

Modular F.R.L.
Pressure Control Equipment

Air Preparation
Equipment

Industrial Filters

Replacement
Procedure

Actuators

Modular F.R.L.
Pressure Control Equipment

Industrial Filters

Series *CLS* Replacement Procedure of Seal 3

4-6. After making sure that the key is mounted to the specified location, assemble the brake tube assembly and fix it with holding bolts.

Bore size (mm)	Bolt size	Tightening torque (standard)
125, 140	M6	4.8
160	M8	11.9
180	M8	11.9
200	M10	24.5
250	M12	42

4-7. Lastly, tighten the tie-rod nuts.

Bore size (mm)	Bolt size	Tightening torque (standard)
125, 140	M14	34.3
160	M16	53.9
180	M18	73
200	M20	102
250	M24	180

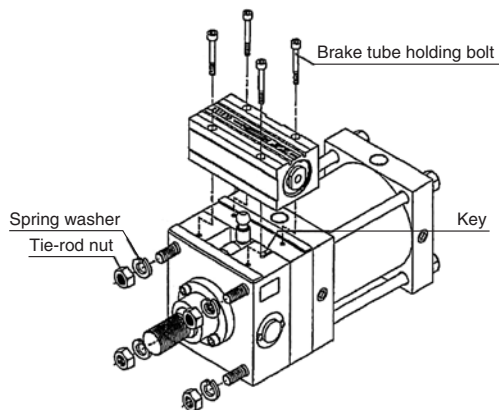

⚠ Caution

Apply 0.08 MPa or more of air pressure to the cylinder port before installing the equipment for checking the operation. Make sure that the manual release bolts are removed before installing the equipment.

Series REAS Replacement Procedure of Seal ①

1. Maintenance

As for sine rodless cylinders, the cushion ring and seal are assembled to provide the optimum cushioning effect.

Therefore, they should be returned to the factory for maintenance.

If you disassemble them by necessity, please note the following points.

- 1-1. To remove external slider or piston slider from cylinder tube, holding force must be released by shifting positions of external slider and slider piston forcibly. Removing those without doing so, respective magnets call each other directly and may become impossible to separate.
- 1-2. Upon completing above works to separate respective sliders, by loosening hexagon head cap screw (at Ipate A side,) remove cylinder tube and plate A from guide rod A and B. (While replacing works (of packing, so on), other parts should not be disassembled, disassembling other parts may cause to air leakage.)
- 1-3. Magnet assembly (piston slider and external slider) must not be disassembled. Disassembling this may cause to decrease of holding force and other defects.
- 1-4. When handle magnet assembly, watch on your arm should be put off not to get influence from strong magnetic field.

1-5. Thorough care should be taken for the magnet not to drop on the floor or knock against metal.

1-6. Make sure the external slider is in the correct direction. (REAS10 only).

Insert the external slider (slide block) and the piston slider to the cylinder tube. If the direction is incorrect (Fig. 2), turn the piston slider 180 degrees then insert. If the direction is not corrected, the specified holding force will not be realized.

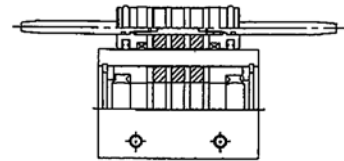

Fig. (1) Correct position

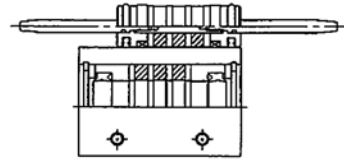

Fig. (2) Incorrect position

Actuators

Modular F.R.L.
Pressure Control Equipment

Air Preparation
Equipment

Industrial Filters

Replacement
Procedure

Actuators

Modular F.R.L.
Pressure Control Equipment

Industrial Filters

Series *REC* Replacement Procedure of Seal ①

1. Disassembly and Reassembly of the Cylinder

A clean place is necessary to disassemble and reassemble the cylinder. Put a clean waste on a working place. For disassembly, hold width across flats of the head cover or rod cover by vice or by spanner or monkey spanner, and loose and remove the covers respectively.

2. Removal of the Seal

2-1. Rod seal

The rod seal A can be replaced with the cylinder mounted. On the other hand, the rod seal B should not be replaced by customer because of its difficulty in mounting works.

Use retaining ring pliers (tool for installing a basic internal retaining ring) to remove the retaining ring, and take the piston rod out from the rod cover with closing the ports of the rod cover by fingers. Then, the seal holder and rod seal A will appear and can be removed from the piston rod.

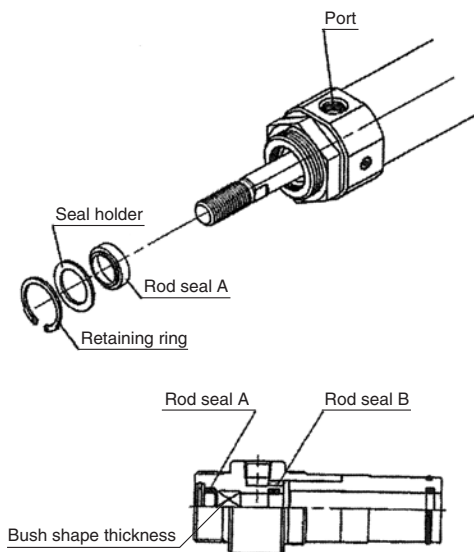

Fig. 1

2-2. Piston seal

Wipe off grease around piston seal first to make removal easier.

Hold piston seal with one hand and push it into groove so that piston seal can be lifted off and pulled out without using a watchmakers screw driver. (Fig. 2)

2-3. Tube gasket

Remove the tube gasket with the watchmakers screw driver or the like. (Be careful not to damage the surrounding parts of the tube gasket.)

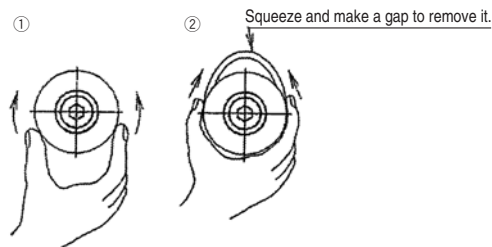

Fig. 2 Removal of piston seal

3. Application of Grease

Use lithium soap base grease equivalent to JIS class 2. You may also order our grease package (GR-S-010 for 10 g and GR-S-020 for 20 g).

3-1. Rod seal

Apply grease thin around the internal and external faces of the new seal for replacement. This is for smooth mounting of the rod seal to the cover and firm fitting between them. Also, the grease is required for the seal groove.

3-2. Piston seal

Apply grease thin and evenly around the internal and external faces of the piston seal for smooth mounting to the piston.

3-3. Tube gasket

Apply grease thin to the tube gasket to prevent it from coming off from the cylinder when assembling.

3-4. Other parts of cylinder

The parts of the cylinder shown in Fig. 3 also require grease to be applied. The amount shall be as specified in Table 1 for one cylinder with 100 stroke. You can consider the amount scooped by index finger to be approx. 3 g. (Fig. 4)

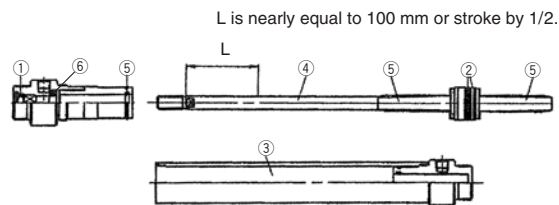

Fig. 3 Grease application points

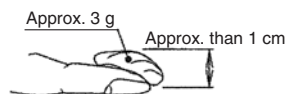

Fig. 4 Grease amount

Table 1 Grease application amount (g)

Stroke	φ20	φ25	φ32	φ40	Applying position
100 st	2	3	3	3 to 4	①②③④⑤⑥
50 st added	0.5	0.5	0.5	1	③④

4. Mounting of Seal

4-1. Rod seal

Mount the rod seal with care for direction. When passing the rod seal through the threaded part at the piston rod end and width across flat, press the rod seal slowly and gradually with rotating. And then, mount it to the housing of the rod cover firmly.

After that, mount the seal holder and retaining ring.

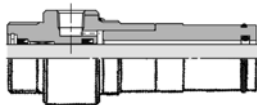

Fig. 5

4-2. Piston seal

Mount the piston seal and rub grease into the inside and the external face of the seal groove as shown in Fig. 6.

4-3. Tube gasket

Mount the tube gasket, apply grease slightly and mount to the head and rod covers.

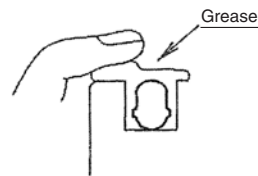

Fig. 6

That is all for the replacement of seals. After they are assembled, check if the cylinder operates smoothly by hand and there is no air leakage as the last step.

Series RHC Replacement Procedure of Seal ①

1. Replacement Procedure of Seal

Seal for cylinder should be disassembled and reassembled on the clean bench without metal chips and dust. Attached metal chips and dust will cause air leakage. Pay great attention to the operation to prevent air leakage.

1-1. Removal of mounting nut and bracket

Bracket such as foot and flange are fixed with nut. Loosen nut to remove bracket and mounting nut.

1-2. Removal of relief valve body holder

Since relief valve body holder is fixed with set screw, use hexagon wrench to loosen it. Relief valve body holder on cover side is slightly deformed due to screw. When relief valve body holder is removed from cover, remove it as rotating.



Picture 1: R/C side



Picture 2: H/C side

1-3. Removal of rod cover

When cylinder cover is removed after relief valve body holders on both rod and head cover side removed, fix head cover with vice and loosen screwed-in rod cover with spanner or monkey wrench.



Picture 3: Fixed (H/C side)



Picture 4: R/C side

1-4. Removal of piston rod assembly

Extract piston rod assembly from tube as rotating it after rod cover is removed,

1-5. Removal of head cover

Loosen screwed-in tube as rotating it with pipe wrench leaving head cover fixed with vice. Pay great attention to the operation to prevent inside of tube from deformation.



Picture 5: H/C side

1-6. Removal of rod seal

Since rod seal is mounted on the cover part where groove is machined, remove it with watchmakers screw driver.

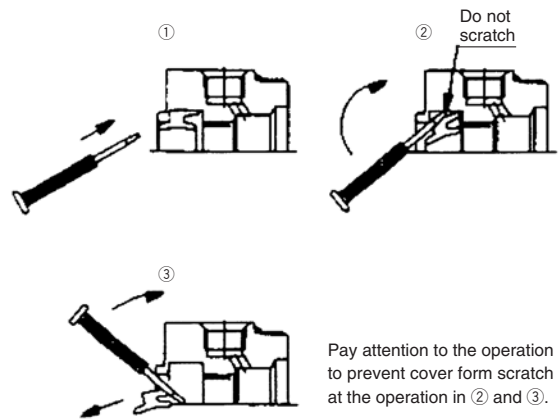

1-7. Removal of piston seal

Wipe off grease around piston seal to remove it easily, then remove it in accordance with the procedure stated below.

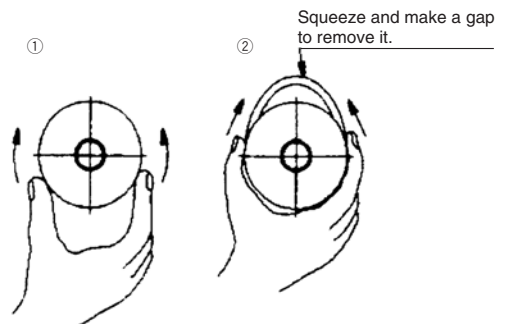

1-8. Replacement of wearing

When wearing is wore-out, remove and replace it with watchmakers screw driver.

Series RHC Replacement Procedure of Seal ②

1-9. Removal of cushion seal

Since cushion seal is mounted on the parts of rod and head cover where groove is machined, remove it carefully with watchmakers screw driver with the same operation for rod seal.

1-10. Each O-ring

Remove each part just in the case that there are flaws on surface of O-ring. Use same operation as piston seal for the small O-ring which mounted on the groove. Put small amount of grease.

1-11. Installation of rod seal

Install rod seal with correct direction after applying grease on whole part. Check if there is no deformation on seal, and if so, set it correctly with finger.

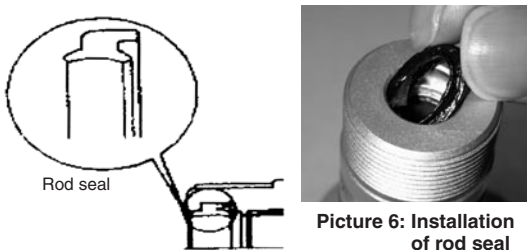

Picture 6: Installation of rod seal

1-12. Installation of cushion seal

Install cushion seal with correct direction after applying grease on whole part. Check if there is no deformation on seal, and if so, set it correctly with finger.

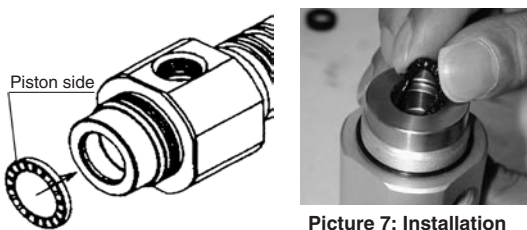

Picture 7: Installation cushion seal

1-13. Installation of piston seal

Install piston seal by expanding it to mounting groove after applying grease on whole part. Then, put grease to outside of piston like below diagram.

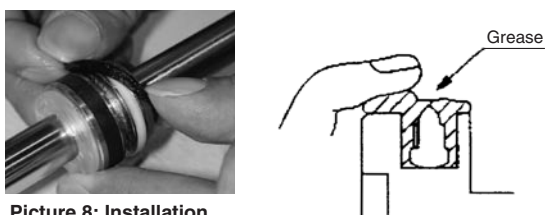

Picture 8: Installation of piston seal

1-14. Grease for piston rod assembly

Spread grease thinly and equally to pointed part stated below.

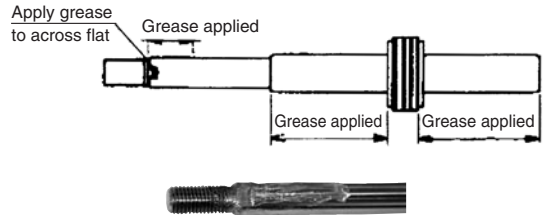

Picture 9: Grease applied piston rod assembly

1-15. Preliminary tightening of tube and cover

Prepare assembly by screwing head cover in tube with hand.

1-16. Grease for sliding portion (I.D.) of tube

Apply grease inside of cylinder tube. Put approx. 1cm (3 g) of grease on finger as standard and apply it to the range, which is equivalent length to cylinder I.D. equally.

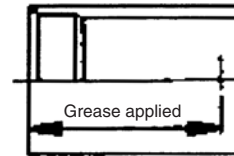

1-17. Insertion of piston rod assembly

Insert piston rod assembly to the assembly in step 1-16. Pay great attention to the operation to protect piston seal from flaws by screw at the end of tube.

1-18. Preliminary tightening of rod cover

Screw-in rod cover to the assembly assembled up to 3-17 with hand. Pay great attention to operation to protect rod seal from flaws by screws on the end of tube.

1-19. Final tightening of cover

Fix head cover with vice and screw-in rod cover with spanner and monkey wrench with the same procedure at disassembly. Tight additionally approx. 1-2° as standard considering the relation of ports between rod cover and head cover before disassembly.

1-20. Installation of relief valve body

Install relief valve body on cover. Install it as rotating until it touch's to the end of cover as facing C chamfer to outside.

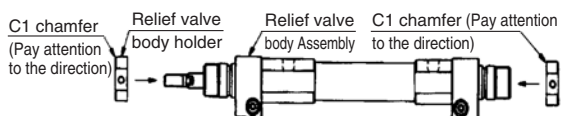

Series *RHC* Replacement Procedure of Seal 3

1-21. Relief valve fixing

Fix hexagon socket set screw with hexagon wrench.
Refer to the following table for tightening torque.

Table 3, Tightening torque (N·m)

Model	Tightening torque
RHC*20	1.5 ± 10%
RHC*25	1.5 ± 10%
RHC*32	2.6 ± 10%
RHC*40	2.6 ± 10%

1-22. Check before cylinder installation

Perform trial operation with min. operating pressure of 0.05 MPa before mounting cylinder to check if each part is not loosened or if there is no air leakage, then check same things at max. operating pressure of 1.0 MPa. After checking no failure on parts, install cylinder.

1. Replaceable Seal

1-1. The seals shown on the below figure are replaceable.

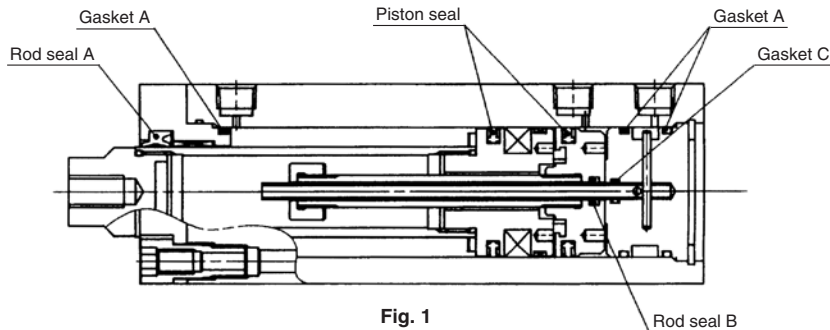

Fig. 1

2. Disassembly of the Cylinder

⚠ Caution

Cylinder needs to be disassembled/assembled at clean environment. Use a clean cloth. Before disassembly, eliminate the dirt on the outer surface so that foreign material does not enter the cylinder or the guide.

2-1. Removing rod cover

Loose the fitting bolts, and remove the rod cover.

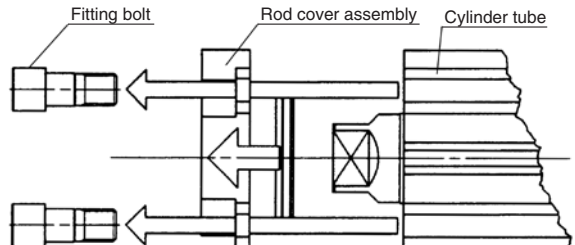

Fig. 2

2-2. Removal of components

Following the removal of a retaining ring, press the tube rod cover out from rod side, and take it out from head side.

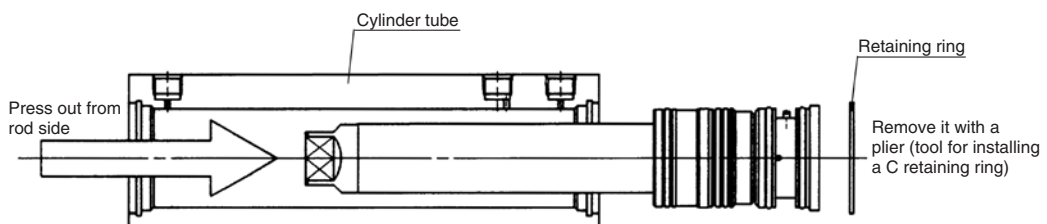

Fig. 3

⚠ Caution

Perform mounting and removal of the retaining ring with a proper plier (tool for installing a C retaining ring). There is a risk of causing damage for human body and peripheral equipment when a retaining ring is removed from the end of plier even if it is a proper plier. Supply air after checking the retaining ring is mounted at the retaining ring groove securely.

Series RZQ Replacement Procedure of Seal 2

2-3. Removal of head cover assembly

Take the head cover assembly out from the piston rod assembly.
(The piston rod assembly cannot be further disassembled.)

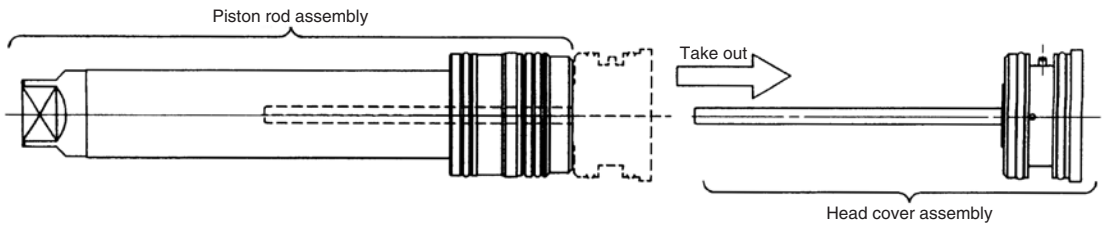

Fig. 4

2-4. Take the parallel pin out from the head cover, and remove the inner pipe.

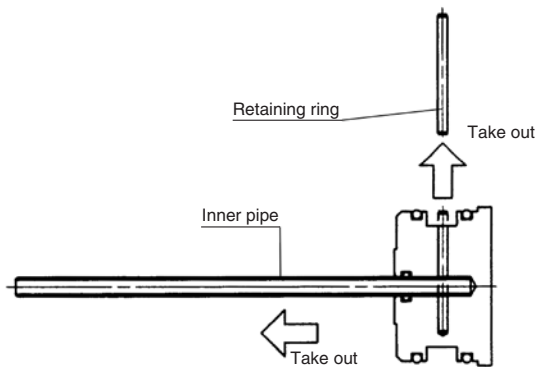

Fig. 5

3. Removal of the Seal

3-1. Removal of rod seal

Remove the seal by inserting a watchmakers screw driver from the front side of the rod cover. During this work, do not give a flaw on the seal groove at the rod cover.

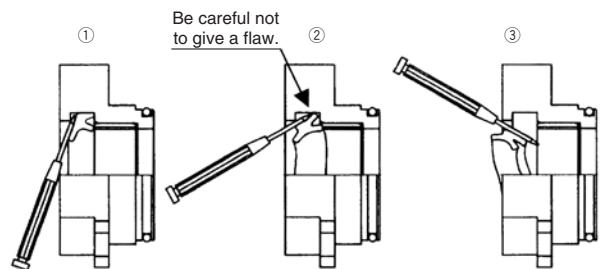

Fig. 6

3-2. Removal of piston seal

- Wipe out grease around the piston seal (it helps easy removal of a piston seal).
- As the piston seal groove is deep, remove the seal using a gap made by squeezing it, not using a precision driver.

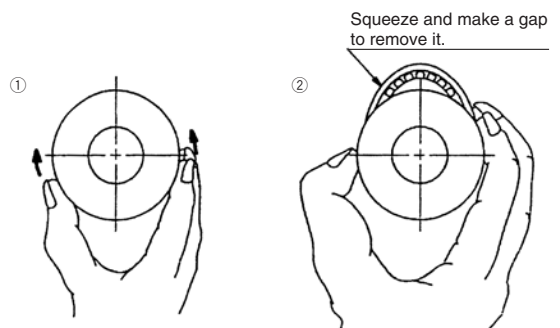

Fig. 7

Series RZQ Replacement Procedure of Seal 3

3-3. Removal of gasket

a. Gasket around rod cover and head cover

In the same way as the removal of piston seal, squeeze the gasket and make a gap to remove it.

b. Gasket inside head cover

In the same way as the removal of rod seal, insert a watchmakers screw driver to remove it. Be careful not to give a flaw on the seal groove at the rod cover.

4. Application of Grease

4-1. Rod seal and piston seal

Apply grease thinly and evenly to the seal for replacement. Fill grease into the groove.

4-2. Gasket

Apply grease thinly and evenly to the gasket for replacement.

4-3. Cylinder parts

Apply grease to each part.

Refer to "6. Assembling of Cylinder" for the parts to apply grease.



Fig. 8

5. Mounting of Seal

5-1. Rod seal

Mount the seal with care of its direction. Apply grease to the seal and the bushing evenly after mounting it as shown on Fig. 9.

Apply grease to the rod seal B with a precision driver.

5-2. Piston seal

Mount the seal without twisted. After mounting it, apply the grease to the seal and the seal groove as shown on Fig. 10.

5-3. Gasket

Fit it up with care of drop off.

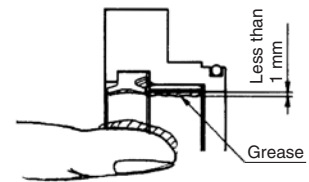

Fig. 9

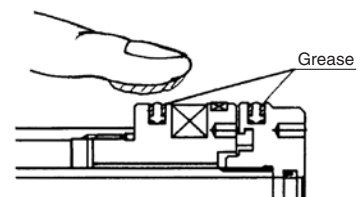

Fig. 10

6. Assembly of the Cylinder

6-1. Apply grease to insertion for head cover at the inner pipe.

6-2. Insert the inner pipe to the head cover. (Match the hole of head cover with the one of inner pipe.) Perform Inserting slowly and carefully so as not to catch the gasket.

6-3. Get the parallel pin through the head cover and the inner pipe.

6-4. Pull the inner pipe lightly to check it will not fall off from the head cover.

6-5. Apply grease to the inner pipe.

6-6. Insert the head cover assembly (inner pipe) to the piston rod assembly. Perform Inserting slowly and carefully so as not to catch the rod seal B.

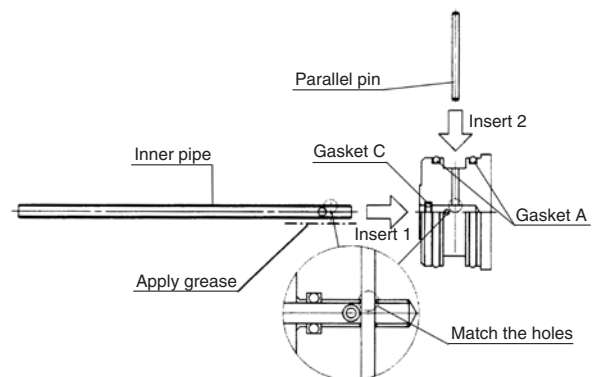

Fig. 11

Series RZQ Replacement Procedure of Seal 4

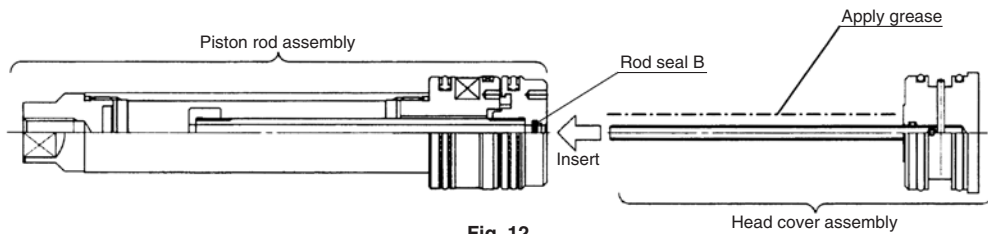

Fig. 12

- 6-7. Apply grease to inside of the cylinder tube and outside of the tube rod, the piston A, and the piston B.
- 6-8. Insert the piston rod assembly and head cover assembly to the cylinder tube. Perform Inserting slowly and carefully so as not to catch the piston seal and the gasket.
- 6-9. Mount a retaining ring on the cylinder tube to fix the head cover.

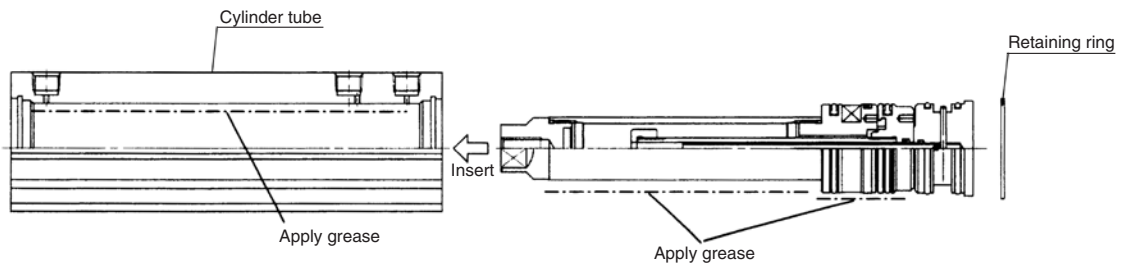

Fig. 13

- 6-10. Apply grease to the internal face of the bushing at the inside of the rod cover.
- 6-11. Insert the rod cover assembly to the cylinder tube. Mount the rod seal A slowly and carefully so as not to be caught.
- 6-12. Apply locking agent to the fitting bolt.
- 6-13. Tighten the fitting bolts at the cylinder tube to fix the rod cover. Refer to Table 1 for the tightening torque of the fitting bolts.

Table 1

Bore size (mm)	Nominal size	Tightening torque [N·m]
32	M8 x 0.75	6.2
40	M8 x 0.75	6.2
50	M10 x 0.75	15.6
63	M12 x 1.0	21.0

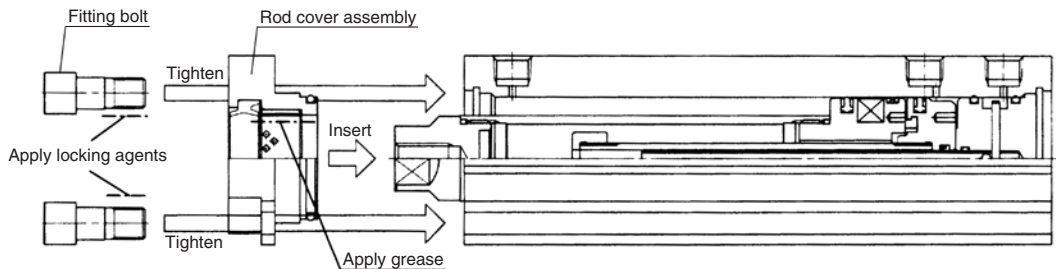

Fig. 14

After completing the assembly, confirm that there is not air leakage from the sealing parts, and also that it operates smoothly with the low operating pressure.

1. Disassembly of the Cylinder

1-1. Cleaning

Prior to disassembly, wipe off any dirt from the outside of the actuator. This will prevent the intrusion of dust and foreign materials during disassembly.

Take particular care on the surface of the piston rod.

1-2. Removal of arm

Remove the arm with rod point.

1-3. Removal of hexagon socket head cap screw [only $\phi 25$ or more]. (Fig. 1)

Remove the hexagon socket head cap screw (with washer or spring washer).

1-4. Removal of retaining ring (Fig. 2)

Remove with proper pliers (tool for basic internal retaining ring). Moreover, please note that the retaining ring comes off from pliers when detaching it, it files, and the human body and peripherals might be disadvantaged.

1-5. Disassembly

Install the bolt etc. in the point part of the piston rod, and pull it out with rod cover assembly and the key.

In that case, please note that neither the inside diameter of the tube nor the rod cover bearing are damaged.

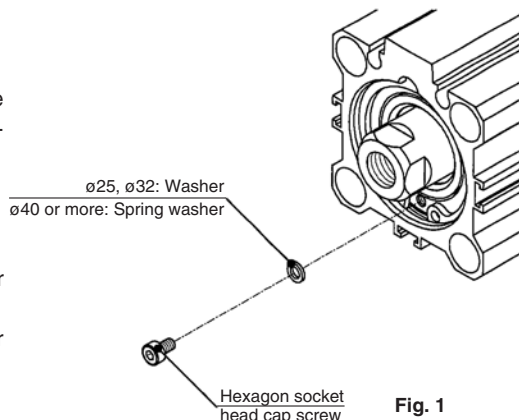

Fig. 1

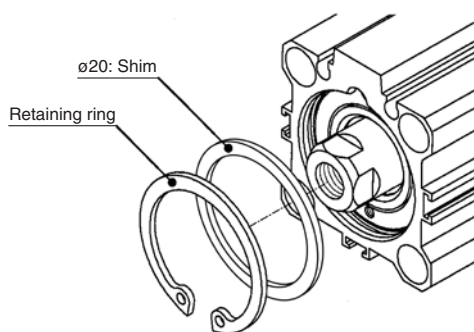

Fig. 2

2. Removal of the Seal

2-1. Removal of the coil scraper

Insert a precision driver etc. from front the rod cover assembly and prise the seal out. From front rod cover assembly and prise the coil scraper out.

Take care not to scratch or score the coil scraper groove in the rod cover assembly.

2-2. Removal of the rod seal

Insert a precision driver etc. from front the rod cover assembly and prise the seal out.

Take care not to scratch or score the seal groove in the rod cover assembly.

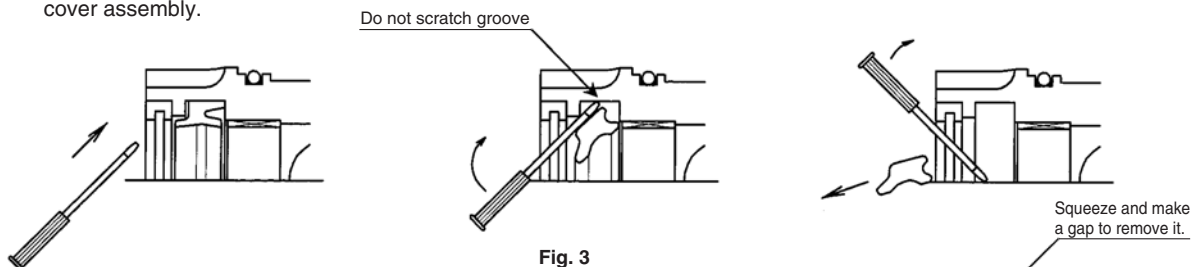

Fig. 3

2-3. Removal of the piston seal

As the piston seal groove is deep, remove the seal using a gap made by squeezing it, not using a precision driver.

2-4. Removal of the tube gasket

Squeeze the gasket and make a gap to remove it. (Refer to the right Fig. 4).

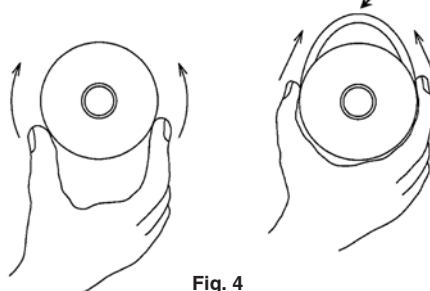

Fig. 4

3. Application of Grease

3-1. Grease spreading of rod seal and piston seal (Fig. 5)

There is thinly no irregularity and lithium system grease* is spread on all surroundings of rod seal and piston seal for the exchange.

*SMC recommendation grease: It is possible to arrange. (Refer to the operation manual.)

3-2. Grease spreading of tube gasket

There is thinly no irregularity and lithium system grease* is spread on the whole of the tube gasket for the exchange.

*SMC recommendation grease: It is possible to arrange. (Refer to the operation manual.)

3-3. Grease spreading of each part

There is thinly no irregularity and lithium system grease* is spread on a specified part of rod cover assembly, piston rod assembly and cylinder tube assembly.

*SMC recommendation grease: It is possible to arrange. (Refer to the operation manual.)

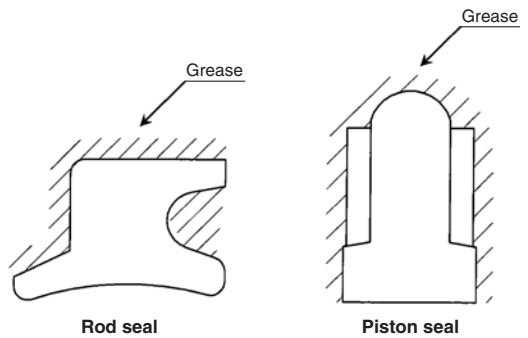

Fig. 5

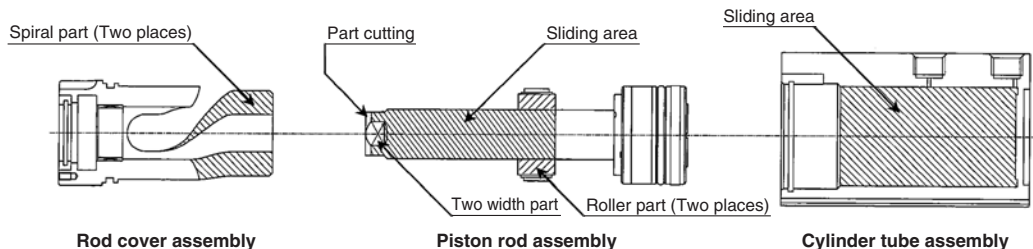

Fig. 6

4. Installation of Seal and Coil Scraper

4-1. Installation of rod seal and tube gasket (Fig. 7)

Install the direction of rod seal so as not to make a mistake. Install the tube gasket so as not to drop out of rod cover assembly.

After it installs it, there is no irregularity and lithium system grease* is spread on rod seal and the bearing.

*SMC recommendation grease: It is possible to arrange. (Refer to the operation manual.)

4-2. Installation of coil scraper

Install coil scraper for the exchange in the coil scraper ditch surely.

4-3. Installation of piston seal (Fig. 8)

Install it so that piston seal should not twist.

Spread it to rub lithium system grease* into between piston seal outer part and the ditch after it installs it.

*SMC recommendation grease: It is possible to arrange. (Refer to the operation manual.)

4-4. Installation of tube gasket

Please note the dropout, and install it.

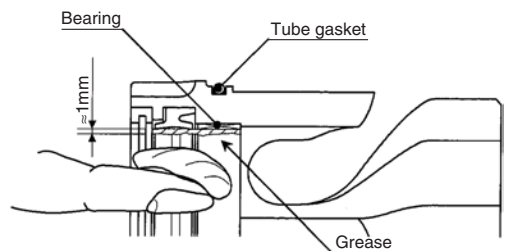

Fig. 7

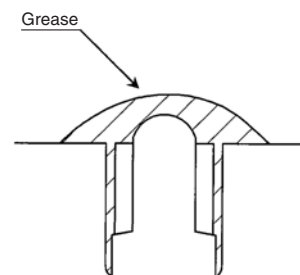

Fig. 8

5. Assembly of the Cylinder

5-1. Insertion of rod cover assembly (Fig. 9)

Insert it politely slowly so as not to damage rod seal in corner part piston rod assembly.

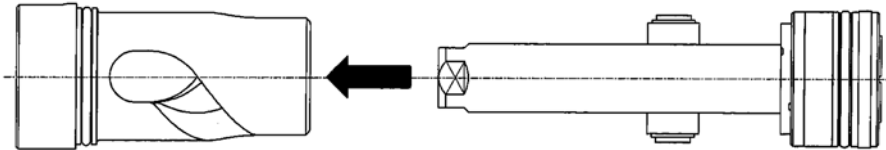

Fig. 9

5-2. Insertion of piston rod assembly (Fig. 10)

Insert it politely slowly to damage neither piston seal nor the tube gasket in corner part cylinder tube assembly.

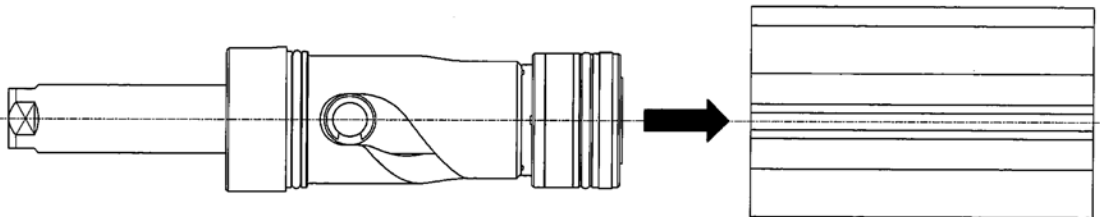

Fig. 10

5-3. Installation of key and retaining ring (Fig. 11)

Insert the key in the key ditch, and install the retaining ring with proper pliers (tool for basic internal retaining ring).

In that case, install the direction of the retaining ring so as not to make a mistake.

Because the retaining ring comes off from pliers when it installs it, it flies, and the human body and peripherals might be disadvantaged. Please note it.

Moreover, please confirm whether in the retaining ring ditch surely.

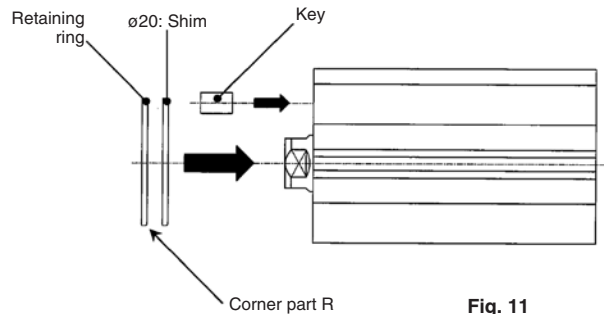

Fig. 11

5-4. Installation of hexagon socket head cap screw [only ø25 or more] (Fig. 12)

After cleaning the adhesive from the hexagon socket head cap screw and the rod cover assembly with alcohol etc., apply the tightening adhesive to the screw holes of the rod cover assembly (SMC recommended adhesive: Loctite Corp. 242 [Blue]) in order not to loose. Spread the adhesive (SMC recommendation adhesive: Loctite Corp. 242 [Blue]) for loose stop on screw hole part rod cover assembly.

Tighten with the hexagon socket head cap screw (*ø25, ø32: with washer/ø40 or more: with spring washer).

Please confirm whether the adhesive has overflowed after it concludes it.

Wipe an extra adhesive off when overflowing.

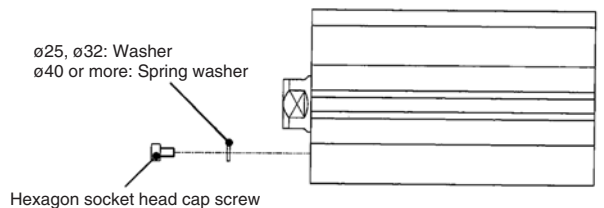

Fig. 12

Tightening torque

Bore size	Size of screw	Tightening torque (N·m)
ø25, ø32	M2.5 x 0.45	0.36 ± 10% (0.324 to 0.396)
ø40, ø50, ø63	M3 x 0.5	0.63 ± 10% (0.570 to 0.690)

5-5. Assembly confirmation

Please confirm whether not to cause the air leakage from the packing seal or to operate by the minimum operating pressure smoothly.

⚠ Caution

1. Confirm air is not supplied for the cylinder before disassembly and reassembly.

2. Never disassemble lock unit [For only CLKQG/CLKQP series]

The lock unit is equipped with heavy duty spring and may cause danger if disassembled.

Also, if it is reassembled incorrectly, the locking performance is impaired and desired function become unavailable.

For these reasons, the disassembly of lock unit at customer's site is prohibited strictly.

(If disassembly or replacement of a part is required absolutely, contact SMC.)

1. Removal of Spatter

a. Insert flat blade screwdriver into the groove of cover and set up the cover straight toward direction marked with arrows by the driver. Then the cover is opened.

* If excessive force is given to do this, the cover may be damaged.

b. Collect the spatter inside the groove.

c. Push the cover unit it snaps.

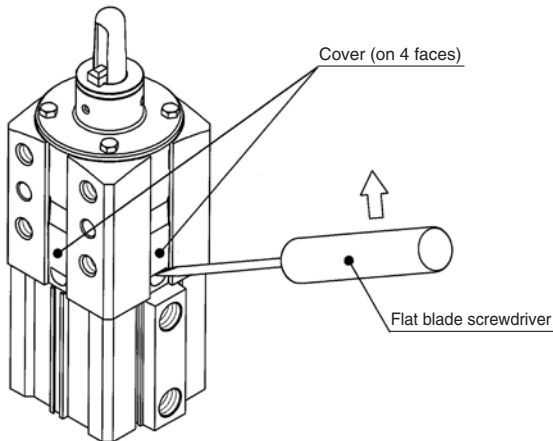

2. Replacement of Guide Pin and Clamp Arm

The clamping position height: For the LOW type

1. Disassembly of clamping part

a. Cleaning of appearance

Wipe off the dirt of appearance to prevent intrusion of dust and foreign materials during disassembly.

b. Removal of guide pin assembly.

Adjust the position of the clamp arm to the unclamping side, detach the hexagon socket set screw (3 pcs.), and guide pin assembly from guide tube.

Detach the parallel pin which does a positional match of guide tube and guide pin assembly.

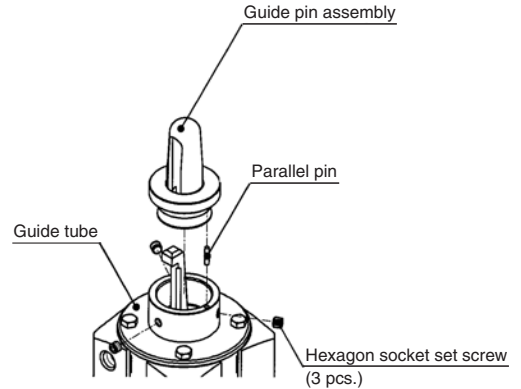

c. Removal of clamp arm

1) Detach the hexagon head bolt (4 pcs.), and detach the guide tube from the body.

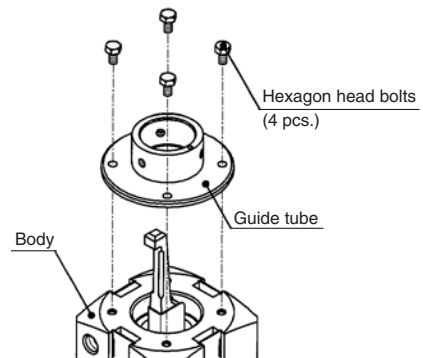

2) Insert a flat blade screwdriver or similar object into the cover groove and open. Then detach the cover (4 pcs.).

Detach pin A from the body side hole.

Pay attention to cut neither the hand nor the finger, etc. when you detach the cover.

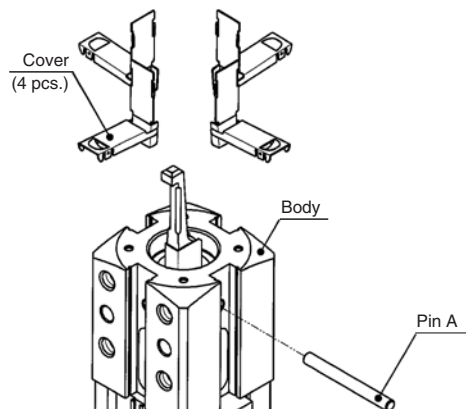

Series CKQG/CKQP Replacement Procedure of Seal 2

- 3) Loosen the hexagon socket head cap screw (4 pcs.) the base cylinder, and detach the body from the base cylinder.

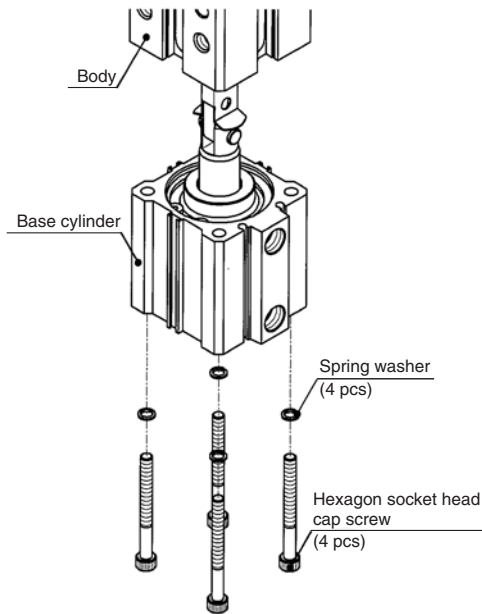

- 4) Extract the cotter pin, detach pin B, and detach the clamp arm (The spatter cover also together).

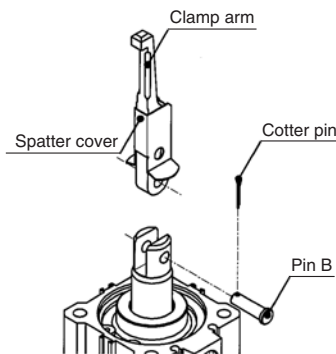

2. Reassembly of clamping part

a. Check of part no.

Check the number printed on clamp arm and guide pin assembly with reference to the following table.

	Printed no.	
	Guide pin assembly	Clamp arm
Applicable combination	125, 127, 128, 129, 130	13
	145, 147, 148, 149, 150	15-16
	155, 157, 158, 159, 160	15-16
	175, 177, 178, 179, 180	18
	195, 197, 198, 199, 200	20
	245, 247, 248, 249, 250	25
	295, 297, 298, 299, 300	30

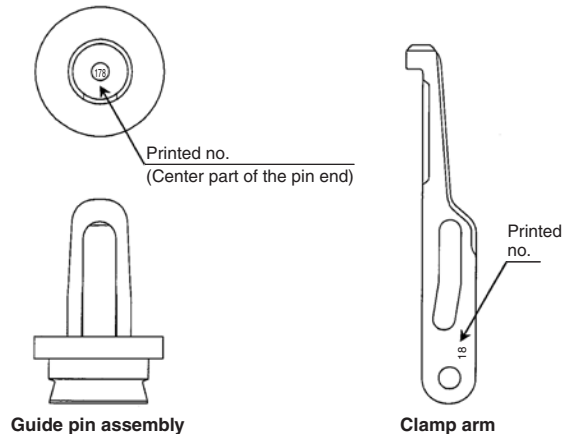

b. Mounting of clamp arm

- 1) There is thinly no irregularity and lithium system grease is spread on the slash part of the clamp arm for the exchange (both sides). Moreover, there is no irregularity and lithium system grease is spread on the pin hole part and the cam ditch part of the clamping arm a lot (Grease can collect).

Install the spatter cover (The direction is noted) in the clamping arm.

In that case, install it so that the pin hole of the spatter cover and the cam groove of the clamp arm are visible.

Grease application amount (standard)

Both sides of clamping arm	≈ 0.05 g
Clamp arm pin hole part	≈ 0.10 g
Clamp arm cam ditch part	≈ 0.50 g

- 2) There is thinly no irregularity and lithium system grease is spread on the slash part in pin B and the piston rod slit part (both sides).

Moreover, there is no irregularity and lithium system grease is spread on the piston rod pin hole part a lot (Grease can collect).

Do not damage the finger etc. for the acute angle when you spread grease on the piston rod slit part.

Grease application amount (standard)

Pin B	≈ 0.05 g
Piston rod slit part	≈ 0.05 g
Piston rod slit part	≈ 0.10 g

- 3) Insert the clamp arm (with spatter cover) in the piston rod slit part and insert pin B.

Insert the cotter pin for the exchange through the hole for the cotter pin of pin B, and bend the point with the needle rose pliers.

- 4) Rotate the clamp arm, and rotate it so that the A-D installation position may squarely become direction of the fingernail.

(Rotate it while moving the piston rod up and down when it rotates.)

Actuators

Modular F.R.L.
Pressure Control Equipment

Air Preparation
Equipment

Industrial Filters

Replacement
Procedure

Actuators

Modular F.R.L.
Pressure Control Equipment

Industrial Filters

Series CKQG/CKQP Replacement Procedure of Seal 3

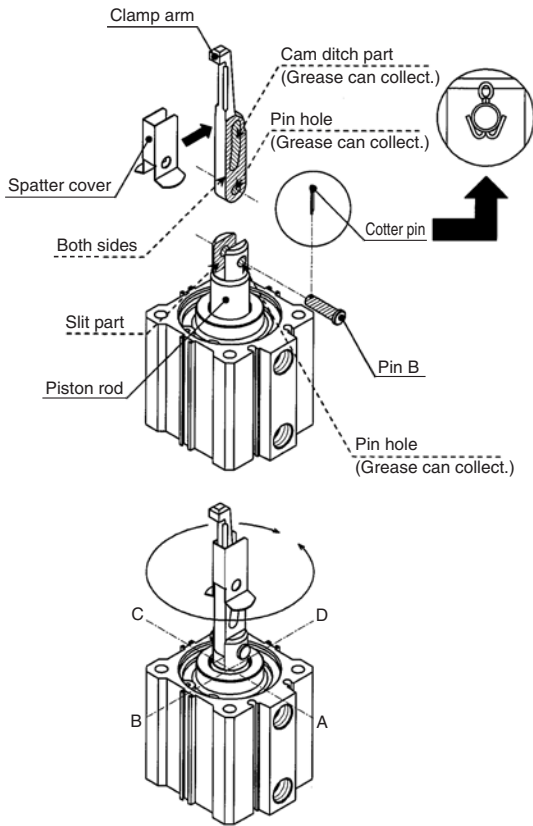

c. Mounting of guide pin assembly

- Put into the state to draw out the piston rod, confirm the body installation side and the clamping arm fingernail position, and insert the body. There is thin irregularity and lithium system grease is spread on the slash part of pin A. There is no irregularity and lithium system grease is spread on the body side hole part (pin A insertion part) a lot (Grease can collect). Insert pin A from the body side hole through the spatter cover and the clamp arm (Refer to a detail chart).

Grease application amount (standard)

Pin A	≈ 0.05 g
Body side hole part	≈ 0.20 g

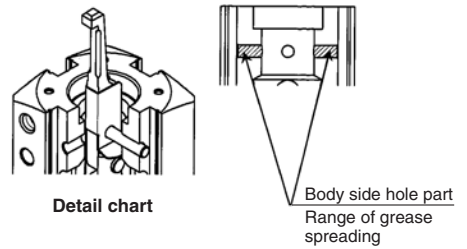
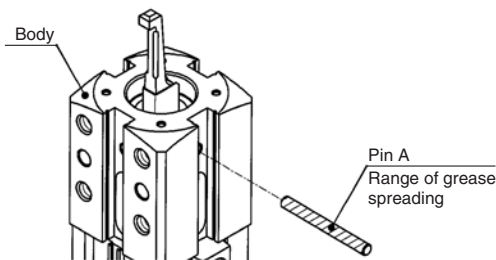

- Fasten, in order, the spring washer (4 pcs.) and the hexagon socket head cap screw (4 pcs.) from the head side of the base cylinder. Tightening torque: 4 to 6 (N·m)

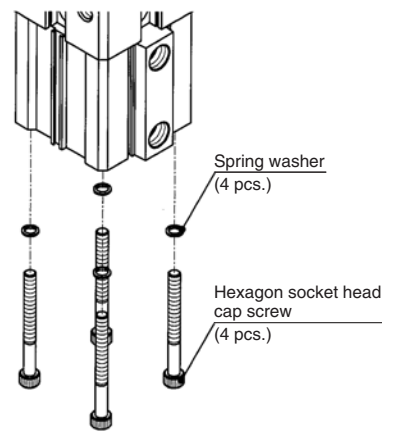

- Install the cover (4 pcs.) on the body. In that case, please note the direction of insertion.

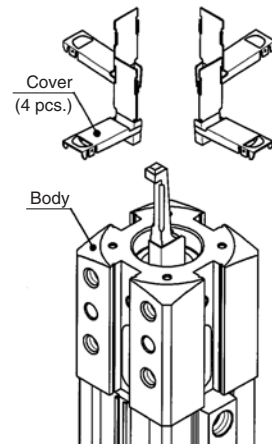

Series CKQG/CKQP Replacement Procedure of Seal 4

4) After cleaning the adhesive from the hexagon head bolts (4 pcs.) and the body with alcohol etc., apply the tightening adhesive to the screw holes of the body (SMC recommended adhesive: Loctite Corp. 242 [Blue]) in order not to loose. Please install the guide tube in the body with the hexagon head bolt (4 pcs.).

In that case, install it so the guide tube pin hole is on the right side of the clamp arm (detail chart).
Tightening torque: 1.5 to 1.8 (N·m)

Please confirm whether the adhesive has overflowed after concluding the hexagon head bolt (4 pcs.).

Wipe an extra adhesive off when overflowing.

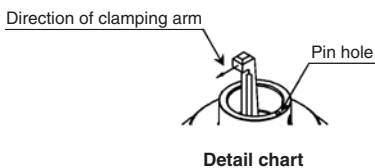
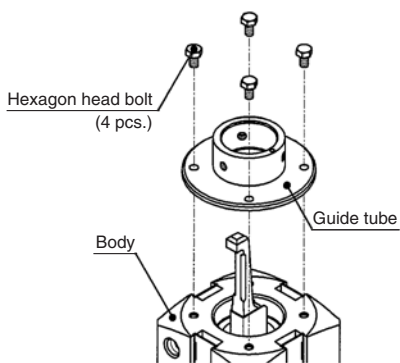

5) Insert the parallel pin for the exchange in the pin hole of guide pin assembly for the exchange, (when equipped with a shim, adhesive to secure the parallel pin to the guide pin assembly) suit to the position of the pin hole on the guide tube side, insert, and tighten with the hexagon socket set screw (3 pcs.: [green] with the adhesive).
Tightening torque: 4.86 to 5.94 (N·m)

However, when the adhesive color of the hexagon socket set screw (3 pcs.) is "red", or the "green" adhesive is stripped off from repeated replacements, completely remove the remaining adhesive from the thread of the hexagon socket set screw and the screw hole of the guide tube with alcohol. Then apply tightening adhesive (SMC recommendation: Loctite Corp. 242 [Blue]) to the hexagon socket set screw (3 pcs.).
Please confirm whether the adhesive has overflowed after it concludes it.

Wipe an extra adhesive off when overflowing.

For the with shim type, insert the shim between the guide pin assembly and the guide tube.

Install the order of shim referring to the following. Please confirm shim does not dash out from the guide tube outer after assemble.

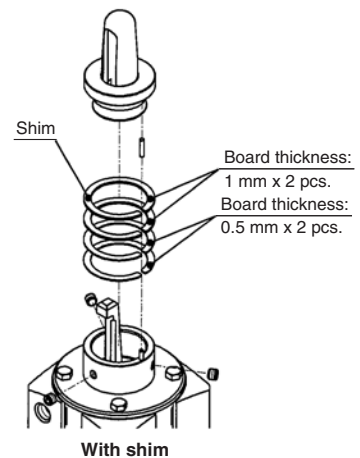
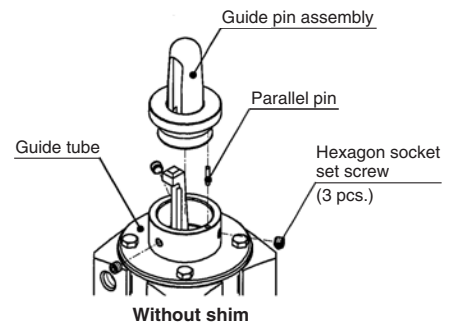

Actuators

Modular F.R.L.
Pressure Control Equipment

Air Preparation
Equipment

Industrial Filters

Replacement
Procedure

Actuators

Modular F.R.L.
Pressure Control Equipment

Industrial Filters

The Clamping Position Height: For HIGH

1. Disassembly of clamping part

a. Cleaning of appearance

Wipe off the dirt of appearance to prevent intrusion of dust and foreign materials during disassembly.

b. Removal of guide pin assembly

Adjust the position of the clamp arm to the unclamping side, detach the hexagon socket set screw (3 pcs.), and guide pin assembly from the guide tube. Detach the parallel pin which does a positional match of guide tube and guide pin assembly.

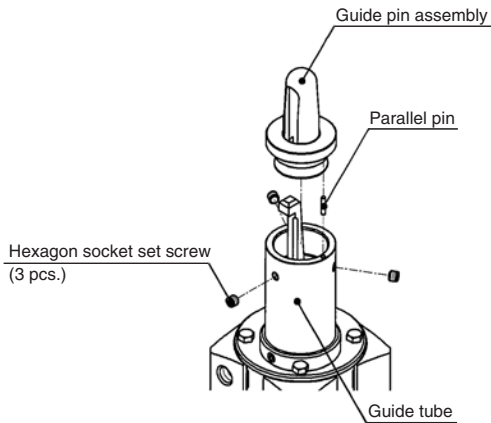

c. Removal of clamp arm

1) Detach the hexagon socket set screw, and detach the ring from the guide tube.

Detach pin A from the guide tube side hole.

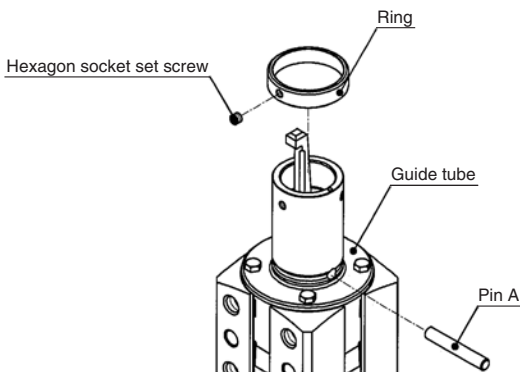

2) Detach the hexagon head bolt (4 pcs.), and detach the guide tube and the spatter cover from the body.

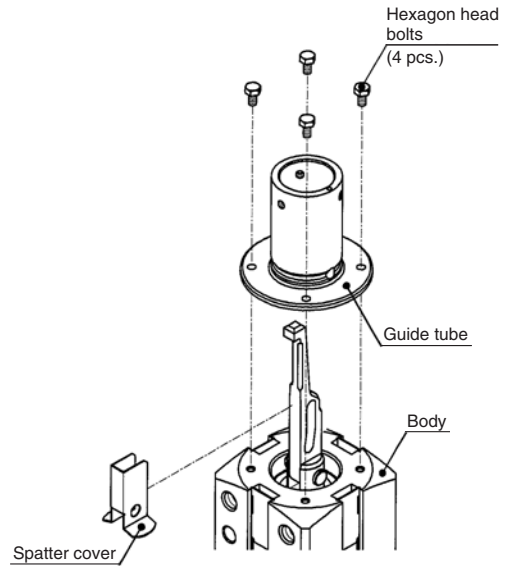

3) Insert a flat blade screwdriver or similar object into the cover groove and open. Then detach the cover (4 pcs.).

Pay attention to cut neither the hand nor the finger, etc. when you detach the cover.

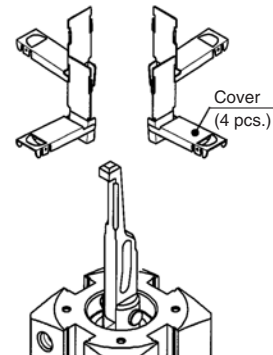

Series CKQG/CKQP Replacement Procedure of Seal 6

- 4) Loosen the hexagon socket head cap screw (4 pcs.) of the base cylinder, and detach the body from the base cylinder.

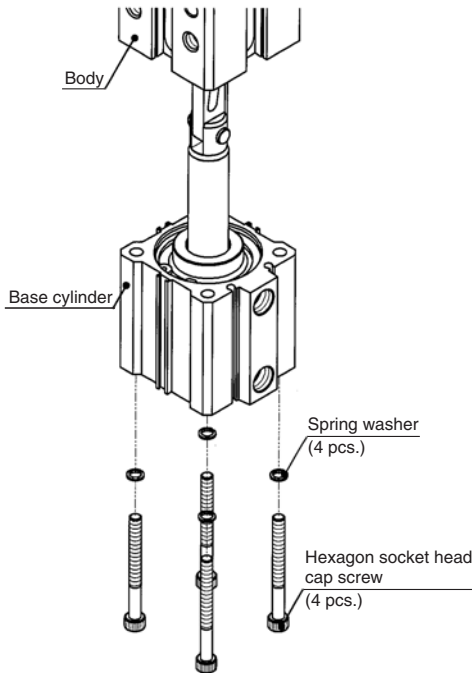

- 5) Extract the cotter pin, detach pin B, and detach the clamp arm.

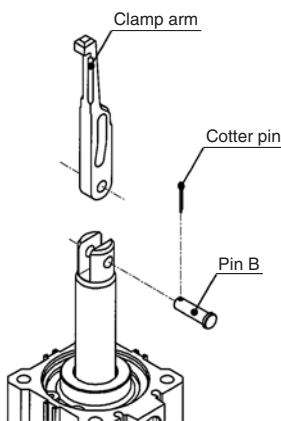

2. Reassembly of clamping part
a. Check of part no.

Check the number printed on clamp arm and guide pin assembly with reference to the following table.

	Printed no.	
	Guide pin assembly	Clamp arm
Applicable combination	125, 127, 128, 129, 130	13
	145, 147, 148, 149, 150	15-16
	155, 157, 158, 159, 160	15-16
	175, 177, 178, 179, 180	18
	195, 197, 198, 199, 200	20
	245, 247, 248, 249, 250	25
	295, 297, 298, 299, 300	30

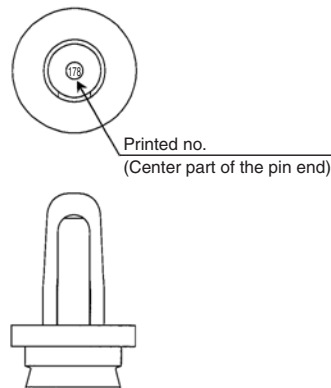

Guide pin assembly

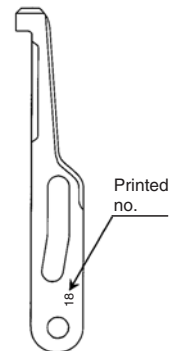

Clamp arm

- b. Installation of clamp arm

- 1) There is thinly no irregularity and lithium system grease is spread on the slash part of the clamp arm for the exchange (both sides). Moreover, there is no irregularity and lithium system grease is spread on the pin hole part and the cam ditch part a lot (Grease can collect).

Grease application amount (standard)

Both sides of clamp arm	≈ 0.05 g
Clamp arm pin hole part	≈ 0.10 g
Clamp arm cam ditch part	≈ 0.50 g

- 2) There is thinly no irregularity and lithium system grease is spread on the slash part in pin B and the piston rod slit part (both sides). There is no irregularity and lithium system grease is spread on the piston rod pin hole part a lot (Grease can collect). Do not damage the finger etc. in the slit part for the acute angle when you spread grease on the piston rod slit part.

Grease application amount (standard)

Pin B	≈ 0.05 g
Piston rod slit part	≈ 0.05 g
Piston rod pin hole part	≈ 0.10 g

Series CKQG/CKQP Replacement Procedure of Seal 7

- 3) Insert the clamp arm in the piston rod slit part and insert pin B.

Insert the cotter pin for the exchange through the hole for the cotter pin of pin B, and bend the point with the radio pincers.

- 4) Rotate the clamp arm, and rotate it to become it at right angles with the A-D installation position and the direction of the fingernail.
(Rotate it while moving the piston rod and down when it rotates.)

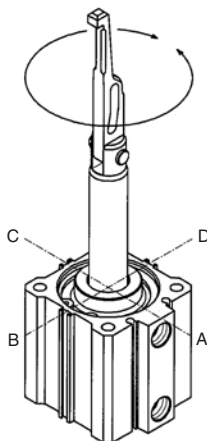
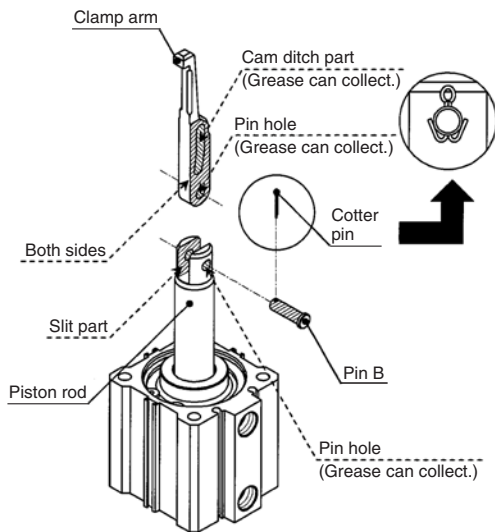

c. Mounting of guide pin assembly

- 1) Put into the state to draw out the piston rod, confirm the body installation side and the clamp arm fingernail position, and insert the body.
Fasten, in order, the spring washer (4 pcs.) and the hexagon socket head cap screw (4 pcs.) from the head side of the base cylinder.
Tightening torque: 4 to 6 (N·m)

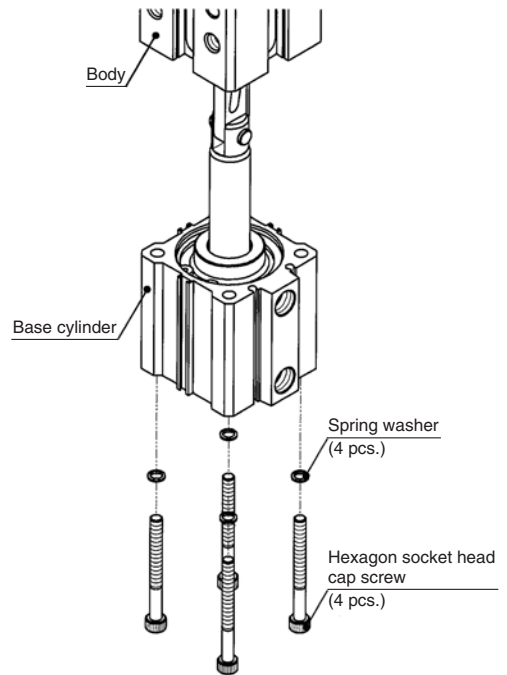

- 2) Install the cover (4 pcs.) on the body. In that case, please note the direction of insertion.

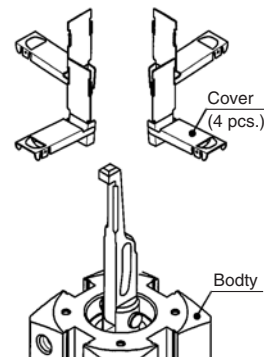

- 3) After cleaning the adhesive from the hexagon head bolts (4 pcs.) and the body with alcohol etc., apply the tightening adhesive to the screw holes of the body (SMC recommended adhesive: Loctite Corp. 262 [Red]) in order not to loose. Spread lithium system grease on the pin hole part of pin A and the guide tube.

Grease application amount (standard)

Pin A	≈ 0.05 g
Guide tube pin hole part	≈ 0.10 g

Series CKQG/CKQP Replacement Procedure of Seal 8

Install the spatter cover (The direction is noted) in the clamp arm.

In that case, install it so that the pin hole of the spatter cover and the cam groove of the clamp arm are visible.

Insert the guide tube in the body.

In that case, install it so the guide tube pin hole is on the right side of the clamp arm (detail chart).

Insert pin A from the guide tube side hole through the spatter cover and the clamp arm (Refer to detail chart 2).

Install it with the hexagon head bolt (4 pcs.) after inserting pin A. Tightening torque: 1.5 to 1.8 (N·m).

Please confirm whether the adhesive has overflowed after concluding the hexagon head bolt (4 pcs.).

Wipe an extra adhesive off when overflowing.

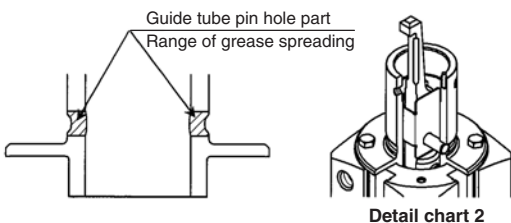
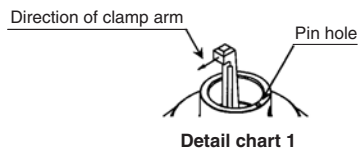
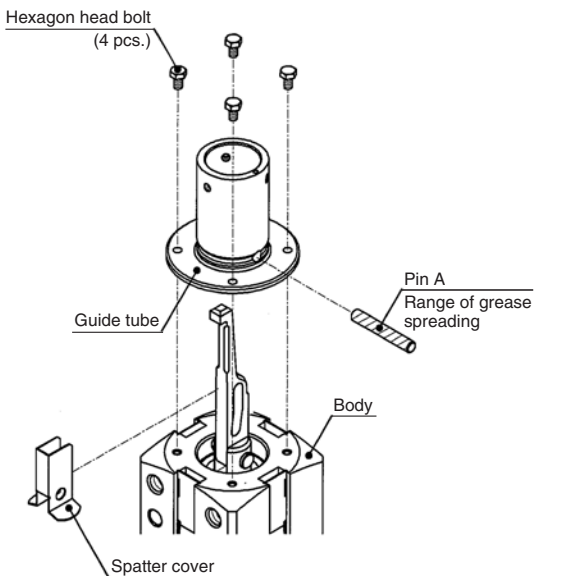

4) Insert the ring in the guide tube and install it with a hexagon socket set screw (with the adhesive [Green]).

Align the screw hole position of the ring to the same direction of the clamp arm claw and tighten.

(Refer to the figure below.)

Tightening torque: 4.86 to 5.94 (N·m)

However, when the adhesive color of the hexagon socket set screw is "red", or the "green" adhesive is stripped off from repeated replacements, completely remove the remaining adhesive from the thread of the hexagon socket set screw and the screw hole of the guide tube with alcohol. Then apply tightening adhesive (SMC recommendation: Loctite Corp. 242 [Blue]) to the hexagon socket set screw (3 pcs.).

Please confirm whether the adhesive has overflowed after it concludes it.

Wipe an extra adhesive off when overflowing.

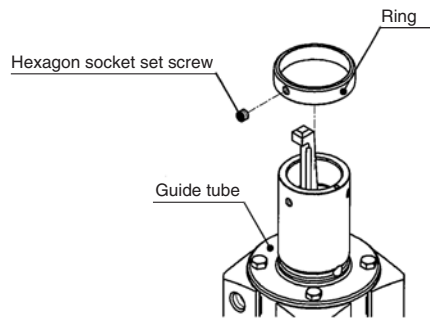

Actuators

Modular F.R.L.
Pressure Control Equipment

Air Preparation
Equipment

Industrial Filters

Replacement
Procedure

Actuators

Modular F.R.L.
Pressure Control Equipment

Industrial Filters

5) Insert the replacement parallel pin in the pin hole of the replacement guide assembly (when equipped with a shim, secure with adhesive on the parallel pin and the guide pin assembly), line up with the pin hole on the guide tube, insert, and tighten with the hexagon socket set screw (3 pcs.: with the adhesive [Green]).

Tightening torque: 4.86 to 5.94 (N·m)

However, when the adhesive color of the hexagon socket set screw (3 pcs.) is "red", or the "green" adhesive is stripped off from repeated replacements, completely remove the remaining adhesive from the thread of the hexagon socket set screw and the screw hole of the guide tube with alcohol. Then apply tightening adhesive (SMC recommendation: Loctite Corp. 242 [Blue]) to the hexagon socket set screw (3 pcs.).

Please confirm whether the adhesive has overflowed after it concludes it.

Wipe an extra adhesive off when overflowing.

For the with shim type, insert the shim between the guide pin assembly and the guide tube. Install the order of shim referring to the following. Please confirm shim does not dash out from the guide tube outer after assemble.

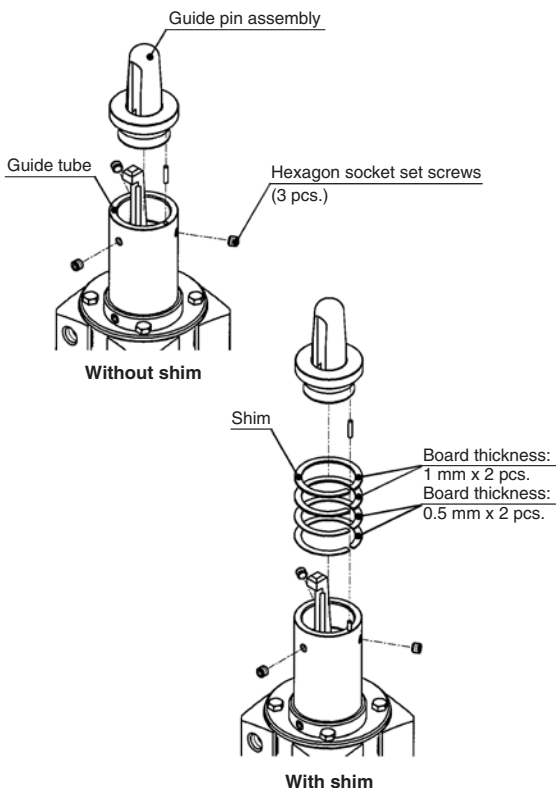

3. Replacement of Seal

(Only for Series CKQG/P because disassembly of CLKQG/P is unacceptable.)

3-1. Disassembly of base cylinder

a. Cleaning of appearance

Wipe off the dirt of appearance to prevent intrusion of dust and foreign materials during disassembly.

Intensively, pay attention to surface of piston rod and collar.

b. Removal of retaining ring

Use adequate pliers (tool for installing a basic internal ring).

And pay attention not to cause the retaining ring to pop out and damage the human body and peripheral equipments.

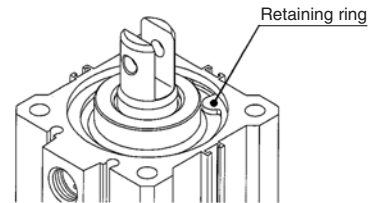

c. Disassembly

Take off the piston rod with collar assembly by pulling out the pin inserted into the hole on the end of piston rod and then remove the collar assembly from the piston rod assembly.

At the time, pay attention not to give any flaw on inner face of the tube and bearing of the collar assembly.

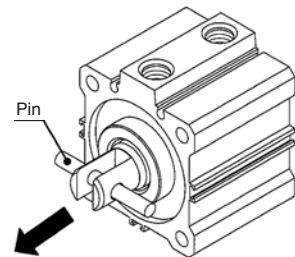

Series CKQG/CKQP Replacement Procedure of Seal 10

3-2. Removal of seal

a. Removal of rod seal

Remove by watchmakers screw driver inserted from the front of collar assembly.

Do not give any flaw on the groove of the collar assembly packing.

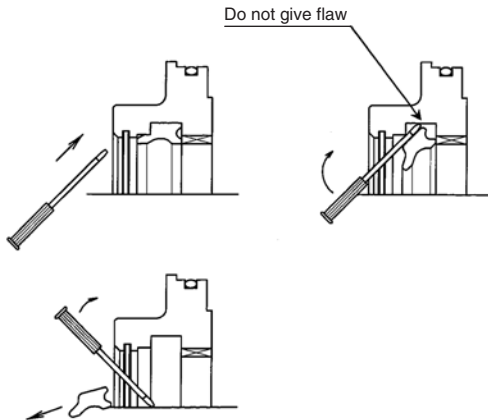

b. Removal of piston seal

As the piston seal groove is deep, remove the seal using a gap made by squeezing it, not using a precision driver.

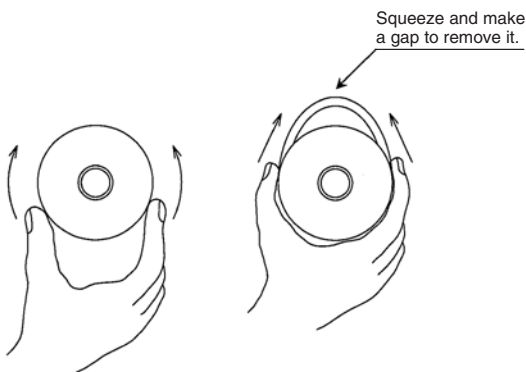

c. Removal of tube gasket

Push the packing gasket partially to make it come off and pull it out manually.

Squeeze the gasket and make a gap to remove it. (Refer to the above figure.)

3-3. Application of grease

a. Rod seal and piston seal

There is thinly no irregularity and lithium system grease is spread on all surroundings of rod seal and piston seal for the exchange.

Grease application amount (standard)

Rod seal	≈ 0.10 g
Piston seal	≈ 0.30 g

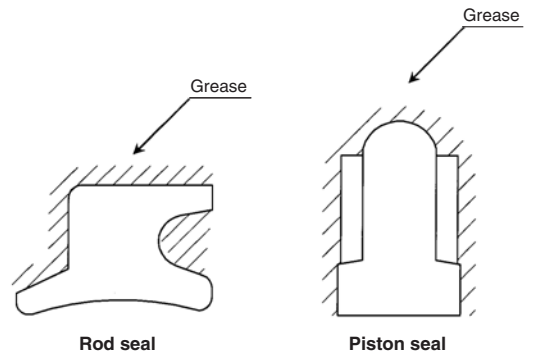

b. Tube gasket

There is thinly no irregularity and lithium system grease is spread on the whole of the tube gasket for the exchange.

Grease application amount (standard)

Tube gasket	≈ 0.15 g
-------------	----------

c. Each components of cylinder

There is thinly no irregularity and lithium system grease is spread on a specified part of piston rod assembly and cylinder tube assembly.

Grease application amount (standard)

Sliding part and taper of piston rod	L type	≈ 0.20 g
	H type	≈ 0.30 g
Sliding part of cylinder tube		≈ 0.40 g

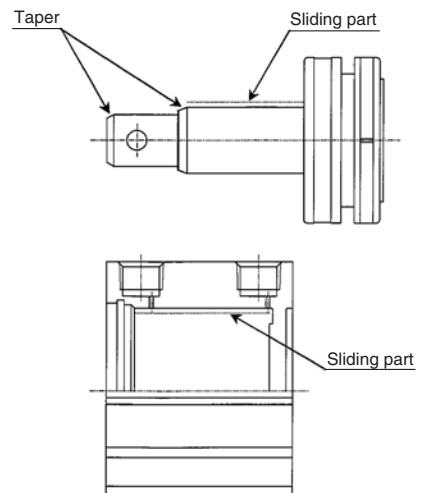

Series CKQG/CKQP Replacement Procedure of Seal 11

3-4. Mounting of seal

a. Mounting of rod seal

Mount the seal with attention to direction.

After installation, apply lithium type grease evenly onto the rod seal and bearing.

Grease application amount (standard)

Rod seal and bearing	≈ 0.25 g
----------------------	----------

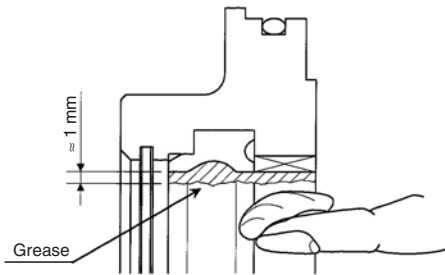

b. Mounting of piston seal

Mount the piston seal without twist.

Spread it to rub lithium system grease into between piston seal outer part and the ditch after it installs it.

Grease application amount (standard)

Piston packing outer part and ditch	≈ 0.70 g
-------------------------------------	----------

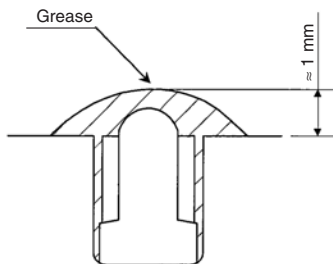

c. Mounting of tube gasket

Pay attention not to make the gasket come off.

3-5. Reassembly of cylinder

a. Insertion of piston rod assembly

Insert it politely slowly so as not to damage rod seal in corner part cylinder tube assembly.

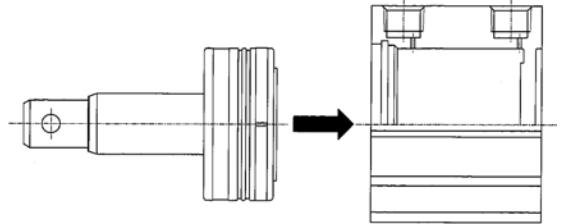

b. Insertion of color assembly

Damage neither rod packing nor the tube gasket in corner part piston rod assembly and cylinder tube assembly. Insert it politely slowly.

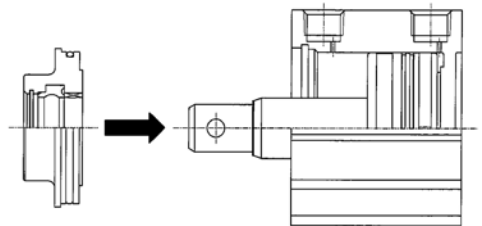

c. Mounting of retaining ring

Use adequate pliers (tool for installing a basic internal ring).

Mount the retaining ring with attention to direction.

And pay attention not to cause the retaining ring to pop out and damage the human body and peripheral equipments.

After mounting, confirm the retaining ring is secured firmly by the mating hole.

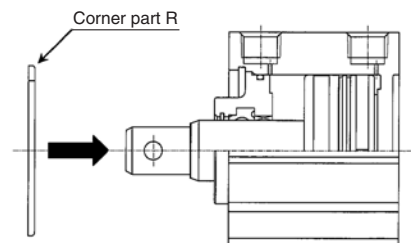

d. Check of reassembly condition

Confirm there is no air leakage from seal etc. and the cylinder can be moved smoothly at min. operating pressure.

1. Disassembly and Assembly of the cylinder

Disassemble and assemble the cylinder in a clean area. Perform on a clean cloth.

For disassembling, hold the flats of the tube cover gently in a vice and hold the flats of the rod cover with a spanner or monkey wrench to loosen and remove the rod cover. When reassembling, tighten 2 degrees more than the original position before disassembling.

2. Removal of the Seal

2-1. Rod seal

Tool: Watchmakers screw driver, etc.

Insert a precision screwdriver from the front side of the cover as shown in Figure 1.

At this time, exercise care not to damage the packing groove of the cover.

2-2. Piston seal

Wipe off grease around piston seal first to make removal easier.

Hold piston seal with one hand and push it into groove so that piston seal can be lifted off and pulled out without using a watchmakers screw driver. (Fig. 2)

2-3. Tube gasket

Remove the tube gasket with the watchmakers screw driver or the like.

3. Application of Grease

3-1. Rod seal

Thinly apply grease to the periphery of a new seal before replacement. Grease will help tight fitting to the cover.

Fill the seal groove with grease for smooth movement. (Fig. 3)

3-2. Piston seal

Apply grease thinly and evenly to the external and internal peripheries of the piston packing to ensure easy fitting to the piston.

3-3. Tube gasket

Thinly apply grease to the tube gasket. Grease will help prevention of dropping off during fitting the cylinder.

3-4. Cylinder parts

Apply grease to all points of cylinder parts as shown in Figure 4.

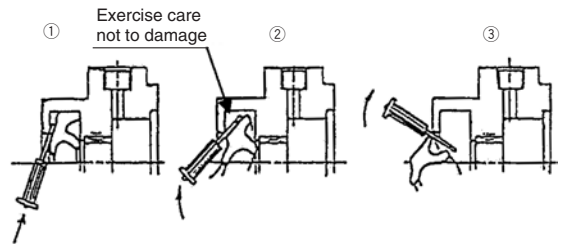

Fig. 1 Removal of rod seal

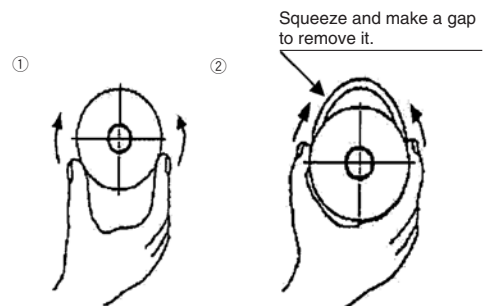

Fig. 2 Removal of piston seal

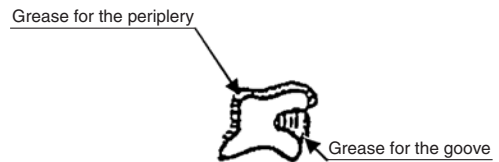

Fig. 3

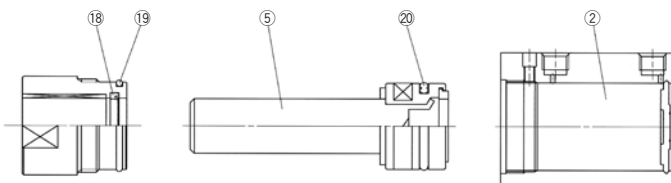

Fig. 4 Grease application points

4. Mounting of Seal

4-1. Rod seal

Mount the rod seal in the correct direction. After this, apply grease to the seal and the entire internal periphery of the bushing as shown in Figure 5. For small diameter cylinders, apply grease using the watchmakers screw driver.

4-2. Piston seal

After mounting the seal, apply grease to the inner and outer peripheries of the seal groove while rubbing it by finger as shown in Fig. 6.

4-3. Tube gasket

Mount the tube gasket on the cover.

After completion of installation, check the cylinder for smooth manual movement. Moreover, the procedure will be finished after checking a leakage from the seal.

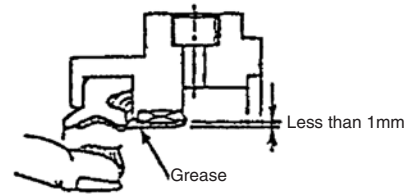

Fig. 5 Rod seal

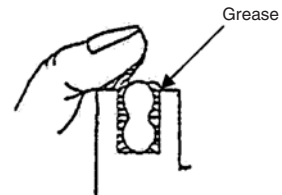

Fig. 6 Piston seal

5. Replacement Procedure of Shock Absorber

5-1. Loosen the hexagon socket head set screw (M3) at the piston rod by approximately one turn, and push down the lever. (See Fig. 7)

Tool: Hexagon wrench: Width across flats 1.5mm

Replacement Parts: Shock Absorber

Bore size (mm)	Kit no.
32	RB1007-X225
40-50	RB1407-X552

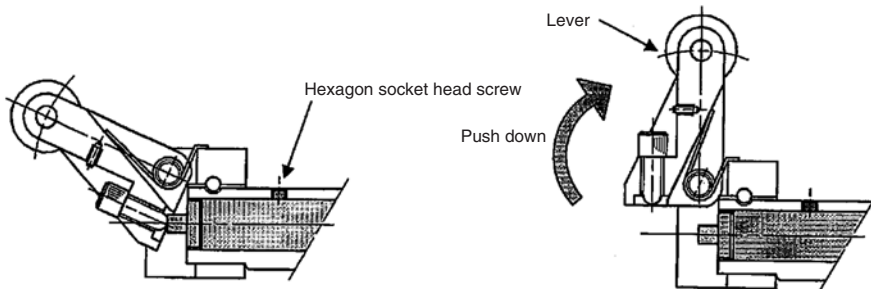

Fig. 7

5-2. While pushing down the lever, remove the shock absorber and replace it with a new shock absorber.

Tighten the hexagon socket set screw (M3 x 0.5) of the piston rod. Stop tightening around 1/4 turn after the set screw comes into contact with the shock absorber.

If it is tightened too much, it may cause damage to the hexagon socket set screw or a malfunction of the shock absorber.

Tightening torque: 0.29 N·m

Tool: Hexagon wrench: Width across flats 1.5mm

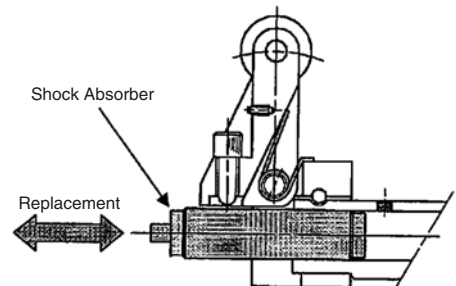

Fig. 8

1. Replacement Procedure of Seal

The piston seal, cylinder tube gasket, O-ring of the RSH/RS2H series can be replaced. The scraper of the RSH series can be replaced.

Contact SMC sales if it is necessary to replace parts other than those mentioned above.

⚠ Caution

When replacing seals, take care not to hurt your hand or finger on the corners of parts.

2. Disassembly/Reassembly

⚠ Caution

Disassemble and assemble the cylinder in a clean area. Perform on a clean cloth.

When disassembling the cylinder, loosen the hexagon socket head cap screws (ø20: 2pcs., ø32 to ø80: 4pcs.) with a hexagon wrench. Remove the rod cover and piston rod from the cylinder tube as Fig.1

When reassembling, apply locking adhesive on the hexagon socket head cap screws and tighten them.

- Hexagon socket head cap screw tightening torque
 - ø20: 3.0 N·m
 - ø32: 5.2 N·m
 - ø50: 12.5 N·m
 - ø63: 24.5 N·m
 - ø80: 42.0 N·m

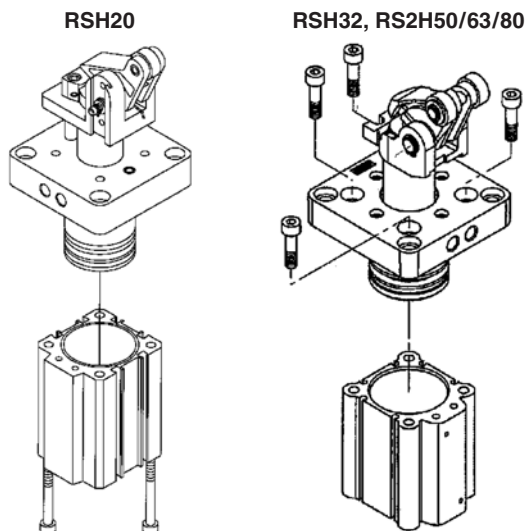

Fig. 1

3. Removal of Seal

3-1. Piston seal

Wipe off grease around piston seal first to make removal easier.

Hold piston seal with one hand and push it into groove so that piston seal can be lifted off and pulled out without using a watchmakers screw driver. (Fig. 2)

3-2. Tube gasket

Remove the tube gasket with the watchmakers screw driver or the like.

3-3. O-ring

Remove the tube gasket with the watchmakers screw driver or the like.

3-4. Scraper (Series RSH only)

Remove the scraper by inserting a watchmakers screw driver or the like. Take care not to damage the seal groove of the cover at this time.

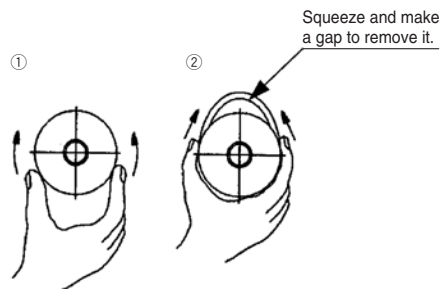

Fig. 2

Actuators

Modular F.R.L.
Pressure Control Equipment

Air Preparation
Equipment

Industrial Filters

Replacement
Procedure

Actuators

Modular F.R.L.
Pressure Control Equipment

Industrial Filters

4. Grease Application

Caution

Use our recommended grease.

Grease pack no.: GR-S-010 (10 g), GR-S-020 (20 g)

4-1. Piston seal (RSH, RS2H: No.37)

Lightly and evenly apply grease to the inner and outer circumferences for easier mounting on the piston.

4-2. Tube gasket (RSH: No.40, RS2H: No.39)

Lightly apply grease. This prevents its drop when assembling the cylinder.

4-3. O-ring (RSH: No.41, RS2H: No.40)

Lightly apply grease. This prevents its drop when assembling the cylinder.

4-4. Scraper (RSH: No.39)

Apply a little grease to the outer circumference of the new seal for replacement. This improves mounting and adhesion of the seal to the cover.

4-5. Cylinder component parts

Apply grease to each component parts of the cylinder in Figure 3.

RSH20/32

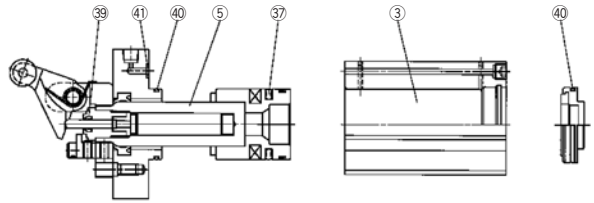

RS2H50/63/80

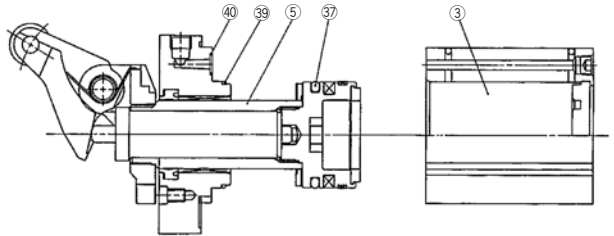

Fig. 3

5. Mounting of Seal

5-1. Piston seal

After mounting the seal, apply grease to the inner and outer peripheries of the seal groove while rubbing it by finger as shown in Fig. 4.

5-2. Tube gasket

Mounted to the cover. (For the RSH series, tube gasket is mounted to the bottom plate, too.)

5-3. O-ring

Apply O-ring to the cover.

5-4. Scraper

Mount the scraper, ensuring the correct orientation.

Apply grease to the inner circumference of packing using something, such as a precision screwdriver.

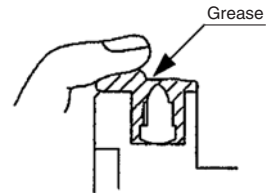

Fig. 4

Caution

Confirm that there is no problem with operation and air tightness after assembly.

6. Replacement Procedure of Shock Absorber

~Series RSH (Fig. 5)~

- 6-1. Loosen two hexagon socket head set screws of the stopper and the shock absorber set screw to remove the stopper from the lever holder.
- 6-2. Push down the lever 90 degrees and loosen the adjusting dial to remove it.
- 6-3. Pull out the shock absorber and replace it with a new shock absorber.
- 6-4. After tightening the adjusting dial, fix the stopper with hexagon socket head cap screws. Before fixing the stopper with hexagon socket head cap screws, apply adhesive to the screws.

- Hexagon socket head capscrew tightening torque: 1.5 N·m

- 6-5. Fix the shock absorber with a set screw.

- Set screw tightening torque: 1.5 N·m

~Series RS2H (Fig. 6)~

- 6-1. Loosen the set screw (M4) of the lever holder which fixes the shock absorber. Push down the lever 90 degrees to pull out the shock absorber.
- 6-2. Fix the shock absorber with a set screw.

- Set screw tightening torque: 1.5 N·m

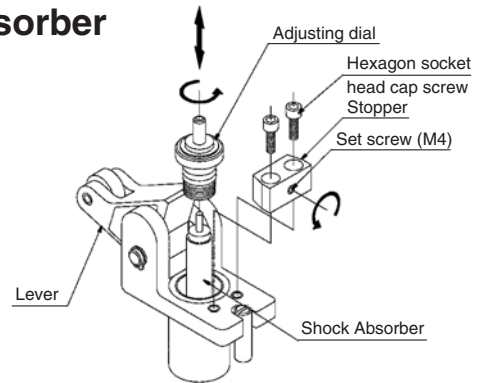

Fig. 5

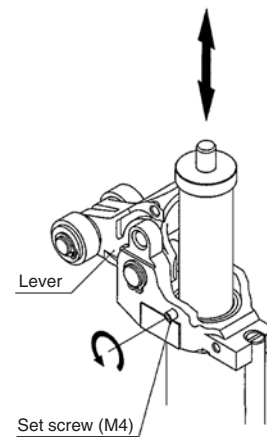

Fig. 6

⚠ Caution

After replacing the shock absorber, tighten the set screw firmly and apply grease to the shock absorber rod end surface (Fig.7).

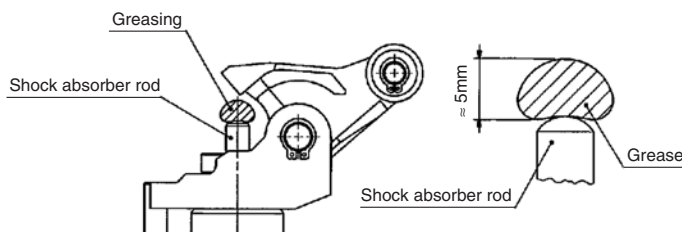

Fig. 7

Actuators

Modular F.R.L.
Pressure Control Equipment

Air Preparation
Equipment

Industrial Filters

Replacement
Procedure

Actuators

Modular F.R.L.
Pressure Control Equipment

Industrial Filters

Series MIW/MIS Replacement Procedure of Finger/Seal 1

1. Replacement Procedure of Finger

- 1-1. Remove the hexagon socket head cap screws.
- 1-2. Remove the cover.
- 1-3. Replace the finger.
 - a. Apply the specified grease to the finger, body, cover and T groove part of the finger.
 - b. Insert the piston in the T groove so that it will be hooked there.
- 1-4. Fix the cover and tighten the hexagon socket head cap screws.

Bore size	Hexagon socket head cap screw	Hexagon width across flats	Tightening torque (N·m)
8	M2 x 6	1.5	0.24
12	M2.5 x 6	2	0.36
20	M4 x 10	3	1.5
25	M5 x 14	4	3.0
32	M6 x 15	5	5.2

Note) For assembly, apply Henkel Japan Loctite No.243 or equivalent adhesive and tighten with the specified tightening torque. Please consult SMC if you feel replacement is difficult.

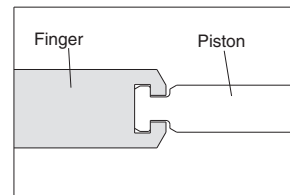
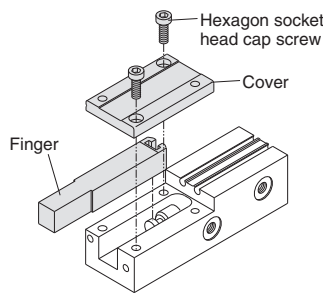
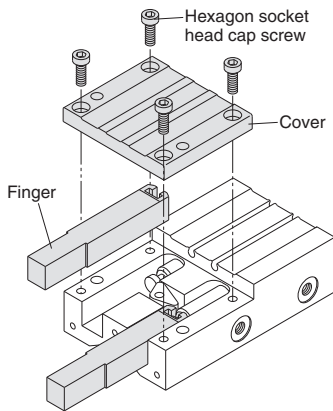

Finger and piston connection

2. Replacement Procedure of Seal

- 2-1. Remove the cover and the finger. (Refer to Replacement Procedure of Finger)
- 2-2. Loosen the hexagon socket set screws. (Refer to the table of hexagon socket set screw size).
 - * For MIS, hexagon socket set screw is not included except for the stroke adjusting type.
- 2-3. Remove the retaining ring with spring pliers to remove the cap.
 - * If there are any questions for ø8, please consult SMC.

Bore size	Hexagon socket set screw	Hexagon width across flats	Tightening torque (N·m)
8	M2 x 6	0.9	0.176
12	M2 x 6	0.9	0.176
20	M3 x 8	1.5	0.63
25	M4 x 8	2	1.5
32	M4 x 8	2	1.5

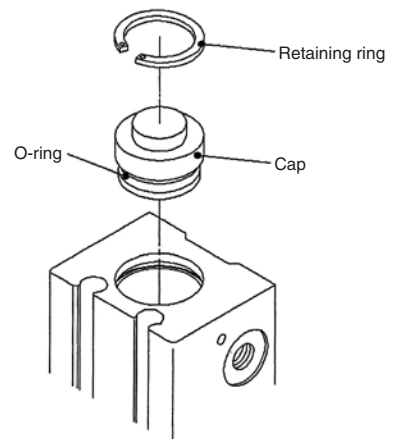
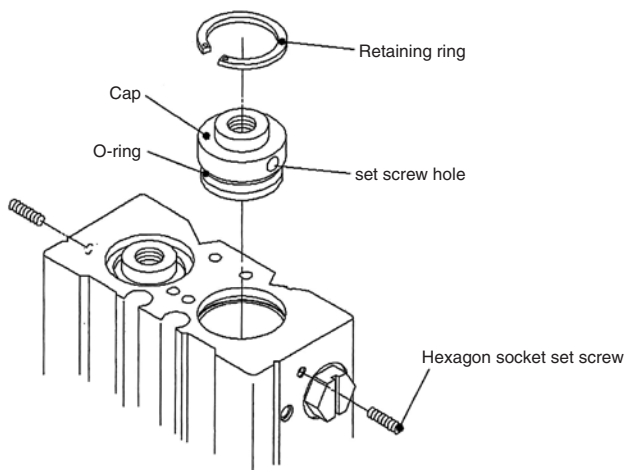

2-4. Take out the piston assembly and replace the seal, to which the specified grease is applied.

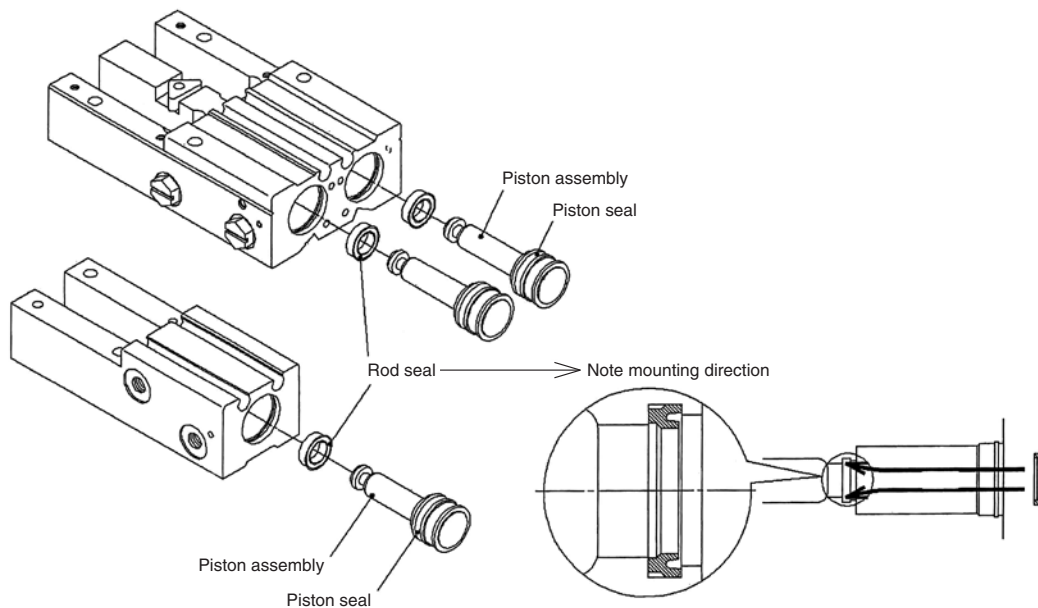

2-5. Apply the specified grease lightly to the sliding interface between the outer periphery and the body of the piston, and assemble them in the reversed order.

3. Scraper Option

Caution

1-1. Please observe the specified torque limits when mounting a scraper.

A tightening torque above the specified limits can cause a damage, while tightening torque below the specified limits can cause a dislocation or drop off.

Tightening torque

Model	Bolt (N·m)
MIW8	0.176
MIS8	
MIW12	0.36
MIS12	
MIW20	0.63
MIS20	
MIW25	0.63
MIS25	
MIW32	1.5
MIS32	

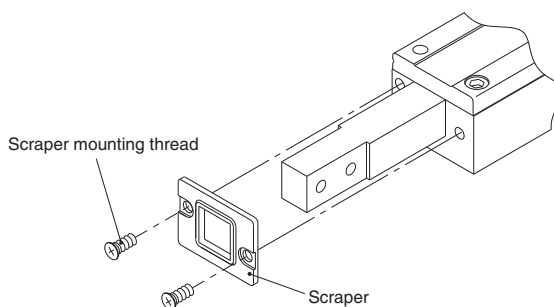
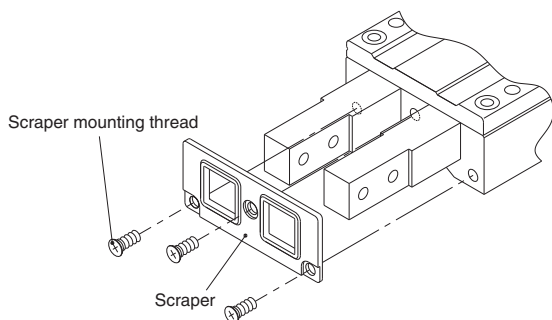

1. Exploded View

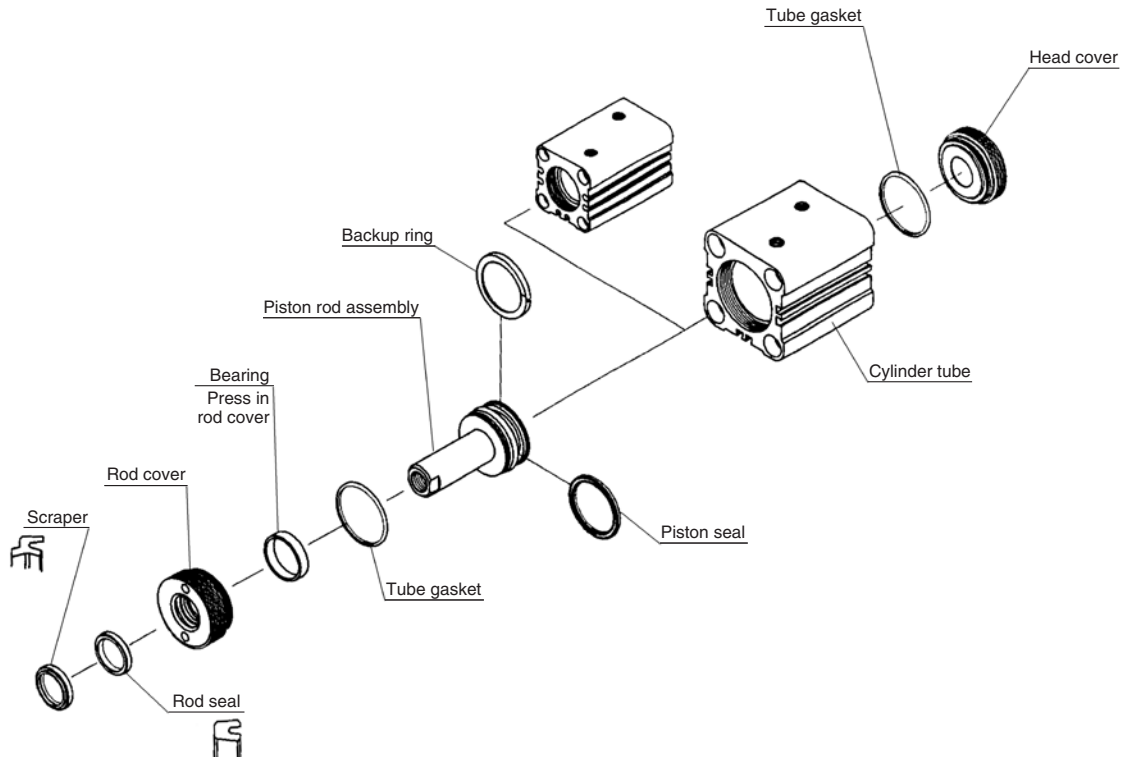

⚠ Caution

1. The piston rod assembly can not be disassembled. The bearing can not be removed because it is pressed into the rod cover.
2. Replace the seal with new one to disassemble and repair the cylinder.
3. If fuel oil such as gasoline and kerosene or solvent are used to wash parts touched to seal, wipe off or dry up them completely before assembling seal.
4. Apply hydraulic fluid (Oil used for the cylinder) or grease to the seal and the housing to be able to move smoothly before assembling.
5. Assemble the seal after confirming the sealing direction.
6. If a driver is used for mounting, round the point of the driver not to make a flaw on the seal and the housing.

7. For handling the seal, take care to avoid excessive extension and deformation.

Cover tightening torque

Bore size (mm)	Tightening torque (N·m)
20	23.5 ± 2.4
25	35.3 ± 3.5
32	68.6 ± 6.8
40	117.7 ± 11.7
50	215.7 ± 21.6
63	372.6 ± 37.3
80	804.1 ± 80.4
100	1470 ± 147

* Remount the cover with the tightening torques listed above.

1. Exploded View

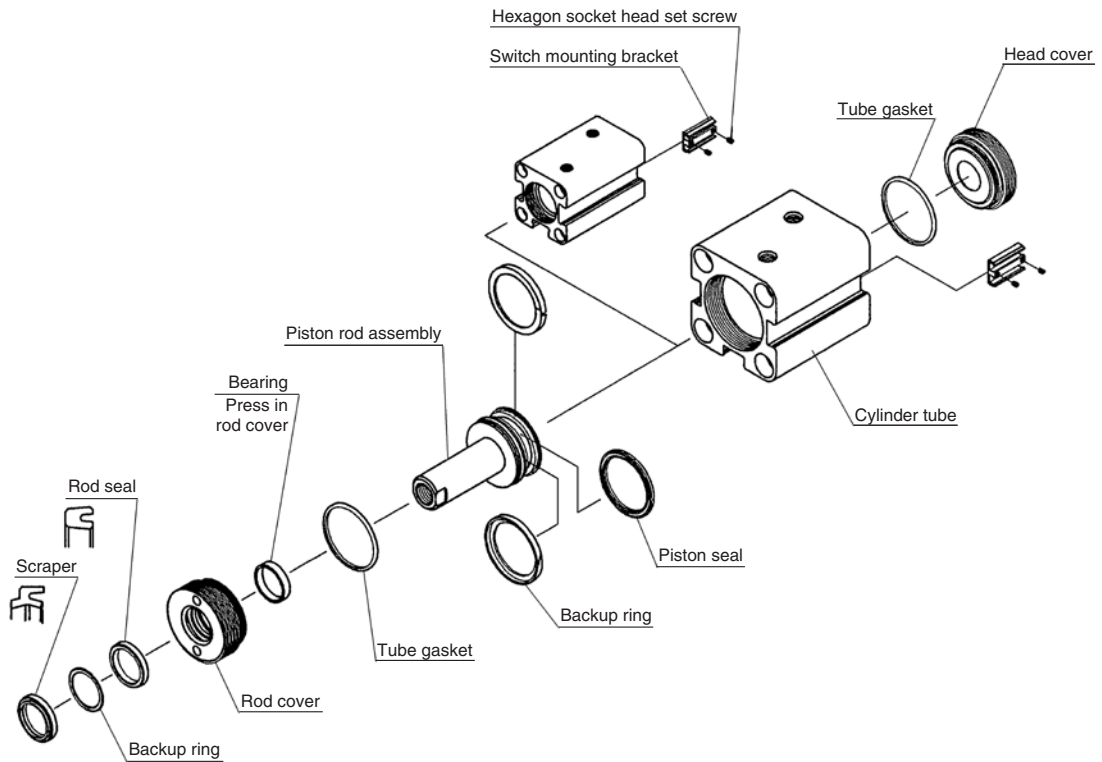

⚠ Caution

1. The piston rod assembly can not be disassembled. The bearing can not be removed because it is pressed into the rod cover.
2. Replace the seal with new one to disassemble and repair the cylinder.
3. If fuel oil such as gasoline and kerosene or solvent are used to wash parts touched to seal, wipe off or dry up them completely before assembling seal.
4. Apply hydraulic fluid (Oil used for the cylinder) or grease to the seal and the housing to be able to move smoothly before assembling.
5. Assemble the seal after confirming the sealing direction.
6. If a driver is used for mounting, round the point of the driver not to make a flaw on the seal and the housing.

7. For handling the seal, take care to avoid excessive extension and deformation.

Cover tightening torque

Bore size (mm)	Tightening torque (N·m)
20	23.5 ± 2.4
25	35.3 ± 3.5
32	68.6 ± 6.8
40	117.7 ± 11.7
50	215.7 ± 21.6
63	372.6 ± 37.3
80	804.1 ± 80.4
100	1470 ± 147

* Remount the cover with the tightening torques listed above.

Actuators

Modular F.R.L.
Pressure Control Equipment

Air Preparation
Equipment

Industrial Filters

Replacement
Procedure

Actuators

Modular F.R.L.
Pressure Control Equipment

Industrial Filters

Series CHN Replacement Procedure of Seal ①

1. Exploded View

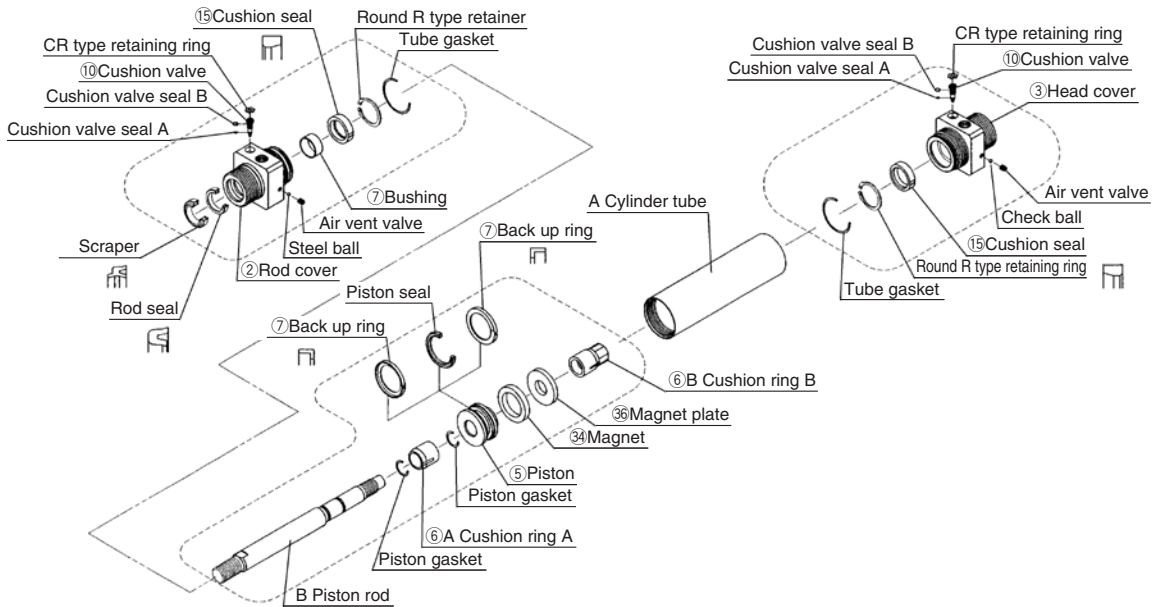

⚠ Caution

1. Rod cover and head cover are screw-in type.
2. Piston rod assembly cannot be disassembled. Bushing cannot be taken out as it is pressed into rod cover.
3. Replace seal at the time of cylinder disassembly and repair.
4. When fuel oil such as gasoline and kerosene or solvent is used to wash the parts that contact seal, thoroughly wipe or dry them off before placing.
5. Apply hydraulic oil (to be used for the cylinder) or grease to seal and housing for smooth sliding.
6. Verify sealing direction and them palece seal.
7. Blunt the tip of a driver not to flaw seal and housing.
8. Carefully handle the seal to avoid excessive elongation and deformation.
9. Please note that the positions of the rod and head covers might move from their original positions upon re-mounting.

1. Exploded View

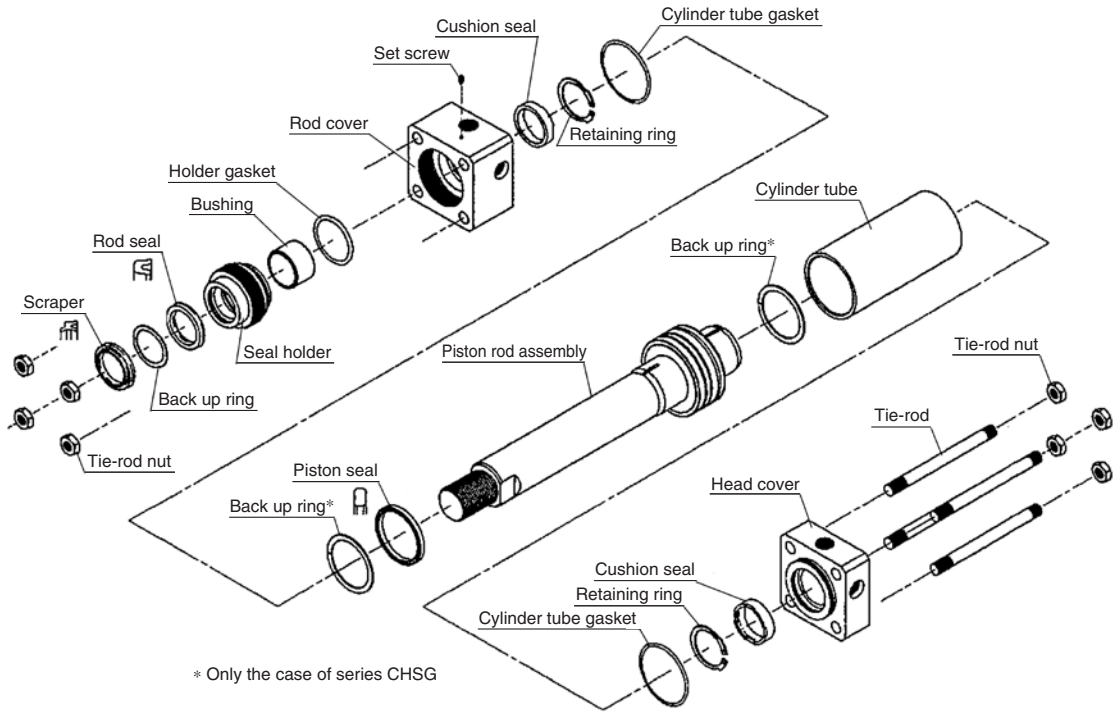

⚠ Caution

1. Piston rod assembly cannot be disassembled. Bushing cannot be taken out as it is pressed into seal holder.
2. Replace seal at the time of cylinder disassembly and repair.
3. When fuel oil such as gasoline and kerosene or solvent is used to wash the parts that contact seal, thoroughly wipe or dry them off before placing.
4. Apply hydraulic oil (to be used for the cylinder) or grease to seal and housing for smooth sliding.
5. Verify sealing direction and then place seal.
6. Blunt the tip of a driver not to flaw seal and housing when it is used for mounting.

7. Carefully handle the seal to avoid excessive elongation and deformation.

Tie-rod nut tightening torque

Bore size (mm)	Tightening torque (N·m)	
	CHSD	CHSG
32		10.8 ± 1.08
40	10.8 ± 1.08	24.5 ± 2.45
50	24.5 ± 2.45	24.5 ± 2.45
63	24.5 ± 2.45	42.2 ± 4.22
80	53.9 ± 5.39	137.3 ± 13.73
100	107.8 ± 10.78	137.3 ± 13.73

* Tighten tie-rod nuts diagonally and equally with torque shown in the table above.

1. Disassembling Drawing

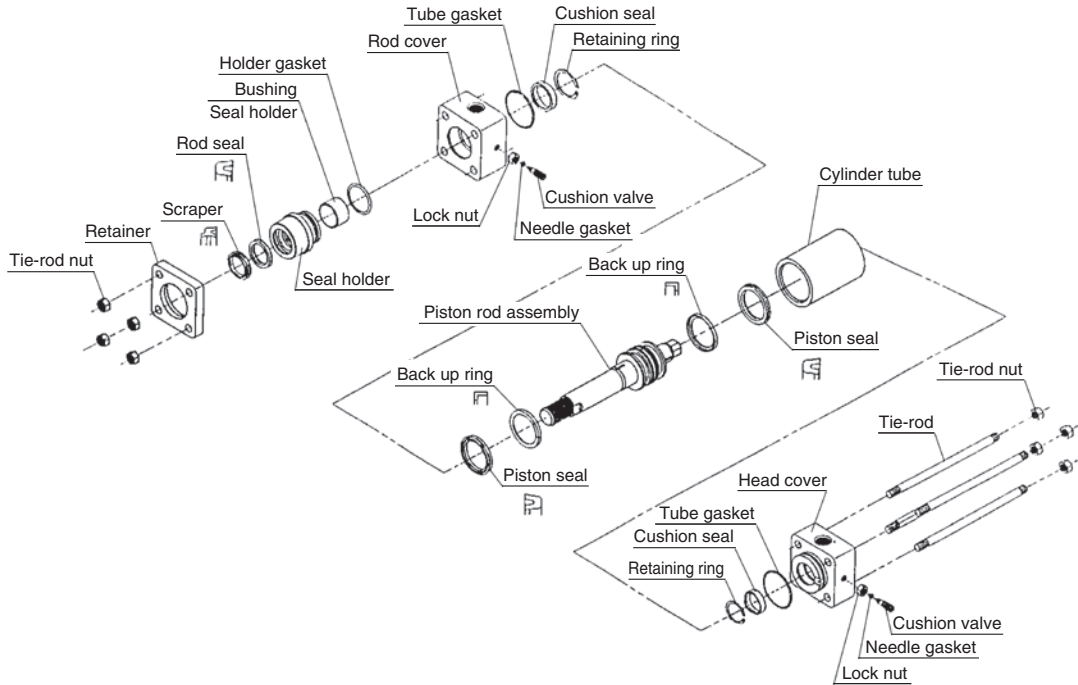

⚠ Caution

1. Piston rod assembly cannot be disassembled. Bearing cannot be taken out as it is pressed into rod cover.
2. Replace seal at the time of cylinder disassembly and repair.
3. When fuel oil such as gasoline and kerosine or solvent is used to wash the parts that contact seal, thoroughly wipe or dry them off before setting.
4. Apply hydraulic oil (to be used for the cylinder) or grease to seal and housing for smooth sliding.
5. Verify sealing direction and then set seal.
6. Blunt the tip of a driver not to scar seal and housing when it is used for mounting.

7. Carefully handle the seal to avoid excessive elongation and deformation.

Tie-rod nut tightening torque

Bore size (mm)	Tightening torque (N·m)		
	CH2E	CH2F	CH2G/H
32	11.8 ± 1.1	14.7 ± 1.4	24.5 ± 2.4
40	11.8 ± 1.1	19.6 ± 1.9	24.5 ± 2.4
50	14.7 ± 1.4	24.5 ± 2.4	24.5 ± 2.4
63	24.5 ± 2.4	39.2 ± 3.9	42.1 ± 4.2
80	44.1 ± 4.4	68.6 ± 6.8	107.8 ± 10.7
100	94 ± 4.9	73.5 ± 7.3	147.1 ± 14.7

* Tighten tie-rod nuts diagonally and equally with torque shown in the table above.

Modular Pressure Control Equipment F.R.L. Replacement Procedure

AF	Modular Type Air Filter	P.398
AFM	Modular Type Mist Separator	P.402
AFD	Modular Type Micro Mist Separator	P.402
AR	Modular Type Regulators	P.404
AL	Modular Type Lubricators	P.412
AW	Modular Type Filter Regulators	P.420
ARG	Modular Type Regulator with Built-in Pressure Gauge	P.431
AWG	Modular Type Filter Regulator with Built-in Pressure Gauge	P.437
AR425 to 925	Pilot Operated Regulator	P.444
AMR3000 to 6000	MR Unit (Regulator with Mist Separator)	P.448
ARM5	Compact Manifold Regulator	P.449
ARM10/11	Compact Manifold Regulator	P.453

Actuators

Modular F.R.L.
Pressure Control Equipment

Air Preparation
Equipment

Industrial Filters

Replacement
Procedure

Actuators

Modular F.R.L.
Pressure Control Equipment

Industrial Filters

AF10 to 40 Exploded View 1

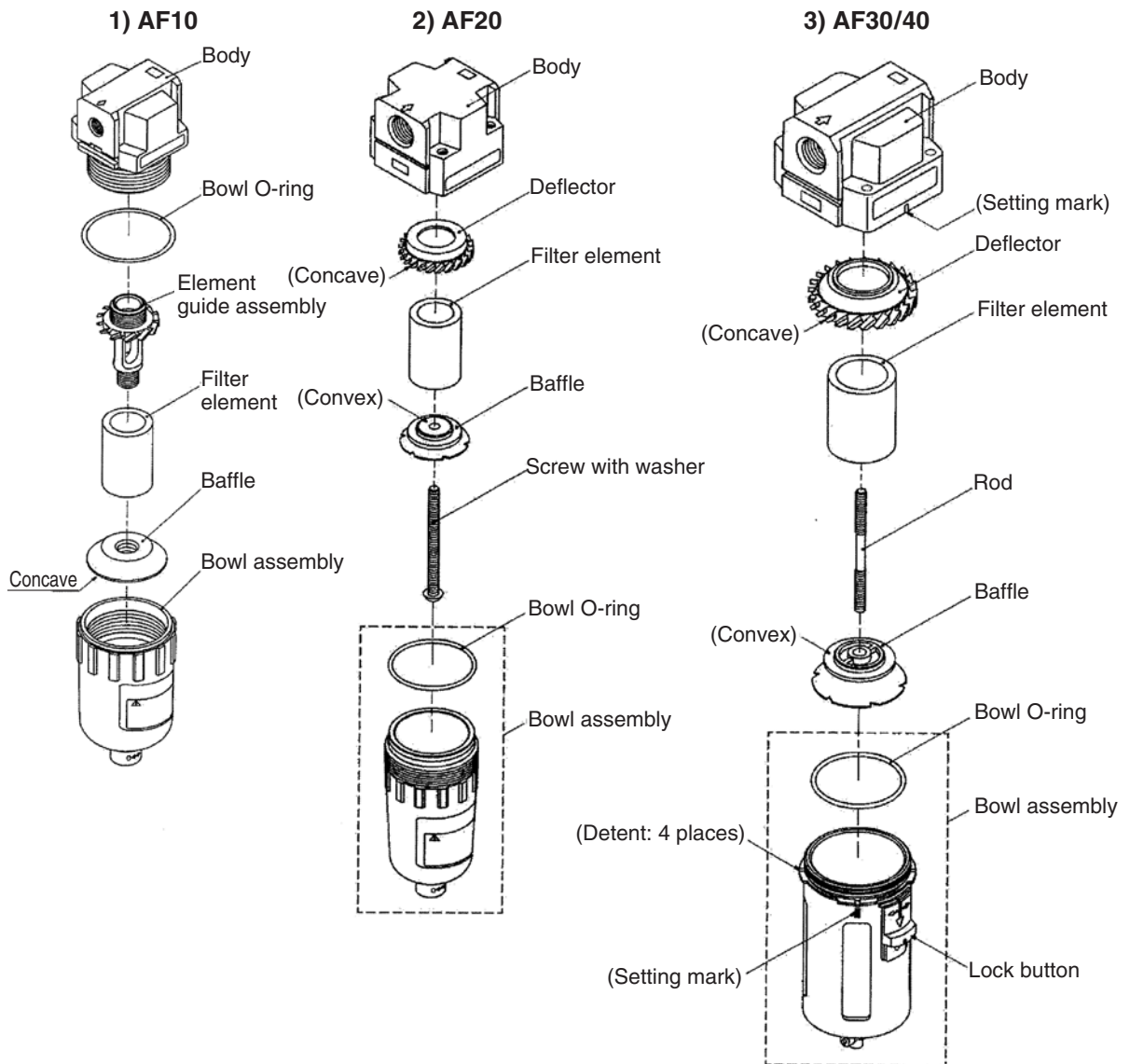

AF50/60 Exploded View 2

4) AF50/60

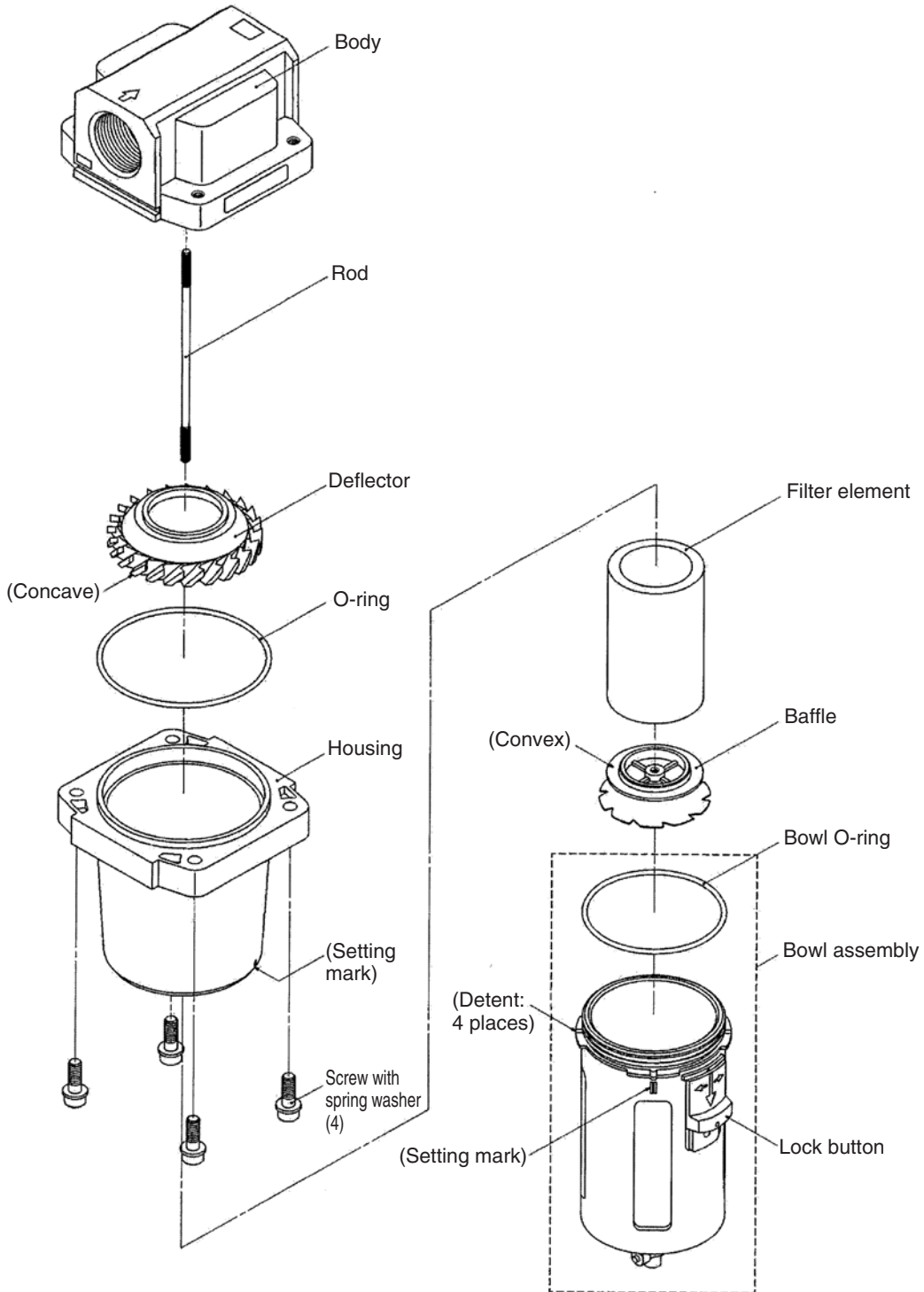

Actuators

Modular F.R.L.
Pressure Control Equipment

Air Preparation
Equipment

Industrial Filters

Replacement
Procedure

Actuators

Modular F.R.L.
Pressure Control Equipment

Industrial Filters

Series AF10 to 60 Replacement Procedure of Element 1

Warning

Before replacement, ensure that the regulator is not pressurized.
After replacement, ensure that specified function is satisfied and external leakage is not found before starting operation.

1. Bowl Assembly/Element

Applicable model	Process	Procedure	Tools	Check item
AF10	Disassembly	1) Remove the bowl assembly. Hold the bowl assembly by hand and rotate counterclockwise to remove the bowl assembly. If the bowl assembly is tightened too much to be removed, use hook spanner until it can be loosened by hand.	(Hook spanner Nominal: 25/28)	—
		2) Remove the baffle element Rotate the baffle by hand and counterclockwise to remove the baffle and element.	—	—
	Assembly	3) Mount the element. Mount the element to the element guide.	—	—
		4) Mount the baffle. Hold the baffle by hand to rotate it clockwise and mount the element. Baffle has mount direction. See disassembly drawing. For baffle tightening torque, see check item.	—	Tightening torque: 0.35 ± 0.05 N·m
		5) Mount the bowl assembly. Hold the bowl assembly by hand and rotate clockwise. Do not use tool for mounting because the bowl may be damaged. Refer to the "Check item" for referential tightening torque.	—	Referential tightening torque: 1.5 N·m
AF20	Disassembly	1) Remove the bowl assembly. Hold the bowl assembly by hand and rotate counterclockwise to remove the bowl assembly. If the bowl assembly is tightened too much to be removed, use hook spanner until it can be loosened by hand.	(Hook spanner Nominal: 34/38)	—
		2) Remove the cross recessed round head screw, baffle, element and deflector. Turn the cross recessed round head screw counterclockwise with a Phillips head screw driver to remove the baffle, element, and deflector.	Phillips head screw driver	—
	Assembly	3) Mount the deflector. Set the deflector into the body assembly while carefully checking the installation orientation (direction, in which the element enters the concave side).	—	Direction of deflector (For element concave side →Refer to the exploded view.)
		4) Mount the element. Insert the element into the recess of deflector.	—	—
		5) Mount the baffle. Insert the element while carefully checking the installation orientation (direction, in which the element enters the convex side).	—	Direction of baffle (For element convex side →Refer to the exploded view.)
		6) Tighten the cross recessed round head screw to secure the baffle, element, and deflector. Turn the cross recessed round head screw clockwise with a Phillips screwdriver to secure the baffle, element, and deflector. Refer to the "Check item" for tightening torque.	Phillips head screw driver	Tightening torque: 0.35 ± 0.05 N·m
		7) Mount the bowl assembly. Hold the bowl assembly by hand and rotate clockwise. Do not use tool for mounting because the bowl may be damaged. See check item for referential tightening torque.	—	Referential tightening torque: 2.2 N·m

Series AF10 to 60 Replacement Procedure of Element 2

Applicable model	Process	Procedure	Tools	Check item
AF30 AF40	Disassembly	1) Remove the bowl assembly. Push the bowl assembly lock button. Lifting the bowl assembly, rotate the assembly 45 degree (right or left) to pull out the assembly.	—	—
		2) Remove the baffle, element and deflector. Turn the baffle counterclockwise by hand to remove the baffle, element, and deflector.	—	—
	Assembly	3) Mount the deflector. Set the deflector into the body assembly while carefully checking the installation orientation (direction, in which the element enters the concave side).	—	Direction of deflector (For element concave side →Refer to the exploded view.)
		4) Mount the element. Insert the element into the recess of deflector.	—	—
		5) Mount the baffle. Insert the element while carefully checking the installation orientation (direction, in which the element enters the convex side).	—	Direction of baffle (For element convex side →Refer to the exploded view.)
		6) Tighten the baffle to secure the baffle, element, and deflector. Turn the baffle clockwise by hand until it is lightly connected to the element and deflector. After that, tighten the baffle further about 1/2 turn clockwise. Refer to the "Check item" for referential tightening torque.	—	Referential tightening torque: AF30: 0.5 N·m AF40: 0.9 N·m
		7) Mount the bowl assembly. Match the mating mark of the body and the bowl assembly to insert the assembly to the body. Rotate the assembly 45 degree (right or left) until the lock button is tossed up to mount the bowl assembly. Ensure the lock button is up.	—	Lock button is up.
AF50 AF60	Disassembly	1) Remove the bowl assembly Push the bowl assembly lock button. Lifting the bowl assembly, rotate the assembly 45 degree (right or left) to pull out the assembly.	—	—
		2) Remove the baffle element Rotate the baffle by hand and counterclockwise to remove the baffle and element.	—	—
	Assembly	3) Mount the element. Insert the element into the recess of deflector.	—	—
		4) Mount the baffle. Insert the element while carefully checking the installation orientation (direction, in which the element enters the convex side).	—	Direction of baffle (For element convex side →Refer to the exploded view.)
		5) Tighten the baffle to secure the baffle and element. Turn the baffle clockwise by hand until it is lightly connected to the element and deflector. After that, tighten the baffle further about 1/2 turn clockwise. Refer to the "Check item" for referential tightening torque.	—	Referential tightening torque: 1.8 N·m
		7) Mount the bowl assembly. Match the mating mark of the housing and the bowl assembly to insert the assembly to the housing. Rotate the assembly 45 degree (right or left) until the lock button is tossed up to mount the bowl assembly. Ensure the lock button is up.	—	Lock button is up.

Actuators

Modular F.R.L.
Pressure Control Equipment

Air Preparation
Equipment

Industrial Filters

Replacement
Procedure

Actuators

Modular F.R.L.
Pressure Control Equipment

Industrial Filters

AFM, AFD20 to 40 Disassembly Drawing 1

1) AFM, AFD20

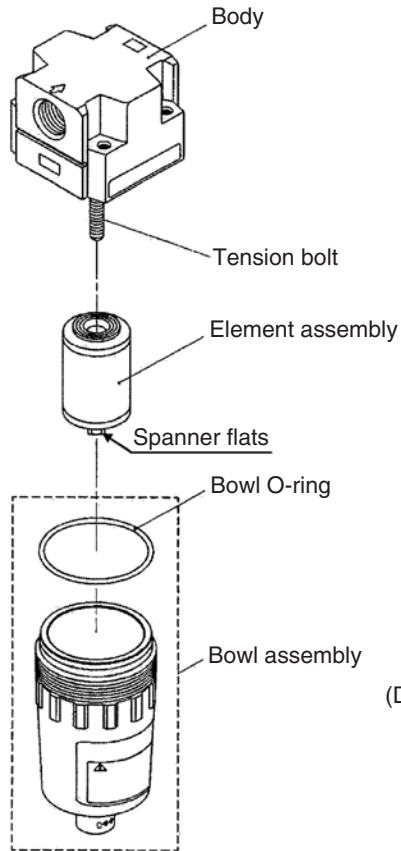

2) AFM, AFD30/40

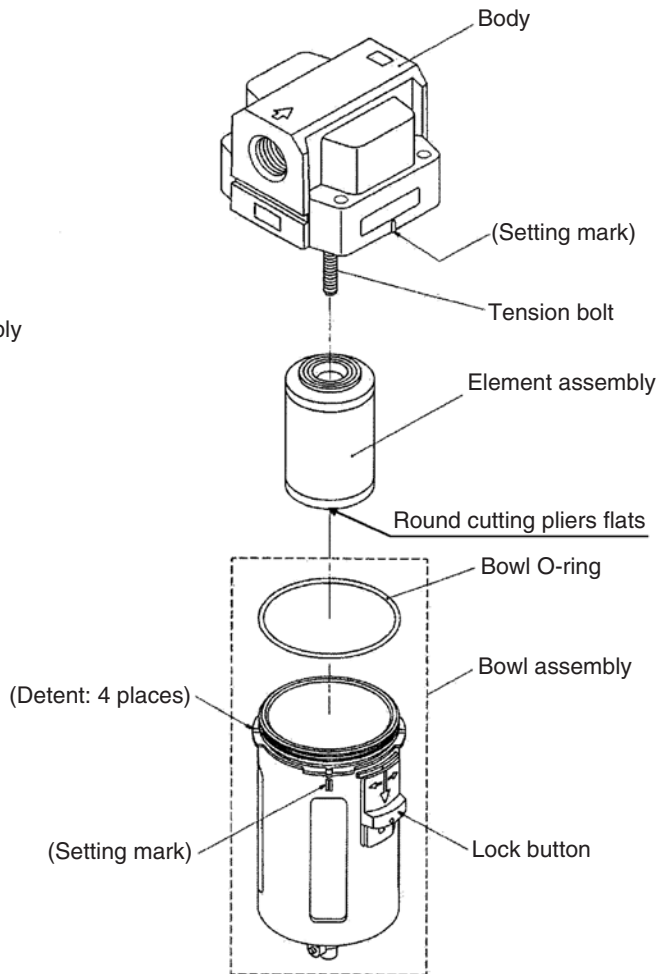

⚠ Warning

Before replacement, ensure that the regulator is not pressurized.
After replacement, ensure that specified function is satisfied and external leakage is not found before starting operation.

1. Bowl Assembly/Element

Applicable model	Process	Procedure	Tools	Check item
AFM20 AFD20	Disassembly	1) Remove the bowl assembly. Hold the bowl assembly by hand and rotate counterclockwise to remove the bowl assembly. If the bowl assembly is tightened too much to be removed, use hook spanner until it can be loosened by hand.	(Hook spanner Nominal: 34/38)	—
		2) Remove the element. Hold the element with a spanner to rotate it counterclockwise and remove the element.	Spanner Nominal: 7	—
	Assembly	3) Mount the element. Hold the element with a spanner to rotate it clockwise and mount the element. Refer to the "Check item" for the tightening torque.	Spanner Nominal: 7	Tightening torque: 0.35 ± 0.05 N·m
		4) Remove the bowl assembly. Hold the bowl assembly by hand and rotate counterclockwise to remove the bowl assembly. If the bowl assembly is tightened too much to be removed, use hook spanner until it can be loosened by hand.	—	Referential tightening torque: 2.2 N·m

Applicable model	Process	Procedure	Tools	Check item
AFM30 AFM40 AFD30 AFD40	Disassembly	1) Remove the bowl assembly. Push the bowl assembly lock button. Lifting the bowl assembly, rotate the assembly 45 degree (right or left) to pull out the assembly.	—	—
		2) Remove the element. Hold the element with a round cutting to rotate it counterclockwise and remove the element.	Round cutting	—
	Assembly	3) Mount the element. Hold the element with a round cutting to rotate it clockwise and mount the element. Refer to the "Check item" for the tightening torque.	Round cutting	Tightening torque: 0.35 ± 0.05 N·m
		4) Mount the bowl assembly. Match the mating mark of the body and the bowl assembly to insert the assembly to the body. Rotate the assembly 45 degree (right or left) until the lock button is tossed up to mount the bowl assembly. Ensure the lock button is up.	—	Lock button is up.

Actuators

Modular F.R.L.
Pressure Control EquipmentAir Preparation
Equipment

Industrial Filters

Replacement
Procedure

Actuators

Modular F.R.L.
Pressure Control Equipment

Industrial Filters

AR10 Exploded View 1

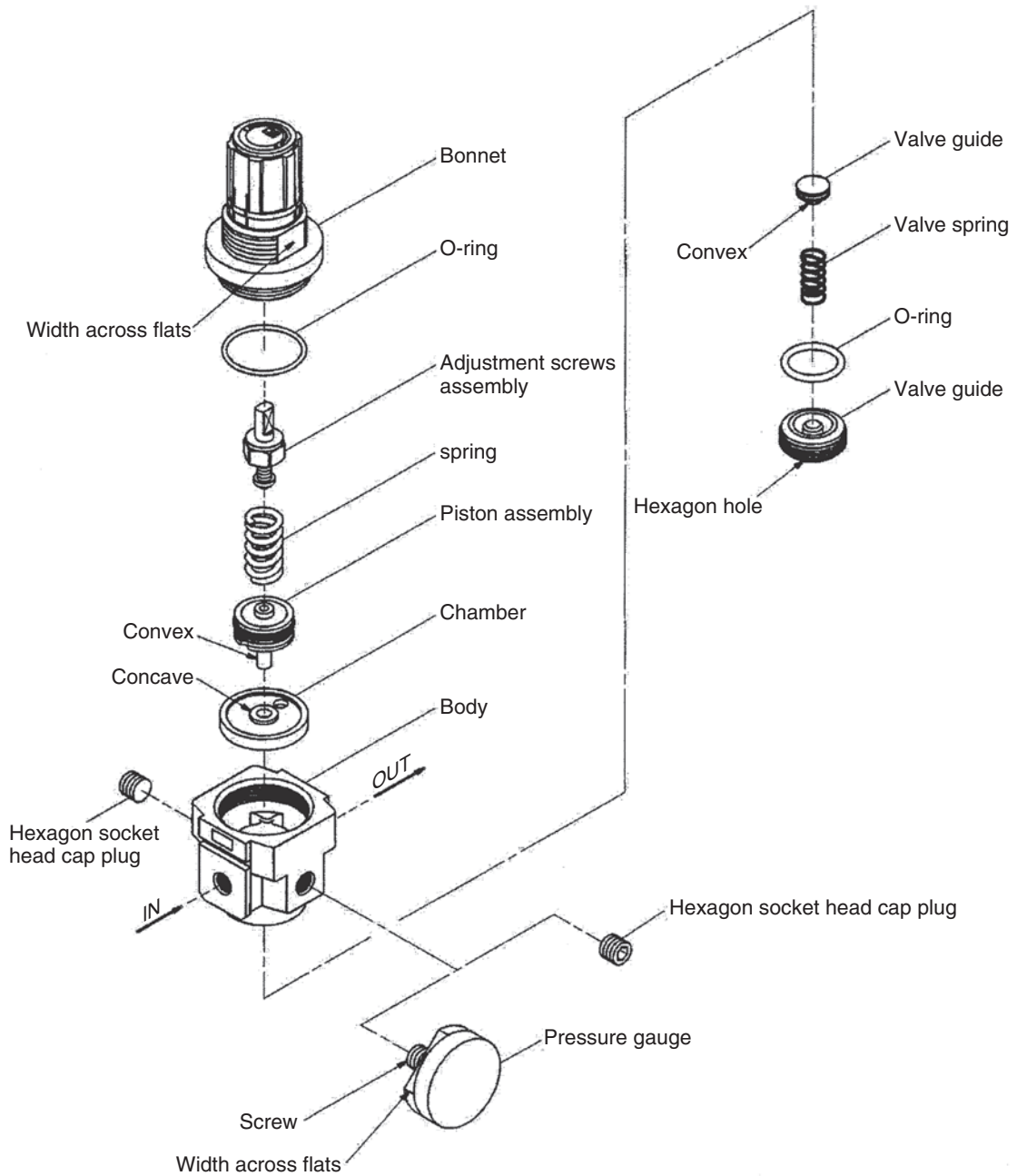

AR20(K)/25(K)/30(K)/40(K)/50(K)/60(K) Exploded View 2

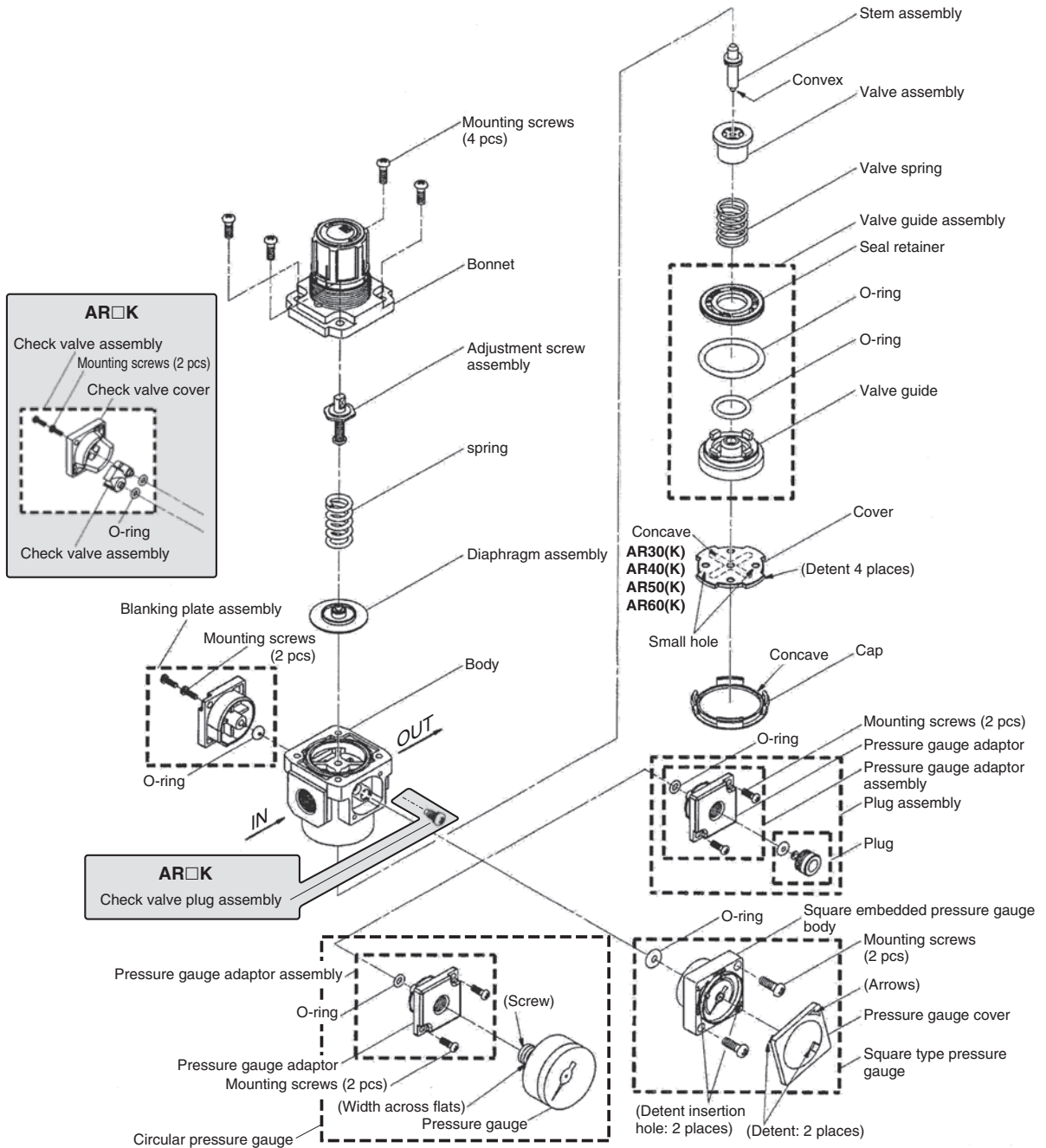

Note) It is possible to mount the square embedded pressure gauge or the pressure gauge adaptor assembly or the plug assembly instead of the blanking plate assembly.

AW20K to 60K
Note) The flow direction can be changed by taking off the check valve assembly, and replacing it with the square embedded gauge, pressure gauge adaptor assembly and plug assembly.

Actuators
 Modular F.R.L. Pressure Control Equipment
 Air Preparation Equipment
 Industrial Filters
 Replacement Procedure
 Actuators
 Modular F.R.L. Pressure Control Equipment
 Industrial Filters

Series AR□(K) Replacement Procedure of Diaphragm ①

⚠ Warning

Before replacement, ensure that the regulator is not pressurized.

Rotate the pressure adjusting handle to zero.

Replace referring to “Exploded View”

After replacement, ensure that specified function is satisfied and external leakage is not found before starting operation.

1. Diaphragm Assembly (Piston Assembly)

Applicable model	Process	Procedure	Tools	Check item										
AR10	Disassembly	1) Remove the bonnet assembly. Hold the bonnet with a spanner on the width across flat, and rotate counterclockwise to remove the bonnet assembly.	Spanner Nominal: 16											
		2) Remove the piston assembly from the bonnet. Pull out the piston assembly facing the handle downwards. Otherwise, pressure adjustment screw assembly or spring fall off.	—											
	Assembly	3) Mount the piston assembly to the bonnet assembly. Insert the piston assembly to the bonnet so that the piston assembly convex faces the body. If pressure adjustment screw or spring is not mounted on the bonnet, mount it before mounting the piston assembly.	—											
		4) Ensure the chamber is mounted on the body. If the chamber is removed during disassembly, mount the chamber ensuring the right direction of the chamber. Convex of the chamber shall face the bonnet side.	—	Presence of chamber. Mount if there is not a chamber Direction										
		5) Mount the bonnet assembly to the body. Hold the bonnet assembly with a spanner on the spanner flat, and rotate the body clockwise to settle. See check item for the tightening torque.	Spanner Nominal: 16	Tightening torque: 1.8 ± 0.3 N·m										
AR20(K) AR25(K) AR30(K) AR40(K) AR50(K) AR60(K)	Disassembly	1) Remove the bonnet. Rotate the set screw counterclockwise with a Phillips head screw driver to remove the bonnet from the body.	Phillips head screw driver	—										
		2) Remove parts in order of the pressure adjustment screw assembly, spring, and the diaphragm assembly. Please note that the diaphragm assembly will be attached to the bonnet if disassembled with the handle facing down.	—	—										
	Assembly	3) Mount parts to the body in order of the diaphragm assembly, spring, and pressure adjustment screw.	—	Mind the direction of the diaphragm assembly and the pressure adjustment screw assembly										
		4) Mount the bonnet to the body. Mount the convex IN side of the bonnet to the body, and tighten half way with 4 mounting screws with a Phillips head screw driver. Then, tighten the screws completely in a diagonal pattern with the indicated tightening torque.	Phillips head screw driver	Tightening torque <table border="1"> <tr> <td>AR20(K)</td> <td>2.15 ± 0.3 N·m</td> </tr> <tr> <td>AR25(K)</td> <td>2.35 ± 0.3 N·m</td> </tr> <tr> <td>AR30(K)</td> <td>2.35 ± 0.3 N·m</td> </tr> <tr> <td>AR40(K)</td> <td>3.5 ± 0.3 N·m</td> </tr> <tr> <td>AR50(K)</td> <td>4.5 ± 1 N·m</td> </tr> <tr> <td>AR60(K)</td> <td>4.5 ± 1 N·m</td> </tr> </table>	AR20(K)	2.15 ± 0.3 N·m	AR25(K)	2.35 ± 0.3 N·m	AR30(K)	2.35 ± 0.3 N·m	AR40(K)	3.5 ± 0.3 N·m	AR50(K)	4.5 ± 1 N·m
AR20(K)	2.15 ± 0.3 N·m													
AR25(K)	2.35 ± 0.3 N·m													
AR30(K)	2.35 ± 0.3 N·m													
AR40(K)	3.5 ± 0.3 N·m													
AR50(K)	4.5 ± 1 N·m													
AR60(K)	4.5 ± 1 N·m													

Series AR□(K) Replacement Procedure of Diaphragm 2

2. Valve Guide (Assembly), Valve Assembly

Applicable model	Process	Procedure	Tools	Check item
AR10	Disassembly	1) Remove the valve guide. Insert the hexagon wrench key to the valve guide hexagon socket, and rotate counterclockwise to remove it.	Hexagon wrench key Nominal: 6	—
		2) Remove the valve spring.	—	—
		3) Remove the valve.	—	—
	Assembly	4) Mount the valve. Set the valve so that the convex surface faces to the valve guide.	—	Concave surface (top) is the valve guide
		5) Mount the valve spring. Insert the valve so that the inner circumference of the valve spring fit in the convex surface of the valve.	—	—
		6) Ensure O-ring is mounted. Ensure valve guide seal O-ring is mounted. Mount O-ring if the ring is missing.	—	Presence of O-ring
		7) Mount the valve guide. Insert the hexagon wrench key to the valve guide hexagon socket, and rotate the spanner clockwise to tighten the guide. Refer to the "Check item" for the tightening torque.	Hexagon wrench key Nominal: 6	Tightening torque: 0.75 ± 0.15 N·m
AR20(K) AR25(K) AR30(K) AR40(K) AR50(K) AR60(K)	Disassembly	1) Remove the cap. Insert the watchmakers screw driver in the gap between the body and the cap and dig up the cap.	Watchmakers screw driver (-)	—
		2) Remove the cover. Insert the circular pliers into the 2 small holes of the cover, rotate 45 degrees to one side or the other and lift.	Circular pliers Nominal: 125	—
		3) Remove the valve guide assembly. Hold the valve guide with a needle nose pliers, and lift it.	Needle nose pliers	—
		4) Remove the valve spring.	—	—
		5) Remove the valve.	—	—
	Assembly	6) Mount the valve. Mate the stem convex and the valve center hole.	—	Positioning the stem and the valve (centering)
		7) Mount the valve spring. Insert the valve spring to the valve hole.	—	—
		8) Mount the valve guide assembly and the cover assembly to the body. Align the body groove and the cover clamp, push in the valve guide and cover assembly, insert the circular pliers into the 2 small holes of the cover and rotate 45 degrees to one side or the other to lock into place.	Circular pliers Nominal: 125	—
		9) Mount the cap. Mate the convex of the body cover and the concave of the cap, and push them in to settle. Ensure the end of the body and the cap are almost flat.	—	Orientation of the body and the cap. Body end and the cap are almost flat.

Actuators

Modular FRL
Pressure Control Equipment

Air Preparation
Equipment

Industrial Filters

Replacement
Procedure

Actuators

Modular FRL
Pressure Control Equipment

Industrial Filters

3. Bracket Assembly, Panel Mount

AR10/20(K)/25(K)/30(K)/40(K)
Bracket assembly; panel mount exploded View

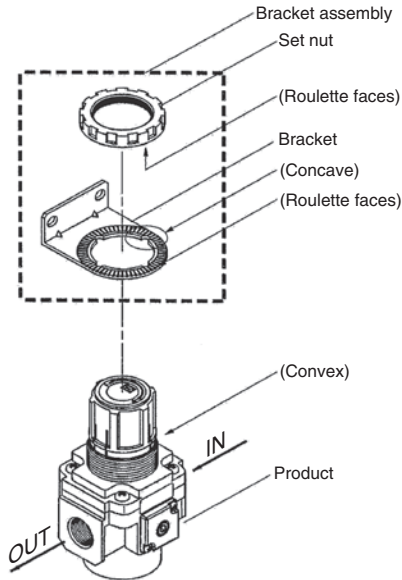

AR50(K)/60(K)
Bracket assembly; panel mount exploded View

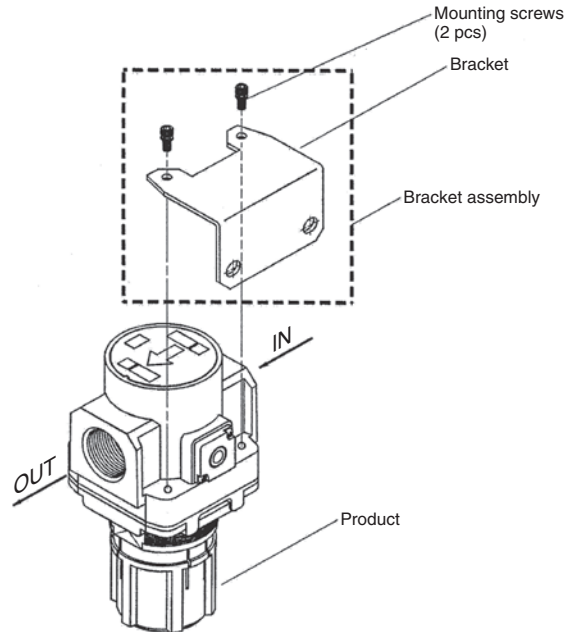

Note) The AR10 set nut and bracket do not have roulette faces.
The AR10 bracket and product do not have concave and convex interfaces.

Applicable model	Process	Procedure	Tools	Check item
AR10 AR20(K) AR25(K) AR30(K) AR40(K)	Assembly	1) Mount the parts to the bracket (panel). Mate the bracket (panel) concave and the bonnet convex to mount the bracket.	—	—
		2) Settle the bracket (panel) with set nut. Rotate the set nut clockwise with a hook spanner (spanner for AR10) to settle the parts to the bracket (panel). For the tightening torque, refer to the "Check item" on the right. When mounting the bracket for AR20(K)/25(K)/30(K)/40(K), ensure that the roulette faces of the set nut and the bracket are mated appropriately. When mounting with bracket, set nut tightened manually is adequate for general used. (AR20(K)/25(K)/30(K)/40(K))	AR10 Spanner Nominal: 24 AR20(K)/25(K)/30(K)/40(K) Hook spanner Nominal	Tightening torque AR10 0.8 ± 0.1 N·m Tightening torque AR20(K) 2.0 ± 0.2 N·m AR25(K) 2.5 ± 0.2 N·m AR30(K) 3.5 ± 0.3 N·m AR40(K) 4.0 ± 0.4 N·m
AR50(K) AR60(K)	Assembly (Bracket assembly)	1) Mount the bracket to the product. Fix them by tightening two mounting screws using a hexagon wrench key.	Hexagon wrench key Nominal: 5	Referential tightening torque: 2.6 N·m

4. Square Embedded Pressure Gauge

Applicable model	Process	Procedure	Tools	Check item
AR20(K) AR25(K) AR30(K) AR40(K) AR50(K) AR60(K)	Disassembly	1) Remove the pressure gauge cover. Rotate the pressure gauge cover 15 degrees to the arrow mark (counterclockwise) to pull it out.	—	—
		2) Remove the pressure gauge Rotate two mounting screws counterclockwise with Phillips head screw driver to remove the pressure gauge and two mounting screws.	Phillips head screw driver	—
	Assembly	3) Ensure O-ring is mounted to the pressure gauge. Mount O-ring to the pressure gauge if the ring fall off.	—	Presence of O-ring
		4) Mount the pressure gauge. Rotate two mounting screws clockwise with Phillips head screw driver to mounting screws temporary. Then settle them with tightening torque in check item.	Phillips head screw driver	Tightening torque: 0.3 ± 0.05 N·m
		5) Mount the pressure gauge cover. Insert the pressure gauge mating two detent of the pressure gauge and holes for them so that the arrow of the pressure gauge cover comes upper right. Rotate the pressure gauge cover 15 degree opposite to the arrow to mount the pressure gauge.	—	—

5. Circular Pressure Gauge

Applicable model	Process	Procedure	Tools	Check item	
AR10 AR20(K) AR25(K) AR30(K) AR40(K) AR50(K) AR60(K)	Disassembly	1) Remove the pressure gauge. Hold the pressure gauge with a spanner on the spanner flat. Then, rotate the gauge. Spanner for AR10 is a compact spanner.	Spanner Nominal	—	
			AR10 21		
	Assembly	2) Wrap the pressure gauge thread with the seal tape leaving 1.5 to 2 threads from the end. 3) Mount the pressure gauge. Hold the pressure gauge on the spanner flat with a spanner, and rotate it clockwise to mount the circular pressure gauge. Use compact spanner for Refer to the "Check item" for tightening torque of pressure gauge.	—	Spanner Nominal	Wrap seal tape leaving 1.5 to 2 threads
			AR20(K) 12	AR10 21	
			AR25(K) 12	AR25(K) 7 to 9 N·m	
			AR30(K) 14	AR30(K) 12 to 14 N·m	
			AR40(K) 14	AR40(K) 12 to 14 N·m	
			AR50(K) 14	AR50(K) 12 to 14 N·m	
			AR60(K) 14	AR60(K) 12 to 14 N·m	

Actuators

Modular F.R.L.
Pressure Control EquipmentAir Preparation
Equipment

Industrial Filters

Replacement
Procedure

Actuators

Modular F.R.L.
Pressure Control Equipment

Industrial Filters

Series AR□(K) Replacement Procedure of Diaphragm 5

6. Pressure Gauge Adapter, Plug Assembly

Applicable model	Process	Procedure	Tools	Check item
AR20(K) AR25(K) AR30(K) AR40(K) AR50(K) AR60(K)	Disassembly	1) Remove the plug. Insert the hexagon wrench key to hexagon socket of the plug. Rotate the plug counterclockwise to remove the plug.	Hexagon wrench key Nominal AR20(K) AR25(K) 4 AR30(K) AR40(K) AR50(K) 6 AR60(K)	—
		2) Remove the pressure gauge adapter. Rotate two mounting screws counterclockwise with Phillips head screw driver to remove the pressure gauge adapter and two mounting screws.	Phillips head screw driver	—
	Assembly	3) Ensure O-ring is mounted to the pressure gauge adapter. If not, mount O-ring.	—	—
		4) Mount pressure gauge adapter. Rotate two screws clockwise by Phillips head screw driver to fix pressure gauge adapter. Refer to the "Check item" for tightening torque of two screws.	Phillips head screw driver (Torque driver)	Tightening torque: 0.3 ± 0.05 N·m
		5) Mount plug assembly. Insert hexagon wrench key into hexagon socket on the plug and rotate clockwise to fix the plug. Refer to the "Check item" for tightening torque of two screws.	Hexagon spanner Nominal AR20(K) AR25(K) 4 AR30(K) AR40(K) AR50(K) 6 AR60(K)	Tightening torque: AR20(K) AR25(K) 0.6 ± 0.05 N·m AR30(K) AR40(K) AR50(K) 1.0 ± 0.1 N·m AR60(K)

7. Hexagon Plug

Applicable model	Process	Procedure	Tools	Check item
AR10	Disassembly	1) Remove the plug. Insert the hexagon wrench key to hexagon socket of the plug. Rotate the plug counterclockwise to remove the plug.	Hexagon wrench key Nominal: 4	—

8. Blanking Plate Assembly

Applicable model	Process	Procedure	Tools	Check item
AR20 AR25 AR30 AR40 AR50 AR60	Disassembly	1) Remove the blanking plate Rotate two mounting screws counterclockwise with Phillips head screw driver to remove the blanking plate and two mounting screws.	Phillips head screw driver	—
	Assembly	2) Ensure O-ring is mounted to the blanking plate. If not, mount O-ring.	—	—
		3) Mount blanking plate. Rotate two screws clockwise by Phillips head screw driver to fix blanking plate. Refer to the "Check item" for tightening torque of two screws.	Phillips head screw driver (Torque driver)	Tightening torque: 0.3 ± 0.05 N·m

Series AR□(K) Replacement Procedure of Diaphragm 6

9. Check Valve Assembly

Applicable model	Process	Procedure	Tools	Check item
AR20K AR25K AR30K AR40K AR50K AR60K	Disassembly	1) Remove check valve cover. Rotate two screws counterclockwise by Phillips head screw driver and remove the check valve cover and the screws.	Phillips head screw driver	—
		2) Remove the check valve assembly from body. The check valve can be removed by pulling it out by hand. At this time, confirm O-ring is mounted to body side properly so that it wouldn't come out from the body.	—	—
	Assembly	3) Confirm two O-rings is mounted to body side. If not, mount it to the body.	—	—
		4) Insert convexes on check valve into O-ring insert holes on body.	—	Orientation of the check valve body assembly
		5) Mount check valve cover. Rotate two screws clockwise by Phillips head screw driver to fix check valve cover. Refer to the "Check item" for tightening torque of two screws.	Phillips head screw driver (Torque driver)	Tightening torque: 0.3 ± 0.05 N·m

Actuators

Modular F.R.L.
Pressure Control Equipment

Air Preparation
Equipment

Industrial Filters

Replacement
Procedure

Actuators

Modular F.R.L.
Pressure Control Equipment

Industrial Filters

AL10 to 40 Exploded View 1

AL10

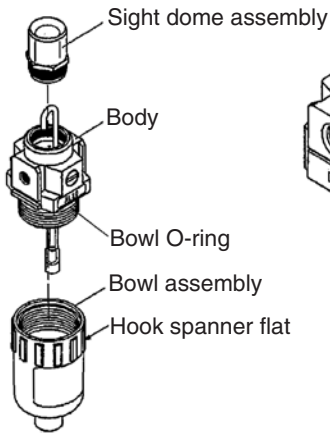

AL20

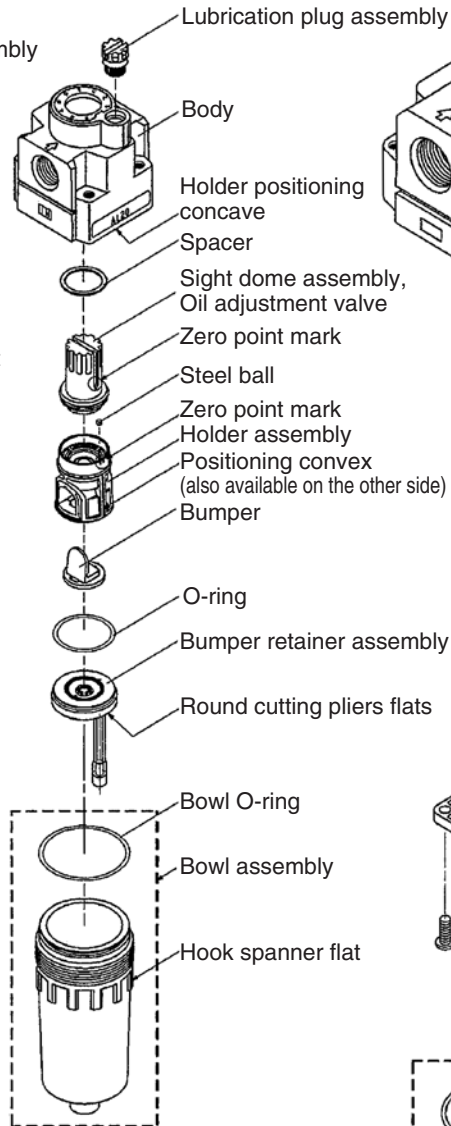

AL30/40

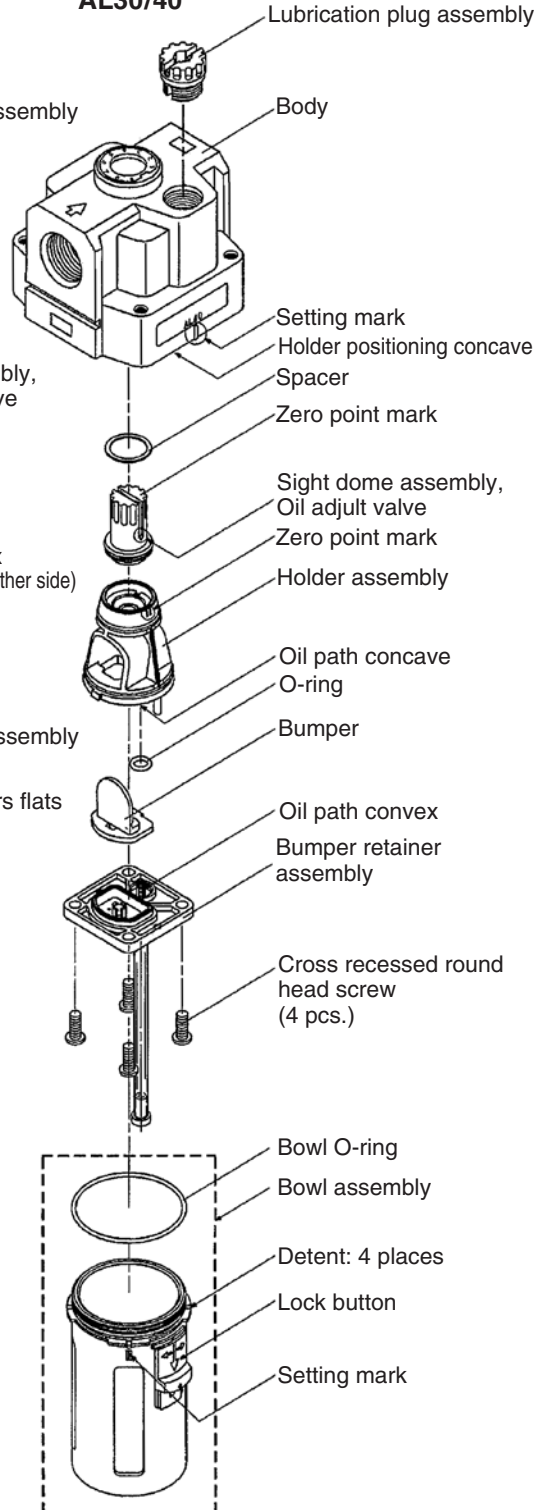

AL50/AL60 Exploded View 2

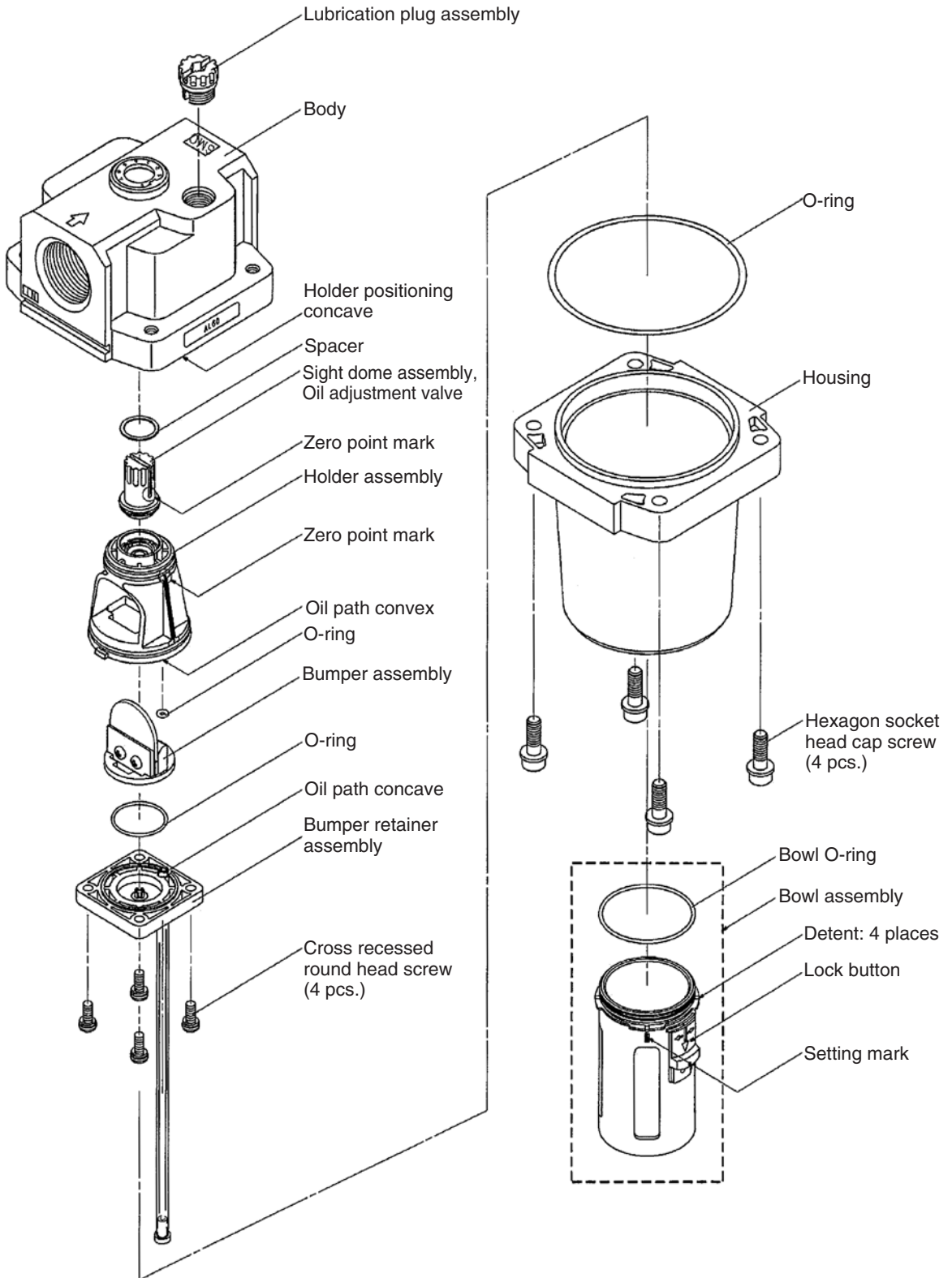

Actuators

Modular F.R.L.
Pressure Control Equipment

Air Preparation
Equipment

Industrial Filters

Replacement
Procedure

Actuators

Modular F.R.L.
Pressure Control Equipment

Industrial Filters

AL30 to 60 1000cm³ Tank Exploded View 3

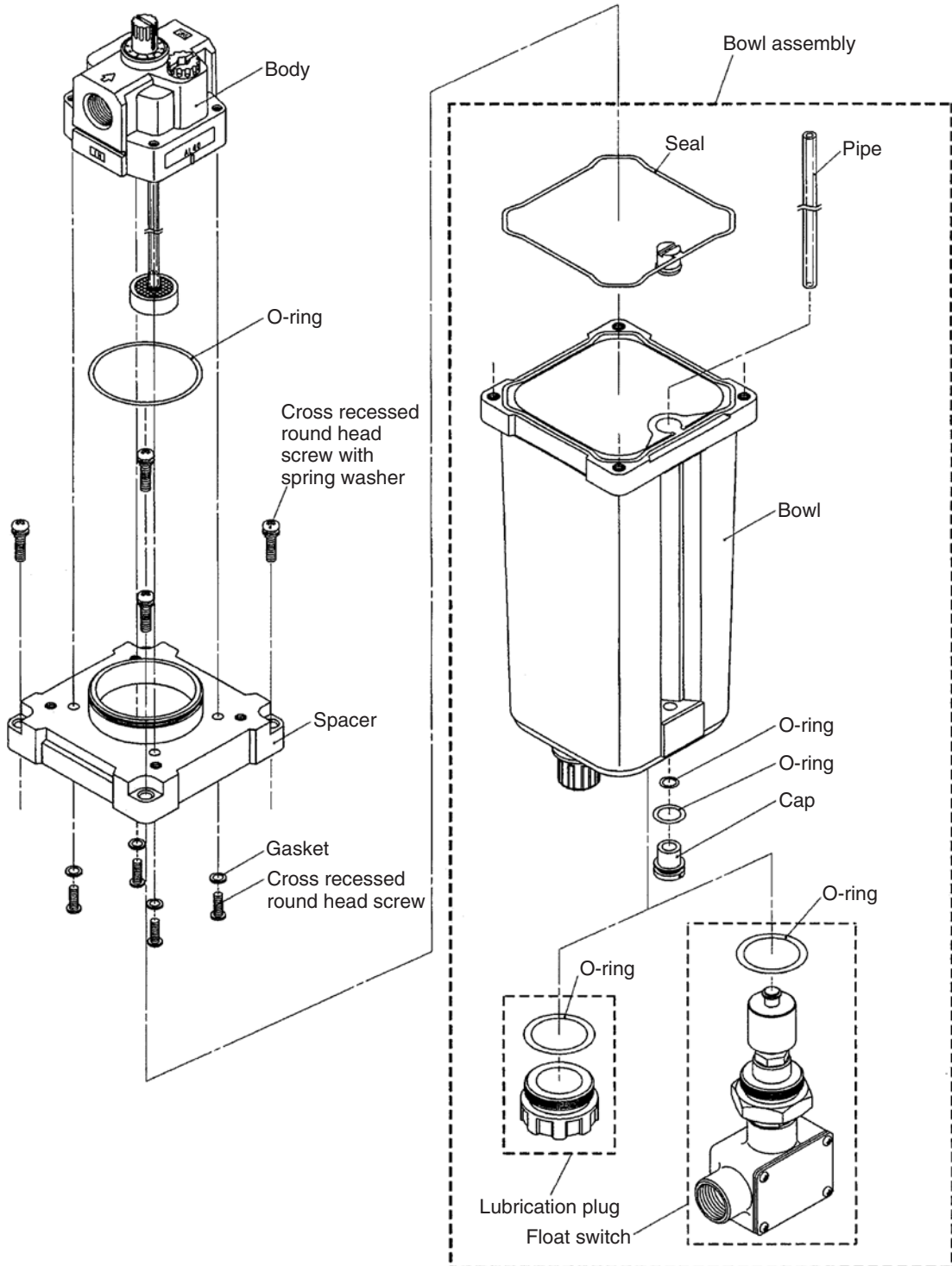

AL20 to 60 Bracket Assembly Exploded View 4

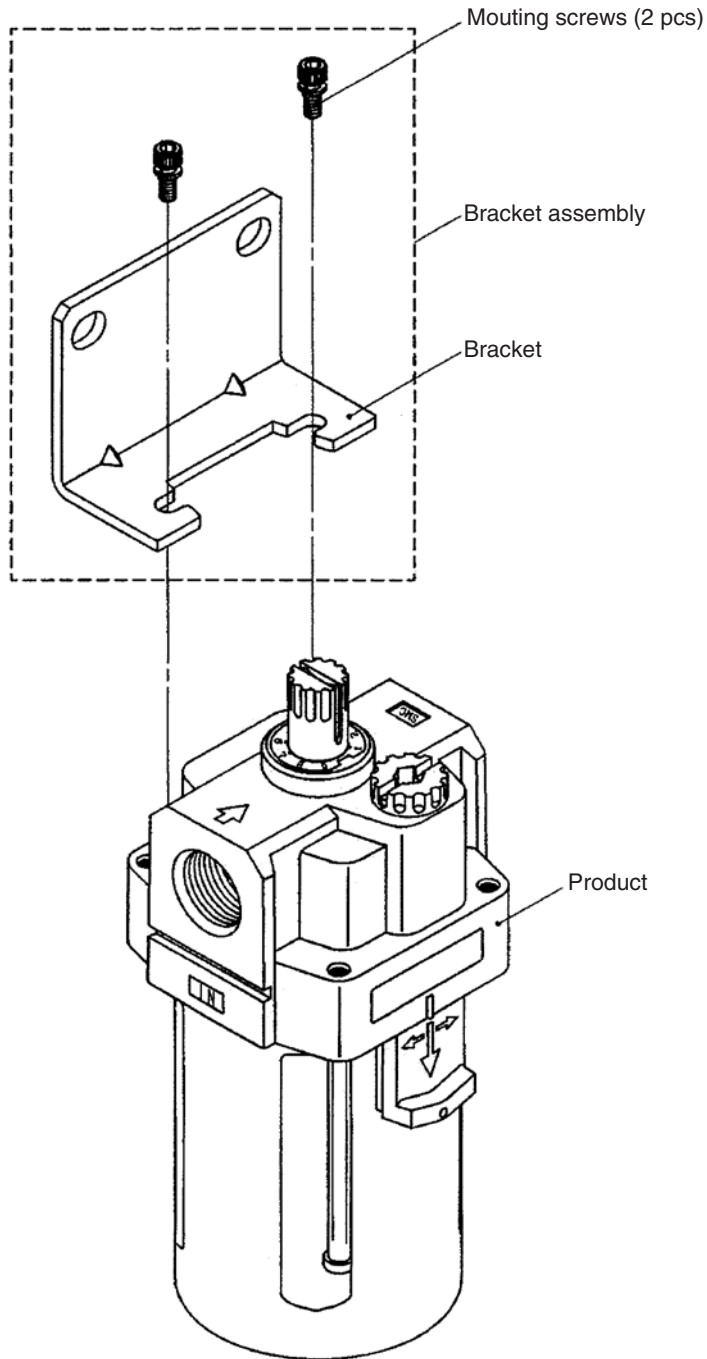

Actuators

Modular F.R.L.
Pressure Control Equipment

Air Preparation
Equipment

Industrial Filters

Replacement
Procedure

Actuators

Modular F.R.L.
Pressure Control Equipment

Industrial Filters

Series AL10 to 60 Replacement Procedure 1

Warning

Before replacement, ensure that the regulator is not pressurized.

After replacement, ensure that specified function is satisfied and external leakage is not found before starting operation.

1. Bowl Assembly, Sight Dome Assembly

Applicable model	Process	Procedure	Tools	Check item
AL10	Disassembly	1) Remove the bowl assembly. Hold the bowl assembly by hand and rotate counterclockwise to remove the bowl assembly. If the bowl assembly is tightened too much to be removed, use hook spanner until it can be loosened by hand.	(Hook spanner Nominal: 25/28)	—
		2) Remove the sight dome assembly. Rotate counterclockwise with spanner to remove the sight dome assembly.	Spanner Nominal: 14	—
	Assembly	3) Mount the bowl assembly. Hold the bowl assembly by hand and rotate clockwise. Do not use tool for mounting because the bowl may be damaged. Refer to the "Check item" for referential tightening torque.	—	Referential tightening torque: 1.5 N·m
		4) Mount the sight dome assembly. Rotate clockwise with spanner to mount the sight dome assembly. Tightening torque at this time is shown on "Check item".	Spanner Nominal: 14 (Torque wrench)	Tightening torque: 0.8 ± 0.2 N·m

Series AL10 to 60 Replacement Procedure 2

2. Bowl Assembly (Housing), Bumper Retainer Assembly, Bumper, Sight Dome Assembly,

Applicable model	Process	Procedure	Tools	Check item
AL20	Disassembly	1) Remove the bowl assembly. Hold the bowl assembly by hand and rotate counterclockwise to remove the bowl assembly. If the bowl assembly is tightened too much to be removed, use hook spanner until it can be loosened by hand.	(Hook spanner Nominal: 34/38)	—
		2) Close the oil adjustment valve (outer of the sight dome) fully. Rotate the oil adjustment valve clockwise by manual until feeling the end of rotation with light force.	—	—
		3) Remove bumper retainer assembly. Hold the bumper retainer assembly by round cutting pliers and rotate counterclockwise.	Round cutting pliers Nominal: 125 or 150	—
		4) Remove O-ring, bumper, holder assembly, steel ball, sight dome assembly and spacer. Push the sight dome assembly forward to the body by hand for disconnection. And the holder assembly and the sight dome assembly can be separated away by hand as well, but at the time the attention has to be paid not to lose the steel balls between them. Bumper can be pulled out by tweezers.	Tweezers	—
	Assembly	5) Insert the spacer to the sight dome assembly.	—	—
		6) Connect the sight dome assembly, the steel balls and the holder assembly. After inserting the steel balls into the path hole of oil on the holder assembly, put the sight dome assembly into the holder assembly by meeting zero point mark of both holder assembly and the sight dome.	—	Zero point mark on the holder assembly shall meet with zero point mark on the sight dome assembly.
		7) Insert the bumper into the holder assembly. For insertion, meet the setting concave (bumper) and convex (holder assembly)	—	Setting concave on the bumper shall meet with the setting convex on the holder assembly.
		8) Insert the assembly 5) to 7) mentioned above (sight dome + spacer + steel ball + holder assembly + damper) to the body. For insertion, meet the setting convex and concave on the body holder. Proper insertion makes the face of the holder and the body flat.	—	Setting concave on the body shall meet with the setting convex of the holder. The face of the holder and the body is made
		9) Mount the bumper retainer assembly. Hold the bumper retainer assembly by round cutting pliers and rotate clockwise. tightening torque at this time is shown on "Check item".	Round cutting pliers Nominal: 125 or 150	Tightening torque: 1.4 ± 0.1 N·m
		10) Mount the bowl assembly. Hold the bowl assembly by hand and rotate clockwise. Do not use tool for mounting because the bowl may be damaged. Refer to the "Check item" for referential tightening torque.	—	Referential tightening torque: 2.2 N·m
AL30 AL40	Disassembly	1) Remove the bowl assembly. Push the lock button on the bowl assembly down and rotate clockwise or counterclockwise by 45 ° with the bowl assembly brought upward. After the rotation, the bowl assembly can be pulled out.	—	—
		2) Close the oil adjustment valve (outer of the sight dome) fully. Rotate the oil adjustment valve clockwise by manual until feeling the end of rotation with light force.	—	—
		3) Remove the bumper retainer assembly. Loosen and remove four cross recessed round head screws by phillips head screw driver to remove the bumper retainer assembly. At this time, the attention has to be paid not to lose O-ring between the bumper retainer assembly and the holder assembly.	Phillips head screw driver	—
		4) Remove bumper, holder assembly, sight dome assembly and spacer. Push the sight dome assembly forward to the body by hand for disconnection. And the holder assembly and the sight dome assembly can be separated away by hand as well. Bumper can be pulled out by tweezers.	Tweezers	—
	Assembly	5) Insert the spacer into the assembly.	—	—
		6) Connect the sight dome assembly with the holder assembly. Put the sight dome assembly into the holder assembly by meeting zero point mark of both holder assembly and the sight dome assembly.	—	Zero point mark on the holder assembly shall meet with zero point mark on the sight dome assembly.

Actuators

Modular F.R.L.
Pressure Control EquipmentAir Preparation
Equipment

Industrial Filters

Replacement
Procedure

Actuators

Modular F.R.L.
Pressure Control Equipment

Industrial Filters

Series AL10 to 60 Replacement Procedure 3

Applicable model	Process	Procedure	Tools	Check item
AL30 AL40	Assembly	7) Insert the bumper into the holder assembly. For insertion, the shape of the bumper is matched to the shape of the convex part of the holder assembly.	—	Setting the shape of the bumper shall meet with the setting convex of the holder assembly.
		8) Insert the assembly 5) to 7) mentioned above (sight dome + spacer + holder assembly + bumper) to the body. For insertion, meet the setting convex and concave on the body holder. Proper insertion makes the face of the holder and the body flat.	—	Setting concave on the body shall meet with the setting convex of the holder. The face of the holder and the body is made.
		9) Mount the bumper retainer assembly. Place the bumper retainer assembly so that the oil path convex (bumper holder assembly) and concave (holder) could meet, and then fix it by four cross recessed round head screw by Phillips head screw driver. Tightening torque at this time is shown on "Check item". And the screw which is tightened next after first tightened screw shall be what is located at cross corner of first one.	Phillips head screw driver	Tightening torque AL30: 0.4 ± 0.1 N·m AL40: 0.7 ± 0.2 N·m
		10) Mount the bowl assembly. Insert the bowl assembly into the body by using individual setting mark and rotate clock or counterclockwise by 45° (until the lock button is released). If the release of the lock button is confirmed, mount of the bowl assembly is completed.	—	Lock button us up.
AL50 AL60	Disassembly	1) Remove the housing including the bowl assembly. Loosen four hexagon socket head cap screw by hexagon wrench to remove the housing (including the bowl assembly) and O-ring.	Hexagon wrench Nominal: 5	—
		2) Close the oil adjustment valve (outer of the sight dome) fully. Rotate the oil adjustment valve clockwise by manual until feeling the end of rotation with light force.	—	—
		3) Remove the damper retainer assembly. Loosen and remove four cross recessed round head screws by Phillips head screw driver to remove the bumper retainer assembly.	Phillips head screw driver	—
		4) Remove O-ring, bumper assembly, holder assembly, sight dome assembly and spacer. Push the sight dome assembly forward to the body by hand for disconnection. And the holder assembly and the sight dome assembly can be separated away by hand as well.	—	—
	Assembly	5) Insert the spacer into the assembly.	—	—
		6) Connect the sight dome assembly with the holder assembly. Put the sight dome assembly into the holder assembly by meeting zero point mark of both holder assembly and the sight dome assembly.	—	Zero point mark on the holder assembly shall meet with zero point mark on the sight dome assembly.
		7) Insert the bumper into the holder assembly. For insertion, the setting hole of the bumper assembly is matched to the convex part of the holder assembly.	—	Setting the setting hole of the bumper assembly shall meet with the convex of the holder assembly.
		8) Insert the assemblies 5) to 7) mentioned above (sight dome + spacer + holder assembly + bumper assembly) to the body. For insertion, meet the setting convex and concave on the body holder. Proper insertion makes the face of the holder and the body flat.	—	Setting concave on the body shall meet with the Setting convex of the holder. The face of the holder and the body is made flat.
		9) Install O-ring to the holder assembly.	—	—
		10) Mount the bumper retainer assembly. Place the bumper retainer assembly so that the oil path convex (bumper holder assembly) and concave (holder) could meet, and then fix it by four cross recessed round head screw by Phillips head screw driver. Tightening torque at this time is shown on "Check item". And the screw which is tightened next after first tightened screw shall be what is located at cross corner of first one.	Phillips head screw driver	Tightening torque AL50: 1.4 ± 0.1 N·m AL60: 1.4 ± 0.1 N·m
		11) Install O-ring to the body.	—	—
		12) Mount the housing including the bowl assembly. Place the housing including the bowl assembly on the body at the position with configuration match by checking the appearance of them and fix it by four hexagon socket head cap screw by hexagon wrench. Tightening torque at this time is shown on "Check item". And the screw which is tightened next after first tightened screw shall be what is located at cross corner of first one.	Hexagon wrench Nominal: 5 (Torque wrench)	Tightening torque AL50: 4.5 ± 1 N·m AL60: 4.5 ± 1 N·m

3. Lubrication Plug Assembly

Applicable model	Process	Procedure	Tools	Check item
AL20 AL30 AL40 AL50 AL60	Disassembly	1) Remove the lubrication plug assembly. Insert flat blade screw driver into the groove on the top of lubrication plug and rotate counterclockwise to remove the lubrication plug assembly from the body.	Flat blade screw driver	—
	Assembly	2) Mount the lubrication plug assembly. Insert flat blade screw driver into the groove on the top of lubrication plug and rotate clockwise to fix the lubrication plug assembly to the body. Tightening torque at this time is shown on "Check item".	Flat blade screw driver (Torque driver)	Tightening torque AL20: 0.3 ± 0.05 N·m AL30: 0.4 ± 0.05 N·m AL40 to 60: 0.55 ± 0.05 N·m

Actuators

Modular F.R.L.
Pressure Control Equipment

Air Preparation
Equipment

Industrial Filters

Replacement
Procedure

Actuators

Modular F.R.L.
Pressure Control Equipment

Industrial Filters

AW10 Exploded View 1

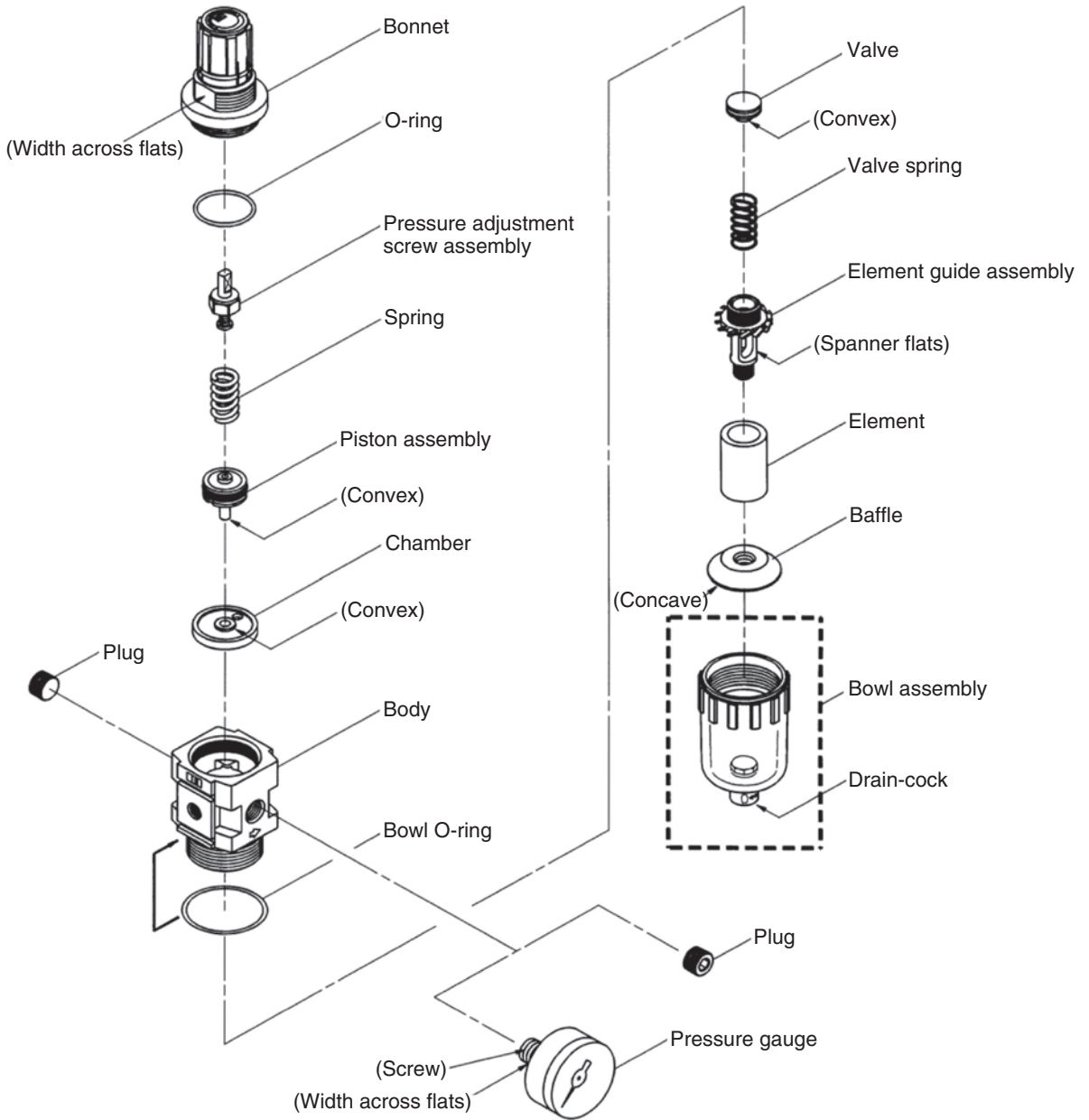

AW20(K) Exploded View 2

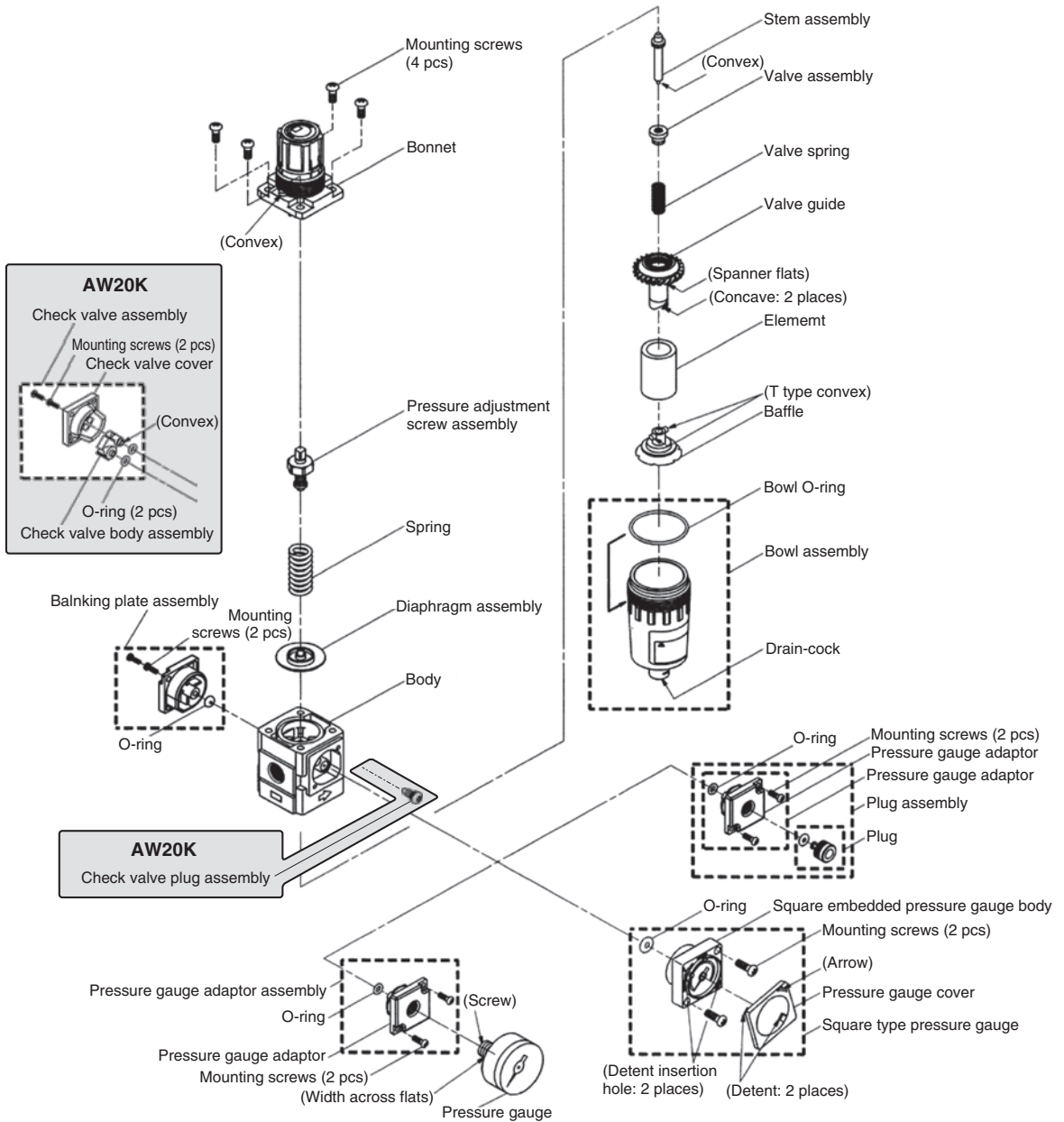

Note.) It is possible to mount square embedded pressure gauge or pressure gauge adaptor assembly or plug assembly instead of blanking plate assembly.

AW20K
 Note) The flow direction can be changed by taking off the check valve assembly, and replacing it with the square embedded gauge, pressure gauge adaptor assembly and plug assembly.

Actuators

Modular F.R.L.
 Pressure Control Equipment

Air Preparation
 Equipment

Industrial Filters

Replacement
 Procedure

Actuators

Modular F.R.L.
 Pressure Control Equipment

Industrial Filters

AW30(K)/40(K) Exploded View 3

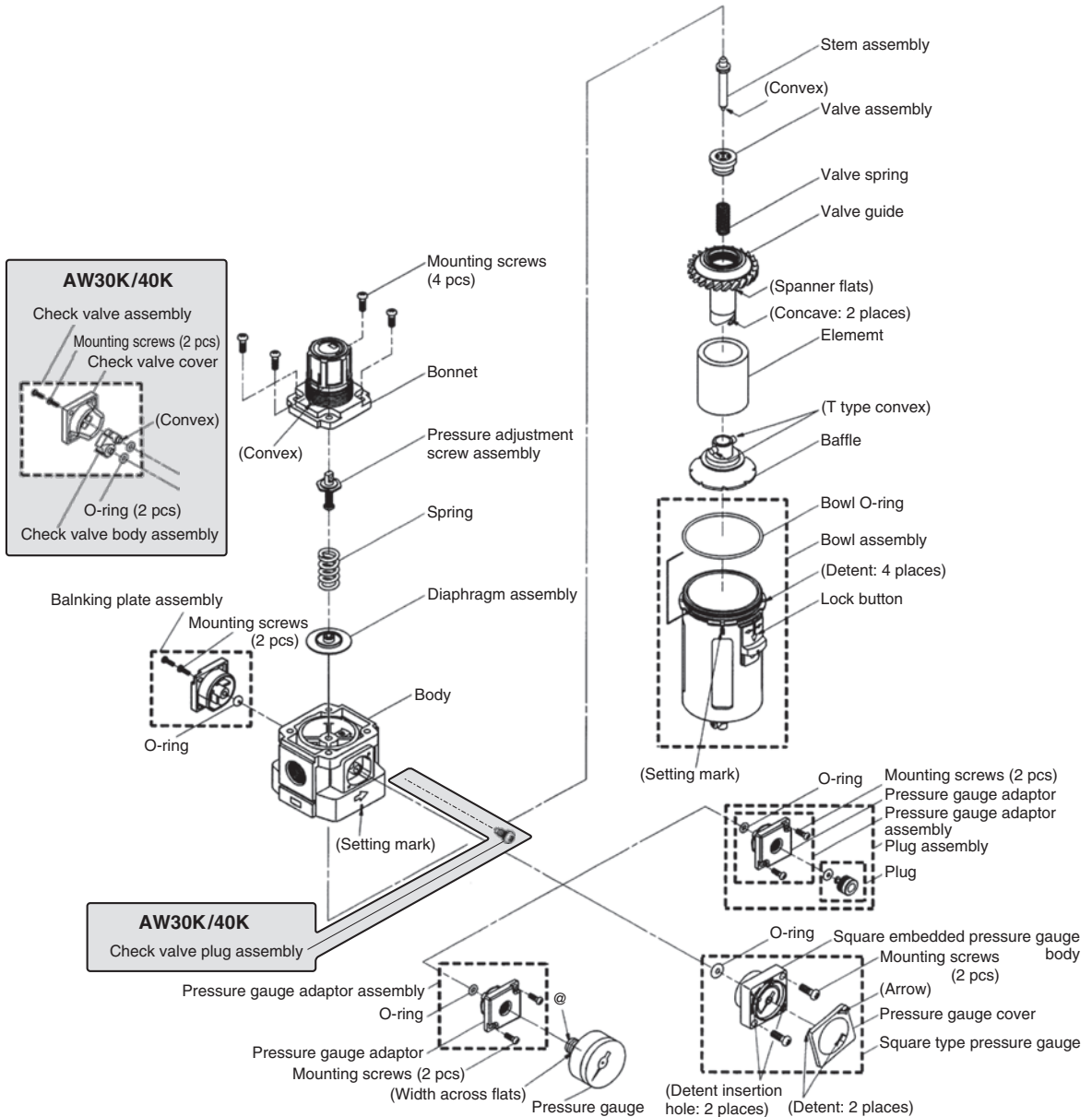

Note.) It is possible to mount square embedded pressure gauge or pressure gauge adaptor assembly or plug assembly instead of blanking plate assembly.

AW30K/40K

Note) The flow direction can be changed by taking off the check valve assembly, and replacing it with the square embedded gauge, pressure gauge adaptor assembly and plug assembly.

AW60(K) Exploded View 4

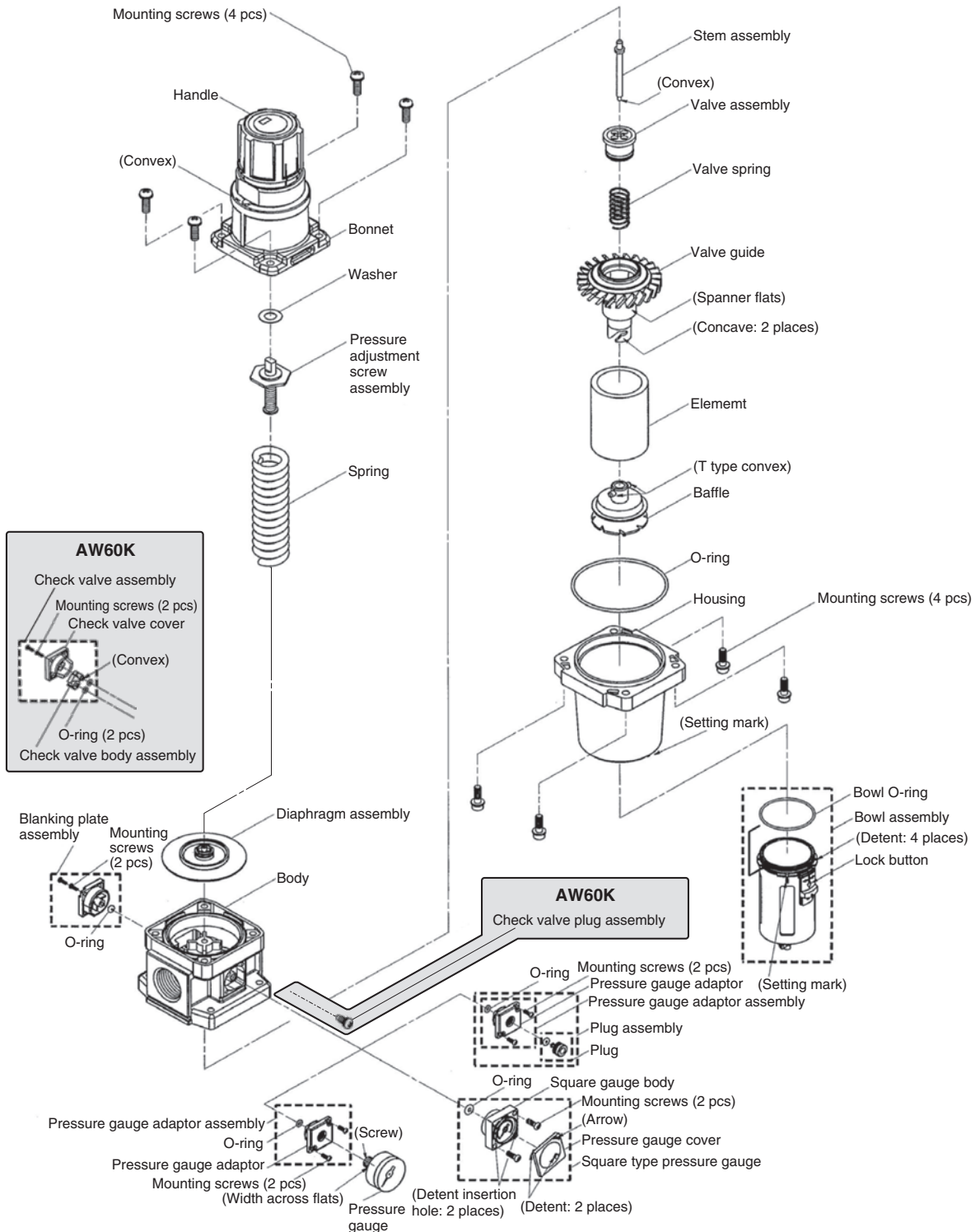

Note) It is possible to mount square embedded pressure gauge or pressure gauge adaptor assembly or plug assembly instead of Blanking plate assembly.

AW60K
 Note) The flow direction can be changed by taking off the check valve assembly, and replacing it with the square embedded gauge, pressure gauge adaptor assembly and plug assembly.

- Actuators
- Modular F.R.L.
Pressure Control Equipment
- Air Preparation
Equipment
- Industrial Filters
- Replacement
Procedure
- Actuators
- Modular F.R.L.
Pressure Control Equipment
- Industrial Filters

AW10(K)/20(K)/30(K)/40(K) Bracket Assembly, Panel Mount Exploded View 5

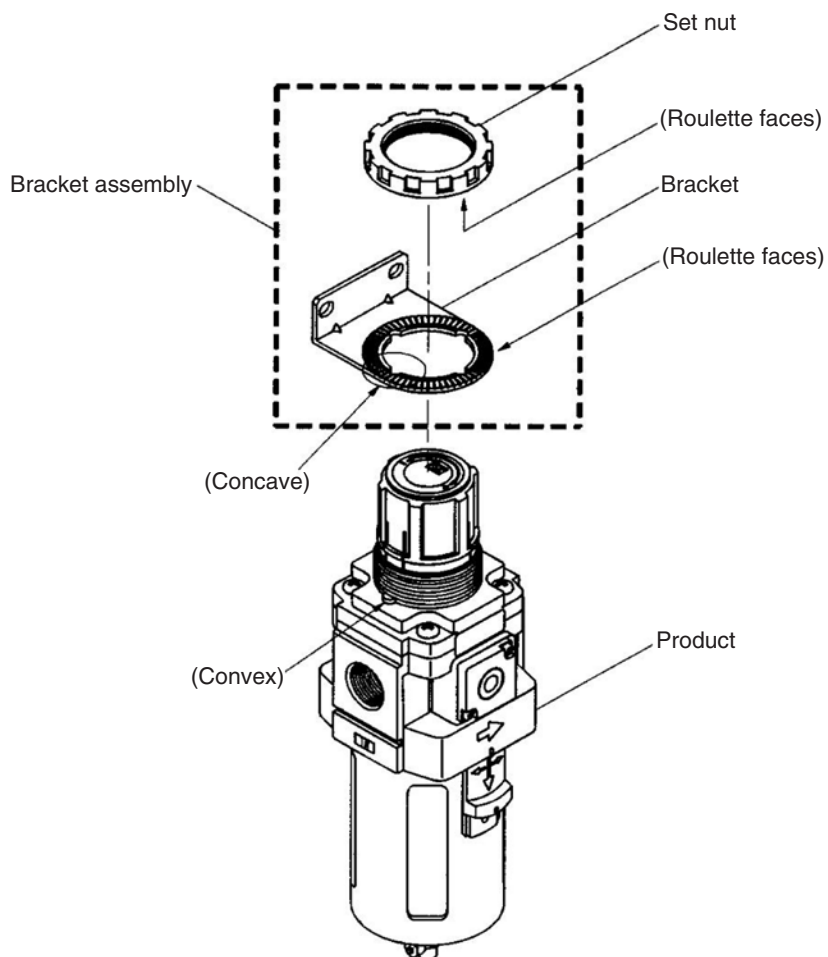

Note) Set nut and bracket for AW10 is not equipped with roulette face.
Product and bracket for AW10 is not equipped with convex and concave to mate.

AW60(K) Bracket Assembly Exploded View 6

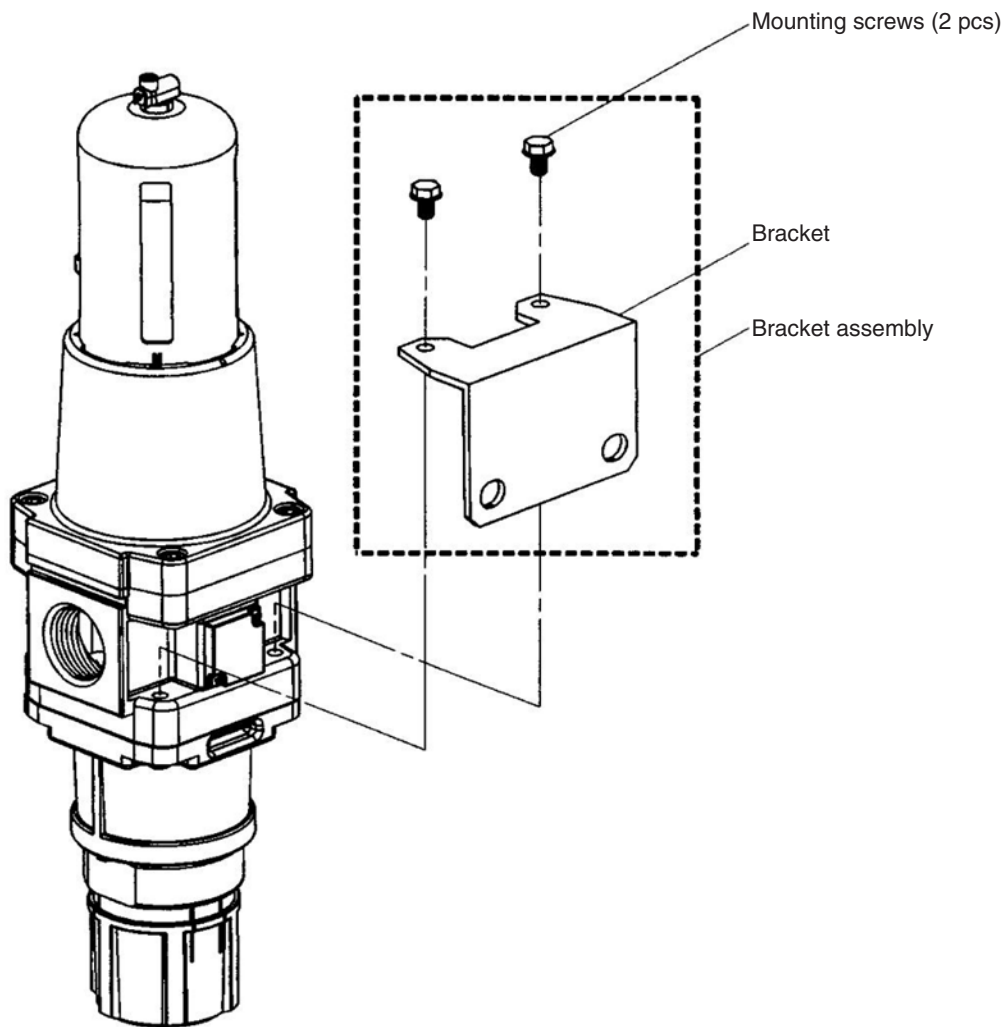

Actuators

Modular F.R.L.
Pressure Control Equipment

Air Preparation
Equipment

Industrial Filters

Replacement
Procedure

Actuators

Modular F.R.L.
Pressure Control Equipment

Industrial Filters

Warning

Before replacement, ensure that the regulator is not pressurized.

Rotate the pressure adjusting handle to zero.

Replace referring to "Exploded View".

After replacement, ensure that specified function is satisfied and external leakage is not found before starting operation.

1. Bowl Assembly/Element

Applicable model	Process	Procedure	Tools	Check item
AW10	Disassembly	1) Remove the bowl assembly. Hold the bowl assembly by hand and rotate counterclockwise to remove the bowl assembly. If the bowl assembly is tightened too much to be removed, use hook spanner until it can be loosened by hand.	(Hook spanner Nominal: 25/28)	—
		2) Remove the baffle and element. Rotate the baffle by hand and counterclockwise to remove the baffle and element.	—	—
	Assembly	3) Mount the element. Mount the element to the element guide. (Directionless)	—	—
		4) Mount the baffle. Hold the baffle by hand to rotate it clockwise and mount the element. Baffle has mount direction. Refer to the "Exploded View". For baffle tightening torque, refer to the "Check item".	Spanner Nominal: 16	Tightening torque: 0.35 ± 0.05 N·m
		5) Mount the bowl assembly. Hold the bowl assembly by hand and rotate clockwise. Do not use tool for mounting because the bowl may be damaged. Refer to the "Check item" for referential tightening torque.	—	Referential tightening torque: 1.5 N·m
AW20(K)	Disassembly	1) Remove the bowl assembly. Hold the bowl assembly by hand and rotate counterclockwise to remove the bowl assembly. If the bowl assembly is tightened too much to be removed, use hook spanner until it can be loosened by hand.	(Hook spanner Nominal: 34/38)	—
		2) Remove the baffle and element. Rotate the baffle by hand and counterclockwise to remove the baffle and element.	—	—
	Assembly	3) Mount the element. Mount the element to the valve guide.	—	—
		4) Mount the baffle. Insert the baffle so that concave on the valve guide could meet T convex on the baffle. And rotate it clockwise manually until feeling snap fit (approx. 110°) to fix to the element.	—	—
		5) Mount the bowl assembly. Hold the bowl assembly by hand and rotate clockwise. Do not use tool for mounting because the bowl may be damaged. Refer to the "Check item" for referential tightening torque.	—	Referential tightening torque: 2.2 N·m
AW30(K) AW40(K) AW60(K)	Disassembly	1) Remove the bowl assembly Push the bowl assembly lock button. Lifting the bowl assembly, rotate the assembly 45 degree (right or left) to pull out the assembly.	—	—
		2) Remove the baffle and element. Rotate the baffle by hand and counterclockwise to remove the baffle and element.	—	—
	Assembly	3) Mount the element. Mount the element to the valve guide.	—	—
		4) Mount the baffle. Insert the baffle so that concave on the valve guide could meet T convex on the baffle. And rotate it clockwise manually until feeling snap fit (approx. 110°) to fix to the element.	—	Direction of baffle. For element convex side.
		5) Mount the bowl assembly. Match the mating mark of the body and the bowl assembly to insert the assembly to the body. Rotate the assembly 45 degree (right or left) until the lock button is tossed up to mount the bowl assembly. Ensure the lock button is up.	—	Lock button is up.

2. Diaphragm Assembly

Applicable model	Process	Procedure	Tools	Check item						
AW10	Disassembly	1) Remove the bonnet assembly. Hold the bonnet with a spanner on the width across flat, and rotate counterclockwise to remove the bonnet assembly.	Spanner Nominal: 16	—						
		2) Remove the piston assembly from the bonnet assembly. Pull out the piston assembly facing the handle downwards. Otherwise, pressure adjustment screw assembly or spring fall off.	—	—						
	Assembly	3) Mount the piston assembly to the bonnet assembly. Insert the piston assembly to the bonnet so that the piston assembly convex faces the body. If pressure adjusting screw or pressure adjusting spring is not mounted on the bonnet, mount it before mounting the piston assembly.	—	—						
		4) Ensure the chamber is mounted on the body. If the chamber is removed during disassembly, mount the chamber ensuring the right direction of the chamber. Convex of the chamber shall face the bonnet.	—	Presence of chamber. Mounting direction						
		5) Mount the bonnet assembly to the body. Hold the bonnet assembly with a spanner on the width across flat, and rotate the body clockwise to settle. Refer to the "Check item" for the tightening torque.	Spanner Nominal: 16	Tightening torque: 1.8 ± 0.3 N·m						
AW20(K) AW30(K) AW40(K) AW60(K)	Disassembly	1) Remove the bonnet. Rotate four mounting screws counterclockwise with Phillips head screw driver to remove the bonnet from the body.	Phillips head screw driver	—						
		2) Remove parts in order of the pressure adjustment screw assembly, spring, and the diaphragm assembly. Please be noted that the diaphragm assembly adheres to the bonnet if disassemble parts with the handle facing downwards.	—	—						
	Assembly	3) Mount parts to the body in order of the diaphragm assembly, spring, and pressure adjustment screw.	—	Direction of pressure adjustment screw assembly and diaphragm assembly						
		4) Mount the bonnet to the body. Mount the convex IN side of the bonnet to the body, and tighten half way with 4 mounting screws with a Phillips head screw driver. Then, tighten the screws completely in a diagonal pattern with the indicated tightening torque.	Phillips head screw driver	Tightening torque <table border="1" style="width: 100%; border-collapse: collapse;"> <tr> <td style="text-align: left;">AW20</td> <td style="text-align: center;">2.15 ± 0.3 N·m</td> </tr> <tr> <td style="text-align: left;">AW30</td> <td style="text-align: center;">2.35 ± 0.3 N·m</td> </tr> <tr> <td style="text-align: left;">AW40</td> <td style="text-align: center;">3.5 ± 0.3 N·m</td> </tr> <tr> <td style="text-align: left;">AW60</td> <td style="text-align: center;">4.50 ± 1.0 N·m</td> </tr> </table>	AW20	2.15 ± 0.3 N·m	AW30	2.35 ± 0.3 N·m	AW40	3.5 ± 0.3 N·m
AW20	2.15 ± 0.3 N·m									
AW30	2.35 ± 0.3 N·m									
AW40	3.5 ± 0.3 N·m									
AW60	4.50 ± 1.0 N·m									

3. Valve Assembly

Applicable model	Process	Procedure	Tools	Check item						
AW10	Disassembly	1) Remove valve guide after removing bowl assembly and element. Hold the valve guide with a spanner on the spanner flat to rotate it counterclockwise and remove the valve guide.	Spanner Nominal: 4	—						
		2) Remove the valve spring.	—	—						
		3) Remove the valve.	—	—						
	Assembly	4) Mount the valve. Mount the valve so that convex on the valve could be turned to the valve guide.	—	The convex surface of the valve is a valve guide side.						
		5) Mount the valve spring. Insert internal circumference of the valve spring to the convex on the valve.	—	—						
		6) Mount the valve guide. Hold the valve guide with a spanner on the spanner flat to rotate it clockwise and mount the valve guide. Refer to the "Check item" for the tightening torque.	Spanner Nominal: 4	Tightening torque: 0.35 ± 0.05 N·m						
AW20(K) AW30(K) AW40(K)	Disassembly	1) Remove valve guide after removing bowl assembly and element. Hold the valve guide with a spanner on the spanner flat to rotate it counterclockwise and remove the valve guide.	Spanner Nominal: <table border="1" style="width: 100%; border-collapse: collapse;"> <tr> <td style="text-align: left;">AW20(K)</td> <td style="text-align: center;">7</td> </tr> <tr> <td style="text-align: left;">AW30(K)</td> <td style="text-align: center;">17</td> </tr> <tr> <td style="text-align: left;">AW40(K)</td> <td style="text-align: center;">21</td> </tr> </table>	AW20(K)	7	AW30(K)	17	AW40(K)	21	—
AW20(K)	7									
AW30(K)	17									
AW40(K)	21									

Actuators
 Modular F.R.L. Pressure Control Equipment
 Air Preparation Equipment
 Industrial Filters
 Replacement Procedure
 Actuators
 Modular F.R.L. Pressure Control Equipment
 Industrial Filters

Series AW10 to 60/AW20K to 60K Replacement Procedure of Diaphragm 3

Applicable model	Process	Procedure	Tools	Check item
AW20(K) AW30(K) AW40(K)	Disassembly	2) Remove the valve spring.	—	—
		3) Remove the valve assembly.	—	—
	Assembly	4) Mount the valve assembly. Mate the stem convex and the valve center hole.	—	Positioning the stem and the valve (centering)
		5) Mount the valve spring. Insert the valve spring to the valve hole.	—	—
		6) Mount the valve guide. Hold the valve guide with a spanner on the spanner flat to rotate it clockwise and mount the valve guide. Refer to the "Check item" for the tightening torque.	Spanner Nominal: AW20(K) 7 AW30(K) 17 AW40(K) 21	Tightening torque: AW20(K) 0.8 ± 0.1 N·m AW30(K) 2.35 ± 0.3 N·m AW40(K) 3.5 ± 0.3 N·m
AW60(K)	Disassembly	1) Remove the bowl assembly, housing, and element. Remove a housing from a body by rotating 4 mounting screws counterclockwise with a hexagon wrench key.	Hexagon wrench key Nominal: 5	—
		2) Remove the valve guide. Hold the valve guide with a spanner on the spanner flat to rotate it counterclockwise and remove the valve guide.	Spanner Nominal: 30	—
		3) Remove the valve spring.	—	—
		4) Remove the valve assembly.	—	—
	Assembly	5) Mount the valve assembly. Mate the stem convex and the valve center hole.	—	Positioning the stem and the valve (centering)
		6) Mount the valve spring. Insert the valve spring to the valve hole.	—	—
		7) Mount the valve guide. Hold the valve guide with a spanner on the spanner flat to rotate it clockwise and mount the valve guide. Refer to the "Check item" for the tightening torque.	Spanner Nominal: 30	Tightening torque: 6.5 ± 0.3 N·m
		8) Mount the housing. Mount an O-ring on the body, assemble the housing, and tighten the 4 mounting screws temporary. Tighten the screws additionally and evenly with the tightening torque shown on the right using the hexagon wrench key.	Hexagon wrench key Nominal: 5	Tightening torque: 4.5 ± 1.0 N·m

4. Bracket Assembly, Panel Mount

Applicable model	Process	Procedure	Tools	Check item
AW10(K) AW20(K) AW30(K) AW40(K)	Assembly	1) Mount the parts to the bracket (panel). Mate the bracket (panel) concave and the bonnet convex to mount the bracket.	—	—
		2) Settle the bracket (panel) with set nut. Rotate the set nut clockwise with a hook spanner (spanner for AW10) to settle the parts to the bracket (panel). Refer to the "Check item" for tightening torque. Set nut knurling surface shall face the bracket. (except AW10) When mounting with bracket, set nut tightened manually is adequate for general used. (except AW10)	AW10 Spanner Nominal: 24 AW20(K)/30(K)/40(K) Hook spanner Nominal AW20(K) 34/38 AW30(K) 52/55 AW40(K) 52/55	Tightening torque AW10 0.8 ± 0.1 N·m Tightening torque AW20(K) 2.0 ± 0.2 N·m AW30(K) 3.5 ± 0.3 N·m AW40(K) 4.0 ± 0.4 N·m
AW60(K)	Assembly	1) Mount the product to the bracket. Two mounting screws are tightened by spanner for holding.	Spanner Nominal: 10	Tightening torque: 2.6 N·m

5. Square Embedded Pressure Gauge

Applicable model	Process	Procedure	Tools	Check item
AW20(K) AW30(K) AW40(K) AW60(K)	Disassembly	1) Remove the pressure gauge cover. Rotate the pressure gauge cover 15 degree counterclockwise to pull out the pressure gauge cover.	—	—
		2) Remove the pressure gauge. Rotate two mounting screws counterclockwise with Phillips head screw driver to remove the pressure gauge and two mounting screws.	Phillips head screw driver	—

Series AW10 to 60/AW20K to 60K Replacement Procedure of Diaphragm 4

Applicable model	Process	Procedure	Tools	Check item
AW20(K) AW30(K) AW40(K) AW60(K)	Assembly	3) Ensure O-ring is mounted to the pressure gauge. Mount O-ring to the pressure gauge if the ring fall off.	—	Presence of O-ring
		4) Mount the pressure gauge. Rotate two mounting screws clockwise with Phillips head screw driver to mounting screws temporary. Then settle them with tightening torque in "Check item".	Phillips head screw driver	Tightening torque: 0.3 ± 0.05 N-m
		5) Mount the pressure gauge cover. Insert the pressure gauge mating two detent of the pressure gauge and holes for them so that the arrow of the pressure gauge cover comes upper right. Rotate the pressure gauge cover 15 degree opposite to the arrow to mount the pressure gauge.	—	—

6. Circular Pressure Gauge

Applicable model	Process	Procedure	Tools	Check item
AW10 AW20(K) AW30(K) AW40(K) AW60(K)	Disassembly	1) Remove the pressure gauge. Hold the pressure gauge with a spanner on the width across flat. Then, rotate the gauge counterclockwise to remove the gauge. Spanner for AW10 is a compact spanner.	Spanner Nominal: AW10 21 AW20(K) 12 AW30(K) AW40(K) 14 AW60(K)	—
		2) Wrap the pressure gauge thread with the seal tape leaving 1.5 to 2 threads from the end.	—	Wrap seal tape leaving 1.5 to 2 threads
	Assembly	3) Mount the pressure gauge. Hold the pressure gauge on the width across flat with a spanner, and rotate it clockwise to mount the circular pressure gauge. Use compact spanner for AW10. Refer to the "Check item" for tightening torque of pressure gauge.	Spanner Nominal: AW10 21 AW20(K) 12 AW30(K) AW40(K) 14 AW60(K)	Tightening torque: AW10 3 to 4 N-m AW20(K) 7 to 9 N-m AW30(K) AW40(K) 12 to 14 N-m AW60(K)

7. Pressure Gauge Adapter, Plug Assembly

Applicable model	Process	Procedure	Tools	Check item
AW20(K) AW30(K) AW40(K) AW60(K)	Disassembly	1) Remove the plug. Insert the hexagon wrench key to hexagon hole of hexagon plug. Rotate the plug counterclockwise to remove the plug.	Hexagon wrench key Nominal: AW20(K) 4 AW30(K) AW40(K) 6 AW60(K)	—
		2) Remove the pressure gauge adapter. Rotate two mounting screws counterclockwise with Phillips head screw driver to remove the pressure gauge and two mounting screws.	Phillips head screw driver	—
	Assembly	3) Confirm pressure gauge adapter has O-ring. If not, mount O-ring.	—	—
		4) Mount pressure gauge adapter. Rotate two mounting screws clockwise by Phillips head screw driver to fix pressure gauge adapter. Refer to the "Check item" for tightening torque of two screws.	Phillips head screw driver (Torque driver)	Tightening torque: 0.3 to 0.05 N-m
		5) Mount plug assembly. Insert hexagon wrench key into hexagon hole on the plug and rotate clockwise to fix the plug. Refer to the "Check item" for tightening torque of two screws.	Hexagon wrench key Nominal: AW20(K) 4 AW30(K) AW40(K) 6 AW60(K)	Tightening torque: AW20(K) 0.6 ± 0.05 N-m AW30(K) AW40(K) 1.0 ± 0.1 N-m AW60(K)

8. Plug

Applicable model	Process	Procedure	Tools	Check item
AW10	Disassembly	1) Remove the plug. Insert the hexagon wrench key to hexagon hole of hexagon plug. Rotate the plug counterclockwise to remove the plug.	Hexagon wrench key Nominal: 4	—

9. Blanking Plate Assembly

Applicable model	Process	Procedure	Tools	Check item
AW20(K) AW30(K) AW40(K) AW60(K)	Disassembly	1) Remove the blanking plate. Rotate two mounting screws counterclockwise with Phillips head screw driver to remove the blanking plate and two mounting screws.	Phillips head screw driver	—
	Assembly	2) Confirm blanking plate has O-ring. If not, mount O-ring.	—	—
		3) Mount the blanking plate. Rotate two mounting screws clockwise by Phillips head screw driver to fix blankin plate. Refer to the "Check item" for tightening torque of two screws.	Phillips head screw driver (Torque driver)	Tightening torque: 0.3 ± 0.05 N·m

10. Check Valve Assembly

Applicable model	Process	Procedure	Tools	Check item
AW20K AW30K AW40K AW60K	Disassembly	1) Remove the check valve cover. Rotate two mounting screws counterclockwise by Phillips head screw driver to remove the check valve cover.	Phillips head screw driver	—
		2) Remove the check valve assembly from the body. Pull and remove the check valve assembly. Then, ensure two O-rings don't fall out of the body.	—	—
	Assembly	1) Ensure two O-rings don't fall out of the body and mount them if they fall off.	—	—
		2) Insert convex on the check valve body into two inserting holes for the O-rings respectively.	—	Direction of check valve body assembly
		3) Mount the check valve cover. Rotate two mounting screws clockwise by Phillips head screw driver to fix the check valve cover to the body. Refer to the "Check item" for adequate tightening torque for the screws.	Phillips head screw driver (Torque driver)	Tightening torque: 0.3 ± 0.05 N·m

ARG20(K)/30(K)/40(K) Exploded View 1

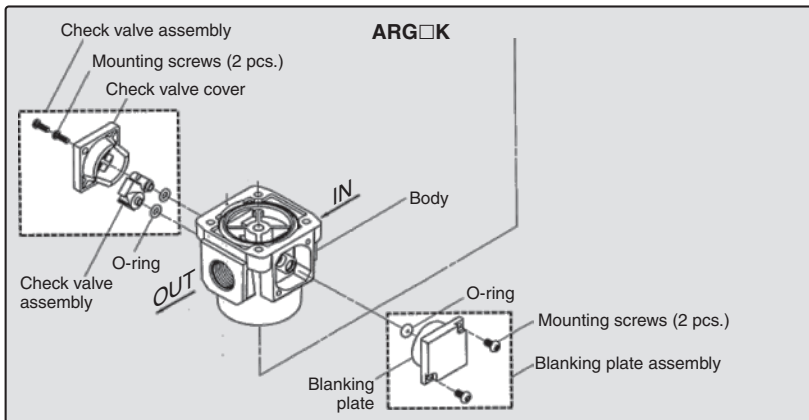
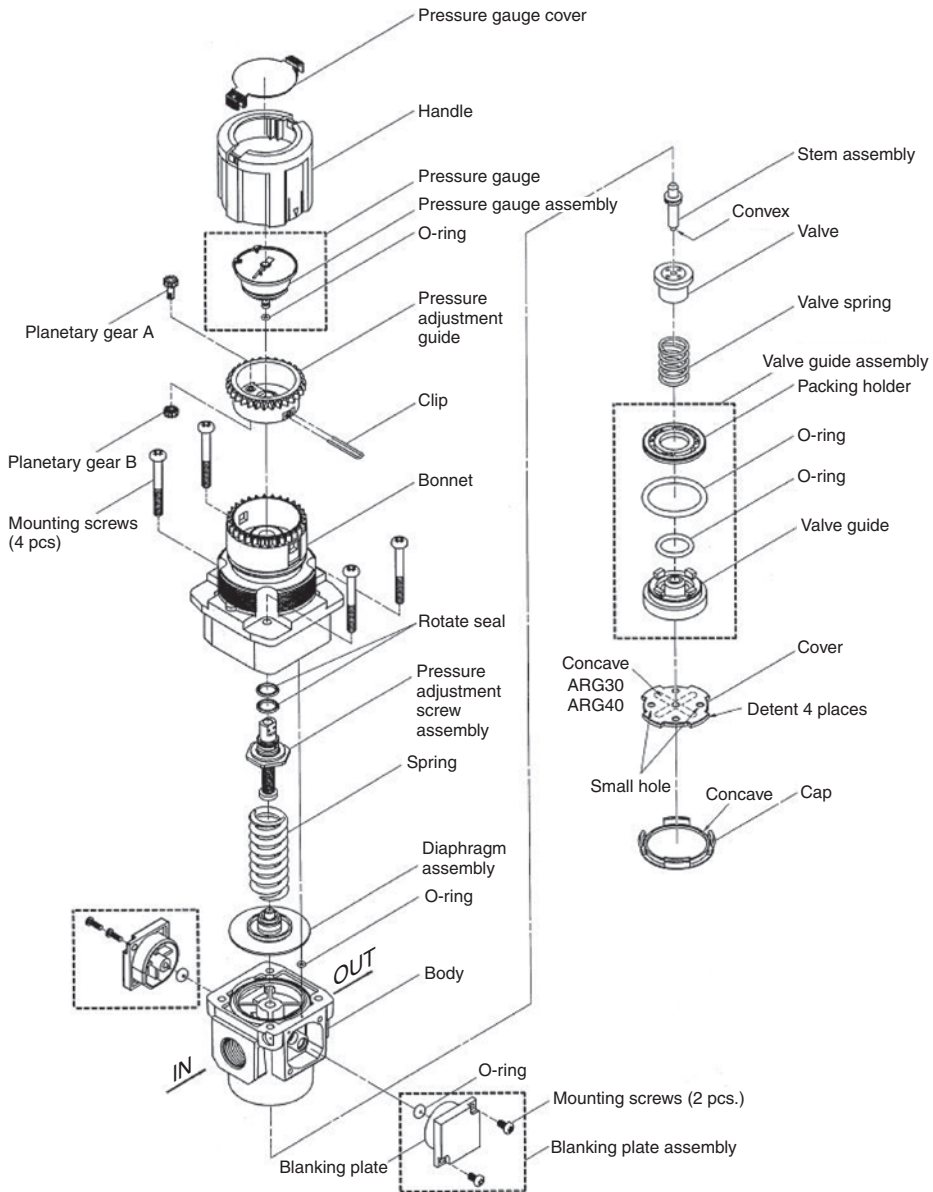

ARG20(K)/30(K)/40(K) Bracket Assembly, Panel Mount Exploded View 2

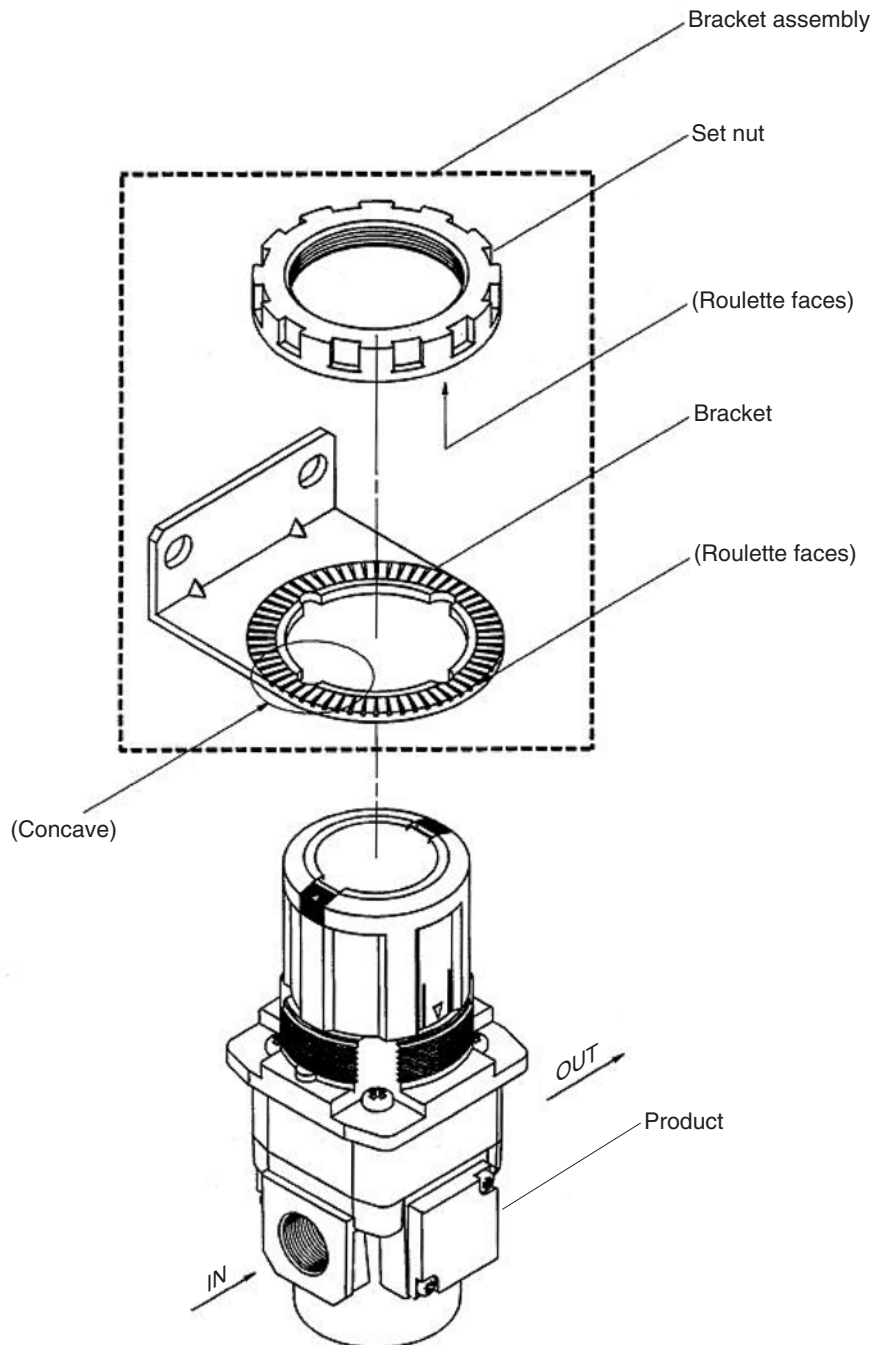

Series ARG20(K), 30(K), 40(K) Replacement Procedure of Diaphragm 1

Warning

Before replacement, ensure that the regulator is not pressurized.
 Rotate the pressure adjusting handle to zero.
 Replace referring to “Exploded View”
 After replacement, ensure that specified function is satisfied and external leakage is not found before starting operation.

1. Diaphragm Assembly

Applicable model	Process	Procedure	Tools	Check item				
ARG20(K) ARG30(K) ARG40(K)	Disassembly	1) Remove the bonnet assembly. Rotate the mounting screw counterclockwise with Phillips head screw driver to remove the bonnet from the body.	Phillips head screw driver	—				
		2) Remove parts in order of the spring and the diaphragm assembly. Please be noted that the diaphragm assembly adheres to the bonnet if disassemble parts with the handle facing downwards.	—	—				
	Assembly	3) Mount the diaphragm assembly first and then spring on the body.	—	Direction of diaphragm assembly				
		4) Mount the bonnet to the body. Mount the convex IN side of the bonnet to the body, and tighten half way with 4 mounting screws with a Phillips head screw driver. Then, tighten the screws completely in a diagonal pattern with the indicated tightening torque.	Phillips head screw driver	Tightening torque: <table border="1" style="font-size: small;"> <tr> <td>ARG20(K)</td> <td>2.15 ± 0.3 N·m</td> </tr> <tr> <td>ARG30(K)</td> <td>2.35 ± 0.3 N·m</td> </tr> <tr> <td>ARG40(K)</td> <td>3.5 ± 0.3 N·m</td> </tr> </table>	ARG20(K)	2.15 ± 0.3 N·m	ARG30(K)	2.35 ± 0.3 N·m
ARG20(K)	2.15 ± 0.3 N·m							
ARG30(K)	2.35 ± 0.3 N·m							
ARG40(K)	3.5 ± 0.3 N·m							

2. Valve Guide Assembly, Valve

Applicable model	Process	Procedure	Tools	Check item
ARG20(K) ARG30(K) ARG40(K)	Disassembly	1) Remove the cap. Insert the watchmakers screw driver in the gap between the body and the cap and dig up the cap.	Watchmakers screw driver	—
		2) Remove the cover. Insert the circular pliers into the 2 small holes of the cover, rotate 45 degrees to one side or the other and lift.	Circular pliers Nominal: 125	—
		3) Remove the valve guide assembly. Hold the valve guide with a needle nose pliers, and lift it.	Needle nose pliers	—
		4) Remove the valve spring.	—	—
		5) Remove the valve.	—	—
	Assembly	6) Mount the valve. Mate the stem convex and the valve center hole.	—	Positioning the stem and the valve (centering)
		7) Mount the valve spring. Insert the valve spring to the valve hole.	—	—
		8) Mount the valve guide assembly and the cover assembly to the body. Align the body groove and the cover clamp, push in the valve guide and cover assembly, insert the circular pliers into the 2 small holes of the cover and rotate 45 degrees to one side or the other to lock into place.	Circular pliers Nominal: 125	—
		9) Mount the cap. Mate the convex of the body cover and the concave of the cap, and push them in to settle. Ensure the end of the body and the cap are almost flat.	—	Orientation of the body and the cap. Body end and the cap are almost flat.

3. Bracket Assembly, Panel Mount

Applicable model	Process	Procedure	Tools	Check item
ARG20(K) ARG30(K) ARG40(K)	Assembly	1) Mount the parts to the bracket (panel). Mate the bracket (panel) concave and the bonnet convex to mount the bracket.	—	—
		2) Settle the bracket (panel) with set nut. Rotate the set nut clockwise with a hook spanner to settle the parts to the bracket (panel). Refer to the "Check item" for tightening torque. When mounting the bracket for ARG20(K)/30(K)/40(K), ensure that the roulette faces of the set nut and the bracket are mated appropriately. When mounting with bracket, set nut tightened manually is adequate for general used. (ARG20(K)/30(K)/40(K))	ARG20(K)/30(K)/40(K) Hook spanner Nominal: ARG20(K) 52/55 ARG30(K) 58/65 ARG40(K) 65/70	Tightening torque: ARG20(K) 2.5 ± 0.2 N·m ARG30(K) 3.5 ± 0.3 N·m ARG40(K) 4.0 ± 0.4 N·m

Series ARG20(K), 30(K), 40(K) Procedure of the Pressure Gauge Replacement and Angle Adjustment 1

⚠ Warning

Before replacement, ensure that the regulator is not pressurized.
Rotate the pressure adjusting handle to zero.

After replacement, ensure that specified function is satisfied and external leakage is not found before starting operation.

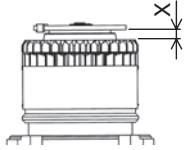
Applicable model	Process	Procedure	Tools	Check item							
ARG20(K) ARG30(K) ARG40(K)	Disassembly	1) Preparation Release the pressure adjustment handle lock with the pressure adjustment handle completely loosened.	—	Orange line can be seen between the pressure adjustment handle and the bonnet.							
		2) Removal of the handle Pull out the handle to remove at the position where ▼ mark of the handle and ▲ mark of the bonnet meet.	—	—							
		3) Removal of the clip The clip becomes visible from the side window of the bonnet if ▲ mark of the bonnet and ▼ mark of the pressure adjustment guide meet, pull out the clip with tweezers. * Retate the pressure adjustment guide clockwise when matching the mark.	Tweezers	—							
		4) Removal of the pressure gauge Pull out the pressure gauge holding the outer circumference of the dial. * Don't touch the internal component of the pressure gauge (surrounded by dashed line). It may damage the indication accuracy of the pressure gauge.	—	—							
	Assembly	5) Setting the pressure gauge Hold the outer circumference of the dial and set the gauge at specified angle, and push in the gauge lightly. For reference, table 1 shows the gap dimension between the bottom surface of the dial and the top surface of the pressure adjustment guide after mounting the pressure gauge. Note 1) If the gauge does not enter by some interference when setting the pressure gauge, set the gauge by slightly rotating it in rotating direction. (The planet gear of the pressure adjustment guide and the sun gear integrated in the pressure gauge interfere each other.) Note 2) Set the pressure gauge completely. Note 3) The end of the pressure gauge has greased O-ring. Attention should be taken so that dust and particle not enter to the pressure gauge.	—	 <p>FIG. 1. Gap dimension</p> <table border="1"> <thead> <tr> <th></th> <th>ARG20(K)</th> <th>ARG30(K)</th> <th>ARG40(K)</th> </tr> </thead> <tbody> <tr> <td>X dimension (Reference value)</td> <td>2.6 mm</td> <td>3.3 mm</td> <td>3.3 mm</td> </tr> </tbody> </table>		ARG20(K)	ARG30(K)	ARG40(K)	X dimension (Reference value)	2.6 mm	3.3 mm
	ARG20(K)	ARG30(K)	ARG40(K)								
X dimension (Reference value)	2.6 mm	3.3 mm	3.3 mm								

Series ARG20(K), 30(K), 40(K) Procedure of the Pressure Gauge Replacement and Angle Adjustment 2

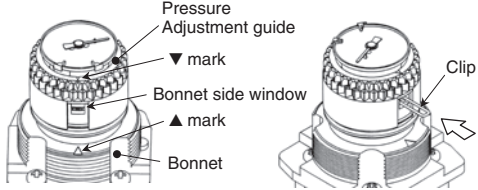
Applicable model	Process	Procedure	Tools	Check item
ARG20(K) ARG30(K) ARG40(K)	Assembly	<p>6) Setting the clip Insert the clip from the side window of the bonnet where ▲ mark of the pressure adjustment guide and ▼ mark of the bonnet meet. Use something sharp like tweezers when inserting the clip to the end. If the clip is not inserted to the end the handle may not rotate after setting the handle.</p> <p>Note 1) Clip is slightly tapered to the end to avoid falling off. Slightly open the end of the clip when setting the clip. Note 2) Following causes are possible when the clip is stuck in the middle.</p> <p>① The pressure adjustment screw is lower than the original position. (Gap is made between the pressure adjustment nut and the spring. When the pressure adjustment screw is completely loosened, the pressure adjustment screw may be lowered if excessive press force applied to the pressure adjustment screw.) Countermeasure ... Turn the pressure adjustment guide approx. 5 times clockwise (pressure rise direction).</p> <p>② Pressure gauge is not properly set. Countermeasure...5) See setting the pressure gauge.</p> 	Tweezers	—
		7) Setting the handle Set the handle, and finish.	—	—

AWG20 Exploded View 1

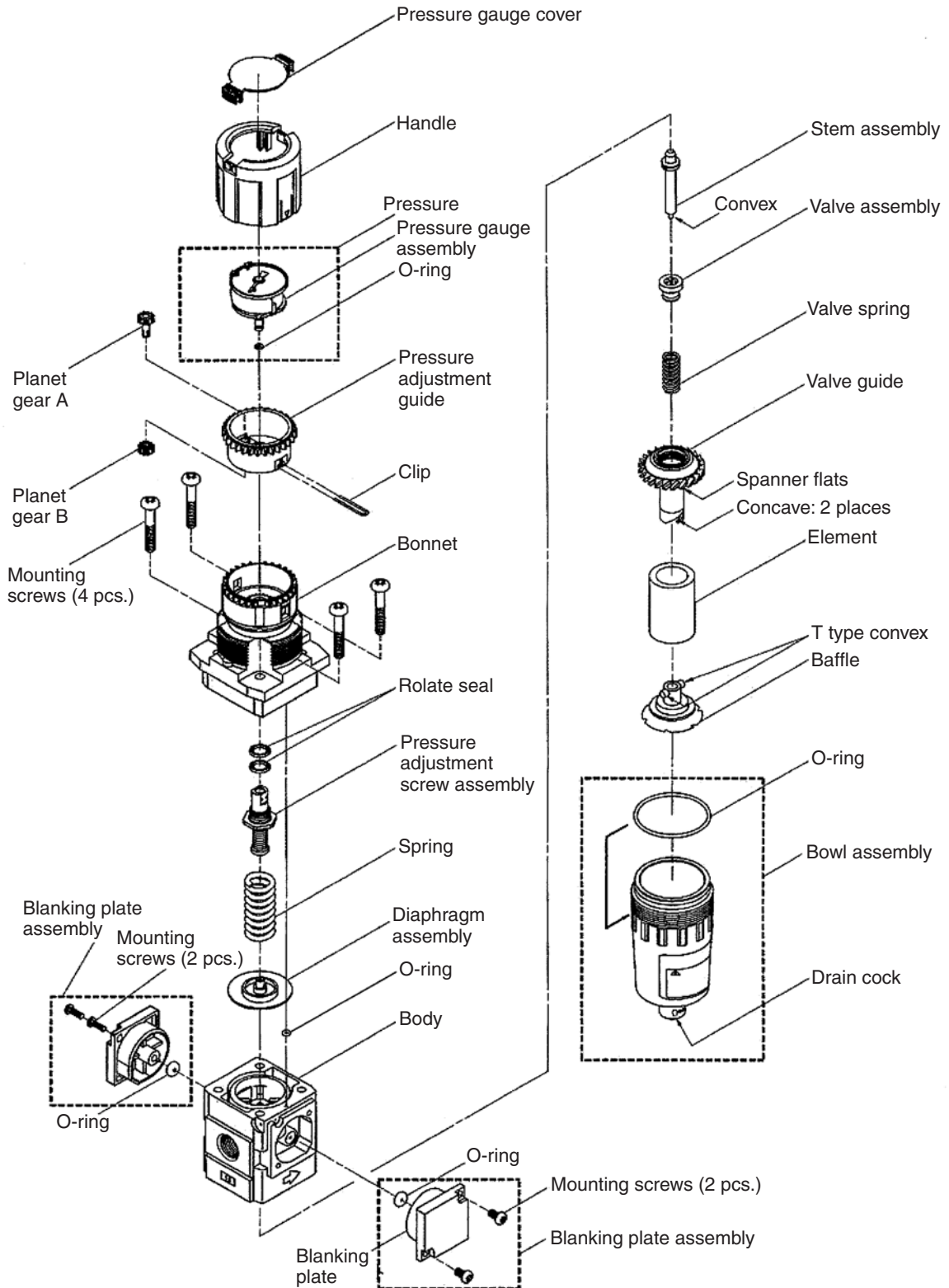

Actuators

Modular F.R.L.
Pressure Control Equipment

Air Preparation
Equipment

Industrial Filters

Replacement
Procedure

Actuators

Modular F.R.L.
Pressure Control Equipment

Industrial Filters

AWG30, 40 Exploded View 2

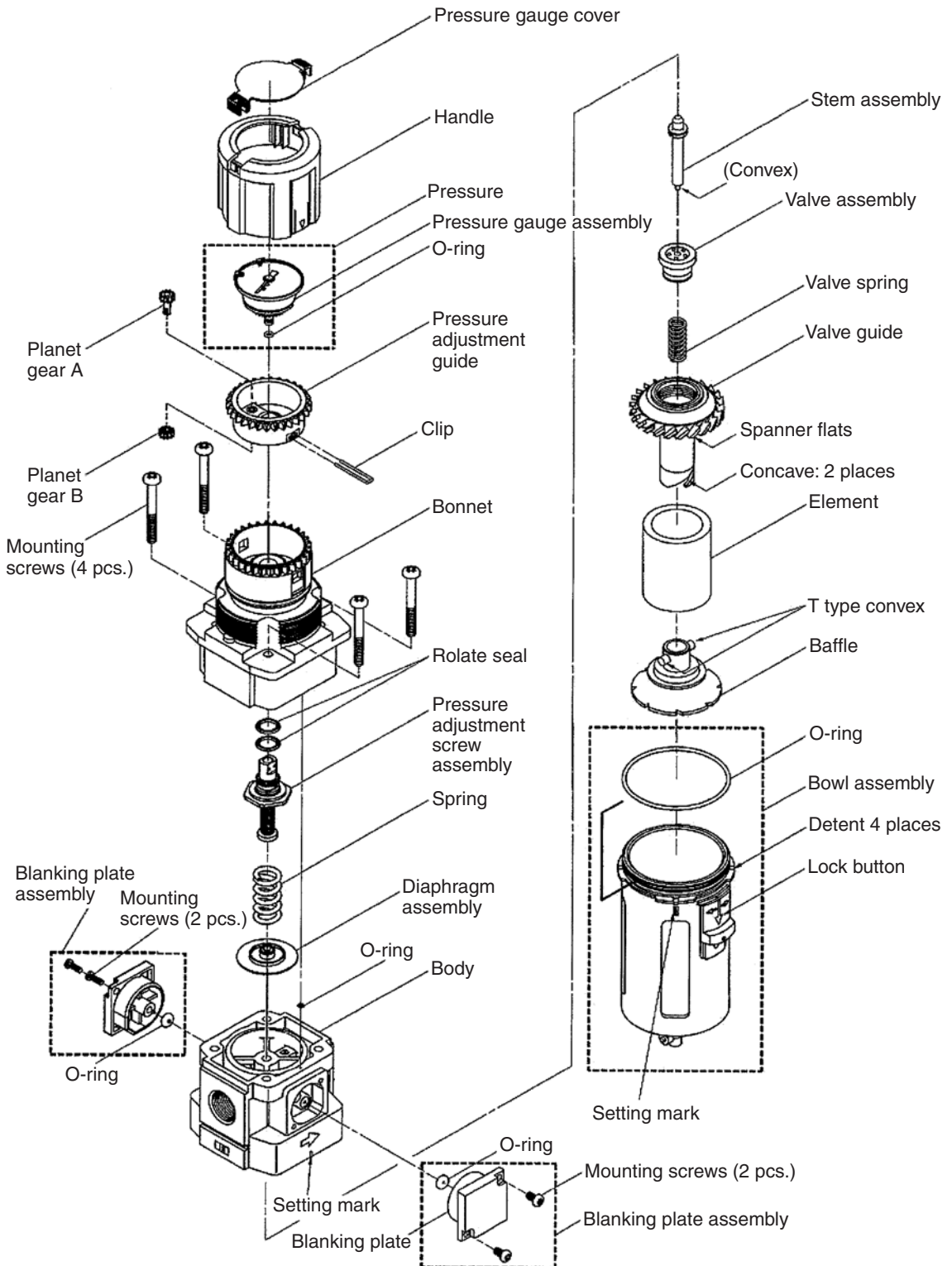

AWG20/30/40 Bracket Assembly, Panel Mount Exploded View 3

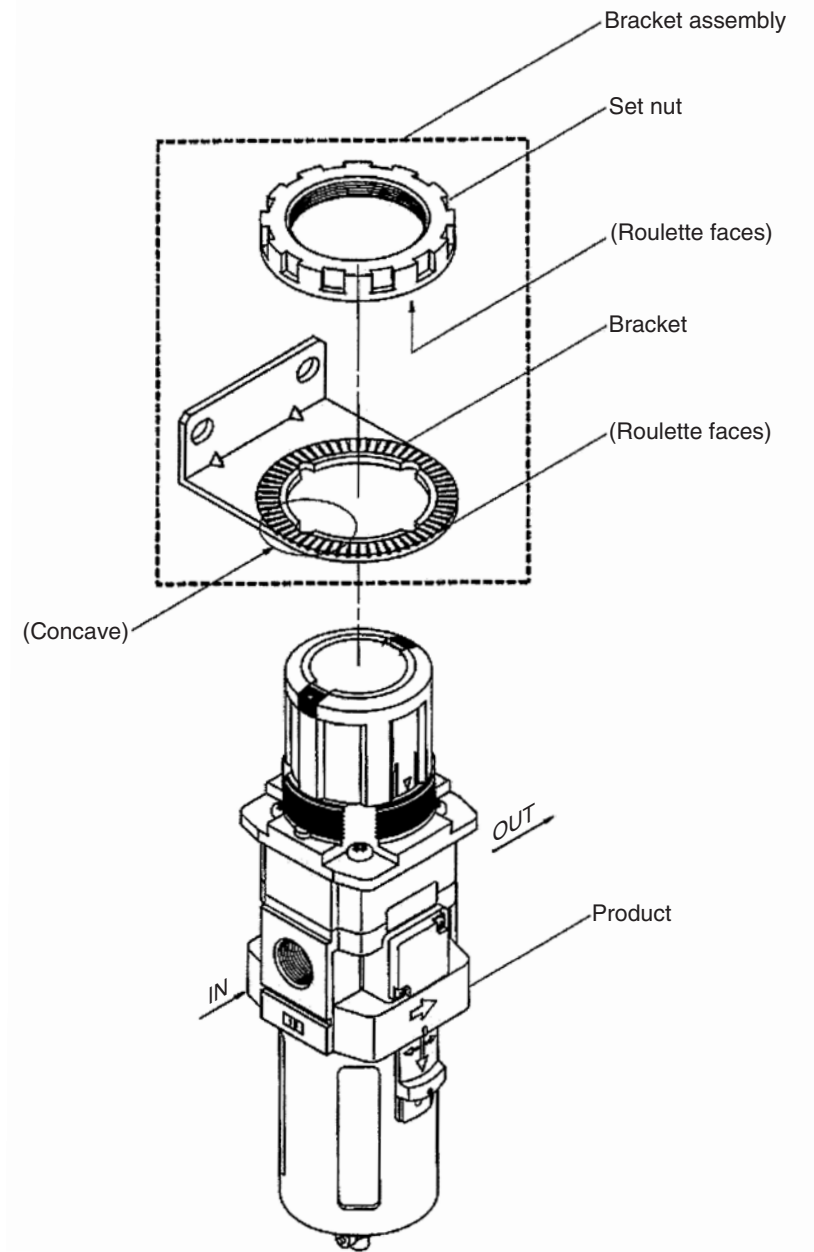

Actuators

Modular F.R.L.
Pressure Control Equipment

Air Preparation
Equipment

Industrial Filters

Replacement
Procedure

Actuators

Modular F.R.L.
Pressure Control Equipment

Industrial Filters

Series **AWG20, 30, 40** Replacement Procedure of Diaphragm 1

Warning

Before replacement, ensure that the regulator is not pressurized.
 Rotate the pressure adjusting handle to zero.
 Replace referring to “Exploded View”
 After replacement, ensure that specified function is satisfied and external leakage is not found before starting operation.

1. Bowl Assembly/Element

Applicable model	Process	Procedure	Tools	Check item
AWG20	Disassembly	1) Remove the bowl assembly. Hold the bowl assembly by hand and rotate counterclockwise to remove the bowl assembly. If the bowl assembly is tightened too much to be removed, use hook spanner until it can be loosened by hand.	(Hook spanner) (Nominal: 34/38)	—
		2) Remove the baffle and element. Rotate the baffle by hand and counterclockwise to remove the baffle and element.	—	—
	Assembly	3) Mount the element. Mount the element to the valve guide.	—	—
		4) Mount the baffle. Insert the baffle so that concave on the valve guide could meet T convex on the baffle. And rotate it clockwise manually until feeling snap fit (approx. 110°) to fix to the element.	—	—
		5) Mount the bowl assembly. Hold the bowl assembly by hand and rotate clockwise. Do not use tool for mounting because the bowl may be damaged. Refer to the “Check item” for referential tightening torque.	—	Referential tightening torque: 2.2 N·m
AWG30 AWG40	Disassembly	1) Remove the bowl assembly. Push the bowl assembly lock button. Lifting the bowl assembly, rotate the assembly 45 degree (right or left) to pull out the assembly.	—	—
		2) Remove the baffle and element. Rotate the baffle by hand and counterclockwise to remove the baffle and element.	—	—
	Assembly	3) Mount the element. Mount the element to the valve guide.	—	—
		4) Mount the baffle. Insert the baffle so that concave on the valve guide could meet T convex on the baffle. And rotate it clockwise manually until feeling snap fit (approx. 110°) to fix to the element.	—	Direction of baffle. For element convex side.
		5) Mount the bowl assembly. Match the mating mark of the body and the bowl assembly to insert the assembly to the body. Rotate the assembly 45 degree (right or left) until the lock button is tossed up to mount the bowl assembly. Ensure the lock button is up.	—	Lock button is up.

2. Diaphragm Assembly

Applicable model	Process	Procedure	Tools	Check item				
AWG20 AWG30 AWG40	Disassembly	1) Remove the bonnet assembly. Rotate the set screw counterclockwise with Phillips head screw driver to remove the bonnet from the body.	Phillips head screw driver	—				
		2) Remove parts in order of the spring, and the diaphragm assembly. Please be noted that the diaphragm assembly adheres to the bonnet if disassemble parts with the handle facing downwards.	—	—				
	Assembly	3) Mount parts to the body in order of the diaphragm assembly, spring.	—	Diaphragm				
		4) Mount the bonnet to the body. Mount the convex IN side of the bonnet to the body, and tighten half way with 4 mounting screws with a Phillips head screw driver. Then, tighten the screws completely in a diagonal pattern with the indicated tightening torque.	Phillips head screw driver	Tightening torque <table border="1" style="width: 100%; border-collapse: collapse;"> <tr> <td style="text-align: center;">AWG20</td> <td style="text-align: center;">2.15 ± 0.3 N·m</td> </tr> <tr> <td style="text-align: center;">AWG30</td> <td style="text-align: center;">2.35 ± 0.3 N·m</td> </tr> <tr> <td style="text-align: center;">AWG40</td> <td style="text-align: center;">3.5 ± 0.3 N·m</td> </tr> </table>	AWG20	2.15 ± 0.3 N·m	AWG30	2.35 ± 0.3 N·m
AWG20	2.15 ± 0.3 N·m							
AWG30	2.35 ± 0.3 N·m							
AWG40	3.5 ± 0.3 N·m							

3. Valve Assembly

Applicable model	Process	Procedure	Tools	Check item
AWG20 AWG30 AWG40	Disassembly	1) Remove valve guide after removing bowl assembly and element. Hold the valve guide with a spanner on the spanner flat to rotate it counterclockwise and remove the valve guide.	Spanner Nominal: AWG20 7 AWG30 17 AWG40 21	—
		2) Remove the valve spring.	—	—
		3) Remove the valve assembly.	—	—
	Assembly	4) Mount the valve assembly. Mate the stem convex and the valve centerhole.	—	Positioning the stem and the valve (centering)
		5) Mount the valve spring. Insert the valve spring to the valve hole.	—	—
		6) Mount the valve guide. Hold the valve guide with a spanner on the spanner flat to rotate it clockwise and mount the valve guide. Refer to the "Check item" for the tightening torque.	Spanner Nominal: AWG20 7 AWG30 17 AWG40 21	Tightening torque AWG20 0.8 ± 0.1 N·m AWG30 2.35 ± 0.3 N·m AWG40 3.5 ± 0.3 N·m

4. Bracket Assembly, Panel mount

Applicable model	Process	Procedure	Tools	Check item
AWG20 AWG30 AWG40	Assembly	1) Mount the parts to the bracket (panel) Mate the bracket (panel) concave and the bonnet convex to mount the bracket.	—	—
		2) Settle the bracket (panel) with set nut. Rotate the set nut clockwise with a hook spanner to settle the parts to the bracket (panel). Refer to the "Check item" for tightening torque. Set nut knurling surface shall face the bracket (AWG20 to 40). When mounting with bracket, set nut tightened manually is adequate for general used. (AWG20 to 40)	AWG20/30/40 Hook spanner Nominal AWG20 52/55 AWG30 58/65 AWG40 65/70	Tightening torque AWG20 2.0 ± 0.2 N·m AWG30 3.5 ± 0.3 N·m AWG40 4.0 ± 0.4 N·m

Actuators

Modular F.R.L.
Pressure Control Equipment

Air Preparation
Equipment

Industrial Filters

Replacement
Procedure

Actuators

Modular F.R.L.
Pressure Control Equipment

Industrial Filters

Series **AWG20, 30, 40** Procedure of the Pressure Gauge Replacement and Angle Adjustment 1

Warning

Before replacement, ensure that the regulator is not pressurized.
 Rotate the pressure adjusting handle to zero.
 After replacement, ensure that specified function is satisfied and external leakage is not found before starting operation.

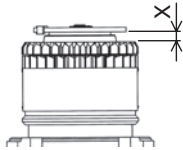
Applicable model	Process	Procedure	Tools	Check item							
AWG20 AWG30 AWG40	Disassembly	1) Preparation Release the handle lock with the pressure adjustment handle completely loosened.	—	Orange line can be seen between the handle and the bonnet.							
		2) Removal of the handle. Pull out the handle to remove at the position where ▼ mark of the handle and ▲ mark of the bonnet meet.	—	—							
		3) Removal of the clip. The clip becomes visible from the side window of the bonnet if ▲ mark of the bonnet and ▼ mark of the pressure adjustment guide meet, pull out the clip with tweezers. * Retate the pressure adjustment guide clockwise when matching the mark.	Tweezers	—							
		4) Removal of the pressure gauge. Pull out the pressure gauge holding the outer circumference of the dial. * Don't touch the internal component of the pressure gauge (surrounded by dashed line). It may damage the indication accuracy of the pressure gauge.	—	—							
	Assembly	5) Setting the pressure gauge Hold the outer circumference of the dial and set the gauge at specified angle, and push in the gauge lightly. For reference, table 1 shows the gap dimension between the bottom surface of the dial and the top surface of the pressure adjustment guide after mounting the pressure gauge. Note 1) If the gauge does not enter by some interference when setting the pressure gauge, set the gauge by slightly rotating it in rotating direction. (The planet gear of the pressure adjustment guide and the sun gear integrated in the pressure gauge interfere each other.) Note 2) Set the pressure gauge completely. Note 3) The end of the pressure gauge has greased O-ring. Attention should be taken so that dust and particle not enter to the pressure gauge.	—	 <p>FIG. 1. Gap dimension</p> <table border="1"> <thead> <tr> <th></th> <th>AWG20</th> <th>AWG30</th> <th>AWG40</th> </tr> </thead> <tbody> <tr> <td>X dimension (Reference value)</td> <td>2.6 mm</td> <td>3.3 mm</td> <td>3.3 mm</td> </tr> </tbody> </table>		AWG20	AWG30	AWG40	X dimension (Reference value)	2.6 mm	3.3 mm
	AWG20	AWG30	AWG40								
X dimension (Reference value)	2.6 mm	3.3 mm	3.3 mm								

Series **AWG20, 30, 40** Procedure of the Pressure Gauge Replacement and Angle Adjustment 2

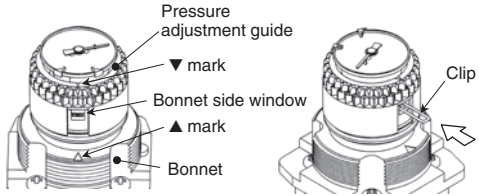
Applicable model	Process	Procedure	Tools	Check item
AWG20 AWG30 AWG40	Assembly	<p>6) Setting the clip. Insert the clip from the side window of the bonnet where ▲ mark of the pressure adjustment guide and ▼ mark of the bonnet meet. Use something sharp like tweezers when inserting the clip to the end. If the clip is not inserted to the end the handle may not rotate after setting the handle.</p> <p>Note 1) Clip is slightly tapered to the end to avoid falling off. Slightly open the end of the clip when setting the clip. Note 2) Following causes are possible when the clip is stuck in the middle.</p> <p>① The pressure adjustment screw is lower than the original position. (Gap is made between the pressure adjustment nut and the spring. When the pressure adjustment screw is completely loosened, the pressure adjustment screw may be lowered if excessive press force applied to the pressure adjustment screw.) Countermeasure ... Turn the pressure adjustment guide approx. 5 times clockwise (pressure rise direction).</p> <p>② Pressure gauge is not properly set. Countermeasure...5) See setting the pressure gauge.</p> <div style="text-align: center;">  </div>	Tweezers	—
		<p>7) Setting the handle Set the handle, and finish.</p>	—	—

Actuators

Modular F.R.L.
Pressure Control Equipment

Air Preparation Equipment

Industrial Filters

Replacement Procedure

Actuators

Modular F.R.L.
Pressure Control Equipment

Industrial Filters

AR425 Exploded View 1

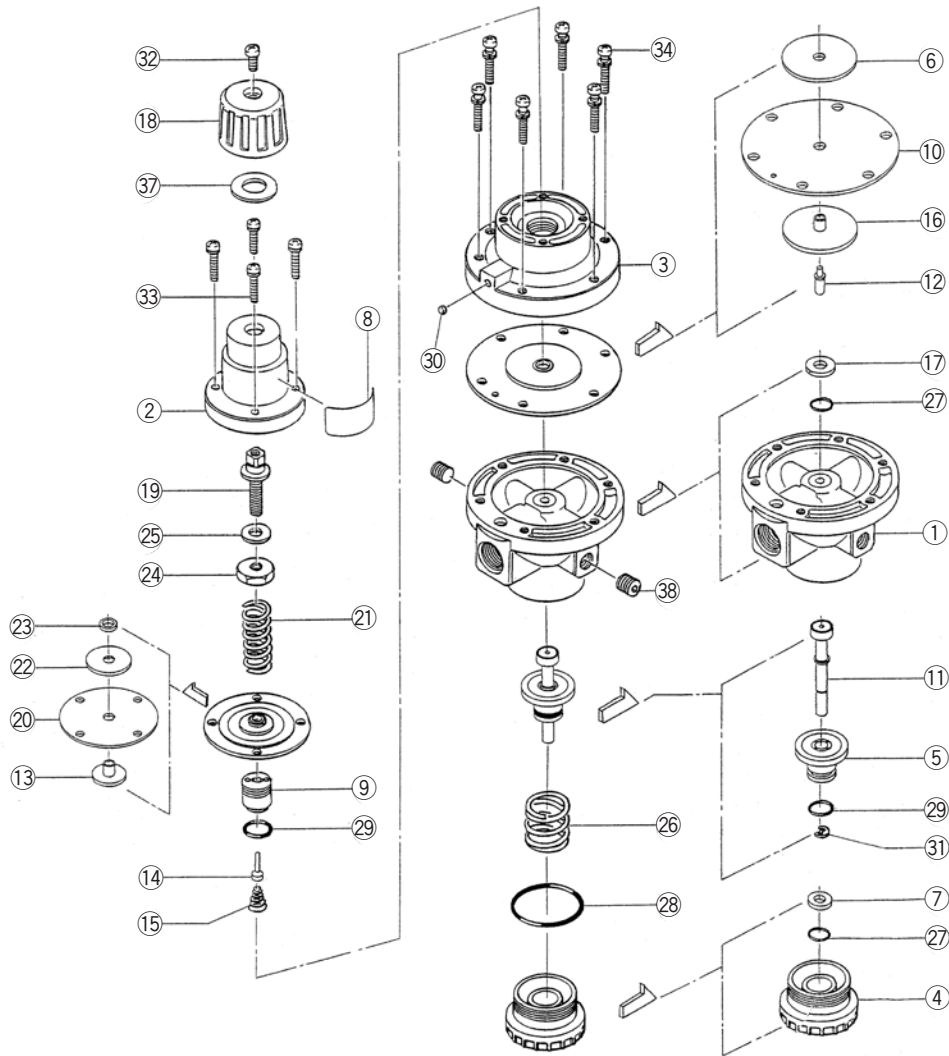

Component Parts

Item	Part Name	Qty	Remarks
①	Body	1	Chromate treatment
②	Bonnet	1	Chromate treatment
③	Chamber	1	Chromate treatment
④	Valve guide	1	Chromate treatment
⑤	Valve	1	Rubber lining material: HNBR
⑥	Diaphragm shell	1	Zinc chromate treatment
⑦	O-ring holder	1	Chromate treatment
⑧	Name plate	1	Complete product No. indicated
⑨	Valve seat	1	
⑩	Diaphragm	1	
⑪	Stem	1	Rubber lining material: HNBR
⑫	Rod	1	
⑬	Diaphragm holder	1	
⑭	Pilot valve	1	Rubber lining material: HNBR
⑮	Valve spring	1	
⑯	Diaphragm holder	1	
⑰	O-ring holder	1	Chromate treatment
⑱	Handle	1	

Item	Part Name	Qty	Remarks
⑲	Adjustment screw	1	Zinc chromate treatment
⑳	Diaphragm	1	
㉑	Spring	1	Zinc chromate treatment
㉒	Diaphragm shell	1	Chromate treatment
㉓	Washer	1	
㉔	Spring holder	1	Zinc chromate treatment
㉕	Seal	1	
㉖	Valve spring	1	
㉗	O-ring	2	JIS B2401 P5
㉘	O-ring	1	JIS B2401 G35
㉙	O-ring	2	JIS B2401 P10
㉚	Steel ball	1	ø4
㉛	Retaining ring	1	JIS B2805 4
㉜	Cross recessed round head screw	1	M5 x 0.8 x 8 Black Zn. chromate treatment
㉝	Cross recessed round head screw	4	M4 x 0.7 x 16 Nickel plating
㉞	Cross recessed round head screw	6	M5 x 0.8 x 22 Nickel plating
㉟	Flat washer	1	ø10.5 x ø20 x 1.2 Zinc chromate treatment
㊱	Hexagon socket head plug	2	R(PT) 1/4 Nickel plating

AR625 Exploded View 2

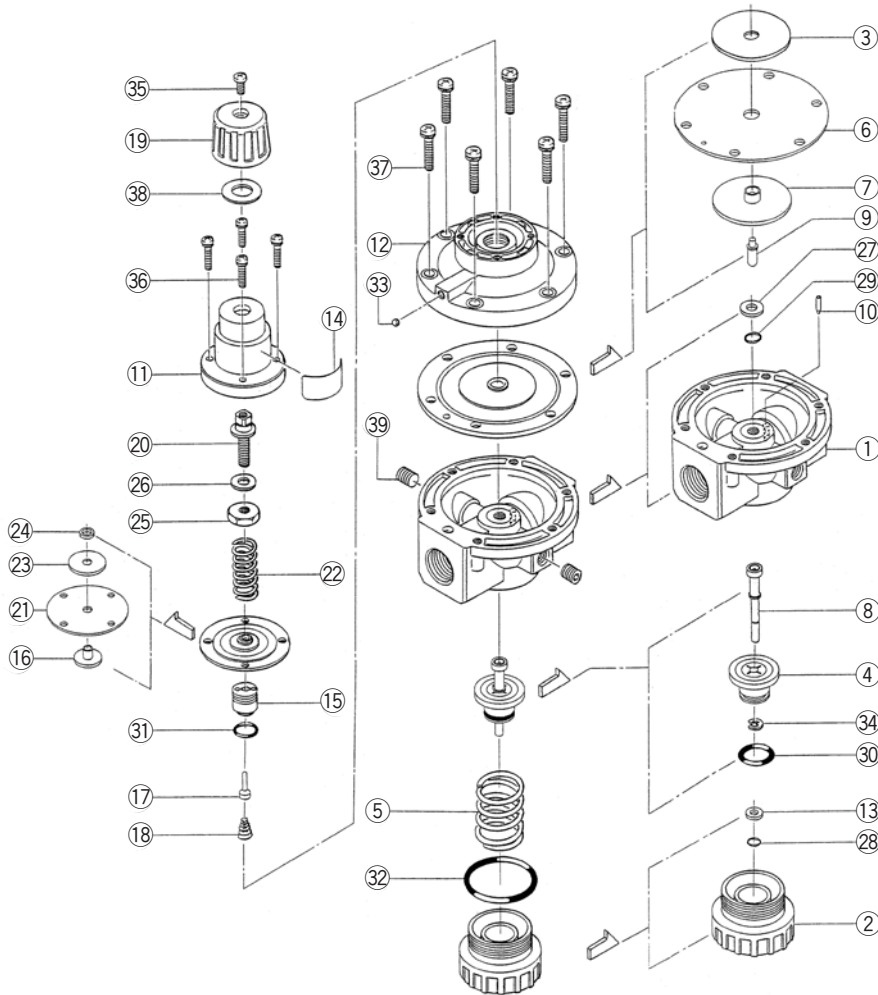

Component Parts

Item	Part Name	Qty	Remarks
①	Body	1	Chromate treatment
②	Valve guide	1	Chromate treatment
③	Diaphragm shell	1	Zinc chromate treatment
④	Valve	1	Rubber lining material: HNBR
⑤	Valve spring	1	
⑥	Diaphragm	1	
⑦	Diaphragm holder	1	
⑧	Stem	1	Rubber lining material: HNBR
⑨	Rod	1	
⑩	Static pressure tube	1	
⑪	Bonnet	1	Chromate treatment
⑫	Chamber	1	Chromate treatment
⑬	O-ring holder	1	Chromate treatment
⑭	Name plate	1	Complete product No. indicated
⑮	Valve seat	1	
⑯	Diaphragm holder	1	
⑰	Pilot valve	1	Rubber lining material: HNBR
⑱	Valve spring	1	
⑲	Handle	1	
⑳	Adjustment screw	1	Zinc chromate treatment

Item	Part Name	Qty	Remarks
⑳	Diaphragm	1	
㉑	Spring	1	Zinc chromate treatment
㉒	Diaphragm shell	1	Chromate treatment
㉓	Washer	1	
㉔	Spring holder	1	Zinc chromate treatment
㉕	Seal	1	
㉖	O-ring holder	1	Chromate treatment
㉗	O-ring	1	JIS B2401 P5
㉘	O-ring	1	JIS B2401 P6
㉙	O-ring	1	JIS B2401 P16
㉚	O-ring	1	JIS B2401 P10
㉛	O-ring	1	JIS B2401 G40
㉜	Steel ball	1	ø4
㉝	Retaining ring	1	JIS B2805 4
㉞	Cross recessed round head screw	1	M5 x 0.8 x 8 Black Zn. chromate treatment
㉟	Cross recessed round head screw	4	M4 x 0.7 x 16 Nickel plating
㊱	Cross recessed round head screw	6	M6 x 1 x 22 Nickel plating
㊲	Flat washer	1	ø10.5 x ø20 x 1.2 Zinc chromate treatment
㊳	Hexagon socket head plug	2	R(PT) 1/4 Nickel plating

AR825 Exploded View 3

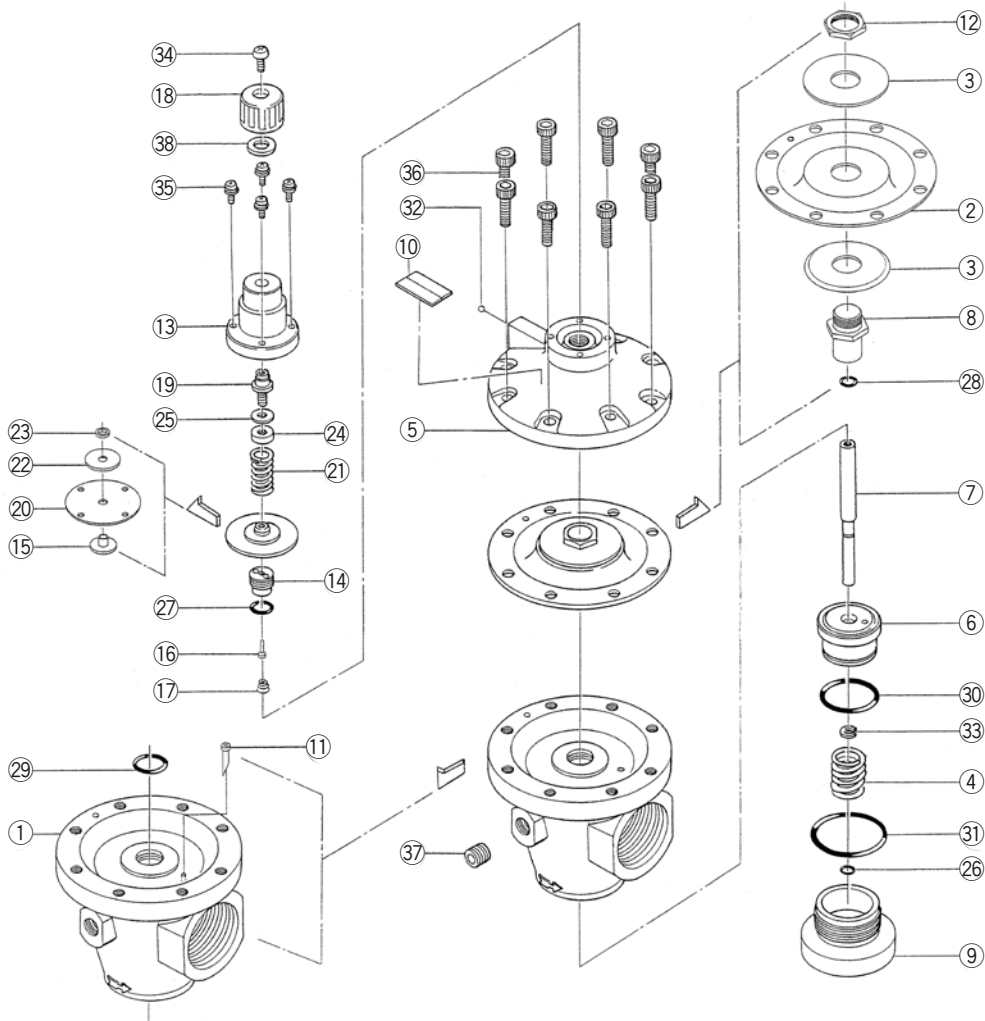

Component Parts

Item	Part Name	Qty	Remarks
①	Body	1	Chromate treatment
②	Diaphragm	1	
③	Diaphragm shell	2	Zinc Chromate treatment
④	Valve spring	1	
⑤	Chamber	1	Chromate treatment
⑥	Valve	1	Rubber lining material: HNBR
⑦	Stem	1	
⑧	Diaphragm shell holder	1	
⑨	Valve guide	1	Chromate treatment
⑩	Name plate	1	Complete product No. indicated
⑪	Static pressure tube	1	
⑫	Set nut	1	
⑬	Bonnet	1	Chromate treatment
⑭	Valve seat	1	
⑮	Diaphragm holder	1	
⑯	Pilot valve	1	Rubber lining material: HNBR
⑰	Valve spring	1	
⑱	Adjustment screw	1	Zinc Chromate treatment

Item	Part Name	Qty	Remarks
⑳	Diaphragm	1	
㉑	Spring	1	Zinc Chromate treatment
㉒	Diaphragm shell	1	Chromate treatment
㉓	Washer	1	
㉔	Spring holder	1	Zinc Chromate treatment
㉕	Seal	1	
㉖	O-ring	1	JIS B2401 P7
㉗	O-ring	1	JIS B2401 P10
㉘	O-ring	1	
㉙	O-ring	1	JIS B2401 P20
㉚	O-ring	1	JIS B2401 P30
㉛	O-ring	1	JIS B2401 G50
㉜	Steel ball	1	φ4
㉝	Retaining ring	1	TE-23
㉞	Cross recessed round head screw	1	M5 x 0.8 x 8 Black Zinc chromate treatment
㉟	Cross recessed round head screw	4	M4 x 0.7 x 16 Nickel plating
㊱	Hexagon socket head cap screw	8	M8 x 1.25 x 18 Nickel plating
㊲	Hexagon socket head plug	2	R(PT) 1/4 Nickel plating
㊳	Flat washer	1	φ10.5 x φ20 x 1.2 Zinc Chromate treatment

AR925 Exploded View 4

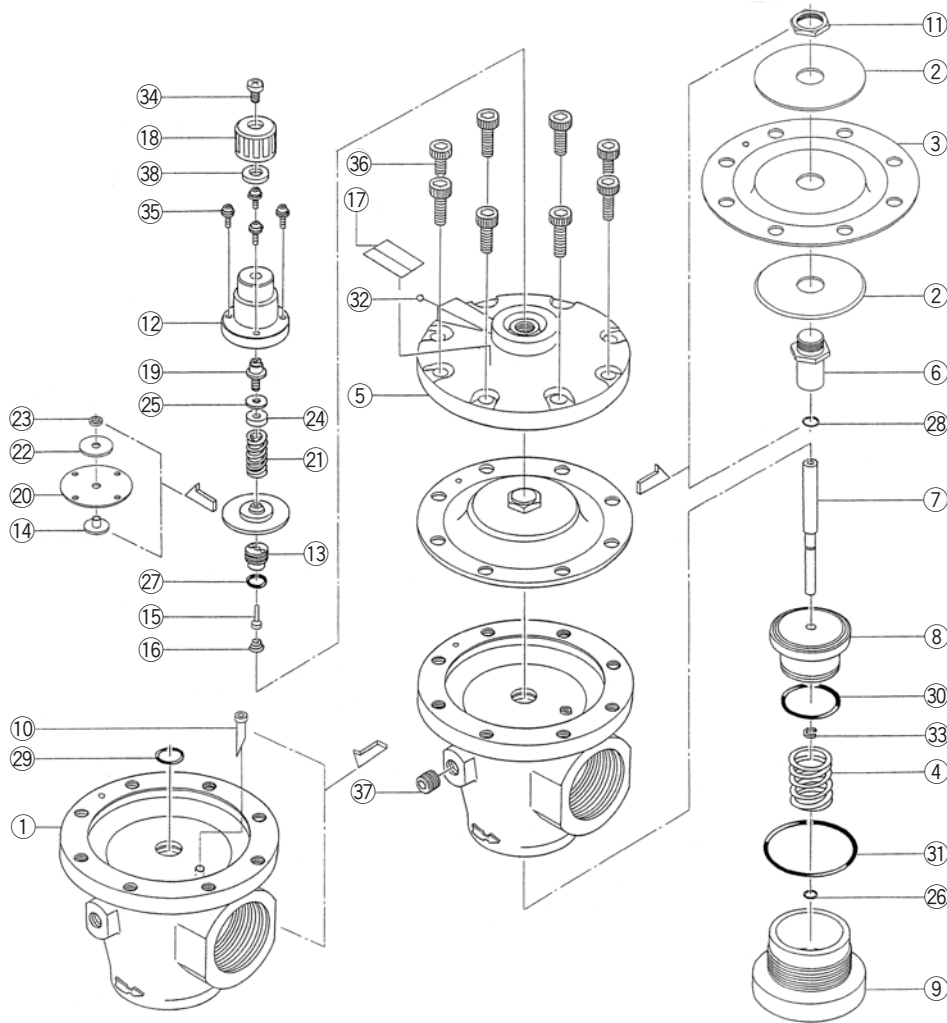

Component Parts

Item	Part Name	Qty	Remarks
①	Body	1	Chromate treatment
②	Diaphragm shell	2	Zinc chromate treatment
③	Diaphragm	1	
④	Valve spring	1	
⑤	Chamber	1	Chromate treatment
⑥	Diaphragm shell holder	1	
⑦	Stem	1	
⑧	Valve	1	Rubber lining material: HNBR
⑨	Valve guide	1	Chromate treatment
⑩	Static pressure tube	1	
⑪	Set nut	1	
⑫	Bonnet	1	Chromate treatment
⑬	Valve seat	1	
⑭	Diaphragm holder	1	
⑮	Pilot valve	1	Rubber lining material: HNBR
⑯	Valve spring	1	
⑰	Name plate	1	Complete product No. indicated
⑱	Handle	1	
⑲	Adjustment screw	1	Zinc chromate treatment

Item	Part Name	Qty	Remarks
⑳	Diaphragm	1	
㉑	Spring	1	Zinc chromate treatment
㉒	Diaphragm shell	1	Chromate treatment
㉓	Washer	1	
㉔	Spring holder	1	Zinc chromate treatment
㉕	Seal	1	
㉖	O-ring	1	JIS B2401 P7
㉗	O-ring	1	JIS B2401 P10
㉘	O-ring	1	
㉙	O-ring	1	JIS B2401 P20
㉚	O-ring	1	JIS B2401 P42
㉛	O-ring	1	JIS B2401 G70
㉜	Steel ball	1	φ5
㉝	Retaining ring	1	TE-23
㉞	Cross recessed round head screw	1	M5 x 0.8 x 8 Black Zinc chromate treatment
㉟	Cross recessed round head screw	4	M4 x 0.7 x 16 Nickel plating
㊱	Hexagon socket head cap screw	8	M10 x 1.5 x 20 Nickel plating
㊲	Hexagon socket head plug	2	R(PT) 1/4 Nickel plating
㊳	Flat washer	1	φ10.5 x φ20 x 1.2 Zinc chromate treatment

1. Element Replacement Method

To replace the element, carry out the procedure of 1-1 to 1-8 below while referring to the figure.

- 1-1. Using a hexagonal wrench, loosen the four hexagon socket head cap screws and remove the bowl. At this time, confirm that the O-ring groove in the bowl. If the O-ring is out of place, fit it into the O-ring groove.
- 1-2. Using a spanner, loosen the domed cap nut and remove it together with the gasket.
- 1-3. Pull the element downwards and remove it. If the element is difficult to remove, remove it by pushing it in the horizontal direction.
- 1-4. Coat the top of the element seal with a thin layer of grease, then set the seal so that it is uppermost and pass the tension bolt through it.
- 1-5. Pass the tension bolt through the gasket, then tighten the domed cap nut to fix the gasket in place.
- 1-6. Confirm that the O-ring is fitted in the O-ring groove in the bowl, and set the liquid level gauge so that it is facing the front.
- 1-7. Fix the bowl by tightening the four hexagon socket head cap screws.
- 1-8. Confirm that there is no leakage between the bowl and the housing.

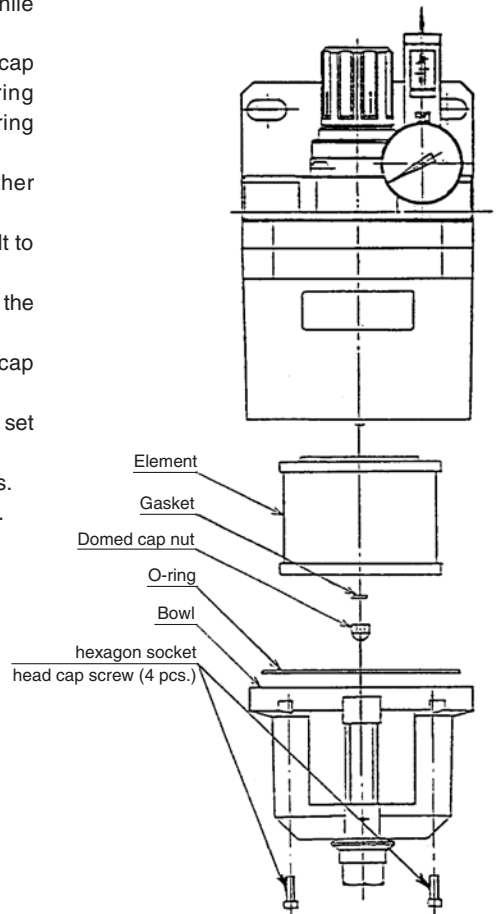

Series ARM5A/5B/5S Replacement Procedure of Diaphragm 1

⚠ Warning

Before replacement, ensure that the regulator is not pressurized.
 Rotate the pressure adjusting handle counterclockwise fully and to return it to zero.
 After replacement, ensure that specified function is satisfied and external leakage is not found before

1. Replacement of Pressure Gauge/Port Plug

Content	Replacement of pressure gauge/port plug	
Parts	Pressure gauge, port plug	
Tools	Watchmakers flat blade screw driver	
Process	Disassembly	Assembly
Procedure	1) Insert a watchmakers flat blade screw driver along with taper of hole A on OUT side of the body. 2) Hook the tip of the screw driver to the inserted clip, and pull out the clip. * As the clip may fly out, pull it slowly as holding it with a hand. 3) Pull out the mounted pressure gauge/port plug.	1) Insert the pressure gauge/port plug all the way in properly. 2) Put the clip back to the hole. Use the tip of the watchmakers flat blade screw driver to insert the clip to the end properly.
Check item	—	1) Presence of O-ring. (If dust or particles are remained on the O-ring it may cause air leakage. Therefore take measures to prevent them from attaching on the O-ring.)

Exploded view

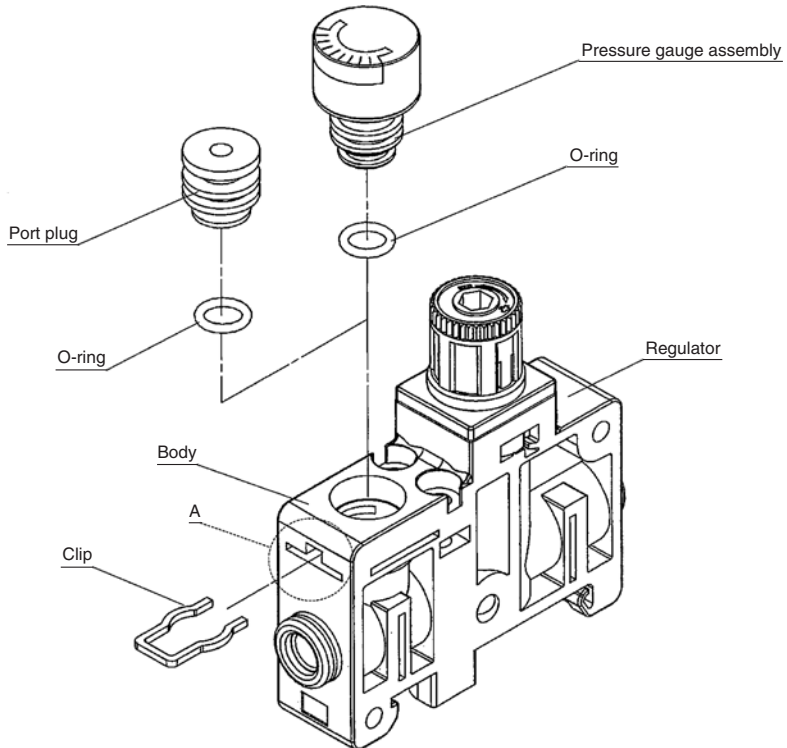

Actuators

Modular F.R.L.
Pressure Control Equipment

Air Preparation
Equipment

Industrial Filters

Replacement
Procedure

Actuators

Modular F.R.L.
Pressure Control Equipment

Industrial Filters

2. Replacement of One-touch Fittings

Content	Exchange of One-touch fittings (IN side and OUT side port)	
Parts	One-touch fittings	
Tools	Watchmakers flat blade screw driver	
Process	Disassembly	Assembly
Procedure	<ol style="list-style-type: none"> 1) Insert a watchmakers flat blade screw driver along with taper of hole B on OUT side of the body. 2) Hook the tip of the screw driver to the inserted clip, and pull out the clip. * As the clip may fly out, pull it slowly as holding it with a hand. 3) Pull out the mounted One-touch fitting. 	<ol style="list-style-type: none"> 1) Insert the One-touch fitting all the way in properly. 2) Put the clip back to the hole. Use the tip of the watchmakers flat blade screw driver to insert the clip to the end properly.
Check item	—	<ol style="list-style-type: none"> 1) Presence of O-ring. (If dust or particles are remained on the O-ring it may cause air leakage. Therefore take measures to prevent them from attaching on the O-ring.)
Exploded view		
	<p>* If it is hard to remove the fitting, do not remove the release bushing with a strong force. It that case, install the tube and plug, and pull the fitting out together with them.</p>	

3. Replacement of Manifold Stations (Common Supply Specification)

Content	Change of manifold stations and common supply block	
Parts	Regulator block, common supply block	
Tools	Phillips head screw driver	
Process	Disassembly	Assembly
Procedure	<ol style="list-style-type: none"> 1) Loosen and remove the cross recessed round head screw on the corner of the end block. 2) Pull out the tie-rod from the end block, common supply block and regulator. 	<ol style="list-style-type: none"> 1) Connect the several tie-rods from each other. 2) Engage the tie-rods with the upper left side of the end block, and temporarily tighten them with 2 pcs. of cross recessed round head screws. 3) Check that O-ring is mounted on the recessed connection of each block of the manifold, and insert the each block to the tie-rods. 4) Temporarily tighten the cross recessed round head screws on the right side. 5) Tighten the cross recessed round head screws on both sides of manifold within the following specified torque.
Check item	—	<ol style="list-style-type: none"> 1) Presence of O-ring. (If dust or particles are remained on the O-ring it may cause air leakage. Therefore take measures to prevent them from attaching on the O-ring.)

Note) The length of tie-rod and common supply tie-rod is varied depending on the applicable stations.
Tie-rods for additional stations, tie-rods for applicable stations or common supply tie-rods are necessary separately.

Exploded view

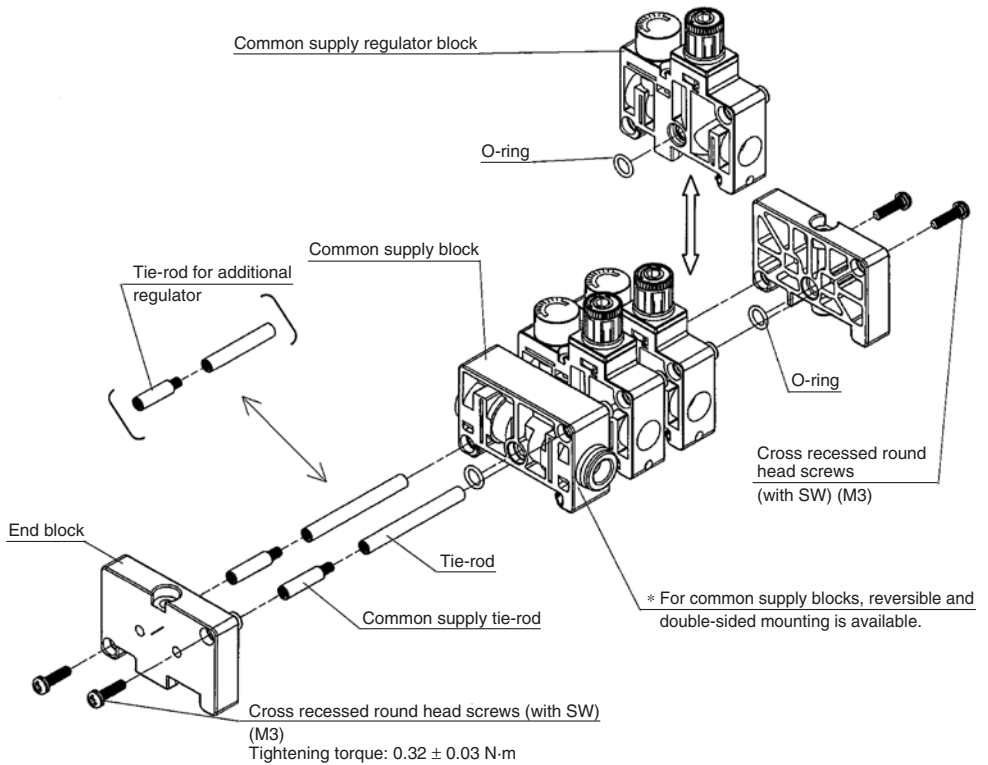

Actuators

Modular FRL
Pressure Control Equipment

Air Preparation
Equipment

Industrial Filters

Replacement
Procedure

Actuators

Modular FRL
Pressure Control Equipment

Industrial Filters

4. Replacement of Manifold Stations (Individual Supply Specification)

Content	Change of manifold stations	
Parts	Regulator block	
Tools	Phillips head screw driver	
Process	Disassembly	Assembly
Procedure	<ol style="list-style-type: none"> 1) Loosen and remove the cross recessed round head screw on the corner of the end block. 2) Pull out the tie-rod from the end block, common supply block and regulator. 	<ol style="list-style-type: none"> 1) Connect the several tie-rods from each other. 2) Engage the tie-rods with the upper left side of the end block, and temporarily tighten them with 2 pcs. of cross recessed round head screws. 3) Insert each block to the tie-rod. 4) Temporarily tighten the cross recessed round head screws (2 pcs.) on the right side. 5) Tighten the cross recessed round head screws on both sides of manifold within the following specified torque.
Check item	—	—

Note) The length of tie-rod and common supply tie-rod is varied depending on the applicable stations.
Tie-rods for additional stations, tie-rods for applicable stations or common supply tie-rods are necessary separately.

Exploded view

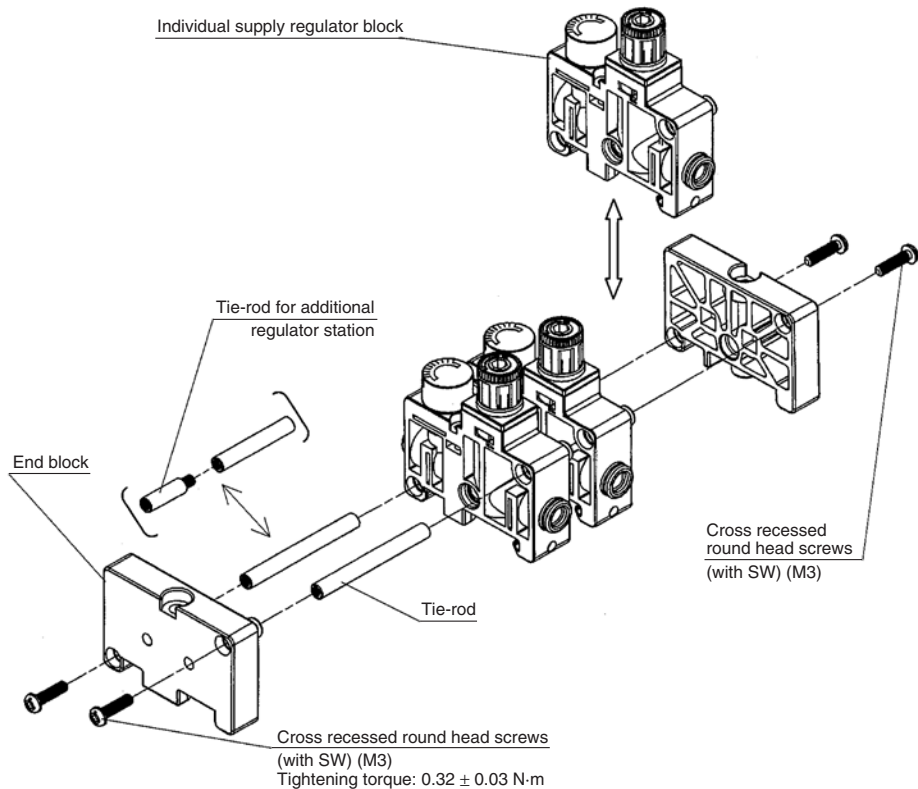

Series ARM10/11A/11B Replacement Procedure of Diaphragm 1

⚠ Warning

Before replacement, ensure that the regulator is not pressurized.
Rotate the pressure adjusting handle counterclockwise fully and to return it to zero. operation.

1. ARM10 Regulator

Content	Wash and replacement of diaphragm, O-ring, valve and valve spring.	
Tools	Spanner (18mm in width), snap ring pliers, tweezers	
Process	Disassembly	Assembly
Procedure	<ol style="list-style-type: none"> 1) Rotate bonnet counterclockwise by holding its width across flats by spanner to disconnect. (Remain pressure adjustment screw and spring mounted on the bonnet.) 2) Remove diaphragm assembly manually. 3) Remove valve seat assembly by holding by snap ring pliers. 4) Remove valve and valve spring. 	<ol style="list-style-type: none"> 1) Mount valve spring and valve by tweezers. 2) Mount valve seat assembly (with two O-rings mounted) by snap ring pliers so that static pressure part of valve seat and OUT passage could be in proper position. 3) Hold the valve seat assembly accessing from side opening to prevent it from coming off. 4) Mount diaphragm assembly. 5) Mount bonnet which has pressure adjustment screw and spring installed to body and rotate it by holding width across flats by spanner clockwise to connect with the body.
Check item	—	<ol style="list-style-type: none"> 1) Presence of O-ring. 2) Position of static pressure part of valves at and OUT passage.
Referential photo	<p>Rotate counterclockwise by holding width across flats by spanner to disconnect.</p>	<p>Rotate clockwise by holding width across flats by spanner to connect.</p> <ol style="list-style-type: none"> 1) Mounted condition of O-ring. 2) Position of static pressure part and OUT passage.

Actuators

Modular F.R.L.
Pressure Control Equipment

Air Preparation
Equipment

Industrial Filters

Replacement
Procedure

Actuators

Modular F.R.L.
Pressure Control Equipment

Industrial Filters

2. ARM11□A/ARM11□C Regulator Block (Handle Position: Top or Bottom Type)

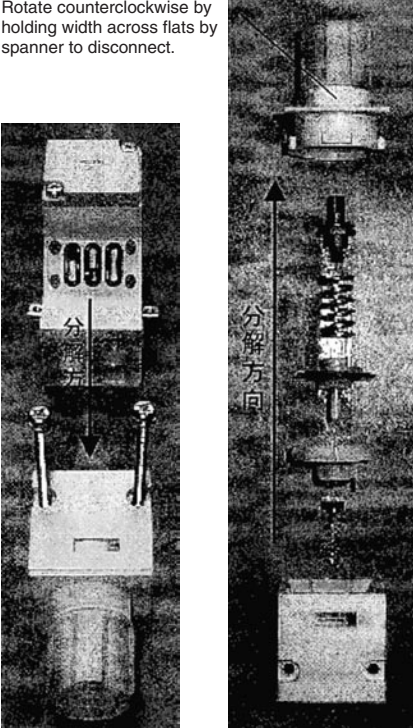
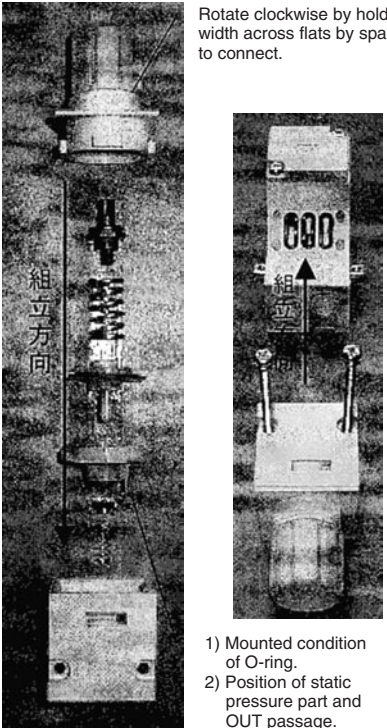
Content	Wash and replacement of gasket, diaphragm, O-ring, valve and valve spring	
Tools	Phillips head screw driver, spanner (18mm in width), snap ring pliers, tweezers	
Process	Disassembly	Assembly
Procedure	<ol style="list-style-type: none"> 1) Loosen and remove round head screws of regulator assembly by Phillips head screw driver to become the regulator assembly able to be disconnected manually. 2) Rotate bonnet counterclockwise by holding its width across flats by spanner to disconnect. (Remain pressure adjustment screw and spring mounted on the bonnet.) 3) Remove diaphragm assembly manually. 4) Remove valve seat assembly by holding by snap ring pliers. 5) Remove valve and valve spring. 	<ol style="list-style-type: none"> 1) Mount valve spring and valve by tweezers. 2) Mount valve seat assembly (with two O-rings mounted) by snap ring pliers so that static pressure part of valve seat and character "A" on body could be in proper position. 3) Hold the valve seat assembly accessing from side opening to prevent it from coming off. 4) Mount diaphragm assembly. 5) Mount bonnet which has pressure adjustment screw and spring installed to body and rotate it by holding spanner flat by spanner clockwise to connect with the body. 6) Mount regulator assembly on manifold block and hold it by tightening two round screws by Phillips driver.
Check item	—	<ol style="list-style-type: none"> 1) Presence of O-ring. 2) Position of static pressure part of valve seat and character "A" on body. 3) Tightening torque of round screw: 0.32 ± 0.03 N-cm
Referential photo	<p>Rotate counterclockwise by holding width across flats by spanner to disconnect.</p> 	<p>Rotate clockwise by holding width across flats by spanner to connect.</p>  <ol style="list-style-type: none"> 1) Mounted condition of O-ring. 2) Position of static pressure part and OUT passage.

3. ARM11□B Regulator Block (Handle Position: Front Type)

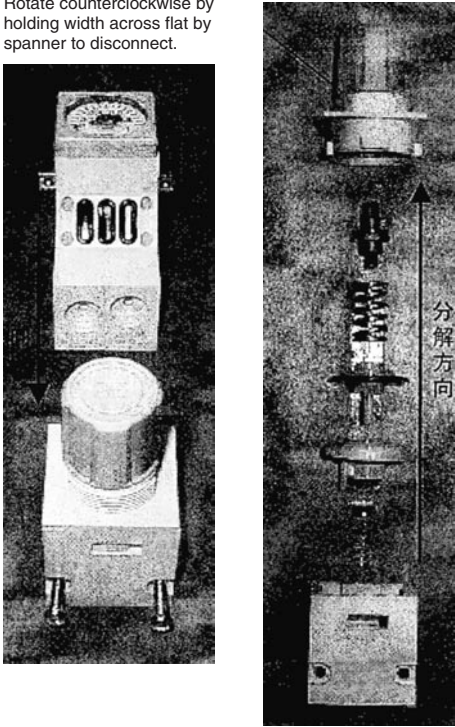
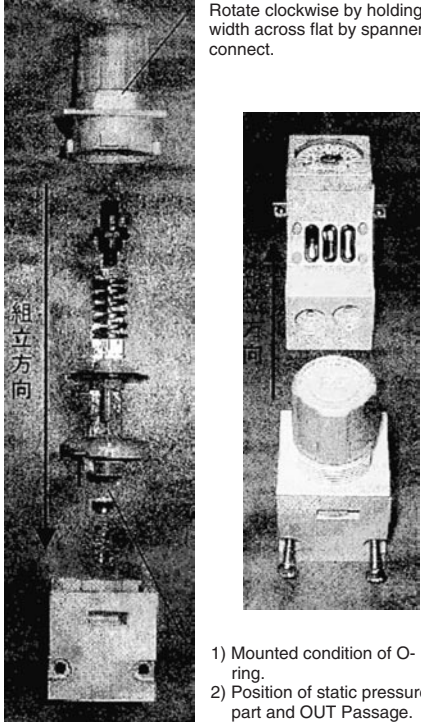
Content	Wash and replacement of gasket, diaphragm, O-ring, valve and valve spring	
Tools	Phillips head screw driver, spanner (18mm in width), snap ring pliers, tweezers	
Process	Disassembly	Assembly
Procedure	<ol style="list-style-type: none"> 1) Loosen and remove round head screws of regulator assembly by Phillips head screw driver to become the regulator assembly able to be disconnected manually. 2) Rotate bonnet counterclockwise by holding its width across flat by spanner to disconnect. (Remain pressure adjustment screw and spring mounted on the bonnet.) 3) Remove diaphragm assembly manually. 4) Remove valve seat assembly by holding by snap ring pliers. 5) Remove valve and valve spring. 	<ol style="list-style-type: none"> 1) Mount valve spring and valve by tweezers. 2) Mount valve seat assembly (with two O-rings mounted) by snap ring pliers so that static pressure part of valve seat and character "B" on body could be in proper position. 3) Hold the valve seat assembly accessing from side opening to prevent it from coming off. 4) Mount diaphragm assembly. 5) Mount bonnet which has pressure adjustment screw and spring installed to body and rotate it by holding spanner flat by spanner clockwise to connect with the body. 6) Mount regulator assembly on manifold block and hold it by tightening two round screws by Phillips head screw driver.
Check item	—	<ol style="list-style-type: none"> 1) Presence of O-ring. 2) Position of static pressure part of valve seat and character "B" on body. 3) Tightening torque of round head screw: 0.32 ± 0.03 N-cm
Referential photo	<p>Rotate counterclockwise by holding width across flat by spanner to disconnect.</p> 	<p>Rotate clockwise by holding width across flat by spanner to connect.</p>  <ol style="list-style-type: none"> 1) Mounted condition of O-ring. 2) Position of static pressure part and OUT Passage.

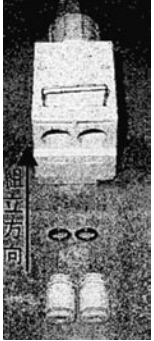

4. ARM10, 11 Regulator, Manifold Block

Content	Wash, air blowing and replacement of O-ring of fittings	
Tools	Watchmakers flat blade screw driver	
Process	Disassembly	Assembly
Procedure	<ol style="list-style-type: none"> 1) Remove clip with held by watchmakers flat blade screw driver. 2) Pull fitting assembly out manually. 	<ol style="list-style-type: none"> 1) Push fitting assembly until it comes to a stop to mount. 2) Push clip until it comes to a stop to mount.
Check item	—	<ol style="list-style-type: none"> 1) Confirmation that the fitting assembly reaches mounting end for it. 2) Confirmation that the clip reaches mounting end for it.
Referential photo		

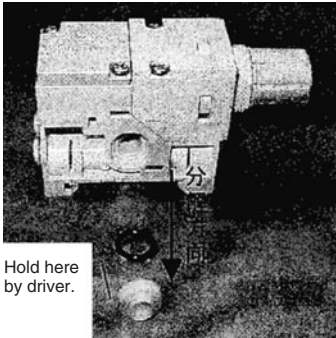
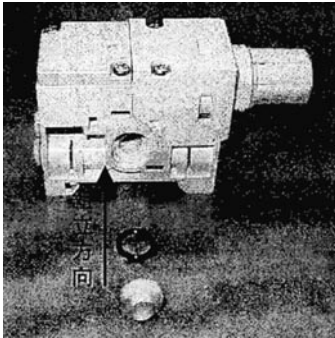

5. ARM11 Regulator Block

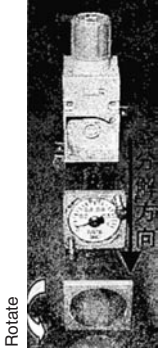
Content	Wash and replacement of O-ring of bushing	
Tools	Watchmakers flat blade screw driver	
Process	Disassembly	Assembly
Procedure	<ol style="list-style-type: none"> 1) Remove bushing with held by watchmakers flat blade screw driver. 2) Remove O-ring from the bushing. 	<ol style="list-style-type: none"> 1) Mount O-ring to bushing. 2) Push the bushing until it comes to a stop to mount.
Check item	—	1) Confirmation that the bushing reaches mounting end for it.
Referential photo	 <p>Hold here by driver.</p>	

6. ARM10, ARM10F Regulator

Content	Wash and replacement of O-ring of pressure gauge	
Tools	Phillips head screw driver	
Process	Disassembly	Assembly
Procedure	<ol style="list-style-type: none"> 1) Remove cover assembly by rotating counterclockwise manually. 2) Loosen and remove two round head screw by Phillips head screw driver. 3) Remove pressure gauge assembly. 4) Remove O-ring. 	<ol style="list-style-type: none"> 1) Mount O-ring. 2) Mount pressure gauge assembly. 3) Hold the pressure gauge assembly by tightening two round head screws by Phillips head screw driver. 4) Mount cover assembly by rotating clockwise manually. (Mind direction of cover and position of locating mark and detent.)
Check item	—	<ol style="list-style-type: none"> 1) Presence of O-ring 2) Tightening torque of round head screw: 0.32 ± 0.03 N·cm
Referential photo		

7. ARM11 Regulator Block

Content	Wash and replacement of O-ring of pressure gauge	
Tools	Phillips head screw driver	
Process	Disassembly	Assembly
Procedure	<ol style="list-style-type: none"> 1) Loosen and remove round head screws from regulator assembly by Phillips head screw driver to becomes the regulator assembly able to be disconnected. 2) Remove cover assembly by rotating counterclockwise manually. 3) Remove two round head screws from pressure assembly by Phillips head screw driver. 4) Remove pressure gauge assembly. 5) Remove O-ring. 	<ol style="list-style-type: none"> 1) Mount O-ring to bush. 2) Mount pressure gauge assembly. 3) Hold the pressure gauge assembly by tightening two round head screws by Phillips head screw driver. 4) Mount cover assembly by rotating clockwise manually. (Mind direction of cover and position of locating mark and detent.) 5) Mount regulator assembly to manifold block and hold it by tightening two round screws by
Check item	—	<ol style="list-style-type: none"> 1) Presence of O-ring 2) Tightening torque of round head screw: 0.32 ± 0.03 N·cm
Referential photo		

Industrial Filters Replacement Procedure

FGD	Vessel Series	P.460
FGE	Vessel Series	P.461
FGET	Vessel Series	P.463
FGG	Vessel Series	P.466
FGA	Vessel Series	P.468
FGB	Vessel Series	P.472
FGC	Vessel Series	P.476
FGF	Bag Filter	P.478
FGH	High Precision Filter for Liquids	P.480
FQ1	Filter for Cleaning Fluid/Quick Change Filter	P.482
FN1-FN4	Low Maintenance Filter	P.483

Actuators

Modular F.R.L.
Pressure Control Equipment

Air Preparation
Equipment

Industrial Filters

Replacement
Procedure

Actuators

Modular F.R.L.
Pressure Control Equipment

Industrial Filters

1. Installation

- 1-1. Connect the piping after confirming IN and OUT.
- 1-2. Use clean pipes for piping.
- 1-3. The seal tapes should not come off.
- 1-4. Hold the filter cover with a spanner when connecting the tubes for piping to the filter.
Never hold the filter case when piping.
- 1-5. Secure the space (not less than 50mm) under the filter so that the element can be taken out.

2. Removal of the Element

- 2-1. Stop the fluid from flowing into the filter.
- 2-2. Loosen the hexagon head bolt (air ventilation) to release the internal pressure of the filter completely.
- 2-3. Remove the plug to discharge the drainage from the filter.
- 2-4. Loosen the nut to remove the case.
The case can be removed by lowering it for approximately 50mm.
- 2-5. Remove the element from the case.
* For the filter that uses 2 elements (L250), be careful not to loose the guide used for sealing between the elements because it is re-used.
- 2-6. Wash and clean inside the case, the gasket, the packing and the plug with clean fluid or solvent.
* Do not take the tension bolt away from the case.

3. Mounting of the Element

- 3-1. Replace the defective gasket and packing with new ones if there any of them are defective.
- 3-2. Put the tension bolt through the hole of the element, and insert the element into the case.
* For the filter that uses 2 elements, insert the guide between the elements.
- 3-3. Align the tension bolt to the center hole of the cover, and insert the case that has the element inside into the cover.
- 3-4. Press the casing from the bottom, and tighten the nut from the top of the cover.
- 3-5. Confirm that it has no fluid leakage after the test operation before starting the actual operation.

Series *FGE* Replacement Procedure of Element 1

1. Removal of the Cover

- 1-1. Stop operation
- 1-2. Close the valve in order of INLET, then, OUTLET.
- 1-3. Zeroes the pressure in the filter.
- 1-4. Open the drain valve for inlet and outlet to discharge all fluid inside.
- 1-5. Pull out the V-band clamping position check pin.
- 1-6. Loosen V-band tightening nut and remove the latch. Then, remove the cover and O-ring for checking,
- 1-7. Rotate the cover counterclockwise and lift it to remove the cover. (In order of (1)(2) in drawing on the right)
- 1-8. If O-ring is swollen, replace it with a new O-ring.

O-ring for replacement Part no.: JISB2401-1A-P185 (NBR)
Part no.: JISB2401-4D-P185 (FKM)

⚠ Warning

Remove V-band/cover after confirming the pressure in the filter is zero.

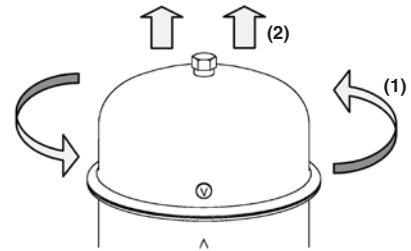
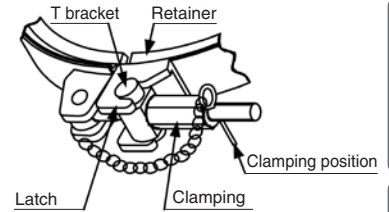

2. Removal of the Element

- 2-1. Remove the wing nut and the washer.
- 2-2. Remove the element retainer.
- 2-3. Remove the element mounting bracket (a part integrating the element holder and the spring).
- 2-4. Take out parts in order of the element, joint (element guide).
* It is not a must to take out the element guide.
Element, and joint can be taken out together by taking out the element guide.
(Note) Joint may not be necessary depending on filter and element type.

⚠ Caution

Attention should be taken to avoid burning for high temperature.

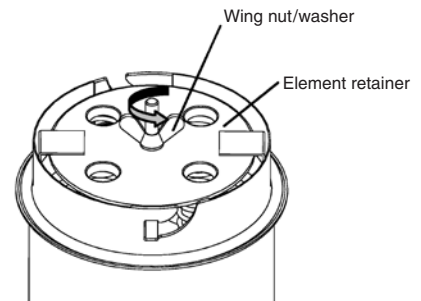

3. Mounting of the Element

- 3-1. To recycle the micro mesh element and sintered element, eliminate any dust between the end plate and the seal completely.

⚠ Caution

Replace all equipment using fluoropolymer seal. Recycle of used seal leads to cause sealing leakage.

- 3-2. Mount the element guide if it is removed.
- 3-3. Insert parts in order of the element, joint, element, then, element mounting bracket so that they are concentric.
(Note) Joint may not be necessary.

⚠ Caution

When element is mounted, do not drop the parts from the top of the element guide for mounting.

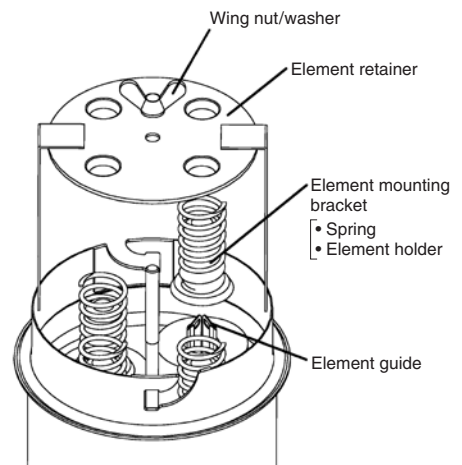

Actuators

Modular F.R.L.
Pressure Control Equipment

Air Preparation
Equipment

Industrial Filters

Replacement
Procedure

Actuators

Modular F.R.L.
Pressure Control Equipment

Industrial Filters

Series FGE Replacement Procedure of Element 2

- 3-4. When 2 to 3 elements are placed on top of the other, a set in which the element and joint are prepared can be mounted to the element support.
- 3-5. Assemble the element mounting bracket.
- 3-6. Mount the element retainer carefully.

4. Mounting of O-ring and Cover

- 4-1. Set O-ring to the case
- 4-2. Rotate the cover clockwise while pushing till the end so that the orientation mark of the case and the cover match. [In order of (1) and (2) on drawing on the right]

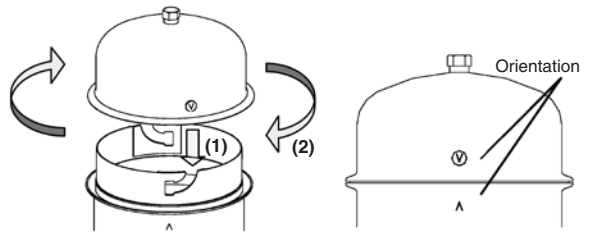

5. Mounting and Tightening V-band

- 5-1. Mount V-band to the collar of the cover and the case correctly. [Refer Fig. (a), (b)]

⚠ Warning

The cover may be fallen off due to incorrect mounting. Mount the cover properly.

- 5-2. Hit the circumference of V-band lightly with plastic hammer for secure mounting.
- 5-3. Mount T-bracket to the latch correctly. [See Fig. (c)]
- 5-4. Tighten the clamping nut to specified position (position from where clamping position check pin can be inserted), and insert the clamping position check pin. [See Fig.(c)]
- 5-5. When clamping nut can not be tightened to specified position(position where clamping position check pin can be inserted), replace V-band and O-ring to new ones. (See table 1).

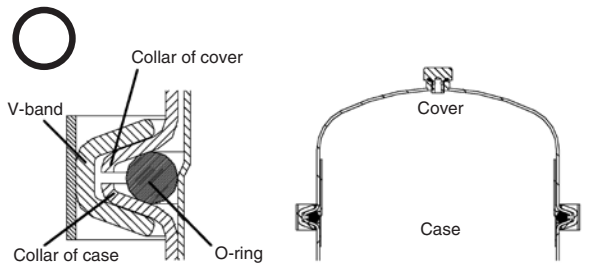

Fig. (a) Correct mounting of V-band

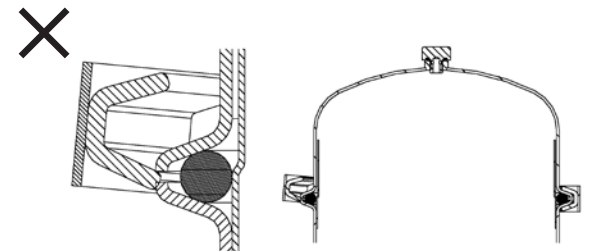

Fig. (b) Incorrect mounting of V-band
(Not correctly with collar of cover)

⚠ Caution

Clean V-band and the contact surface between the cover and the case before mounting. Dirty contact surface lead to cause leakage.

⚠ Warning

Replace with a new V-band when deformation or worn out by screw is found on the band.

[V-band for replacement] Part no. : CY-24S

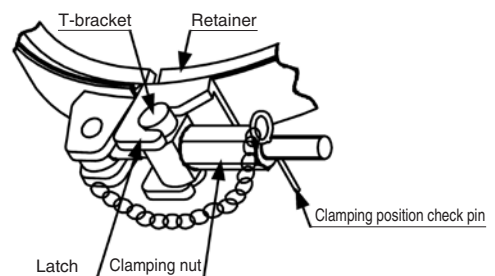
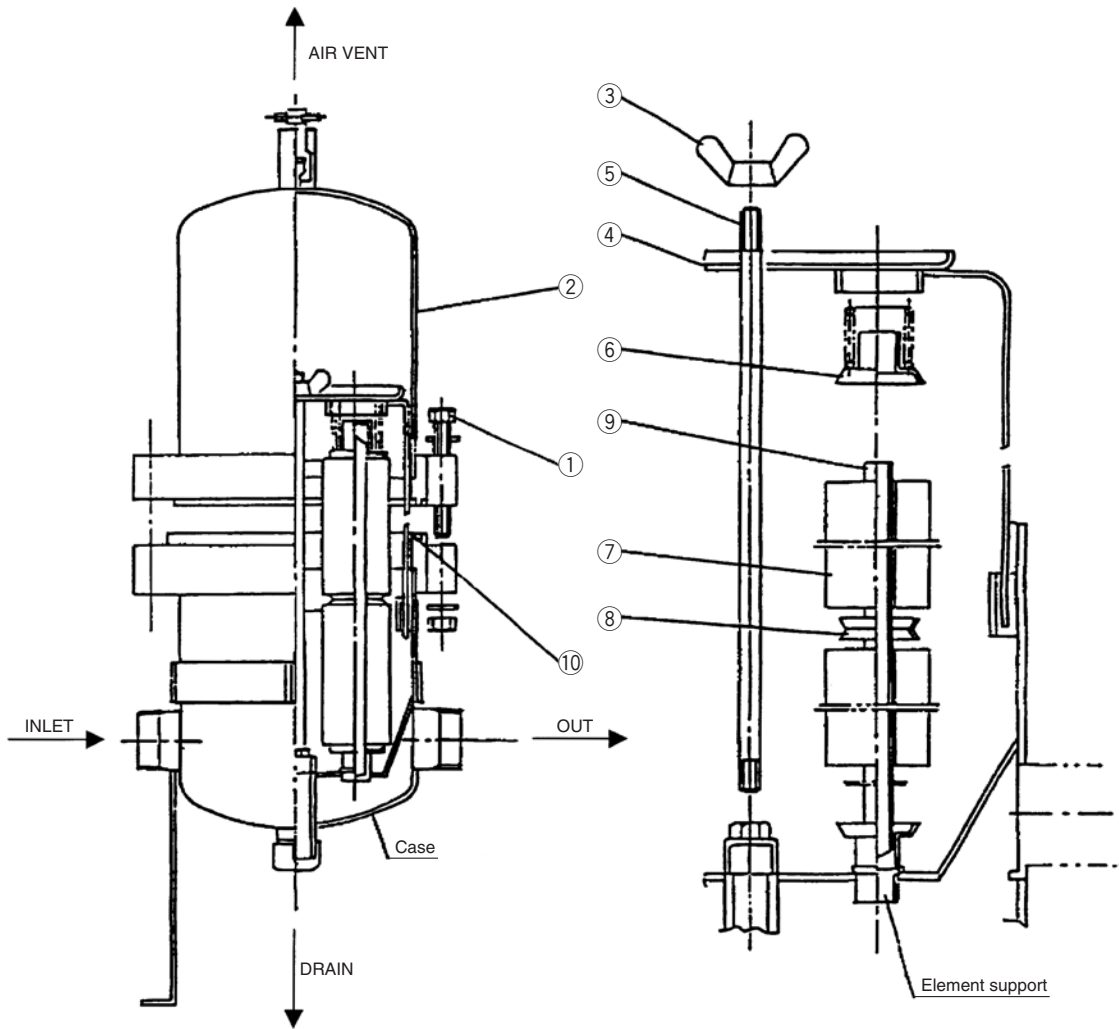

Fig. (c) V-band tightening

6. Restart and Air Discharge

- 6-1. When restart the operation after the replacement of the element, mount V-band to specified position. Confirm connecting parts and seal do not leak before start operation.
- 6-2. When restart the operation, open the upper air relief port to **discharge air**.

1. Instruction Drawing for Disassembly & Reassembly of Filter



- | | |
|----------------------------------|----------------------------|
| ① Hexagon head bolt, nut, washer | ⑥ Element mounting bracket |
| ② Cover | ⑦ Element |
| ③ Wing nut | ⑧ Joint |
| ④ Element retainer | ⑨ Element guide |
| ⑤ Tension bolt | ⑩ O-ring |

2. Removal of the Cover

- 2-1. Close the inlet and outlet valves.
- 2-2. Open the drain valve to make the pressure in the filter zero, and open the air vent valve to completely remove the inside fluid.
- 2-3. Loosen the hexagon head bolts and nuts fastening the filter cover to the filter case.
- 2-4. Remove the cover.

3. Removal of the Element

- 3-1. Remove the wing nut.
- 3-2. Remove the element retainer.
- 3-3. Take out parts in order of the element mounting bracket, element, joint, and element guide. The element guide may not necessarily be taken out. It is not a must to take out the element guide.

After removal of the element mounting bracket, the elements and joints can be taken out as a unit by taking out the element guide in accordance with instructions shown in Fig. 1.

Note) Joint may not be necessary.

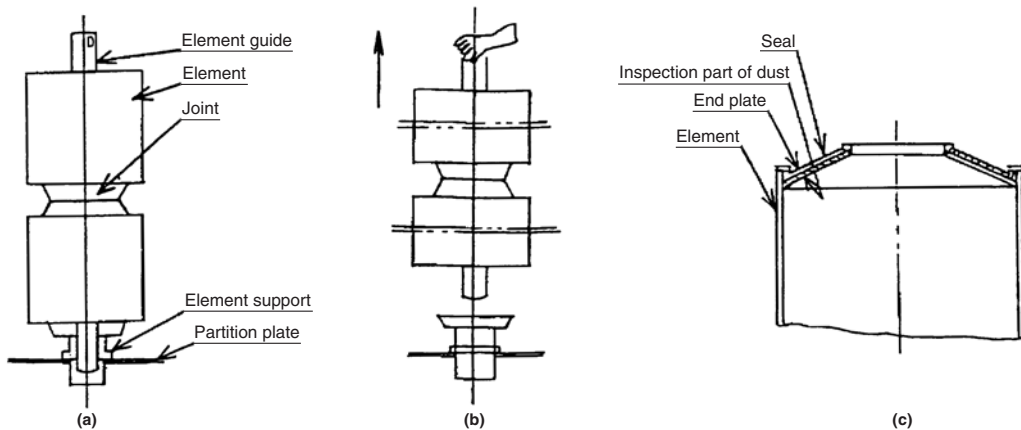

Fig. 1

4. Cleaning of the Element

- 4-1. Immerse any taken-out element in a cleaning liquid such as trichlene, carbon tetrachloride, volatile oils for 10 to 15 min.
- 4-2. Clean it in trichlene liquid with ultrasonic vibration. If ultrasonic cleaning is impossible, wash them in the following way:
- 4-3. Take out the element from the cleaning liquid and clean the inside and out side of the element thoroughly with a brush (preferably a soft brush such as brass brush.)
- 4-4. Reimmerse the element in the liquid and remove dirty substances on the inside of the element by agitating the liquid.
- 4-5. Take out the element and blow compressed air into the inside of the element to make the dirty substances in the inside come out to the surface.
- 4-6. Brush the element in the cleaning liquid to take away dirty substances on its surface.
- 4-7. Repeat the following (4-4) till the element is free from dirty substances on its surface.
- 4-8. Take out the element and blow compressed air into the inside.
- 4-9. Immerse the element in clean water and agitate the water.
- 4-10. Take out the element from the water and blow compressed air into the inside of the element to blow off moisture therein. Then dry it.

Note 1) Cleaning liquids should be handled in a well ventilated and fire-free place.

Note 2) Use plastic or rubber gloves to prevent the skin from coming into direct contact with washing liquid.

Note 3) Should a loaded element not be normalized by repeated cleaning, send it back to the manufacturer for cleaning.

5. Mounting of the Element

(Handle the elements in a clean atmosphere.)

5-1. For fitting a cylindrical or pleat type micromesh element (which does not use spherical seal) or a sintered element, remove dust between the end plate and the seal completely without fail, before fitting. (Refer to Fig. 1 c)

Note) Replace any Teflon seal if used.

It should be kept in mind that the reuse of Teflon seal can result in poor sealing because of its hardness.

5-2. Mount the element guide if taken off.

5-3. Insert an element, joint, the other element, and element mounting bracket in this order and in such a way that they are exactly concentric.

Note) Some units may not require the joint, does not need according to circumstances.

In incorporating the element to the element guide, do not drop the element from the upper end of the element guide.

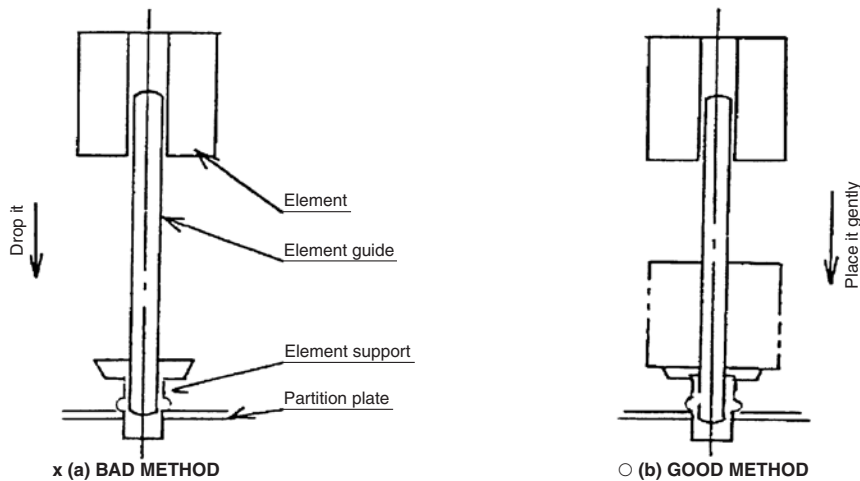

Note) When 2 or 3 elements are put one upon another, it is possible to firstly set elements and joints to the element guide and then mount the element guide assembly on the element support. (Refer to Fig. 1, reversely to the order of removal.)

5-4. Incorporate the element mounting bracket.

5-5. Fit the element retainer gently.

6. Mounting of the Cover

6-1. After making sure that the gasket is not damage, set it at the given place.

Damaged gasket requires replacement.

6-2. Set the cover at the given place.

6-3. Fasten the hexagon head bolts, nuts and washer.

7. Restart and Air Discharge

Make sure that no pressure-leak is exhibited from the seat surface. Then put the unit into regular operation in accordance with the procedure of operation described below.

7-1. Before starting the operation, make sure of the open or close position of each valve in the piping and of being perfectly sealed at the joining parts.

7-2. Open the air discharging valve and supply fluid. Upon air in the container is removed completely, close the air discharging valve. Then start a regular operation.

Note) Since this filter consists of many thin press-formed parts, it must be handled using clean gloves.

Series *FGG* Replacement Procedure of Element 1

1. Removal of the Cover

- 1-1. Stop operation.
- 1-2. Close the valve in order of INLET, then, OUTLET.
- 1-3. Zeroes the pressure in the filter.
- 1-4. Open the drain valve for inlet and outlet to discharge all fluid inside.
- 1-5. Pull out the V-band clamping position check pin.
- 1-6. Loosen V-band tightening nut and remove the latch. Then, remove the cover and O-ring for checking,
- 1-7. Rotate the cover counterclockwise and lift it to remove the cover. [In order of (1)(2) in drawing on the right]
- 1-8. If O-ring is swollen, replace it with a new O-ring.

O-ring for replacement Part no.: AL-25S (NBR)
Part no.: AL-22S (FKM)

⚠ Warning

Remove V-band/cover after confirming the pressure in the filter is zero.

2. Removal of the Element

- 2-1. Remove the wing nut and the washer.

⚠ Caution

Please remove two wing nuts at the same time. The element retainer might not be able to incline from one side when it is outside and to remove well.

- 2-2. Remove the element retainer.
 - 2-3. Remove the element mounting bracket (a part integrating the element holder and the spring).
 - 2-4. Take out parts in order of the element, then, joint (element guide).
 - * It is not a must to take out the element guide.
 - Element, and joint can be taken out together by taking out the element guide.
- Note) Joint may not be necessary depending on filter and element type.

⚠ Caution

Attention should be taken to avoid burning for high temperature.

3. Mounting of the Element

- 3-1. To recycle the micro mesh element and sintered element, eliminate any dust between the end plate and the seal completely.
 - 3-2. Mount the element guide if it is removed.
 - 3-3. Insert parts in order of the element, joint, element, then, element mounting bracket so that they are concentric.
- Note) Joint may not be necessary.

⚠ Caution

When element is mounted, do not drop the parts from the upper end of the element guide for mounting.

- 3-4. When 2 to 3 elements are placed on top of the other, a set in which the element and joint are prepared can be mounted to the element support.
- 3-5. Assemble the element mounting bracket.
- 3-6. Mount the element retainer carefully.

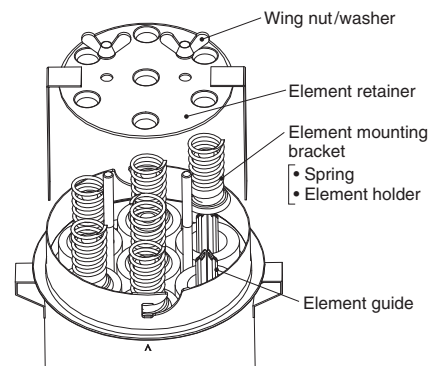
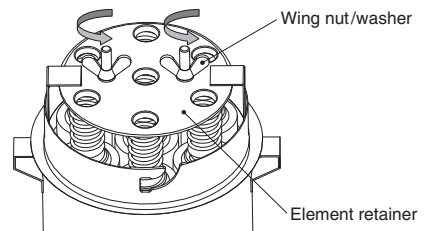
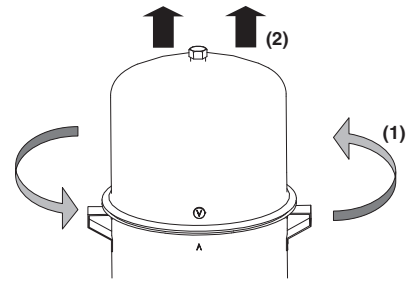
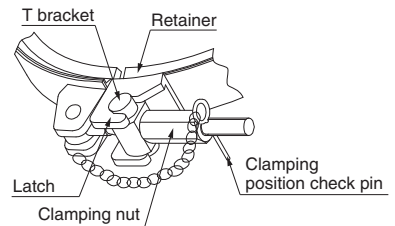

4. Mounting of O-ring and Cover

- 4-1. Set O-ring to the case.
- 4-2. Rotate the cover clockwise while pushing till the end so that the orientation mark of the case and the cover match. [In order of (1) and (2) on drawing on the right]

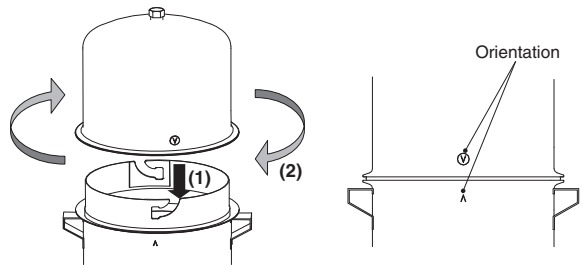

5. Mounting and Tightening of V-band

- 5-1. Mount V-band to the collar of the cover and the case correctly. [Refer Fig. (a), (b)]

⚠ Warning

The cover may be fallen off due to incorrect mounting. Mount the cover properly.

- 5-2. Hit the circumference of V-band lightly with plastic hammer for secure mounting.
- 5-3. Mount T-bracket to the latch correctly. [See Fig. (c)]
- 5-4. Tighten the clamping nut to specified position (position from where clamping position check pin can be inserted), and insert the clamping position check pin. [See Fig. (c)]
- 5-5. When clamping nut can not be tightened to specified position (position where clamping position check pin can be inserted), replace V band and O-ring to new ones. (See table 1).

⚠ Warning

Replace with a new V-band when deformation or worn out by screw is found on the band

[V-band for replacement] Part no: CY-27S

⚠ Caution

Clean V-band and the contact surface between the cover and the case before mounting. Dirty contact surface lead to cause leakage.

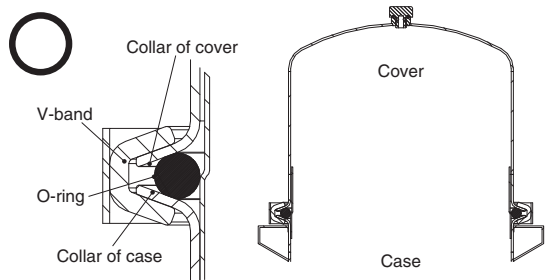

Fig. (a) Correct mounting of V-band

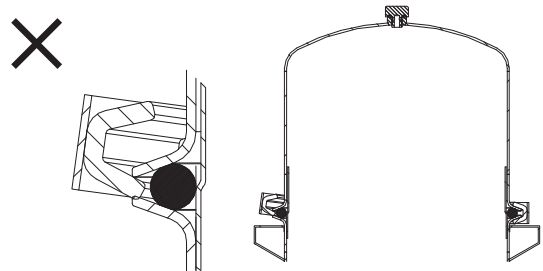

Fig. (b) Incorrect mounting of V-band

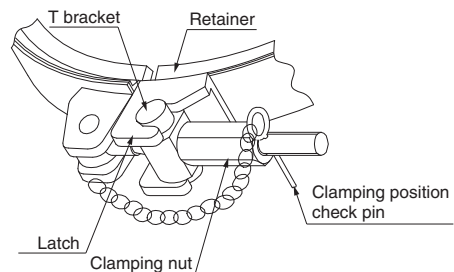
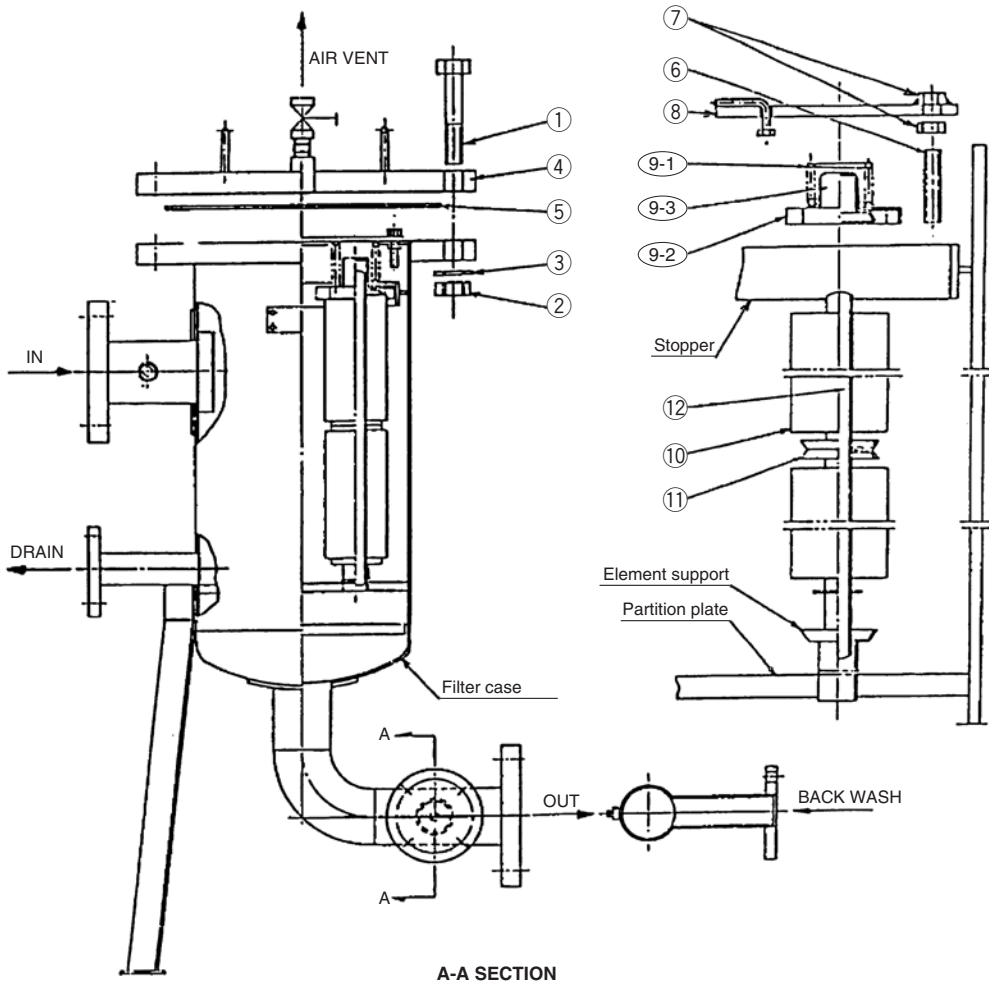

Fig. (c) V-band tightening

6. Restart and Air Discharge

- 6-1. When restart the operation after the replacement of the element, follow the procedure of section 4 "Operation".
- 6-2. When restart the operation, open the upper air relief port to **discharge air**.

1. Instruction Drawing for Disassembly & Reassembly of Filter



- ① Hexagon head bolt
- ② Hexagon nut
- ③ Washer
- ④ Cover
- ⑤ Gasket

- ⑥ Adjustment bolt
- ⑦ Lock nut
- ⑧ Element retainer
- ⑨ Element mounting bracket
- ⑨-1 Spring

- ⑨-2 Vibration stop
- ⑨-3 Element holder
- ⑩ Element
- ⑪ Joint
- ⑫ Element guide

2. Overhaul

- 2-1. If the differential pressure rises due to clogging and reaches the threshold for element replacement (0.1 MPa), replace the element with the new one.
- 2-2. The removal and mounting of the element at the time of overhauling shall be made in the following sequence.

4. Removal of the Element

- 4-1. Remove the element retainer.
Set the bolt and nut of ⑥ and ⑦ in the plate as it is.
Please note that it could cause deformation due to the incomplete sealing or overtightened element if it is mounted without any adjustment. For details, refer to section 7, "Adjustment Method for Mounting Other Elements".
- 4-2. Take them out in the element mounting bracket, element, joint, element guide in order.
The element guide is not required to be taken out forcibly.
After the element holder is taken out, if the element guide is taken out in such a manner as shown in Fig. 1, the element and joint can be taken out together.
(Note) In some cases, no joint is required.

3. Removal of the Cover

- 3-1. Close the valves at inlet and outlet.
- 3-2. Open the air vent and drain valves and make the pressure inside the filter zero (0) in order to discharge all fluid inside.
- 3-3. Loosen the bolt and nut of ① and ② for tightening the filter cover and filter case meanly little by little.
When the nut can be turned with hand, remove them one after another in order from the end.
- 3-4. Remove the cover and gasket.

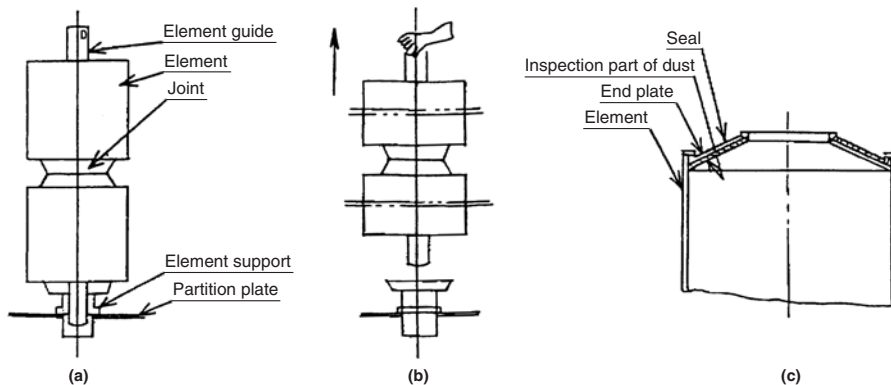

Fig. 1

5. Mounting of the Element

- (Be sure to handle at clean surrounding condition)
- 5-1. In the case of micro mesh element (cylindrical or pleat type (spherical seal is not used)) and sintered element, be sure to remove dust completely between end plate and seal completely. (Refer to Fig. 1 (c))
(Note) When Teflon seal is used, be sure to exchange it for new one.
As it is hard, as the seal becomes imperfect, attention must be paid to it.
 - 5-2. Mount the element guide if taken off.
 - 5-3. Insert them in the order of element, joint, element, element mounting bracket in order in such a way that they are concentric.
In some cases, no joint is required.
(Note) When the element is mounted, be sure to avoid building in it by dropping from the upper end of the element guide.

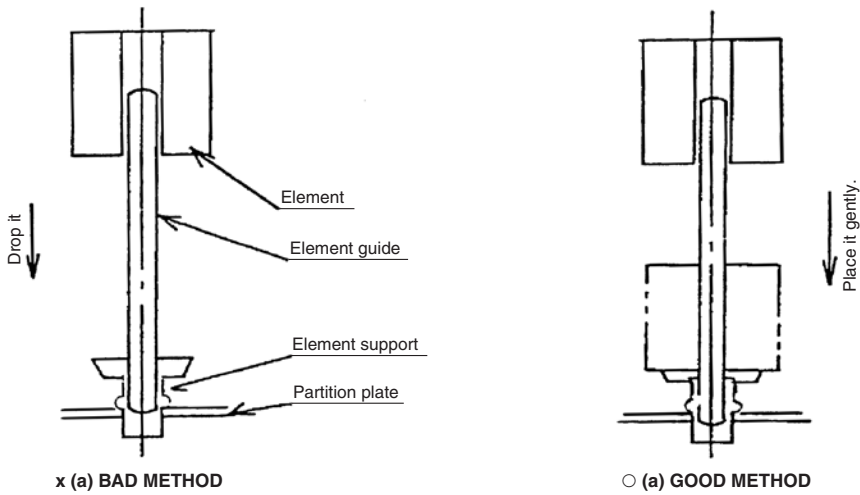
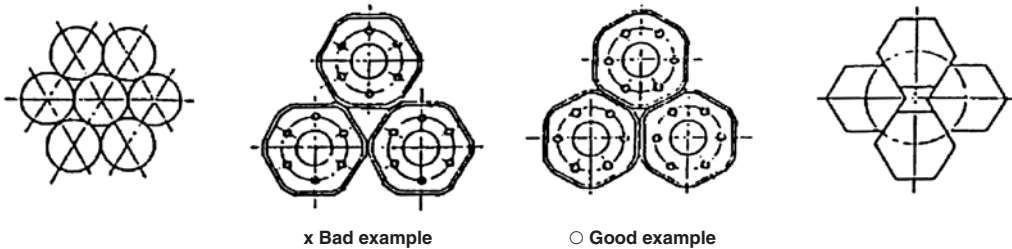

Fig. 2

* Incidentally, when the number of arrangements is many and the number of piling of elements is 3-4 stages, the one in which element and joint are set in the element guide can be set at element support. [Refer to Fig. 1 for the details: Procedure opposite to that for removal]

5-4. The element mounting bracket must be built in it by such a manner as shown in (b) and (c) of (Fig. 3).



(a) Arranging condition of element.

(b) Arrangement of more 7 pcs.

(c) 4-pcs. arrangement

Fig. 3

Note) Fig. 3 (b) and (c) show the arranging condition of the element mounting bracket (spring, vibration stop, element holder) shown in Fig. 4

5-5. Fit the element retainer gently.

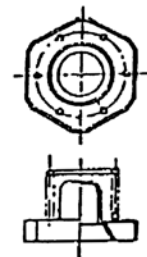

Fig. 4

6. Mounting of the Cover

6-1. After confirmation that there is no damage in the gasket, set it at specified position and set the bolts of ① ② and ③, washer, nut and tighten it uniformly diagonally.

When the gasket is damaged, exchange it for new one.

6-2. After confirmation that there is no leakage of pressure from the seat surface, start the normal operation.

(Method of operation, please refer to the instruction manual.)

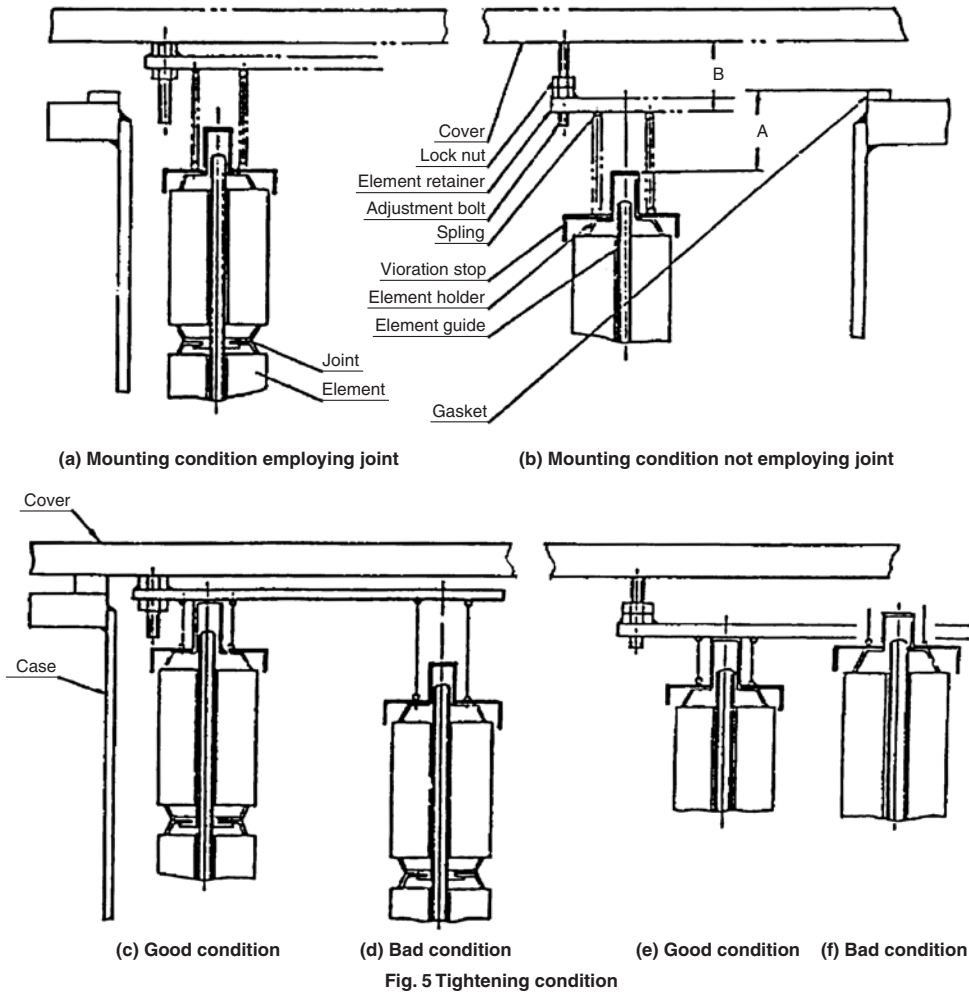

7. Adjustment Method for Mounting Other Elements

7-1. Adjust it in such a way that the element retainer and element are at close contact condition when the filter cover is installed, employing the adjustment bolt and lock nut shown in (Fig. 5) [Refer to (c) and (e) of Fig. 5] when the element retainer is installed.

7-2. Adjustment must be made in the following manner.

Make measurement on dimensions A as shown in Fig. 5 (b) and adjust it in such a way that Dimensions A are equal to those B, resulting in being at such a condition as shown in (e) of Fig. 5.

As can be seen in Fig. 5 (a) and (b), the lock nut should be set to the bottom in the installation employing the joint. In the installation not employing the joint, set it to the top.

1. Instruction Drawing for Disassembly & Reassembly of Filter

Element assembly exploded view

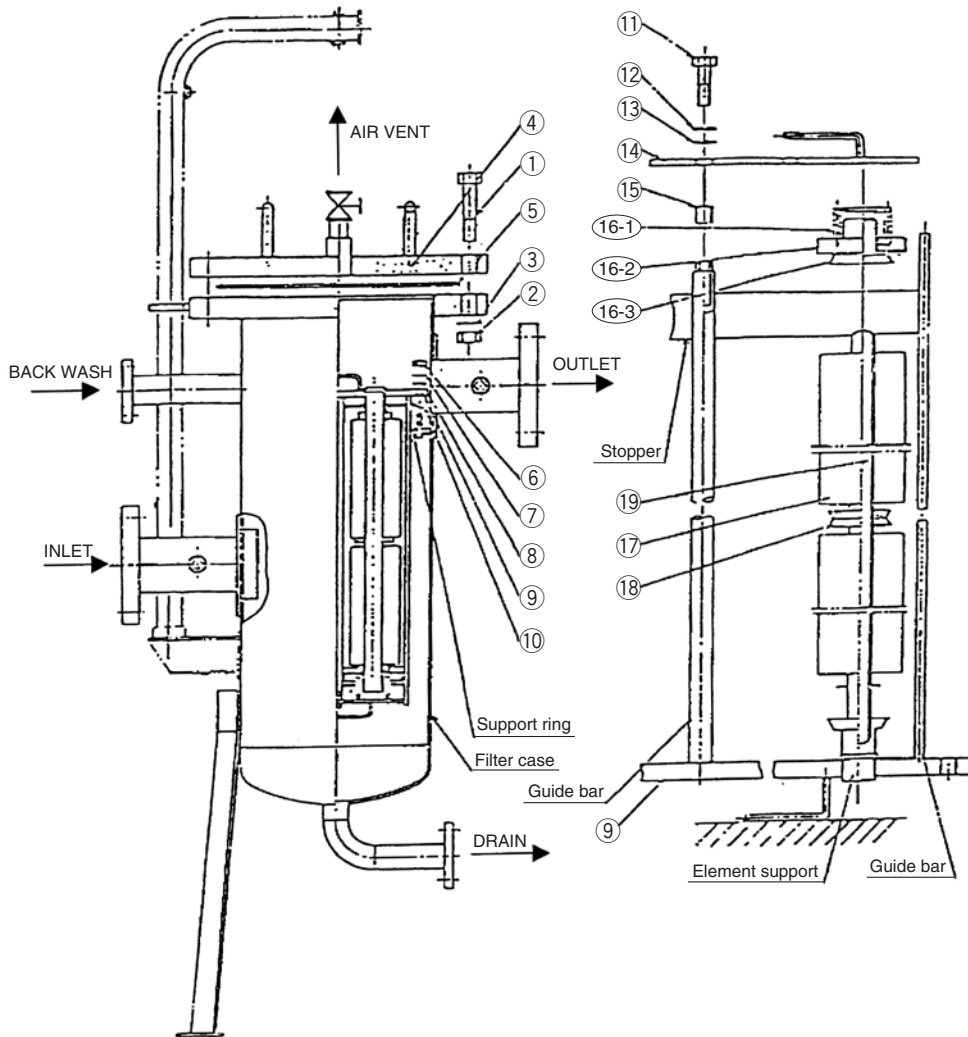

- ① Hexagon head bolt
- ② Hexagon nut
- ③ Washer
- ④ Cover
- ⑤ Gasket
- ⑥ Hexagon nut
- ⑦ Spring washer
- ⑧ Washer

- ⑨ Partition-plate
- ⑩ Gasket
- ⑪ Hexagon head bolt
- ⑫ Spring washer
- ⑬ Washer
- ⑭ Element retainer
- ⑮ Collar
- ⑯ Element mounting bracket

- ⑰ Spring
- ⑱ Vibration stop
- ⑲ Element holder
- ⑳ Element
- ㉑ Joint
- ㉒ Element guide

2. Overhaul

- 2-1. If the differential pressure rises due to clogging and reaches the threshold for element replacement (0.1 MPa), replace the element with the new one.
- 2-2. The removal and mounting of the element at the time of overhauling shall be made in the following sequence.

3. Removal of the Cover

- 3-1. Close the valves at inlet and outlet.
- 3-2. Open the air vent and drain valves and make the pressure inside the filter zero (0) in order to discharge all fluid inside.
- 3-3. Loosen the bolt ①, nut ②, the filter cover and filter case uniformly little by little.
When the nut can be turned with hand, remove them one after in order the end.
- 3-4. Remove the cover and gasket.

5. Removal of the Element

- 5-1. Loosen the hexagon head bolt of ① uniformly little by little.
Remove the spring washer and washer.
- 5-2. Remove the element retainer.
- 5-3. Take out the members in the order of collar, element mounting bracket, element, joint and element guide.
The element guide is not needed to be taken out forcibly. If the element guide is taken out in the procedure after taking out of the element holder (Fig. 1 (b)), both element and joint can be taken out at the same time.
Note) Joint is not needed in some cases.

4. Method for Removal of Element Assembly

- 4-1. Loosen the nut ⑥ little by little uniformly.
Remove the nut, spring washer and washer.
- 4-2. Lift the element assembly from the container by means of a dabit or any other lifting device out of the container.
Then, lift it vertically so that the guide bar protecting the element does not touch the support ring too much.
- 4-3. Turn the element assembly taken out of the container upside down so that the partition plate is located downwards as illustrated in the disassembly drawing.

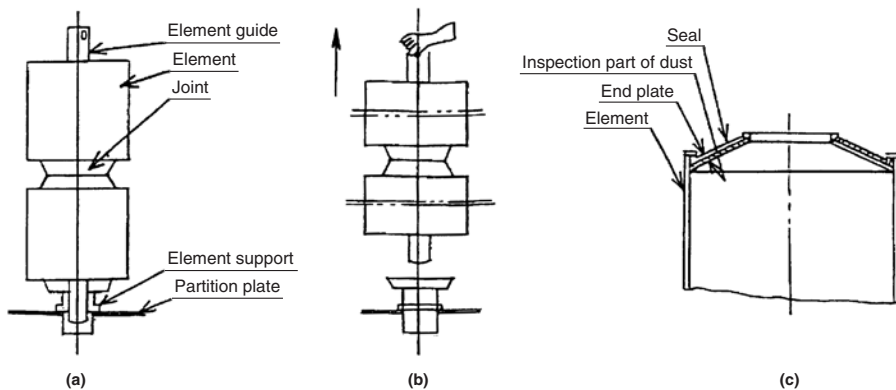

Fig. 1

6. Mounting of the Element

(Be sure to handle it in the clean environmental condition.)

6-1. In the case of micromesh element (cylindrical and pleat type (employing no seal)) and sintered element, be sure to remove the dust located between end plate and seal without fail. (Refer to Fig. 1 (c) for the details)

6-2. When the element guide is removed, fit it.

6-3. Insert the members correctly in the order of element, joint, element and element fitting hardware in such a way that concentricity may be obtained.

Note) No joint is needed sometimes.

When the element is installed, do not drop it from the upper end of the element guide and assemble it. (Fig. 2)

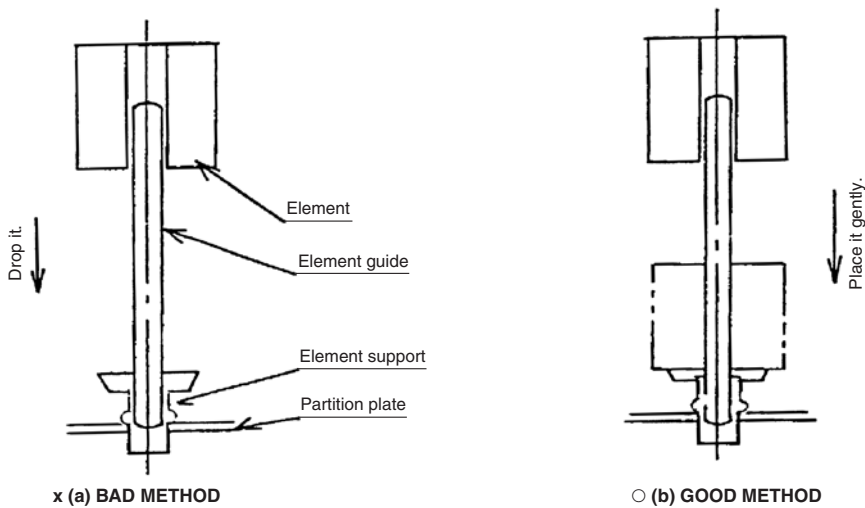

Fig. 2

Note) When the number of arranged ones is many and the number of stacking of elements is 3-4 stages, the element guide to which the element and joint are set can be set to the element support. (Refer to Fig. 1 for the details: Opposite procedure to that for taking out)

6-4. The fitting hardware for element shall be assembled in such a method as shown by (b) and (c) of (Fig. 3).

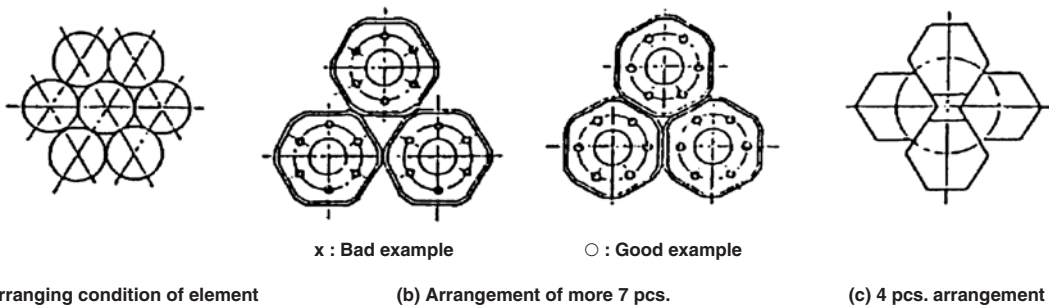

Fig. 3

Note) Fig. 3 (b) and (c) show the arranging condition of the element mounting bracket in Fig. 4 (spring, vibration stop, element holder).

Series *FGB* Replacement Procedure of Element 4

6-5. The collar should be set to the bottom of the element retainer only when the honeycomb element is used. For other elements, it should be set to the top of the retainer.

Note 1) The collar is not used for single element assembly.

Note 2) The collar for honeycomb element cannot be used for other elements.

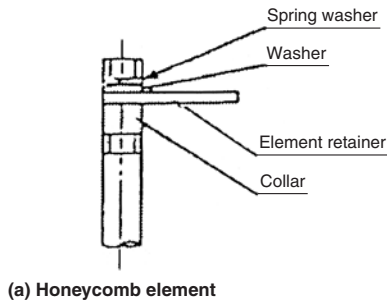

(a) Honeycomb element

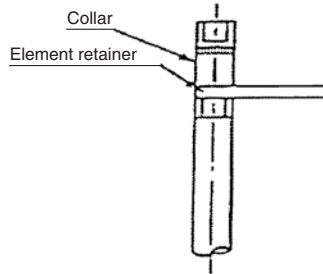

(b) Other elements
(Sintered, paper, micromesh)

Fig. 5

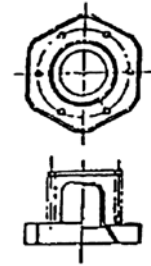
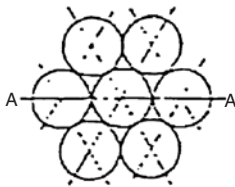
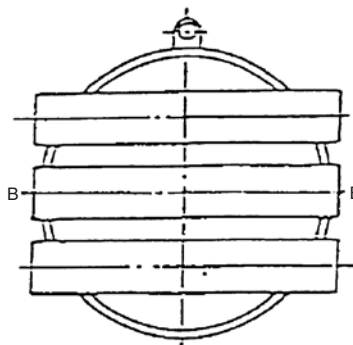

Fig. 4

6-6. The element retainer shall be assembled in such a way that the symbol A-A in (a) of Fig. 6 is overlapped with symbol B-B of element retainer shown in (b) of Fig. 6 in parallel.



(A) Arranging condition of element



(b) Element retainer

View of "c"

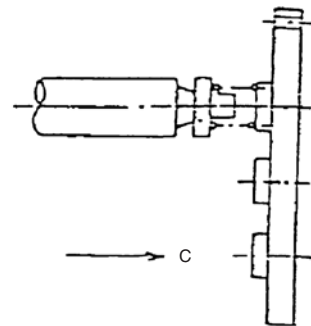

Fig. 6

Note 1) When the element retainer is installed, place it correctly in such a way that the element mounting bracket is not moved.

Note 2) Fit the washer of ⑬ ⑫ and spring washer and tighten the bolt of ⑪ uniformly little by little. Then, tighten it to such an extent that the guide bar comes in close contact with bolt nut, spring washer, washer, element retainer.

7. Mounting of the Element Assembly

7-1. Turn the element assembly set at 4-2-4 upside down in such a way that the partition plate comes upside.

7-2. Before the element assembly is installed, be sure to install the gasket at specified position correctly.

7-3. Employing the dabit and other lifting devices, assemble it in the same way that the element assembly is taken out.

7-4. Install the washer of ⑧ and ⑦ and spring washer and tighten it uniformly with nut of ⑥.

8. Mounting of the Cover

8-1. Ensure that the gasket is not damaged, and set it to the specified position. Also set the bolts ①②③, washer and nut, and tighten it evenly from the opposing corners.

If the gasket is damaged, replace it with the new one.

8-2. After ensuring that there is no pressure leakage, start the actual operation.

Series *FGC* Replacement Procedure of Element ①

1. Instruction Drawing for Disassembly & Reassembly of Filter

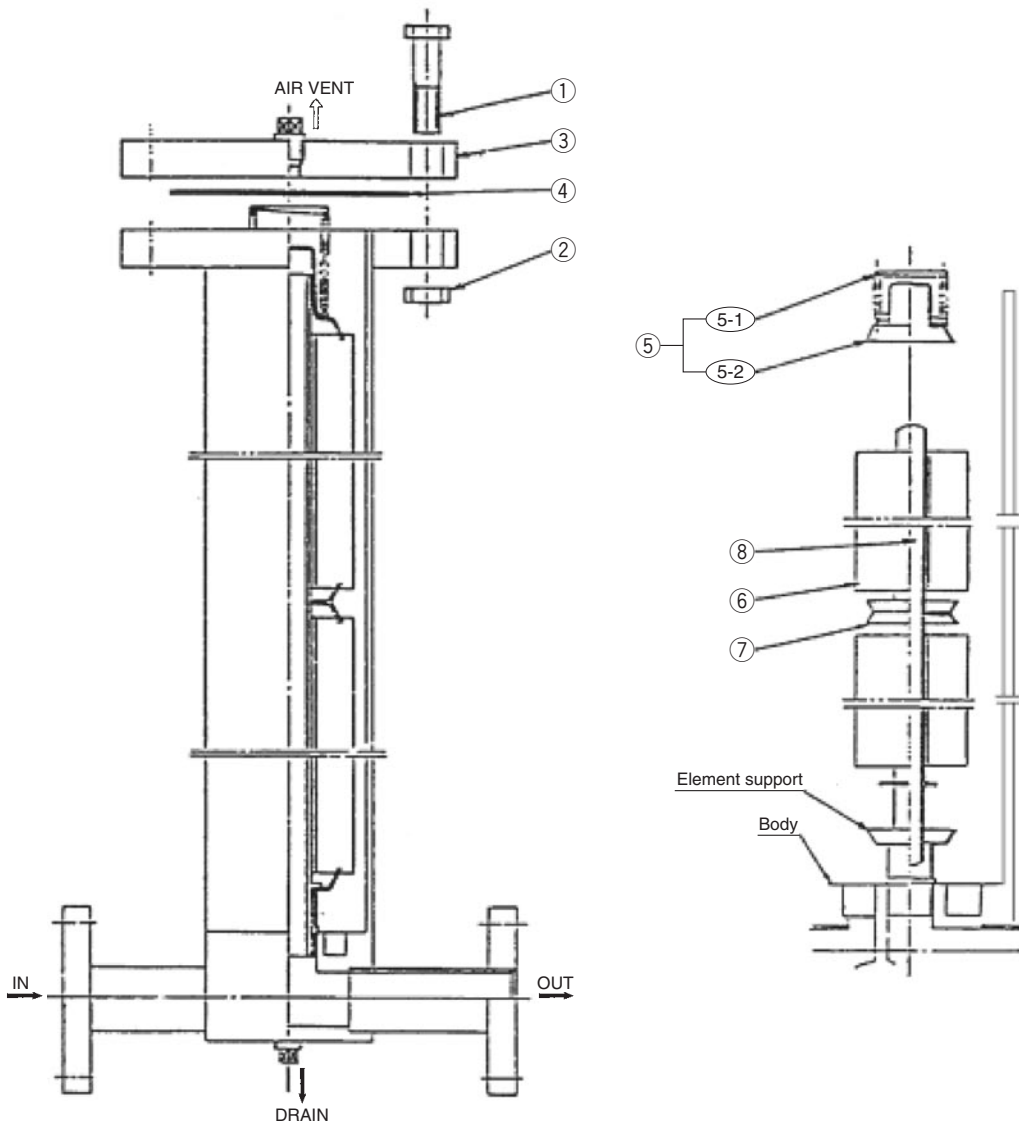

- | | | |
|---------------------|----------------------------|-----------------|
| ① Hexagon head Bolt | ⑤ Element mounting bracket | ⑦ Joint |
| ② Hexagon Nut | ⑤-1 Spring | ⑧ Element guide |
| ③ Cover | ⑤-2 Element holder | |
| ④ Gasket | ⑥ Element | |

2. Overhaul

- 2-1. If the differential pressure rises due to clogging and reaches the threshold for element replacement (0.1 MPa), replace the element with the new one.
- 2-2. Take out the element at the time of overhauling and carry out the mounting operation in the following sequence.

3. Removal of the Cover

- 3-1. Close the valves at inlet and outlet.
- 3-2. Open the air vent valve and drain valve in order make the pressure inside the filter zero (0) and discharge all fluid from the inside.
- 3-3. Loosen the bolt and nut ① and ② for tightening of the filter cover and filter case little by little meanly at first. When the nut can be turned with hand, remove them one after another in order from the end.
- 3-4. Remove the cover and gasket.

4. Removal of the Element

- 4-1. Take out the element mounting bracket, element, joint, element guide in order.
- 4-2. It is not required to take out the element forcibly.
- 4-3. After taking out the element holder, the element and joint can be taken out together if the element guide is taken out in such a manner as mentioned in (Fig.1).

Note) In some cases, no joint is required.

5. Mounting of the Element (Handle it at clean surrounding condition)

- 5-1. As for the elements except the honeycomb and paper elements, check if there is no dust between the end plate and seal when taking them out. If there is any dust, clean it off. (See Fig. 1 (c).)
- 5-2. Mount it when the element guide is removed:
- 5-3. Insert them in the order of element, joint, element, element mounting bracket in such a way that they are concentric.

Note) No joint is needed in some cases.

When the element is installed, avoid building in it by dropping from the upper end of the element guide when the element is installed.

6. Mounting of the Cover

- 6-1. After confirmation that there is no damage in the gasket, set it at specified position and set the bolt and nut ① and ② and tighten it uniformly diagonally.
When the gasket is damaged, exchange it for new one.
- 6-2. After confirmation that there is no leakage of pressure from the seat surface, start operation.

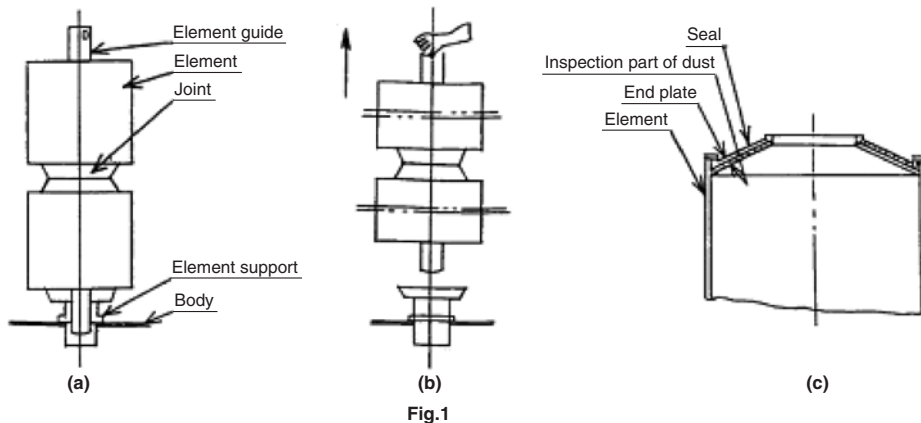

Fig.1

Series FGF Replacement Procedure of Element 1

One element included type

1. Removal of the Element

- 1-1. After stopping the operation, close the valve in the order of inlet and outlet.
- 1-2. Open the air release valve to let the internal pressure of a filter be zero, and open the liquid discharging valve to let out the internal fluid completely.

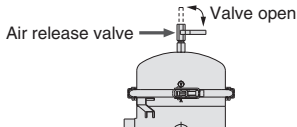

- 1-3. Loosen the tightening bolts of the V-band and remove the stopper.
(The tightening bolts can be loosened with a hexagon wrench [width across flats 6 mm].)

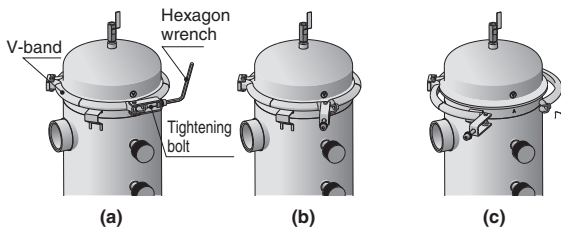

- * Check the O-ring and the V-band, and if there is any abnormality, replace it with a new one.
(Refer to "Replacement Parts" on page 268.)

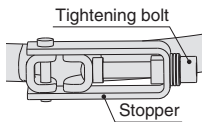

- 1-4. Remove the cover upward by turning it counterclockwise.

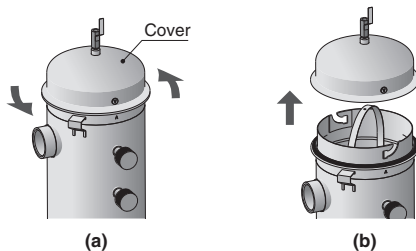

- 1-5. Using the handle, remove the basket vertically.
* Inspect the O-ring attached to the holder assembly in the case, and replace it with a new one if it is expanded or there is any abnormality.
(Refer to "Replacement Parts" on page 268.)

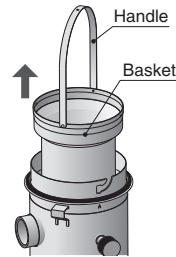

- 1-6. A handle made of cloth is attached to the element so that elements can be pulled out of the basket by fingers or using sticks, pulling them to the center.
(Element for replacement: Refer to "Part number of element for replacement" on page 268.)

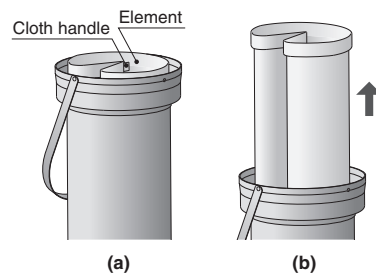

2. Mounting of the Element

- 2-1. Pull a new element by the cloth handle toward the center, and put it inside the basket, folding the edge of an element. Further, push the edge of an element to the basket's bottom-plate flange surface thoroughly.

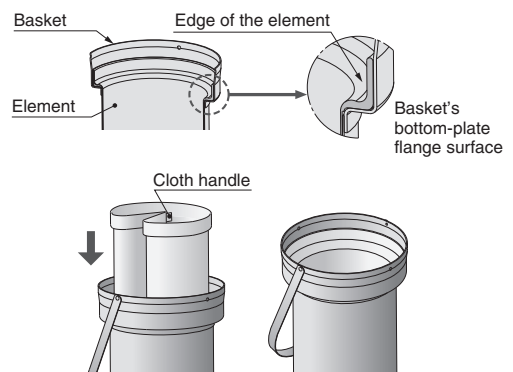

- * Set the handle avoiding attaching it to the notch (guide slit) of the case and INLET.

Series FGF Replacement Procedure of Element 2

2-2. Grasp the handle and put the basket in the case.

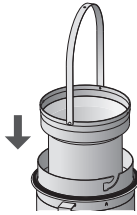

2-3. Set the O-ring to the case.

* Replace the O-ring with a new one if it is expanded or there is any abnormality. (Refer to "Replacement Parts" on page 268.)

2-4. Adjust the pins (two locations) to the guide slit of the case inside the cover, and push them thoroughly and turning clockwise.

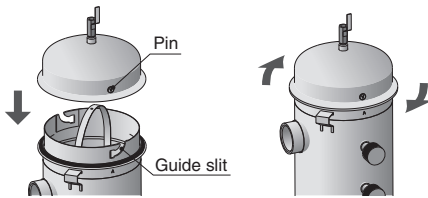

2-5. Install the V-band in the edge of the cover and case correctly.

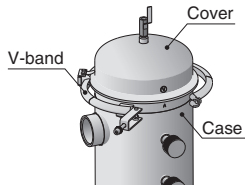

* Clean the contact surface of the V-band, cover and case prior to the attachment.

2-6. Align the tightening bolts with the slit and fasten properly.

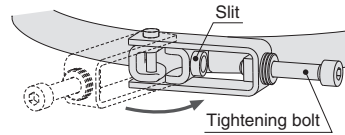

2-7. Tighten the tightening bolts until they cohere to the flat washers.

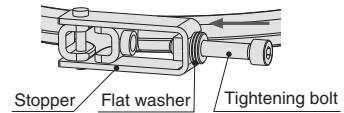

* When restarting this product after replacing the elements, be sure to release the air by opening the release valve on the top.

Actuators

Modular F.R.L.
Pressure Control Equipment

Air Preparation
Equipment

Industrial Filters

Replacement
Procedure

Actuators

Modular F.R.L.
Pressure Control Equipment

Industrial Filters

Series *FGH* Replacement Procedure of Element 1

1. Instruction Drawing for Disassembly & Reassembly of Filter

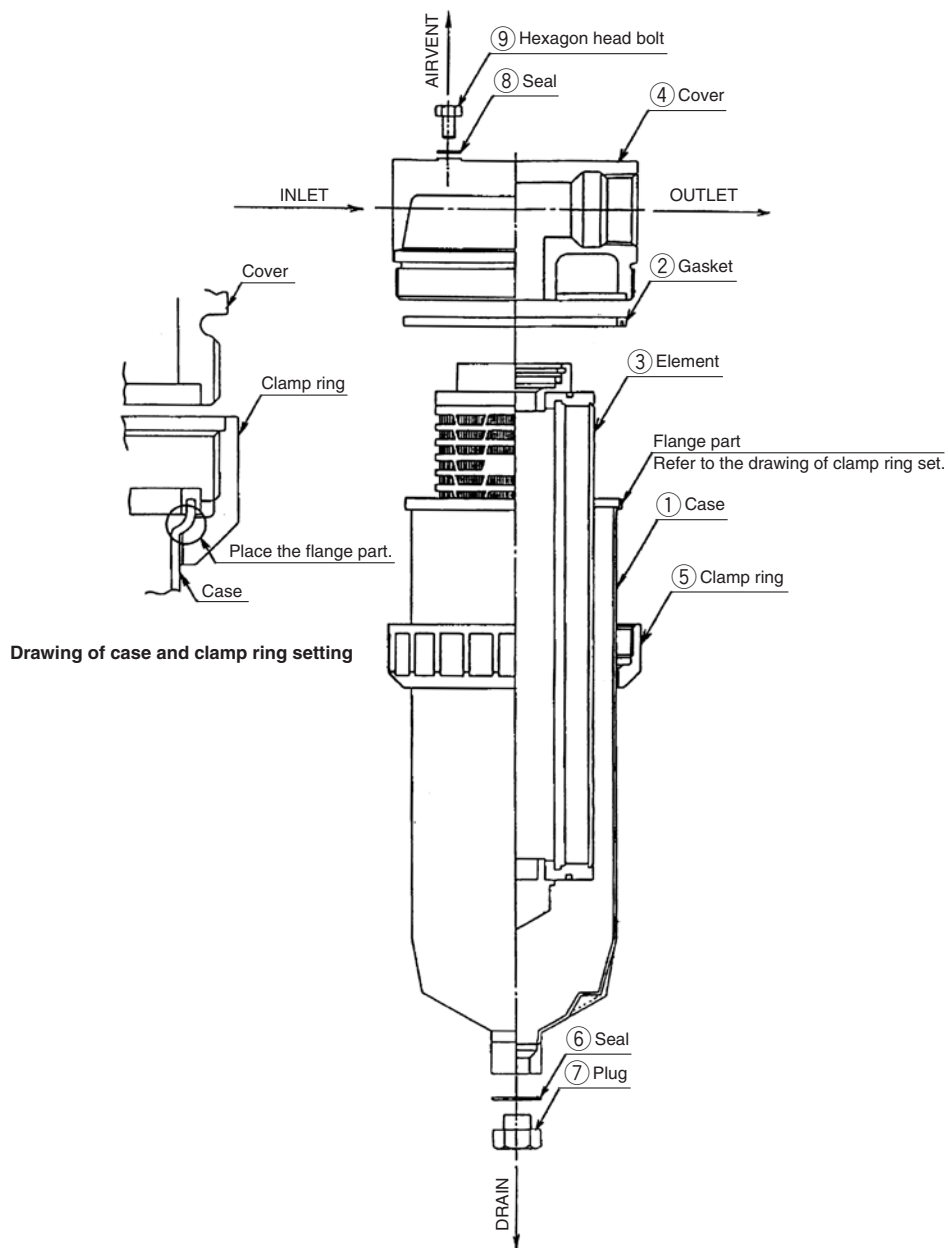

Series *FGH* Replacement Procedure of Element ②

1. Removal of the Element

- 1-1. Stop the fluid sent to the filter. (If a valve is installed before or after the filter, close the valve.)
- 1-2. Loosen the air vent (hexagon head bolt ⑨) and completely discharge the pressure in the filter.
- 1-3. Remove drain (plug ⑦) and discharge the fluid from the filter.
- 1-4. A large force is required to loosen clamp ring ⑤. Use a commercially available belt wrench etc. to loosen clamp ring ⑤ so that the tool is not removed, so as to make it turnable by hand. Remove case ① by hand while supporting it, and remove the element together with case ①.
- 1-5. Pull out element ③ from cover ④. Since the PTFE seal is used, a certain amount of force may be necessary to pull out the element. If there is not enough space under case ①, lower case ① by about 100mm, and remove the element together with case ①.
- 1-6. Dispose the removed element.
- 1-7. Clean the inside of case, ①, gasket ②, seal ⑥ and plug ⑦ using clean operation fluid or solvent.

2. Mounting of new Element

- 2-1. Check that the sealing surface of case ① is not scarred.
- 2-2. Check whether or not the gasket and seal are damaged or deformed.
Replace any abnormal one with a new one.
- 2-3. Since the PTFE seal is used for element ③, a certain amount of force is needed to set the element. Set the element in the following procedure. Handle element ③ carefully to keep it clean, for example, open the element package only when the element is mounted.
 - a. Fit the grooved part of gasket ② into the flange part of case ①.
 - b. Place element ③ in case ①. Element ③ must be positioned at the center of case ①.
 - c. Set clamp ring ⑤ to case ①. The tapered part of clamp ring ⑤ must be facing downward.
 - d. Set seal part of the element ③ to the cover ④ while the flange part of case ① is being placed on clamp ring ⑤.
 - e. Since PTFE is used for the material of gasket ②, a large force is required to tighten clamp ring ⑤. After screwing clamp ring ⑤ into cover ④ by hand, use a commercially available belt wrench etc. to tighten the clamp ring so that the tool is not removed and no leakage occurs. (Reference tightening rotation angle: approx. 1/4 to 1/2 turn after tightening by hand)
* This makes the element ③ be pushed up as a whole, and the element seal will be installed to the case ① sealing. The element ③ can also be pushed hard by hand to be surely installed before setting the case ①.
- 2-4. Set seal ⑥ on plug ⑦ of drain and tighten hexagon head bolt ⑨ of the air vent so that no leakage occurs.
- 2-5. Start the operation.

Actuators

Modular F.R.L.
Pressure Control Equipment

Air Preparation
Equipment

Industrial Filters

Replacement
Procedure

Actuators

Modular F.R.L.
Pressure Control Equipment

Industrial Filters

Series **FQ1** Replacement Procedure of Element 1

1. Removal of the Element

- 1-1. Stop liquid flowing into the filter. (If there are valves before and after the filter, close these valves.)
- 1-2. Release pressure inside the filter completely by loosening the air vent plug.
- 1-3. Discharge fluid inside the filter by removing the drain plug.
- 1-4. Remove the stopper from the retainer by loosening the wing bolt on the V-band.

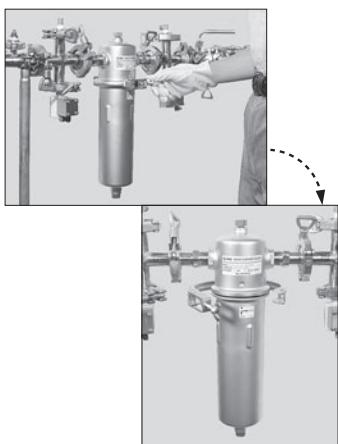

- 1-5. To extract the element from the case, rotate the case counterclockwise about 20 degrees until it stops, then lower it by about 40 mm and remove it from the cover.

Note) When two L250 elements are used, do not discard the intermediate holder and lower element holder attached under the element, since they are reused.

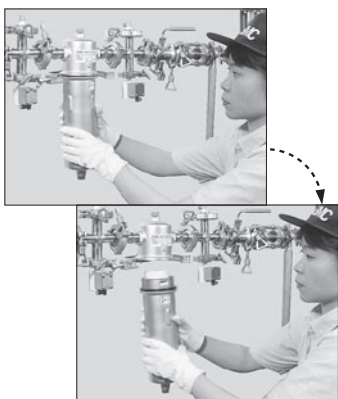

- 1-6. Clean the inside of the case, gaskets, seals, holders, plugs, etc., with a pure fluid or solvent.

2. Installing the Element

- 2-1. Make sure that O-rings are not damaged or deformed. If needed, replace with new ones.
- 2-2. Set the lower element holder under the element, and place them in the case.
[When using two L250 elements]
Insert the intermediate holder into the lower part of the second element (upper level), and then place them into the case after inserting one side of the intermediate holder into the upper part of the element that is attached to the lower holder.

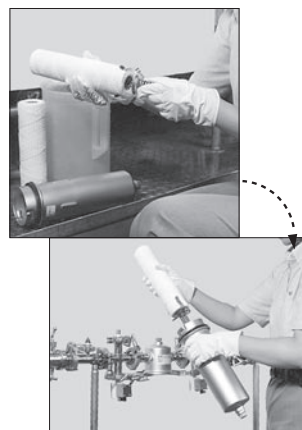

- 2-3. Align the indentations of the case with the projections of the cover, lift the case upward by about 10 mm and rotate it clockwise about 20 degrees.
- 2-4. Mount it in such a way that the entire flanged perimeter of the cover and case are held by the retainer of the V-band.

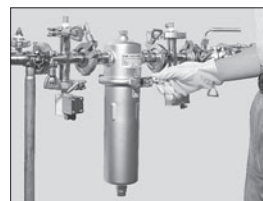

- 2-5. Set the stopper on the retainer while holding down the V-band outside perimeter, and then tighten the wing bolt to the prescribed position.
- 2-6. Tighten the drain plug.
- 2-7. When air release is completed, tighten the air vent plug.

Series FN1/FN4 Replacement Procedure of Element 1

1. Instruction Drawing for Disassembly & Reassembly of Cover Assembly

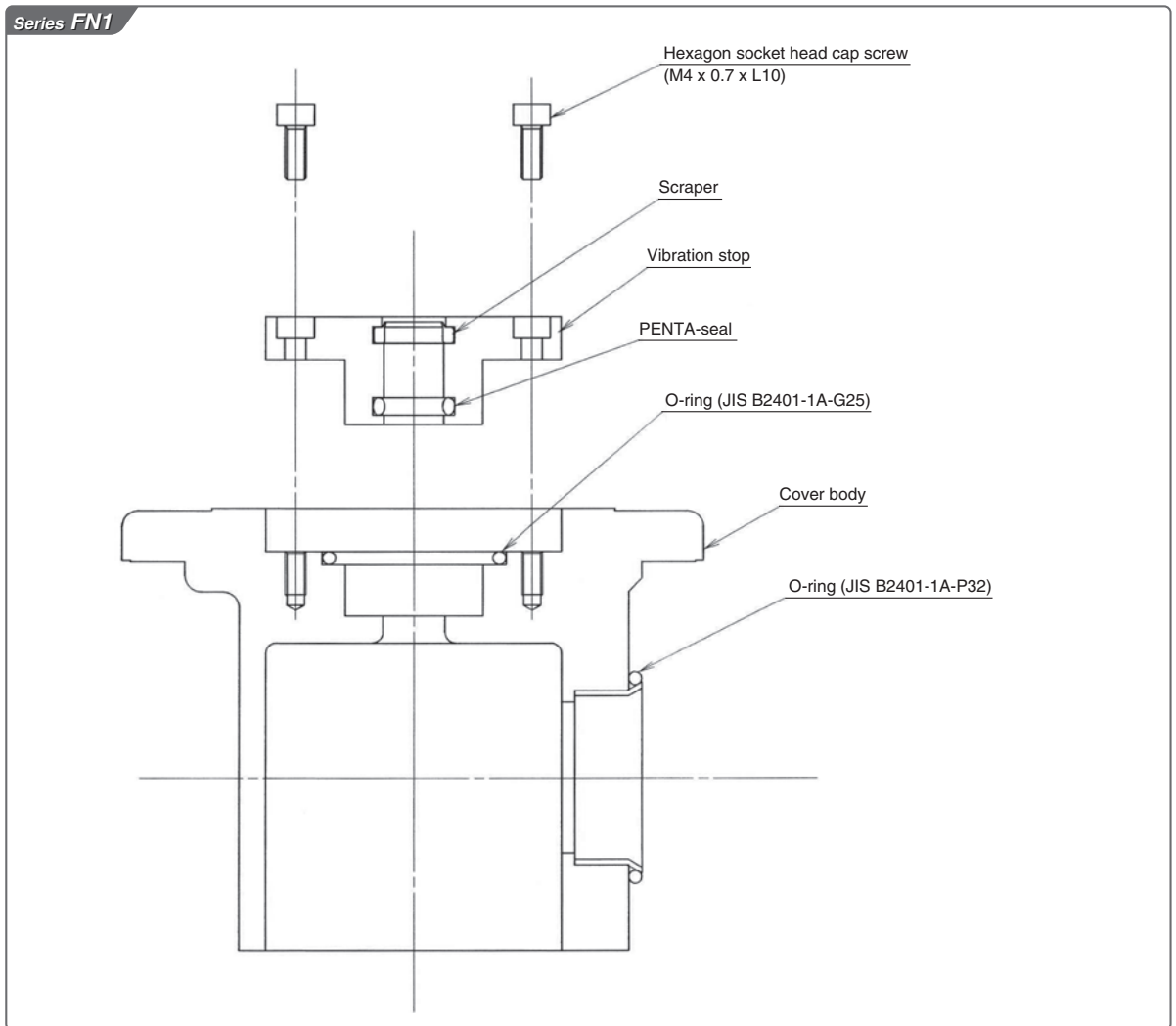

Actuators

Modular F.R.L.
Pressure Control Equipment

Air Preparation
Equipment

Industrial Filters

Replacement
Procedure

Actuators

Modular F.R.L.
Pressure Control Equipment

Industrial Filters

2. Disassembly

Series FN1

- 2-1. Remove the cover [Two M4 hexagon socket head cap screws See Figure 1]
 - 2-2. Remove the cylinder flange fixing screws (four M8 hexagon socket head cap screws), and remove the entire body of the cylinder. [Slide the entire body of the cylinder in the horizontal direction, and remove the cylinder from the joint. See Fig. 2]
 - 2-3. Remove the four struts. [See Fig. 2]
 - 2-4. Pull the cover assembly upward. [Pull out the entire body of the element. See Fig. 3]
 - 2-5. Remove the mounting bracket inside the cover assembly. [Remove the set screw, and turn the mounting bracket. See Fig. 4]
- For FN11□2□-10, two screws are mounted in the middle of the guide assembly [M3 See Fig. 4]
- 2-6. The element can now be pulled out of the cover.

Do not disassemble the element any further.

Note) Reassembly should be performed by reversing the disassembly procedure.

Refer to the schematic drawings for the assembly and disassembly procedures for the cover, seals etc.

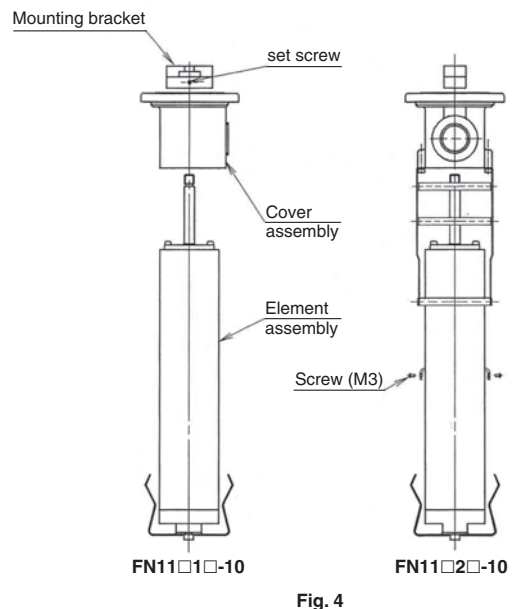
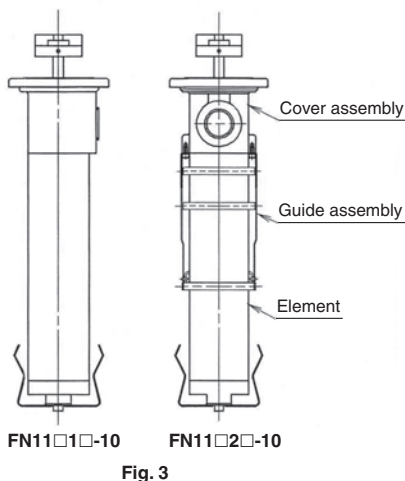
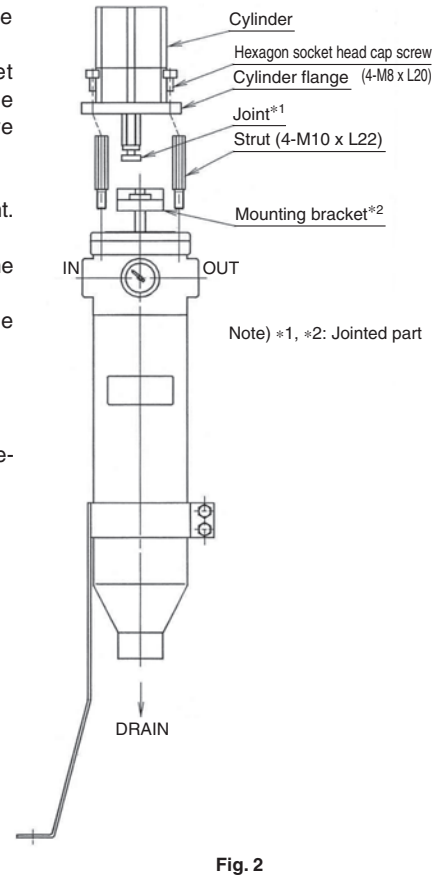
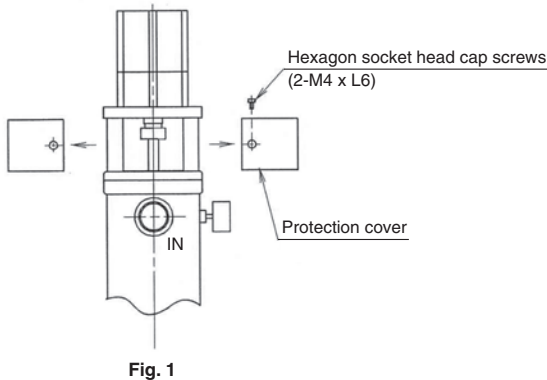

Series FN1/FN4 Replacement Procedure of Element 3

Series FN4

Basically, this filter does not need any maintenance, but if an element needs cleaning (differential pressure cannot be returned as dust adheres) or an element or a seal needs replacement, clean or replace the element by following the dismantling procedure below.

2-1. Stopping operation

- a. Stop the operation of filter.
- b. Close the valves at IN and OUT.
- c. Open the DRAIN valve to make the internal pressure zero and to exhaust all the fluid inside.

2-2. Removing protection cover

- a. Remove the set screws of a protection cover, and slide the cover to the side.
(M4 hexagon socket head cap screws at two parts)

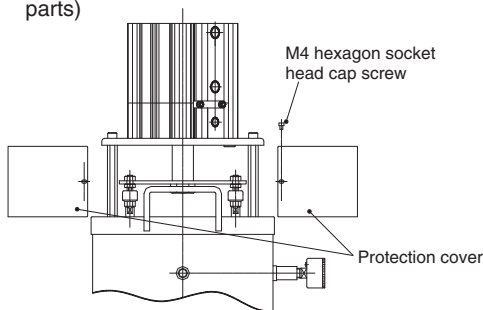

2-3. Removing cylinder

- a. Remove the M8 hexagon nut at four parts.
- b. Remove the cylinder flange holding bolts.
Holding bolt: M8 hexagon socket head cap screws at four parts up to the cylinder, and remove it.

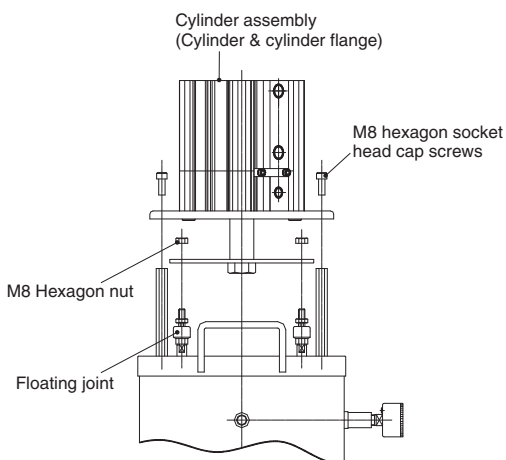

2-4. Taking out element assembly

- a. Remove the C shaped retaining ring at four parts.
- b. Withdraw the element assembly upward from the case.
* Remove the O-ring to the new one if it has any problems such as swelling.

[O-ring for replacement]
KT-FN41N (JIS B2401-1A-G90 and G80) (Material: NBR)
KT-FN41V (JIS B2401-4D-G90 and G80) (Material: FPM)

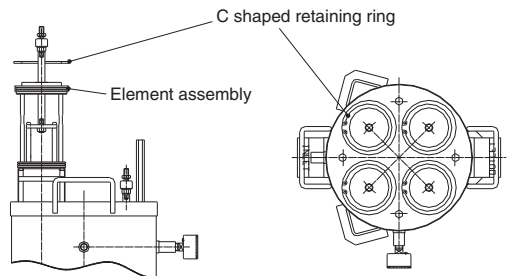

2-5. Removing element

- a. Remove the floating joint.
- b. Remove the intermediate screws of the guide assembly.
- c. Withdraw the element from the cover assembly.
* Do not dismantle the element further more.

[Replacement Element]
END400-005 (5 μ m Type)
END400-020 (20 μ m Type)
* 4 elements are required per unit.

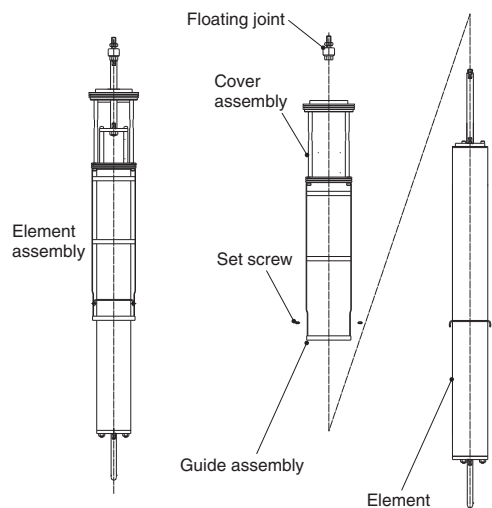

2-6. Cleaning element

- a. Clean the element taken out.
[Cleaning method] Ultrasonic cleaning, solvent cleaning, blowing cleaning, etc
* Do not clean it with acid or a hard brush.

2-7. Assembling and restarting

- a. Assemble it by following the dismantling procedure backward.
- b. For restarting, follow Section 3 "Operation" in the Operation Manual.

Actuators

Modular F.R.L.
Pressure Control Equipment

Air Preparation
Equipment

Industrial Filters

Replacement
Procedure

Actuators

Modular F.R.L.
Pressure Control Equipment

Industrial Filters

Safety Instructions

These safety instructions are intended to prevent hazardous situations and/or equipment damage. These instructions indicate the level of potential hazard with the labels of “**Caution**,” “**Warning**” or “**Danger**.” They are all important notes for safety and must be followed in addition to International Standards (ISO/IEC)*1, and other safety regulations.

 **Caution:** **Caution** indicates a hazard with a low level of risk which, if not avoided, could result in minor or moderate injury.

 **Warning:** **Warning** indicates a hazard with a medium level of risk which, if not avoided, could result in death or serious injury.

 **Danger :** **Danger** indicates a hazard with a high level of risk which, if not avoided, will result in death or serious injury.

*1) ISO 4414: Pneumatic fluid power – General rules relating to systems.
ISO 4413: Hydraulic fluid power – General rules relating to systems.
IEC 60204-1: Safety of machinery – Electrical equipment of machines.
(Part 1: General requirements)
ISO 10218-1: Manipulating industrial robots – Safety.
etc.

Warning

1. The compatibility of the product is the responsibility of the person who designs the equipment or decides its specifications.

Since the product specified here is used under various operating conditions, its compatibility with specific equipment must be decided by the person who designs the equipment or decides its specifications based on necessary analysis and test results. The expected performance and safety assurance of the equipment will be the responsibility of the person who has determined its compatibility with the product. This person should also continuously review all specifications of the product referring to its latest catalog information, with a view to giving due consideration to any possibility of equipment failure when configuring the equipment.

2. Only personnel with appropriate training should operate machinery and equipment.

The product specified here may become unsafe if handled incorrectly. The assembly, operation and maintenance of machines or equipment including our products must be performed by an operator who is appropriately trained and experienced.

3. Do not service or attempt to remove product and machinery/equipment until safety is confirmed.

1. The inspection and maintenance of machinery/equipment should only be performed after measures to prevent falling or runaway of the driven objects have been confirmed.
2. When the product is to be removed, confirm that the safety measures as mentioned above are implemented and the power from any appropriate source is cut, and read and understand the specific product precautions of all relevant products carefully.
3. Before machinery/equipment is restarted, take measures to prevent unexpected operation and malfunction.

4. Contact SMC beforehand and take special consideration of safety measures if the product is to be used in any of the following conditions.

1. Conditions and environments outside of the given specifications, or use outdoors or in a place exposed to direct sunlight.
2. Installation on equipment in conjunction with atomic energy, railways, air navigation, space, shipping, vehicles, military, medical treatment, combustion and recreation, or equipment in contact with food and beverages, emergency stop circuits, clutch and brake circuits in press applications, safety equipment or other applications unsuitable for the standard specifications described in the product catalog.
3. An application which could have negative effects on people, property, or animals requiring special safety analysis.
4. Use in an interlock circuit, which requires the provision of double interlock for possible failure by using a mechanical protective function, and periodical checks to confirm proper operation.

Caution

1. The product is provided for use in manufacturing industries.

The product herein described is basically provided for peaceful use in manufacturing industries.

If considering using the product in other industries, consult SMC beforehand and exchange specifications or a contract if necessary.

If anything is unclear, contact your nearest sales branch.

Limited warranty and Disclaimer/ Compliance Requirements

The product used is subject to the following “Limited warranty and Disclaimer” and “Compliance Requirements”.

Read and accept them before using the product.

Limited warranty and Disclaimer

1. The warranty period of the product is 1 year in service or 1.5 years after the product is delivered, whichever is first.*2)

Also, the product may have specified durability, running distance or replacement parts. Please consult your nearest sales branch.

2. For any failure or damage reported within the warranty period which is clearly our responsibility, a replacement product or necessary parts will be provided.

This limited warranty applies only to our product independently, and not to any other damage incurred due to the failure of the product.

3. Prior to using SMC products, please read and understand the warranty terms and disclaimers noted in the specified catalog for the particular products.

*2) **Vacuum pads are excluded from this 1 year warranty.**

A vacuum pad is a consumable part, so it is warranted for a year after it is delivered.

Also, even within the warranty period, the wear of a product due to the use of the vacuum pad or failure due to the deterioration of rubber material are not covered by the limited warranty.

Compliance Requirements

1. The use of SMC products with production equipment for the manufacture of weapons of mass destruction (WMD) or any other weapon is strictly prohibited.

2. The exports of SMC products or technology from one country to another are governed by the relevant security laws and regulations of the countries involved in the transaction. Prior to the shipment of a SMC product to another country, assure that all local rules governing that export are known and followed.

Safety Instructions

Be sure to read “Handling Precautions for SMC Products” (M-E03-3) before using.