



Industrial Safety Systems



L2000 and L4000
Single-beam Photoelectric Safety Switches



SICK
Sensor Intelligence.



- Compatible with safety controllers such as UE410 Flexi, UE44xx
- Inputs/outputs compliant with EN 61131
- Large scanning ranges
- Small design (M30/M18)
- Metal and plastic version
- Radial optics (90° deflector mirror)
- Simple diagnostics and service



Overview of technical specifications

Scanning range (depending on type)	0 m ... 5 m / 0 m ... 10 m / 0 m ... 60 m
Construction size (depending on type)	M18 x 107.7 mm / M18 x 97.7 mm / M30 x 100 mm
Enclosure rating	IP 67
Ambient operating temperature from ... to	-40 °C ... +55 °C
Type	Type 4 (IEC 61496) ¹⁾
Performance Level	PL e (EN ISO 13849) ¹⁾

¹⁾ Only in conjunction with suitable testing device e.g. UE410 Flexi, UE44xx

Product description

The L41 single-beam photoelectric safety switch comprises a sender and a receiver. The correct function of the L41 can be checked with the aid of the test input on the sender.

In connection with a suitable evaluation unit, e.g. UE410 Flexi, UE44xx, performance levels up to PL e in accordance with

EN ISO 13849-1 can be achieved.

Colour LEDs provide in-situ information on operational status.

The variety of scanning ranges to suit your needs, the device's suitability for outdoor applications, and the use of deflector mirrors enable more complex protection tasks to be realised.

In-system added value

Combination with SICK safe control solutions

Combination with	Type of output	Number of sensors	Restart interlock	External device monitoring	Muting
UE410 Flexi main unit	PNP, monitored, short-circuit protected	4	✓	✓	✓
UE410 Flexi extension unit		4	✓	✓	✓
UE4470	Source output (PNP)	4	✓	✓	✓
UE4457	Bipolar type	4	✓	✓	✓

→ You can find more combinations using the product finder at www.mysick.com

Applications

→ You can find more applications using the application finder at www.mysick.com

- Robots
- Processing machines
- Machining centres
- Palletiser systems
- High-bay warehouses

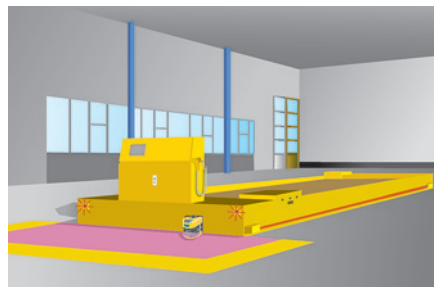

Lateral protection on an automated guided vehicle

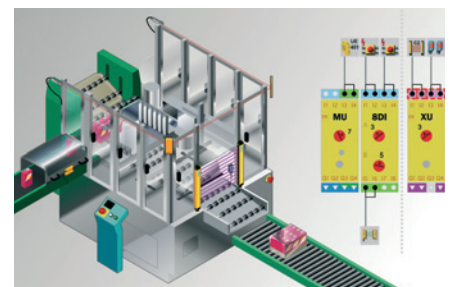

Door monitoring on a packaging machine

Further information	Page
→ Dimensional drawings	4
→ Connection diagrams	5
→ Accessories	6

Ordering information

■ Plug M12 x 4, angled

Scanning range	Optical axis	Construction size	Housing material	System part	Type	Part number
0 m ... 60 m	Axial	M30 x 100 mm	Metal	Sender	L41S-33MA2A	6034863
				Receiver	L41E-33MA2A	6034862

■ Plug M12 x 4, straight

Scanning range	Optical axis	Construction size	Housing material	System part	Type	Part number
0 m ... 10 m	Axial	M18 x 97.7 mm	Plastic	Sender	L41S-21KA1A	6034864
				Receiver	L41E-21KA1A	6034865
			Metal	Sender	L41S-21MA1A	6034866
				Receiver	L41E-21MA1A	6034867
0 m ... 5 m	Radial	M18 x 107.7 mm	Metal	Sender	L41S-11MA1A	6034868
				Receiver	L41E-11MA1A	6034869

Detailed technical specifications

→ You can find further data in the operating instructions. Download at www.mysick.com

General data

	Sender	Receiver
Scanning range (depending on type)	0 m ... 10 m / 0 m ... 60 m 0 m ... 5 m	
	Axial optic Radial optic	
Number of beams	1	
Optical axis (depending on type)	Radial/axial	
Light beam diameter (depending on type)	12 mm (M18) / 26 mm (M30)	
Aperture angle/receive angle	± 2.5° / ± 2.5°	
Light sender/type of light	LED (visible red light)	-
Wave length	660 nm	-
Protection class	III	
Enclosure rating	IP 67	
Safety related parameters	Type 4 (IEC 61496) ¹⁾ SILCL3 (IEC 62061), SIL3 (IEC 61508) Category 4 (EN ISO 13849) ¹⁾ PL e (EN ISO 13849) ¹⁾	
	3.2 x 10 ⁻¹⁰	4.9 x 10 ⁻¹⁰
	20 a	
Design	Cylindrical	
Dimensions (diameter x length) (depending on type)	M18 x 107.7 mm / M18 x 97.7 mm / M30 x 100 mm	
Housing material (depending on type)	Brass nickel-plated / Plastic	
Lens material	Glass	
Ambient operating temperature from ... to	-40 °C ... +55 °C	
Storage temperature from ... to	-40 °C ... +55 °C	
Air humidity from ... to	Non-dewing, 15 % ... 95 %	
Vibration resistance	5 g, 10 Hz ... 55 Hz (IEC 60068-2-6)	
Shock resistance	10 g, 16 ms (IEC 60068-2-29)	
Weight (depending on type)	67 g / 30 g	

¹⁾ Only in conjunction with suitable testing device e.g. UE410 Flexi, UE44xx

Electrical data

	Sender	Receiver
Connection type (depending on type)	Straight plug M12 x 4 / angled plug M12 x 4	
Supply voltage V_s	24 V DC (19.2 V DC ... 28.8 V DC)	
Maximum power consumption	Max. 20 mA	Max. 30 mA
Switching outputs	-	PNP, Q ¹⁾
Maximum response time	-	Max. 200 μ S
Maximum switching current	-	70 mA

¹⁾ Short-circuit protected

Dimensional drawings

M18, radial

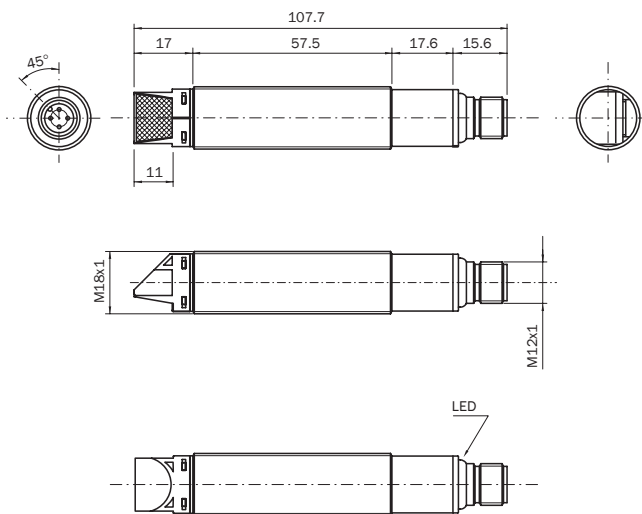

M18, axial

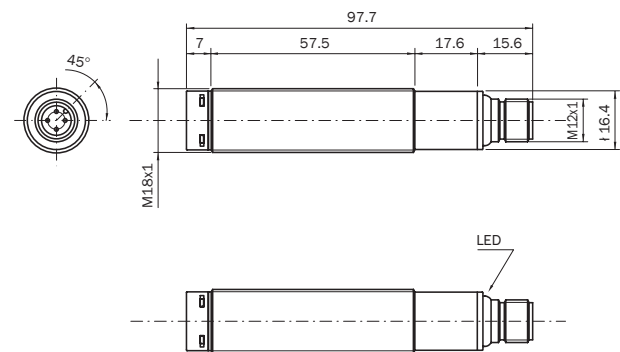

M30, axial

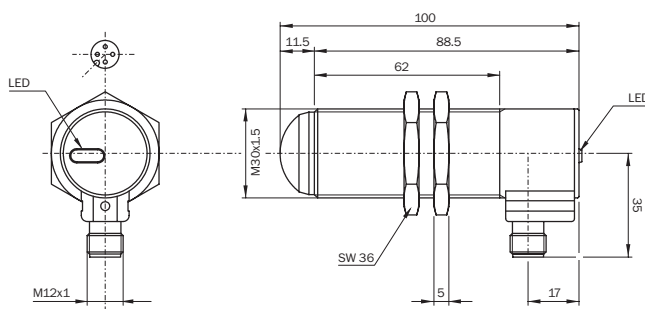

Dimensions in mm

Connection diagrams

→ You can find more connection diagrams at www.mysick.com

3 x L41 (cascaded) on UE410 Flexi main unit and extension unit

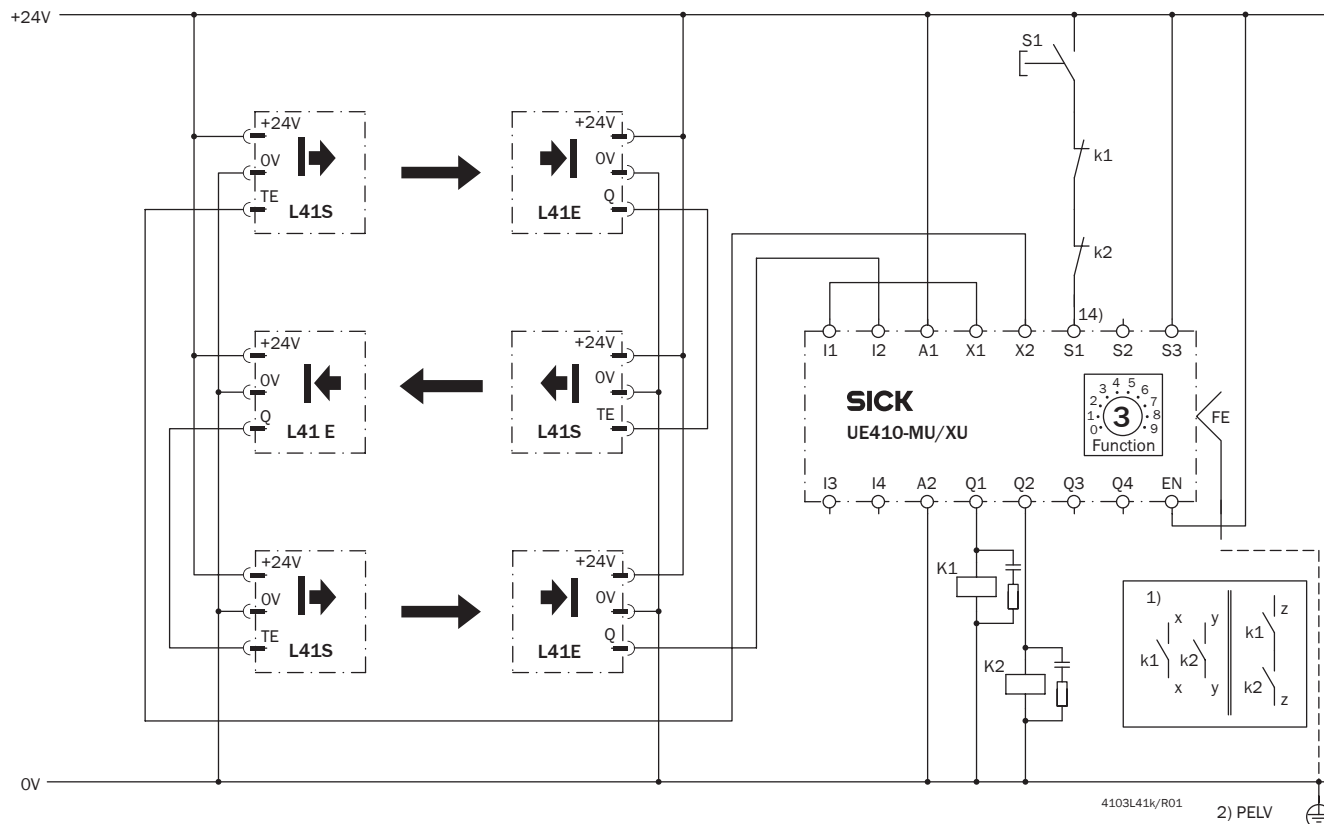

Task

Integration of three cascaded L4000 (L41) family single-beam photoelectric safety switches with a UE410-MU/XU safety controller into a relay controller/contactor controller.

Operating mode: with restart interlock and with external device monitoring.

Function

When the input conditions are valid, the system is ready for switch on and waits for an input signal/switch-on signal. The system is enabled by pressing and releasing the button S1. The related output on the UE410-MU/XU carries power. If the input conditions are no longer met, the related outputs on the UE410-MU/XU shut down.

Possible errors

The incorrect function of the contactors K1 and K2 will be detected. The shutdown function is retained.

On manipulation (e.g. jamming) of the button S1, the system does not enable the output current circuits.

Comments

1) Output circuits: These contacts are to be connected to the controller such that, with the output circuit open, the dangerous state is disabled. For categories 4 and 3, the integration must be dual-channel (x/y paths). Single-channel integration in the control (z path) is only possible with a single-channel control and taking the risk analysis into account.

2) PELV as required in EN 60204-1 / 6.4

Optical short-circuits must be avoided. Take note of the operating instructions for the devices integrated. The safety-related parameters (safety integration level and response time) are dependent on the types used.

Accessories

Mounting systems

Description	Construction size	Mounting	Property	Type	Part number
Mounting adapter	M18	With fixing holes 4 mm	Adjustable	BEF-HA-M18-R	5313513
	M30	With fastening thread M6		BEF-HA-M30-A	5311527
		With fixing holes for M4		BEF-HA-M30-R	5311528
Mounting bracket	M18	—	—	BEF-WN-M18	5308446
	M30	—	—	BEF-WN-M30	5308445

Connectors

Description	Connection type	Cable alignment	Cable length	Cable material	Type	Part number	
Female connector	M12 x 4	Straight	2 m	PVC	DOL-1204-G02M	6009382	
			5 m	PVC	DOL-1204-G05M	6009866	
				PUR halogen free	DOL-1204-G05MC	6025901	
			10 m	PVC	DOL-1204-G10M	6010543	
		Angled	2 m	PVC	DOL-1204-W02M	6009383	
			5 m	PVC	DOL-1204-W05M	6009867	
				PUR halogen free	DOL-1204-W05MC	6025904	
			10 m	PVC	DOL-1204-W10M	6010541	
		Straight	Can be preformed	—	—	DOS-1204-G	6007302
				Angled	—	DOS-1204-W	6007303
Male connector	M12 x 4	Straight	—	—	STE-1204-G	6009932	

Deflector mirrors

Description	Mirror surface	Delivery	Type	Part number
Deflector mirrors ¹⁾	105 mm x 160 mm		PNS105-1	1004076
	75 mm x 80 mm	Including mounting adapter (two pieces swivel mount)	PNS75-008	1026647
	96 mm x 124 mm		PSK1	1005229
	—	For 90° deflection, incl. mounting set, not suitable for column mounting	PSK45	5306053
Bracket	—	For PSK 1	BEF-GH	2009292
Spring fastening	—		—	2012473

¹⁾ Reduction of the scanning range

Laser alignment aid

Type	Description	Part number
Laser alignment aid - AR60	—	1015741
AR60 adapter	For L2000 and L4000, M30	5311529
	For L2000 and L4000, M18	5313533

Overview of technical specifications

Scanning range (depending on type)	0 m ... 5 m / 0 m ... 16 m / 0 m ... 60 m
Construction size (depending on type)	M18 / M30
Enclosure rating	IP 67
Ambient operating temperature from ... to	-40 °C ... +55 °C
Type	Type 2 (IEC 61496) ¹⁾
Performance Level	PL c (EN ISO 13849) ¹⁾

¹⁾ Only in conjunction with suitable testing device e.g. UE410 Flexi, UE44xx

Product description

The L21 single-beam photoelectric safety switch comprises a sender and a receiver. The correct function of the L21 can be checked with the aid of the test input on the sender.

In connection with a suitable evaluation unit, e.g. UE410 Flexi, DeviceNet safety products, performance levels up to PL c in

accordance with EN ISO 13849-1 can be achieved.

Colour LEDs provide in-situ information on operational status.

The variety of scanning ranges to suit your needs, the device's suitability for outdoor applications, and the use of deflector mirrors enable more complex protection tasks to be realised.

In-system added value

Combination with SICK safe control solutions

Combination with	Type of output	Number of sensors	Restart interlock	External device monitoring	Muting
UE410 Flexi main unit	PNP, monitored, short-circuit protected	4	✓	✓	✓
UE410 Flexi extension unit		4	✓	✓	✓
UE4470	Source output (PNP)	4	✓	✓	✓
UE4457	Bipolar type	4	✓	✓	✓

→ You can find more combinations using the product finder at www.mysick.com

Applications

→ You can find more applications using the application finder at www.mysick.com

- Robots
- Processing machines
- Machining centres
- Palletiser systems
- High-bay warehouses

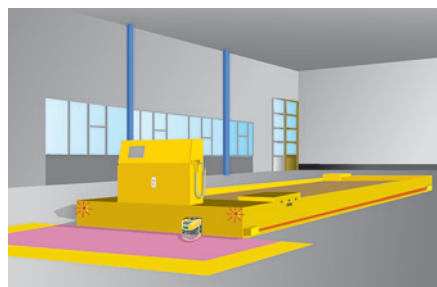

Lateral protection on an automated guided vehicle

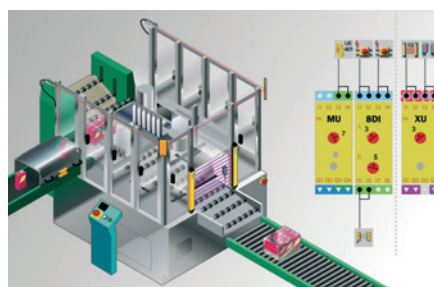

Door monitoring on a packaging machine



- Compatible with safety controllers such as UE410 Flexi and DeviceNet Safety products
- Inputs/outputs compliant with EN 61131
- Large scanning ranges
- Small design (M30/M18)
- Metal and plastic version
- Radial optics (90° deflector mirror)
- Simple diagnostics and service



Further information	Page
→ Ordering information	8
→ Detailed technical specifications	9
→ Dimensional drawings	10
→ Connection diagrams	11
→ Accessories	12

Ordering information

■ Plug M12 x 4, angled

Scanning range	Optical axis	Construction size	Housing material	System part	Type	Part number
0 m ... 60 m	Axial	M30 x 100 mm	Metal	Sender	L21S-33MA2A	6034870
				Receiver	L21E-33MA2A	6034871

■ Plug M12 x 4, straight

Scanning range	Optical axis	Construction size	Housing material	System part	Type	Part number
0 m ... 16 m	Axial	M18 x 97.7 mm	Plastic	Sender	L21S-21KA1A	6034872
				Receiver	L21E-21KA1A	6034873
			Metal	Sender	L21S-21MA1A	6034874
				Receiver	L21E-21MA1A	6034875
0 m ... 5 m	Radial	M18 x 107.7 mm	Metal	Sender	L21S-11MA1A	6034876
				Receiver	L21E-11MA1A	6034877

Detailed technical specifications

→ You can find further data in the operating instructions. Download at www.mysick.com

General data

	Sender	Receiver
Scanning range (depending on type)	0 m ... 5 m / 0 m ... 16 m / 0 m ... 60 m	
Number of beams	1	
Optical axis (depending on type)	Radial/axial	
Light beam diameter (depending on type)	12 mm (M18) / 26 mm (M30)	
Aperture angle/receive angle	$\pm 5^\circ / \pm 5^\circ$	
Light sender/type of light	LED (visible red light)	-
Wave length	660 nm	-
Protection class	III	
Enclosure rating	IP 67	
Safety related parameters	Type 2 (EN 61496) ¹⁾ SILCL1 (IEC 62061), SIL1 (IEC 61508) Category 2 (EN ISO 13849) ¹⁾ PL c (EN ISO 13849) ¹⁾ PFHd (probability of a dangerous failure/hour) $1,0 \times 10^{-6}$ TM (Mission Time) 20 a	
Design	Cylindrical	
Dimensions (diameter x length) (depending on type)	M18 x 107.7 mm / M18 x 97.7 mm / M30 x 100 mm	
Housing material (depending on type)	Brass nickel-plated / Plastic	
Ambient operating temperature from ... to	-40 °C ... +55 °C	
Storage temperature from ... to	-40 °C ... +75 °C	
Air humidity from ... to	Non-dewing, 15 % ... 95 %	
Vibration resistance	5 g, 10 Hz ... 55 Hz (IEC 60068-2-6)	
Shock resistance	10 g, 16 ms (IEC 60068-2-29)	
Weight (depending on type)	67 g / 30 g	

¹⁾ Only in conjunction with suitable testing device, e.g. UE410 Flexi, UE44xx

Electrical data

Connection type (depending on type)	Straight plug M12 x 4 / angled plug M12 x 4	
Supply voltage V_s	24 V DC (19.2 V DC ... 28.8 V DC)	
Maximum power consumption	Max. 20 mA	Max. 30 mA
Switching outputs	-	PNP, Q ¹⁾
Maximum response time	-	Max. 200 μ S
Maximum switching current	-	70 mA

¹⁾ Short-circuit protected

Dimensional drawings

M18, radial

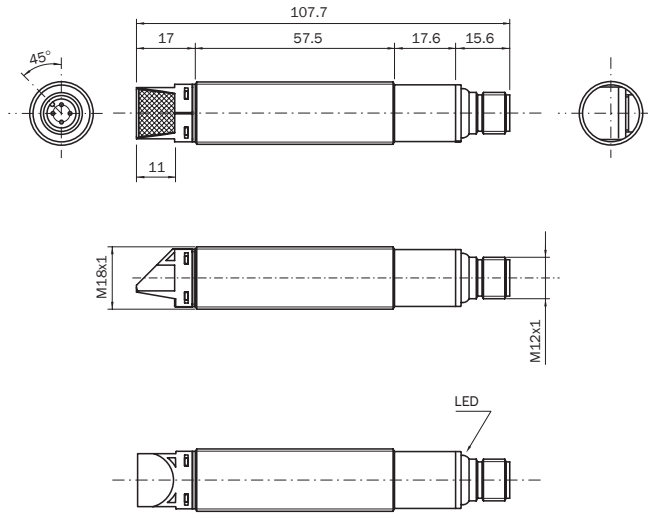

M18, axial

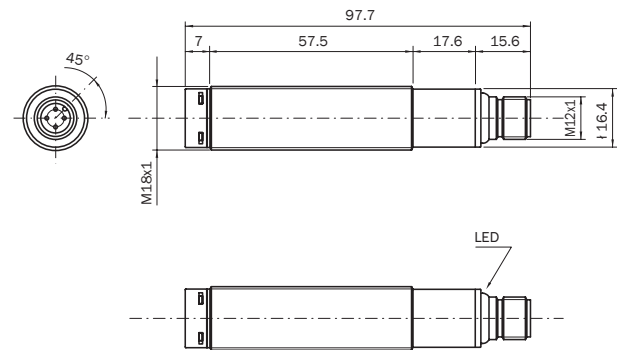

M30, axial

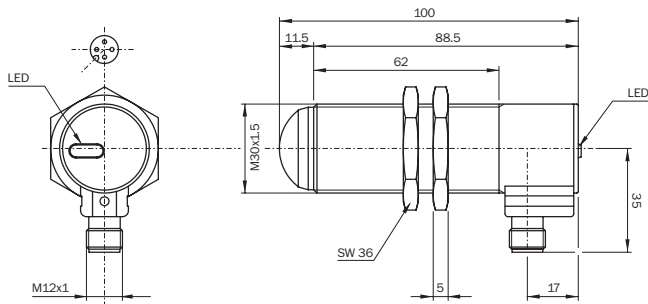

Dimensions in mm

Connection diagrams

→ You can find more connection diagrams at www.mysick.com

3 x L21 (cascaded) with UE410 Flexi main unit and extension unit on safety relay UE10-30S

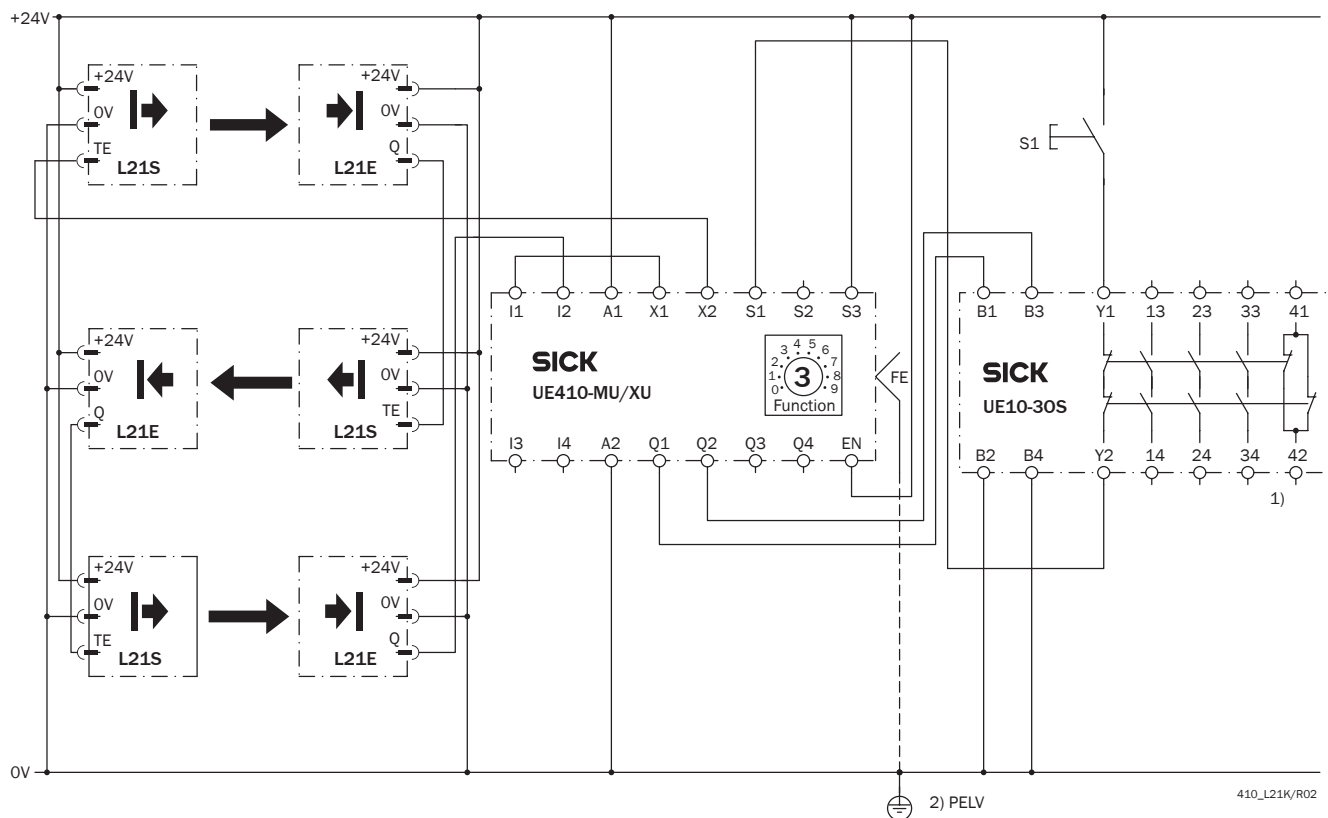

Task

Integration of three cascaded L2000 (L21) family single-beam photoelectric safety switches with a UE410-MU/XU safety controller in a UE10-30S safety relay.

Operating mode: with restart interlock and external device monitoring.

Function

The system is ready when the light path is clear and the UE10-30S is de-energised and functioning correctly. The outputs Q1 and Q2 on the UE410-MU/XU are live. The UE10-30S is switched on. If one of the light beams is interrupted, the outputs Q1 and Q2 on the UE410-MU/XU shut down the UE10-30S.

Possible errors

Malfunctions in the UE10-30S will be detected. The shutdown function is retained.

Comments

1) Output circuits: These contacts are to be connected to the controller such that, with the output circuit open, the dangerous state is disabled. For categories 4 and 3, the integration must be dual-channel (x/y paths). Single-channel integration in the control (z path) is only possible with a single-channel control and taking the risk analysis into account.

2) PELV as required in EN 60204-1 / 6.4

Take note of the operating instructions for the devices integrated. The safety-related parameters (safety integration level and response time) are dependent on the types used.

Accessories

Mounting systems

Description	Construction size	Mounting	Property	Type	Part number
Mounting adapter	M18	With fixing holes 4 mm	Adjustable	BEF-HA-M18-R	5313513
	M30	With fastening thread M6		BEF-HA-M30-A	5311527
		With fixing holes for M4		BEF-HA-M30-R	5311528
Mounting bracket	M18	—	—	BEF-WN-M18	5308446
	M30	—	—	BEF-WN-M30	5308445

Connectors

Description	Connection type	Cable alignment	Cable length	Cable material	Type	Part number	
Female connector	M12 x 4	Straight	2 m	PVC	DOL-1204-G02M	6009382	
			5 m	PVC	DOL-1204-G05M	6009866	
				PUR halogen free	DOL-1204-G05MC	6025901	
			10 m	PVC	DOL-1204-G10M	6010543	
		Angled	2 m	PVC	DOL-1204-W02M	6009383	
			5 m	PVC	DOL-1204-W05M	6009867	
				PUR halogen free	DOL-1204-W05MC	6025904	
			10 m	PVC	DOL-1204-W10M	6010541	
		Straight	Can be preformed	—	—	DOS-1204-G	6007302
				—	—	DOS-1204-W	6007303
Male connector	M12 x 4	Straight	—	—	STE-1204-G	6009932	

Deflector mirrors

Description	Mirror surface	Delivery	Type	Part number
Deflector mirrors ¹⁾	105 mm x 160 mm		PNS105-1	1004076
	75 mm x 80 mm	Including mounting adapter (two pieces swivel mount)	PNS75-008	1026647
	96 mm x 124 mm		PSK1	1005229
	—	For 90° deflection, incl. mounting set, not suitable for column mounting	PSK45	5306053
Bracket	—	For PSK 1	BEF-GH	2009292
Spring fastening	—		—	2012473

¹⁾ Reduction of the scanning range

Laser alignment aid

Type	Description	Part number
Laser alignment aid - AR60	—	1015741
AR60 adapter	For L2000 and L4000, M30	5311529
	For L2000 and L4000, M18	5313533

Overview of technical specifications

Scanning range (typical/maximum)	0 m ... 25 m / 0 m ... 35 m
Light sender/type of light	LED/visible red light
Construction size	80.6 mm x 24.6 mm x 54 mm
Enclosure rating	IP 67
Ambient operating temperature from ... to	-40 °C ... +60 °C
Type	Type 2 (IEC 61496) ¹⁾
Performance Level	PL c (EN ISO 13849) ¹⁾

¹⁾ Only in conjunction with suitable testing device e.g. UE410 Flexi, UE44xx

Product description

The L27 single-beam photoelectric safety switch comprises a sender and a receiver. The correct function of the L27 can be checked with the aid of the test input on the sender.

In connection with a suitable evaluation unit, e.g. UE410 Flexi and DeviceNet Safety products, performance levels up to PL c in

accordance with EN ISO 13849-1 can be achieved.

Colour LEDs provide in-situ information on operational status.

The variety of scanning ranges to suit your needs, the device's suitability for outdoor applications, and the use of deflector mirrors enable more complex protection tasks to be realised.

In-system added value

Combination with SICK safe control solutions

Combination with	Type of output	Number of sensors	Restart interlock	External device monitoring	Muting
UE410 Flexi main unit	PNP, monitored, short-circuit protected	4	✓	✓	✓
UE410 Flexi extension unit		4	✓	✓	✓
UE4470	Source output (PNP)	4	✓	✓	✓
UE4457	Bipolar type	4	✓	✓	✓

→ You can find more combinations using the product finder at www.mysick.com

Applications

→ You can find more applications using the application finder at www.mysick.com

- Processing machines
- Machining centres
- Palletiser systems

- High-bay warehouses
- Transfer lines

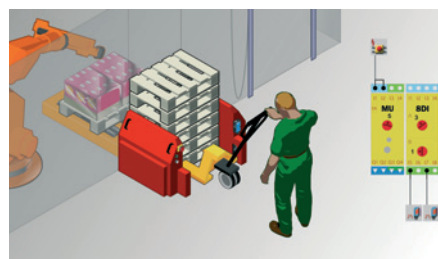

Protection of a pallet loading station

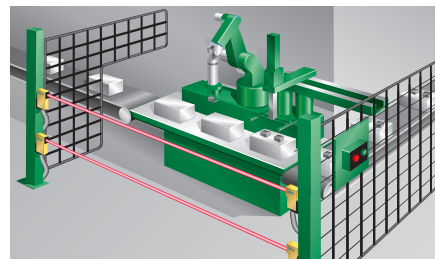

Access protection on a machining centre



- Compatible with safety controllers such as UE410 Flexi and DeviceNet Safety products
- Inputs/outputs compliant with EN 61131
- Integrated heating
- High scanning range
- Plastic housing, ABS
- Compact design
- Red light



Further information	Page
→ Detailed technical specifications	14
→ Dimensional drawings	15
→ Connection diagrams	16
→ Accessories	17

Ordering information

Scanning range	Connection type	System part	Heating	Type	Part number
0 m ... 25 m	Plug M12 x 4	Sender	✓	L27S-3D2450	2043877
		Receiver	✓	L27E-3P2450	2043876
		Sender	—	L27S-3D2430	2043906
		Receiver	—	L27E-3P2430	2043904

Detailed technical specifications

→ You can find further data in the operating instructions. Download at www.mysick.com

General data

	Sender	Receiver
Scanning range (typical/maximum)	0 m ... 25 m / 0 m ... 35 m	
Number of beams	1	
Light spot diameter (distance)	1200 mm/25 m	
Aperture angle/receive angle	± 5°/± 5°	
Light sender/type of light	LED/visible red light	—
Wave length	660 nm	—
Average service life (TA)	100000 h (+25 °C)	—
Protection class	II	
Enclosure rating	IP 67	
Safety related parameters	Type 2 (EN 61496) ¹⁾ SILCL1 (IEC 62061), SIL1 (IEC 61508) Category 2 (EN ISO 13849) ¹⁾ PL c (EN ISO 13849) ¹⁾ PFHd (probability of a dangerous failure/hour) 1,0 x 10 ⁻⁶ TM (Mission Time) 20 a	
Design	Rectangular	
Dimensions (W x H x D)	80.6 mm x 24.6 mm x 54 mm	
Housing material	ABS	
Ambient operating temperature from ... to	-40 °C ... +60 °C	
Storage temperature from ... to	-40 °C ... +75 °C	
Weight	100 g	

¹⁾ Only in conjunction with suitable testing device, e.g. UE410 Flexi, UE44xx

Electrical data

	Sender	Receiver
Connection type	Plug M12 x 4	
Supply voltage V_s	24 V DC (16.8 V DC ... 28.8 V DC) ¹⁾	
Maximum power consumption	Max. 35 mA	Max. 25 mA
Test input voltage	U_V (sender on), 0 V DC (sender off)	-
Test duration	2.6 ms ²⁾	-
Switching outputs	-	PNP, Q and \bar{Q} ³⁾
Maximum response time	-	Max. 540 μ S
Maximum switching sequence	-	1000 Hz
Maximum switching current	-	100 mA
Diagnosis display	LED	

¹⁾ Reverse-polarity protected

²⁾ Signal propagation time for resistive load, for test signal application (sender) and output signal reaction (receiver)

³⁾ Short-circuit protected interference suppression

Dimensional drawings

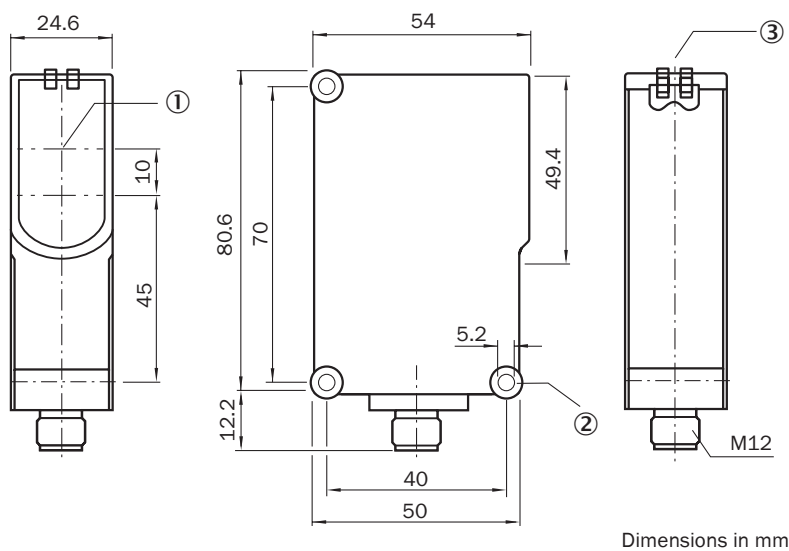

① Centre of optical axis

② Fastening hole \varnothing 5.2 mm

③ LED

Connection diagrams

→ You can find more connection diagrams at www.mysick.com

3 x L27 on UE410 Flexi input expansion unit UE410-8DI

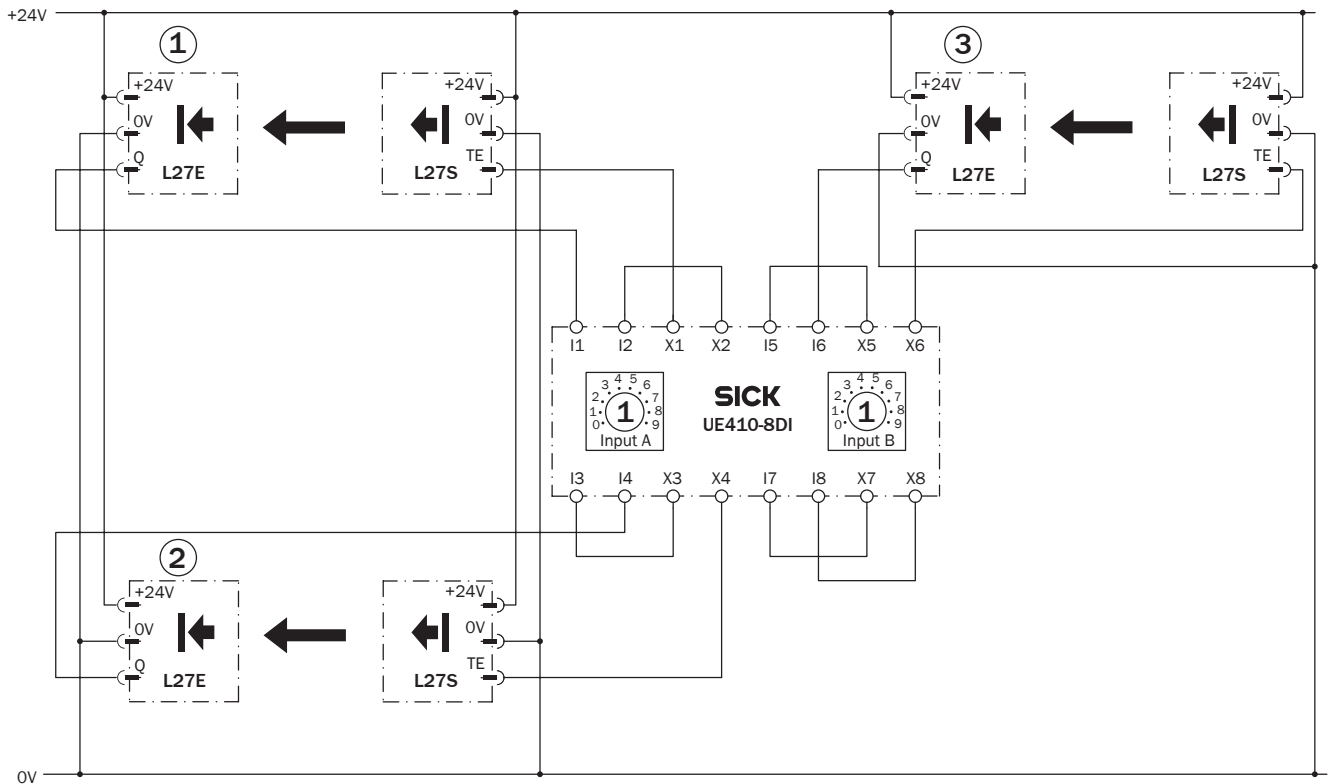

4103L27_/R01

Task

Integration of three L2000 (L27) family single-beam photoelectric safety switches in a UE410-8DI input expansion unit.

Function

The sensors switch when the light beam is clear. When sensor 1 and sensor 2 switch, input condition input A is met. When sensor 3 has switched, input condition input B is met. If a light beam is interrupted, the related input condition (input A or input B) shuts down the UE410-8DI.

Possible errors

A UE410-8DI has two test pulse generators. This means that short-circuits between odd (X1) and evenly (X2) numbered out-

puts will be detected. Short-circuits between two odd (i.e. X1 and X3) or two evenly (i.e. X2 and X4) numbered outputs will not be detected. In this case short-circuits between X1 and X4 and X1 and X6 are detected, short-circuits between X4 and X6 are not detected.

Comments

Take note of the operating instructions for the devices integrated.

The safety-related parameters (safety integration level and response time) are dependent on the types used.

Accessories

Mounting systems

Property	Delivery	Type	Part number
Mounting bracket	For L27	BEF-WN-W27	2009122

Connectors

Description	Connection type	Cable alignment	Cable length	Cable material	Type	Part number
Female connector	M12 x 4	Straight	2 m	PVC	DOL-1204-G02M	6009382
			5 m	PVC	DOL-1204-G05M	6009866
			—	—	DOS-1204-G	6007302

Deflector mirrors

Description	Mirror surface	Delivery	Type	Part number
Deflector mirrors ¹⁾	105 mm x 160 mm		PNS105-1	1004076
	75 mm x 80 mm	Including mounting adapter (two pieces swivel mount)	PNS75-008	1026647
	96 mm x 124 mm		PSK1	1005229
	—	For 90° deflection, incl. mounting set, not suitable for column mounting	PSK45	5306053
Bracket	—	For PSK 1	BEF-GH	2009292
Spring fastening	—		—	2012473

¹⁾ Reduction of the scanning range



- Compatible with safety controllers such as UE410 Flexi and DeviceNet Safety products
- Inputs/outputs compliant with EN 61131
- Compact design
- Red light
- Plastic housing, ABS



Overview of technical specifications

Scanning range (typical/maximum)	0 m ... 12 m / 0 m ... 18 m
Light sender/type of light	LED/visible red light
Construction size	75.5 mm x 17.6 mm x 33.5 mm
Enclosure rating	IP 67
Ambient operating temperature from ... to	-40 °C ... +60 °C
Type	Type 2 (IEC 61496) ¹⁾
Performance Level	PL c (EN ISO 13849) ¹⁾

¹⁾ Only in conjunction with suitable testing device e.g. UE410 Flexi, UE44xx

Product description

The L28 single-beam photoelectric safety switch comprises a sender and a receiver. The correct function of the L28 can be checked with the aid of the test input on the sender.

In connection with a suitable evaluation unit, e.g. UE410 Flexi and DeviceNet Safety products, performance levels up to PL c in

accordance with EN ISO 13849-1 can be achieved.

Colour LEDs provide in-situ information on operational status.

The variety of scanning ranges to suit your needs, the device's suitability for outdoor applications, and the use of deflector mirrors enable more complex protection tasks to be realised.

In-system added value

Combination with SICK safe control solutions

Combination with	Type of output	Number of sensors	Restart interlock	External device monitoring	Muting
UE410 Flexi main unit	PNP, monitored, short-circuit protected	4	✓	✓	✓
UE410 Flexi extension unit		4	✓	✓	✓
UE4470	Source output (PNP)	4	✓	✓	✓
UE4457	Bipolar type	4	✓	✓	✓

→ You can find more combinations using the product finder at www.mysick.com

Applications

→ You can find more applications using the application finder at www.mysick.com

- Processing machines
- Machining centres
- Palletiser systems
- High-bay warehouses
- Transfer lines

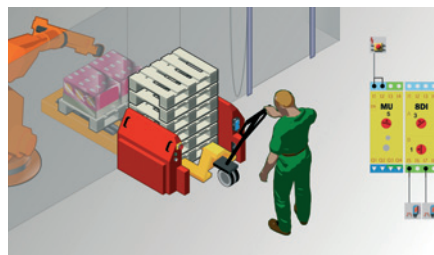

Protection of a pallet loading station

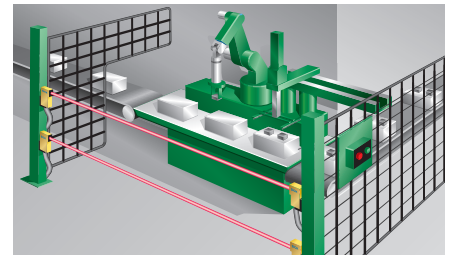

Access protection on a machining centre

Further information	Page
→ Dimensional drawings	20
→ Connection diagrams	21
→ Accessories	22

Ordering information

Scanning range	Connection type	System part	Type	Part number
0 m ... 12 m	Plug M12 x 4	Sender	L28S-3D2431	2044515
		Receiver	L28E-3P2431	2044516

Detailed technical specifications

→ You can find further data in the operating instructions. Download at www.mysick.com

General data

	Sender	Receiver
Scanning range (typical/maximum)	0 m ... 12 m / 0 m ... 18 m	
Number of beams	1	
Light spot diameter (distance)	300 mm/10 m	
Aperture angle/receive angle	± 5°/± 5°	
Light sender/type of light	LED/visible red light	-
Wave length	660 nm	-
Average service life (T _A)	100000 h (+25 °C)	-
Protection class	II	
Enclosure rating	IP 67	
Safety related parameters	Type 2 (EN 61496) ¹⁾ SILCL1 (IEC 62061), SIL1 (IEC 61508) Category 2 (EN ISO 13849) ¹⁾ PL c (EN ISO 13849) ¹⁾ PFHd (probability of a dangerous failure/hour) 1,0 x 10 ⁻⁶ TM (Mission Time) 20 a	
Design	Rectangular	
Dimensions (W x H x D)	75.5 mm x 17.6 mm x 33.5 mm	
Housing material	ABS	
Ambient operating temperature from ... to	-40 °C ... +60 °C	
Storage temperature from ... to	-40 °C ... +75 °C	
Weight	40 g	

¹⁾ Only in conjunction with suitable testing device e.g. UE410 Flexi, UE44xx

Electrical data

	Sender	Receiver
Connection type	Plug M12 x 4	
Supply voltage V_s	24 V DC (16.8 V DC ... 28.8 V DC) ¹⁾	
Maximum power consumption	Max. 35 mA	Max. 25 mA
Test input voltage	U_V (sender on), 0 V DC (sender off)	-
Test duration	2 ms ²⁾	-
Switching outputs	-	PNP, Q and \bar{Q} ³⁾
Maximum response time	-	Max. 500 μ S
Maximum switching sequence	-	1000 Hz
Maximum switching current	-	100 mA
Diagnosis display	LED	

¹⁾ Reverse-polarity protected

²⁾ Signal propagation time for resistive load, for test signal application (sender) and output signal reaction (receiver)

³⁾ Short-circuit protected interference suppression

Dimensional drawings

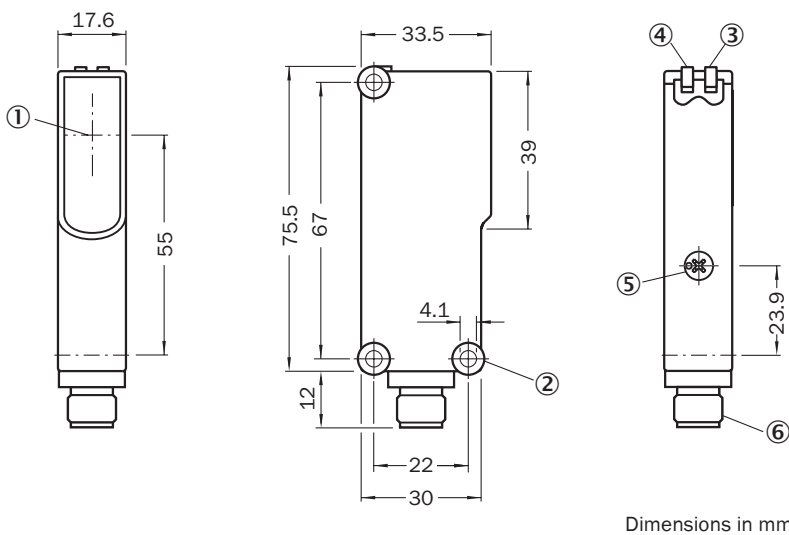

- ① Centre of optical axis
- ② Fastening hole
- ③ LED, yellow; light reception status
- ④ LED, green; operating voltage active
- ⑤ Sensitivity adjuster on receiver
- ⑥ Device plug M12, 4-pin

Connection diagrams

→ You can find more connection diagrams at www.mysick.com

3 x L28 on UE410 Flexi input expansion unit UE410-8DI

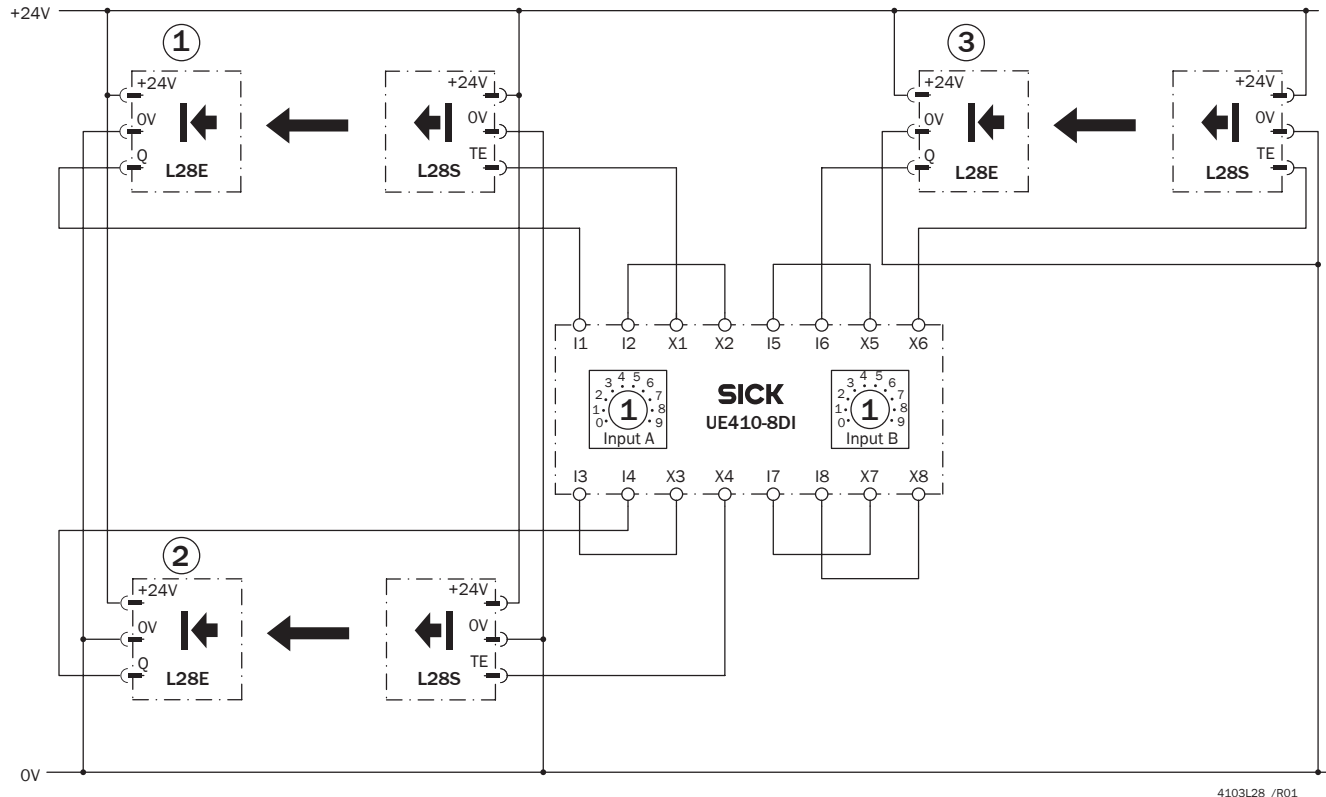

4103L28_/R01

Task

Integration of three L2000 (L28) family single-beam photoelectric safety switches in a UE410-8DI input expansion unit.

Function

The sensors switch when the light beam is clear. When sensor 1 and sensor 2 switch, input condition input A is met. If sensor 3 has switched, input condition input B is met. If a light beam is interrupted, the related input condition (input A or input B) shuts down the UE410-8DI.

Possible errors

A UE410-8DI has two test pulse generators. This means that short-circuits between odd (X1) and evenly (X2) numbered

outputs will be detected. Short-circuits between two odd (i.e. X1 and X3) or two evenly (i.e. X2 and X4) numbered outputs will not be detected. In this case short-circuits between X1 and X4 and X1 and X6 are detected, short-circuits between X4 and X6 are not detected.

Comments

Take note of the operating instructions for the devices integrated.

The safety-related parameters (safety integrity level and response time) are dependent on the types used.

Accessories

Mounting systems

Property	Delivery	Type	Part number
Mounting bracket	For L28	BEF-WN-W18	2009317

Connectors

Description	Connection type	Cable alignment	Cable length	Cable material	Type	Part number
Female connector	M12 x 4	Straight	2 m	PVC	DOL-1204-G02M	6009382
			5 m	PVC	DOL-1204-G05M	6009866
			—	—	DOS-1204-G	6007302

Deflector mirrors

Description	Mirror surface	Delivery	Type	Part number
Deflector mirrors ¹⁾	105 mm x 160 mm		PNS105-1	1004076
	75 mm x 80 mm	Including mounting adapter (two pieces swivel mount)	PNS75-008	1026647
	96 mm x 124 mm		PSK1	1005229
	—	For 90° deflection, incl. mounting set, not suitable for column mounting	PSK45	5306053
Bracket	—	For PSK 1	BEF-GH	2009292
Spring fastening	—		—	2012473

¹⁾ Reduction of the scanning range

SICK Industrial Safety Systems

Safety laser scanners and laser scanners

- S3000
- S300
- S200
- S100

Safety camera systems

- V4000 Press Brake
- V200 Work Station
- V300 Work Station

Safety light curtains

- C4000 Micro
- C4000 Basic Plus, Basic, Eco
- C4000 Standard/Advanced
- C4000 Entry/Exit
- C4000 Palletizer
- M4000 Advanced Curtain
- C2000
- LGT

Multiple light beam safety devices

- M4000 Standard
- M4000 Advanced
- M4000 Area
- M2000

Single-beam photoelectric safety switches

- L4000 System
- L4000: L41
- WSU/WEU26/2
- L2000: L21, L27, L28

SICK Industrial Safety Systems

Safety switches

- Electro-mechanical safety switches
- Non-contact safety switches
- Safety command devices

Network solutions

- UE4120, UE4150, UE4155, UE4140, UE1140
- UE4212, UE4215, UE4231, UE4232, UE4233, UE4234
- UE4420, UE4421, UE4450, UE4470
- UE4140, UE1140



Safety controllers

- UE410 Flexi
- UE440, UE470
- UE4427, UE4457
- UE4470

Safety relays

- UE10 to UE49

Software

- Safexpert

www.mysick.com

► eCatalog

► Product finder

► Applications

► and much more



www.sick.com/safetysystems

Australia

Phone +61 3 9497 4100
1800 33 48 02 – tollfree
E-Mail sales@sick.com.au

Belgium/Luxembourg

Phone +32 (0)2 466 55 66
E-Mail info@sick.be

Brasil

Phone +55 11 3215-4900
E-Mail sac@sick.com.br

Ceská Republika

Phone +420 2 57 91 18 50
E-Mail sick@sick.cz

China

Phone +852-2763 6966
E-Mail ghk@sick.com.hk

Danmark

Phone +45 45 82 64 00
E-Mail sick@sick.dk

Deutschland

Phone +49 211 5301-260
E-Mail info@sick.de

España

Phone +34 93 480 31 00
E-Mail info@sick.es

France

Phone +33 1 64 62 35 00
E-Mail info@sick.fr

Great Britain

Phone +44 (0)1727 831121
E-Mail info@sick.co.uk

India

Phone +91-22-4033 8333
E-Mail info@sick-india.com

Israel

Phone +972-4-999-0590
E-Mail info@sick-sensors.com

Italia

Phone +39 02 27 43 41
E-Mail info@sick.it

Japan

Phone +81 (0)3 3358 1341
E-Mail support@sick.jp

Nederlands

Phone +31 (0)30 229 25 44
E-Mail info@sick.nl

Norge

Phone +47 67 81 50 00
E-Mail austefjord@sick.no

Österreich

Phone +43 (0)22 36 62 28 8-0
E-Mail office@sick.at

Polska

Phone +48 22 837 40 50
E-Mail info@sick.pl

Republic of Korea

Phone +82-2 786 6321/4
E-Mail kang@sickkorea.net

Republika Slovenija

Phone +386 (0)1-47 69 990
E-Mail office@sick.si

România

Phone +40 356 171 120
E-Mail office@sick.ro

Russia

Phone +7 495 775 05 34
E-Mail info@sick-automation.ru

Schweiz

Phone +41 41 619 29 39
E-Mail contact@sick.ch

Singapore

Phone +65 6744 3732
E-Mail admin@sicksgp.com.sg

Suomi

Phone +358-9-25 15 800
E-Mail sick@sick.fi

Sverige

Phone +46 10 110 10 00
E-Mail info@sick.se

Taiwan

Phone +886 2 2375-6288
E-Mail sickgrc@ms6.hinet.net

Türkiye

Phone +90 216 587 74 00
E-Mail info@sick.com.tr

USA/Canada/México

Phone +1(952) 941-6780
1 800-325-7425 – tollfree
E-Mail info@sickusa.com

More representatives and agencies
in all major industrial nations at
www.sick.com