

Harmony XB5R

Expert Instruction Sheet

04/2011

EIO0000000812.01

www.schneider-electric.com

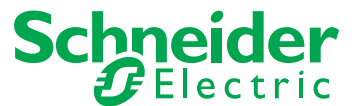

The information provided in this documentation contains general descriptions and/or technical characteristics of the performance of the products contained herein. This documentation is not intended as a substitute for and is not to be used for determining suitability or reliability of these products for specific user applications. It is the duty of any such user or integrator to perform the appropriate and complete risk analysis, evaluation and testing of the products with respect to the relevant specific application or use thereof. Neither Schneider Electric nor any of its affiliates or subsidiaries shall be responsible or liable for misuse of the information contained herein. If you have any suggestions for improvements or amendments or have found errors in this publication, please notify us.

No part of this document may be reproduced in any form or by any means, electronic or mechanical, including photocopying, without express written permission of Schneider Electric.

All pertinent state, regional, and local safety regulations must be observed when installing and using this product. For reasons of safety and to help ensure compliance with documented system data, only the manufacturer should perform repairs to components.

When devices are used for applications with technical safety requirements, the relevant instructions must be followed.

Failure to use Schneider Electric software or approved software with our hardware products may result in injury, harm, or improper operating results.

Failure to observe this information can result in injury or equipment damage.

© 2011 Schneider Electric. All rights reserved.

Table of Contents



	Safety Information	5
	About the Book	7
Chapter 1	Harmony XB5R Introduction	9
	General Presentation of Harmony XB5R	10
	Presentation of Harmony XB5R Ready to Use Packages	12
	Presentation of XB5R Components	14
Chapter 2	Installation	19
	General Installation Instruction for Harmony XB5R	20
	Transmitter and Pushbutton Assembly	24
	Transmitter and Pushbutton Disassembly	27
	Receiver Assembly and Disassembly	29
	Receiver Wiring Diagram	32
	Relay Antenna Installation	34
	Mounting Instructions for Mobile Box	38
Chapter 3	Preparing For Use	41
	LED Status	42
	Output mode: Monostable - Bistable - Stop/Start	43
	Changing outputs from Monostable to Bistable for XB•RFA02, XB5RMA04, ZBRRRA	47
	Changing Outputs From Monostable to Stop/Start for XB•RFA02, XB5RMA04, ZBRRRA	49
	How to Teach/Unteach Monostable or Bistable Outputs for XB•RFA02, XB5RMA04, ZBRRRA, ZBRRC	51
	How to Teach Stop/Start Outputs for XB•RFA02, XB5RMA04, ZBRRRA ..	55
	Lock/Unlock for XB•RFA02, XB5RMA04, ZBRRRA, ZBRRC	60
Chapter 4	Other Functions for Harmony XB5R	63
	Other Functions Description	63

Safety Information

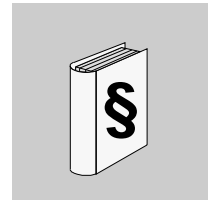

Important Information

NOTICE

Read these instructions carefully, and look at the equipment to become familiar with the device before trying to install, operate, or maintain it. The following special messages may appear throughout this documentation or on the equipment to warn of potential hazards or to call attention to information that clarifies or simplifies a procedure.



The addition of this symbol to a Danger or Warning safety label indicates that an electrical hazard exists, which will result in personal injury if the instructions are not followed.



This is the safety alert symbol. It is used to alert you to potential personal injury hazards. Obey all safety messages that follow this symbol to avoid possible injury or death.

DANGER

DANGER indicates an imminently hazardous situation which, if not avoided, **will result in** death or serious injury.

WARNING

WARNING indicates a potentially hazardous situation which, if not avoided, **can result in** death or serious injury.

 **CAUTION**

CAUTION indicates a potentially hazardous situation which, if not avoided, **can result in** minor or moderate injury.

CAUTION

CAUTION, used without the safety alert symbol, indicates a potentially hazardous situation which, if not avoided, **can result in** equipment damage.

PLEASE NOTE

Electrical equipment should be installed, operated, serviced, and maintained only by qualified personnel. No responsibility is assumed by Schneider Electric for any consequences arising out of the use of this material.

A qualified person is one who has skills and knowledge related to the construction and operation of electrical equipment and its installation, and has received safety training to recognize and avoid the hazards involved.

About the Book

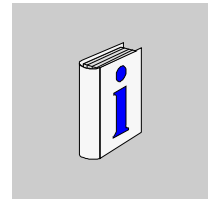

At a Glance

Document Scope

This documentation is a reference for the Harmony XB5R wireless and batteryless pushbutton.

Validity Note

This documentation is valid for Harmony XB5R.

The technical characteristics of the device(s) described in this manual also appear online. To access this information online:

Step	Action
1	Go to the Schneider Electric home page www.schneider-electric.com .
2	In the Search box type the model number of a product or the name of a product range. <ul style="list-style-type: none">● Do not include blank spaces in the model number/product range.● To get information on a grouping similar modules, use asterisks (*).
3	If you entered a model number, go to the Product datasheets search results and click on the model number that interests you. If you entered the name of a product range, go to the Product Ranges search results and click on the product range that interests you.
4	If more than one model number appears in the Products search results, click on the model number that interests you.
5	Depending on the size of your screen, you may need to scroll down to see the data sheet.
6	To save or print a data sheet as a .pdf file, click Download XXX product datasheet .

The characteristics presented in this manual should be the same as those that appear online. In line with our policy of constant improvement we may revise content over time to improve clarity and accuracy. In the event that you see a difference between the manual and online information, use the online information as your reference.

Related Documents

Title of Documentation	Reference Number
Wireless and Batteryless Pushbutton Catalogue Module	36174
Package Instruction Sheet	S1A57199
Receivers Instruction Sheet	S1A57202
Transmitter with Metal or Plastic Head and Cap Instruction Sheet	S1A57198
Relay Antenna Instruction Sheet	S1A57194
Mobile Box Instruction Sheet	S1A57210

You can download these technical publications and other technical information from our website at www.schneider-electric.com.

Product Related Information

The application of this product requires expertise in the design and programming of control systems.

 WARNING
UNINTENDED EQUIPMENT OPERATION Only persons with expertise in the design and programming of control systems are allowed to program, install, alter, and apply this product. Follow all local and national safety codes and standards. Failure to follow these instructions can result in death, serious injury, or equipment damage.

User Comments

We welcome your comments about this document. You can reach us by e-mail at techcomm@schneider-electric.com.

Harmony XB5R Introduction



1

Purpose

This chapter provides an overview of the Harmony XB5R.

What's in this Chapter?

This chapter contains the following topics:

Topic	Page
General Presentation of Harmony XB5R	10
Presentation of Harmony XB5R Ready to Use Packages	12
Presentation of XB5R Components	14

General Presentation of Harmony XB5R

Offer Presentation

Harmony wireless and batteryless pushbuttons are used for remote control of a receiver relay using a transmitter pushbutton. Control is via radio transmission: the transmitter is equipped with a “dynamo” generator that converts the mechanical energy produced by pressing the pushbutton into electrical energy. A radio-coded message with a unique ID code is sent, in a single pulse, to one or more receiver(s) located several tens of metres away (see figure A). One receiver can also be activated by different transmitters (see figure B).

This technology cannot be used for hoisting applications (“raise/lower”, “left/right”, etc. movements) or safety applications (emergency stop buttons etc.). The Harmony XB4 and XB5 wired pushbutton range or the XAC pendant control station range have to be used for these applications.

WARNING

UNINTENDED EQUIPMENT OPERATION

- Do not use this equipment in safety critical machine functions.
- Use appropriate safety interlocks where personnel and/or equipment hazards exist.
- Do not disassemble, repair, or modify this equipment.
- Install and operate this equipment in an appropriately rated enclosure for its intended environment.
- Install properly rated fuses.
- Check that the control is not activated if the product falls during transit.

Failure to follow these instructions can result in death, serious injury, or equipment damage.

NOTE: The rated fuses are indicated in the Receiver Wiring Diagram (*see page 32*).

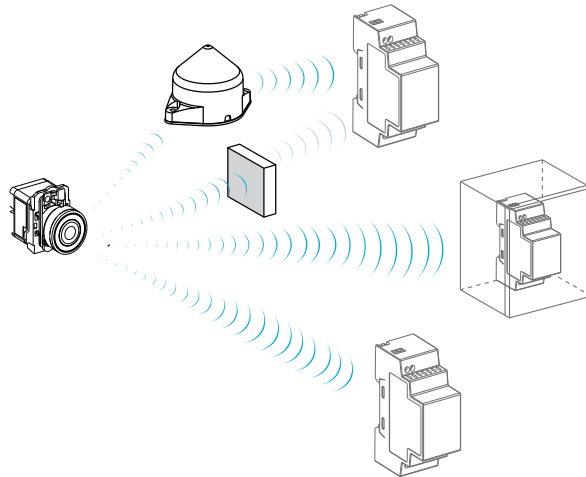
Figure A: Transmission between 1 Transmitter and 3 Receivers

NOTE: One transmitter can be taught and can activate several receivers. The number of receivers is not limited.

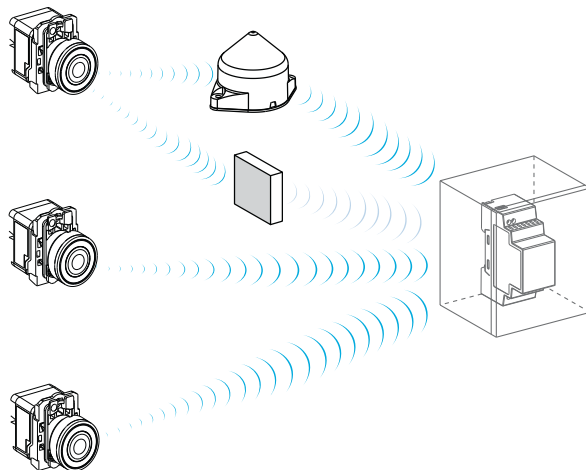
Figure B: Transmission between 3 Transmitters and 1 Receiver

NOTE: One receiver can be activated by several transmitters. The number of transmitters is limited: 32 transmitters maximum.

Presentation of Harmony XB5R Ready to Use Packages

Illustration

NOTE: The following figures show for all packages, the transmitter and the receiver are already paired in Schneider factory.

XB•RFB01

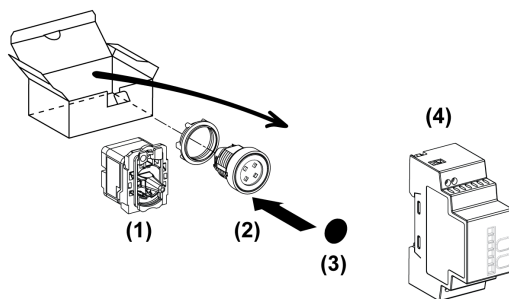

XB•RFA02

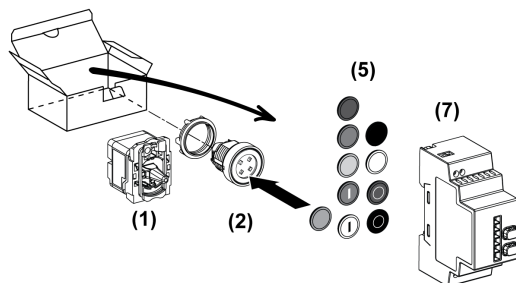

XB5RMB03

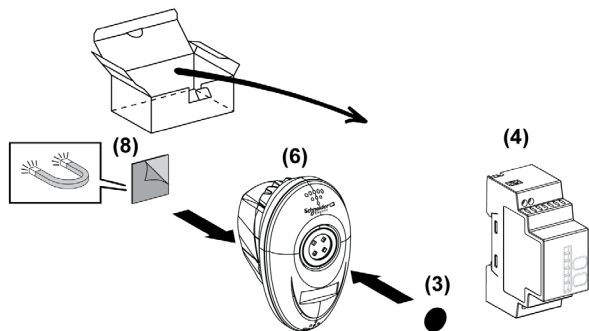

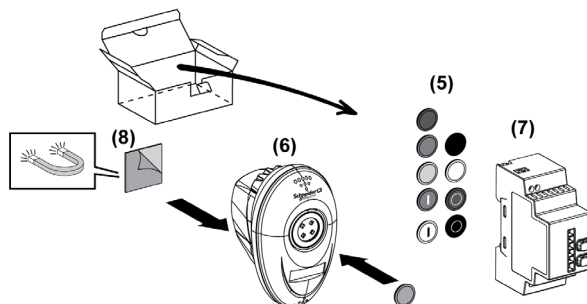
XB5RMA04

- 1 Transmitter
- 2 Head
- 3 Cap
- 4 Non-programmable receiver
- 5 Set of 10 caps
- 6 Transmitter + Head + Mobile box
- 7 Programmable receiver
- 8 Magnet (could be glued on the box if needed)

⚠ DANGER

HAZARD OF ELECTRIC SHOCK, EXPLOSION OR ARC FLASH

- Disconnect all power before servicing equipment.
- Use only the specified voltage when operating this equipment and any associated products.

Failure to follow these instructions will result in death or serious injury.

Presentation of XB5R Components

Transmitters



The following table describes the transmitter characteristics.

Designation	Pushbutton Type	Cap color	Reference	Mass
Transmitter Only	-	-	ZBRT1	0.025 kg (0.055 lb)
Pushbutton for transmitter ZBRT1	Plastic	Without cap	ZB5RZA0	0.015 kg (0.033 lb)
	Metallic	Without cap	ZB4RZA0	0.030 kg (0.066 lb)

Designation	Pushbutton Type	Cap color	Reference	Mass	
Complete transmitters including: - Transmitter with mounting base - Pushbutton - Cap mounted	Plastic	White	ZB5RTA1	0.045 kg (0.099 lb)	
		Black	ZB5RTA2	0.045 kg (0.099 lb)	
		Green	ZB5RTA3	0.045 kg (0.099 lb)	
		"I" white on green background	ZB5RTA331	0.045 kg (0.099 lb)	
		Red	ZB5RTA4	0.045 kg (0.099 lb)	
		"O" White on red background	ZB5RTA432	0.045 kg (0.099 lb)	
		Yellow	ZB5RTA5	0.045 kg (0.099 lb)	
		Blue	ZB5RTA6	0.045 kg (0.099 lb)	
	Metallic	White	ZB4RTA1	0.085 kg (0.187 lb)	
			Black	ZB4RTA2	0.085 kg (0.187 lb)
			Green	ZB4RTA3	0.085 kg (0.187 lb)
			"I" White on green background	ZB4RTA331	0.085 kg (0.187 lb)
			Red	ZB4RTA4	0.085 kg (0.187 lb)
			"O" White on red background	ZB4RTA432	0.085 kg (0.187 lb)
			Yellow	ZB4RTA5	0.085 kg (0.187 lb)
Blue			ZB4RTA6	0.085 kg (0.187 lb)	

Programmable Receivers

The following figure shows the programmable receivers:

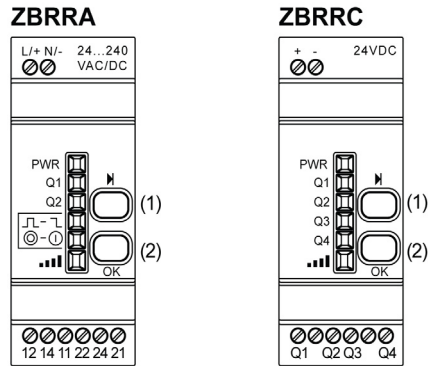

- (1): Selection button
- (2): Validation button

The following table describes the characteristics of programable receivers:

Designation	Ouputs	Receiver Voltage	Reference	Mass
Programmable Receivers with indicator light LED and teach button	4 PNP 200 mA	24 Vdc	ZBRRC	0.130 kg (0.286 lb)
	2 relays change over 3 A	24...240 Vac/Vdc	ZBRRRA	0.130 kg (0.286 lb)

Harmony ZB5RZA0 and ZB4RZA0 Pushbutton Caps



ZBA7235



ZBA7331



ZBA7432

The following table describes the characteristics of the caps for the ZB5RZA0 and ZB4RZA0 pushbuttons.

Cap Color	Labeling	Reference	Mass
White	-	ZBA71	0.010 kg (0.022 lb)
	"I" black	ZBA7137	0.010 kg (0.022 lb)
	"↑" black	ZBA7134	0.010 kg (0.022 lb)
	"+" black	ZBA7138	0.010 kg (0.022 lb)
Black	-	ZBA72	0.010 kg (0.022 lb)
	"O" white	ZBA7232	0.010 kg (0.022 lb)
	"+" white	ZBA7233	0.010 kg (0.022 lb)
	"↓" white	ZBA7235	0.010 kg (0.022 lb)
	"I" white	ZBA7237	0.010 kg (0.022 lb)
Green	-	ZBA73	0.010 kg (0.022 lb)
	"I" white	ZBA7331	0.010 kg (0.022 lb)
	"+" white	ZBA7333	0.010 kg (0.022 lb)
	"↑" white	ZBA7335	0.010 kg (0.022 lb)
	"II" white	ZBA7336	0.010 kg (0.022 lb)
Red	-	ZBA74	0.010 kg (0.022 lb)
	"O" white	ZBA7432	0.010 kg (0.022 lb)
Yellow	-	ZBA75	0.010 kg (0.022 lb)
Blue	-	ZBA76	0.010 kg (0.022 lb)

Accessories

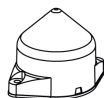

ZBRA1

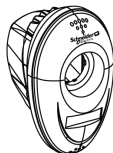

ZBRM01



ZB5AZ009



XALD02

The following table describes the characteristics of housing and accessories for XB5R.

Designation	Description	Reference	Mass
Empty plastic box for mobile transmitter	1 hole	ZBRM01	0.09 kg (1.984 lb)
Empty plastic box for embedded or fixed transmitter	1 hole	XALD01	0.136 kg (0.299 lb)
	2 holes	XALD02	0.193 kg (0.425 lb)
Relay-Antenna for increased distances	24...240 Vac/Vdc - Cable (5 m/16.4 ft) - 1 Voltage LED - 2 Reception/Emission LED	ZBRA1	0.200 kg (0.440 lb)
Mounting Base	Plastic	ZB5AZ009	0.006 kg (0.013 lb)
	Metallic	ZB4BZ009	0.038 kg (0.083 lb)

Installation

2

Purpose

This chapter provides an overview of the Harmony XB5R installation.

What's in this Chapter?

This chapter contains the following topics:

Topic	Page
General Installation Instruction for Harmony XB5R	20
Transmitter and Pushbutton Assembly	24
Transmitter and Pushbutton Disassembly	27
Receiver Assembly and Disassembly	29
Receiver Wiring Diagram	32
Relay Antenna Installation	34
Mounting Instructions for Mobile Box	38

General Installation Instruction for Harmony XB5R

Maximum Distances

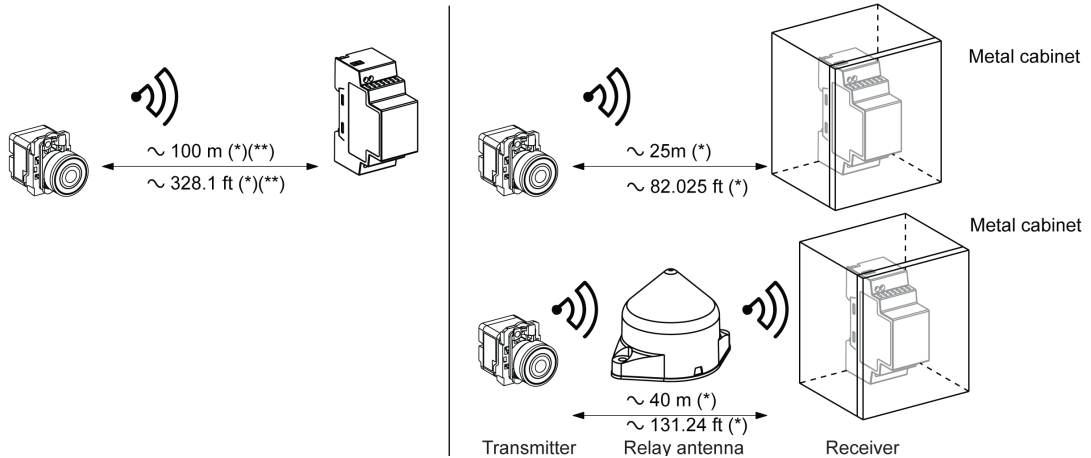

(*) Typical values that may be modified by the application environment.

(**) Free field (unobstructed).

NOTE:

- The range may be increased by adding antenna ZBRA1.
- The range is reduced if the transmitter is placed in a metal box (reduction factor: approx 10%).
- Once wiring is complete, test the product in all possible active areas (while remaining within range).

The level of signal attenuation depends on the materials through which the signal will pass:

Glass window	10...20 % (*)
Plaster wall	30...45 % (*)
Brick wall	60 % (*)
Concrete wall	70...80 % (*)
Metal structure	50...100 % (*)

(*) Values for indication purposes only. Actual values depend on the thickness and nature of the material.

Installation Conditions

Transmitter operating temperature	-25...+70°C (-13...+158°F)
Receiver operating temperature	-25...+55°C (-13...+131°F)
Transmitter protection level	IP65
Receiver protection level	IP20
Transmitter shock resistance	IK03

Mounting Tips

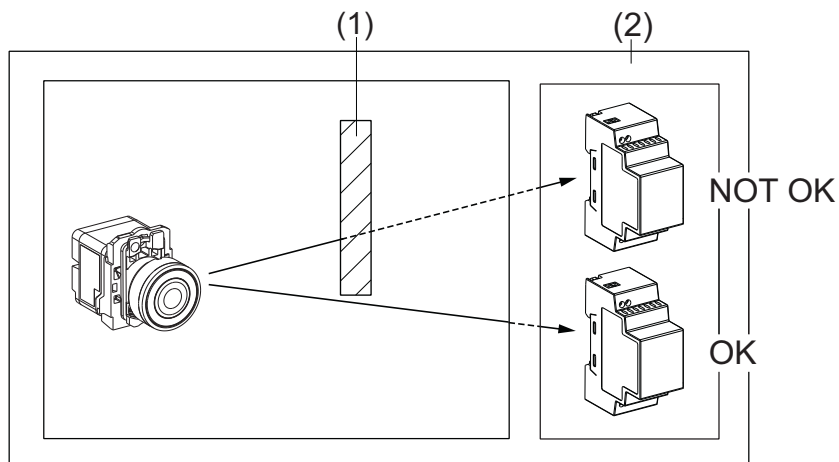

1 Metal structure

2 Wall

NOTE: To ease the radio transmission, the best is to avoid obstacles. Find the best place to install the transmitter and the receiver to have the minimum of obstacles.

Mounting Tips for Antenna

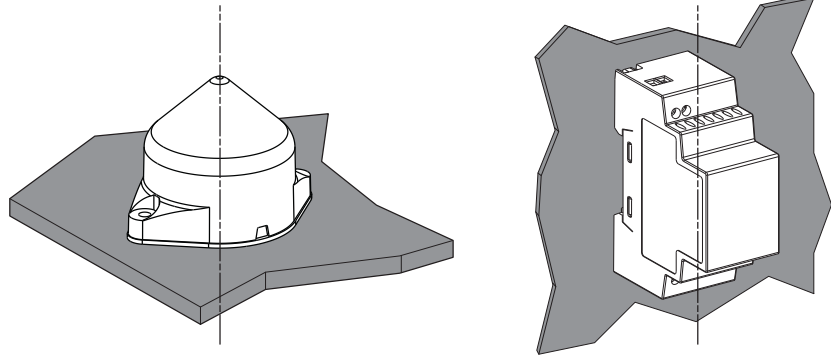

The antenna and the receiver are installed following their vertical axis.

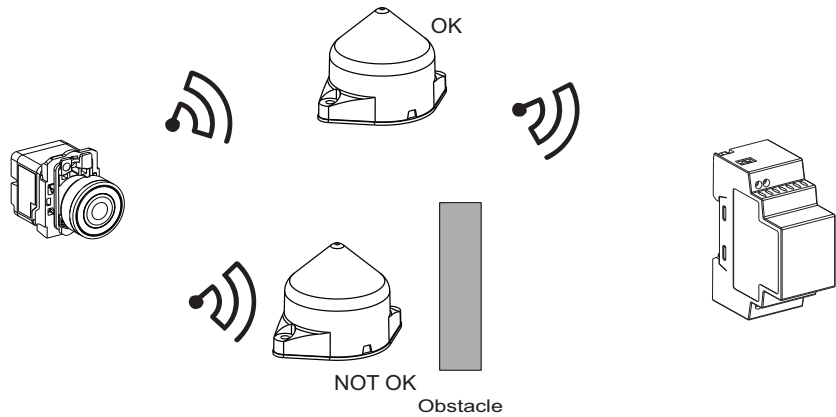

The antenna is used to bypass the obstacle.

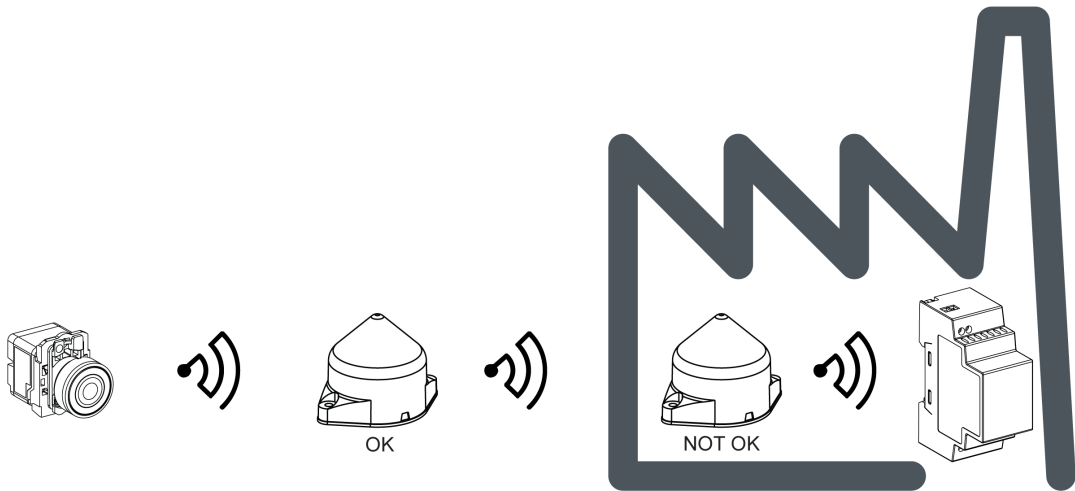

NOTE: The antenna should be placed before the obstacle. The signal will be amplified before the obstacle to enable to go through it.

Transmitter and Pushbutton Assembly

Introduction

Follow these steps to install the transmitter and pushbutton.

Step 1: Mounting on a panel

This figure shows the diameter of the holes for ZB5R or ZB4R pushbuttons.

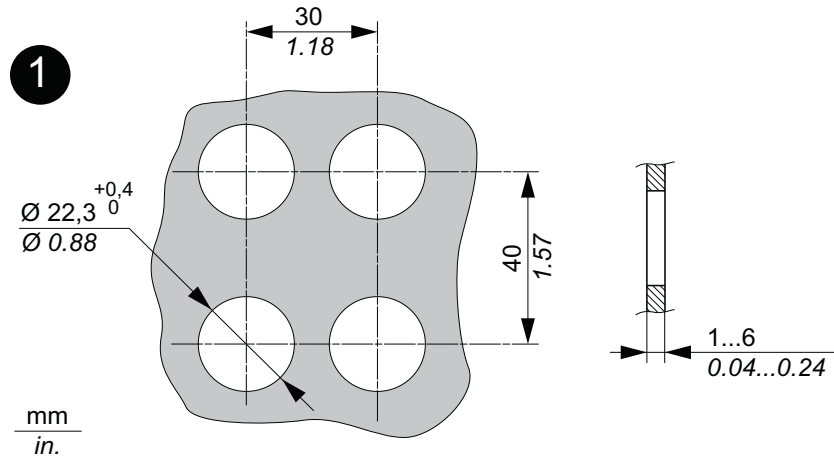

Step 2: Attach the mounting base to the transmitter

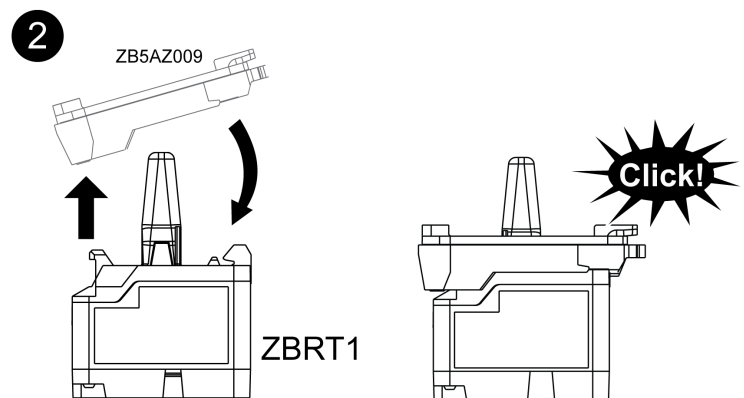

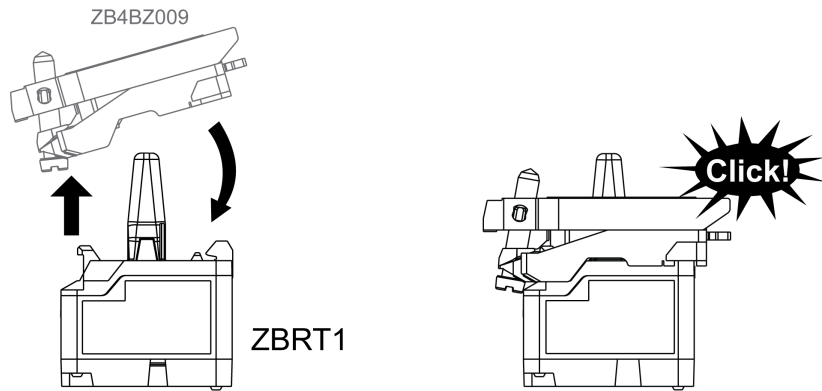

Packages: ID Registration

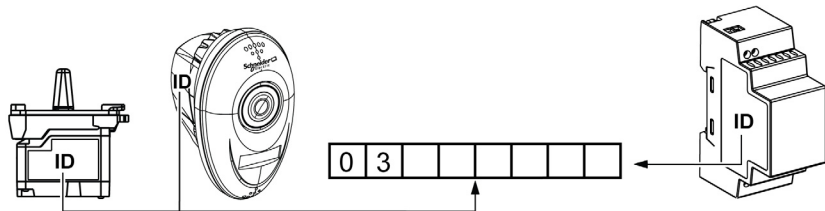

NOTE: Please note and retain your transmitter ID. You will need it for an ID reset. The ID reset is described in the Total Reset and ID Reset Procedure (*see page 63*).

Transmitter: ID Registration

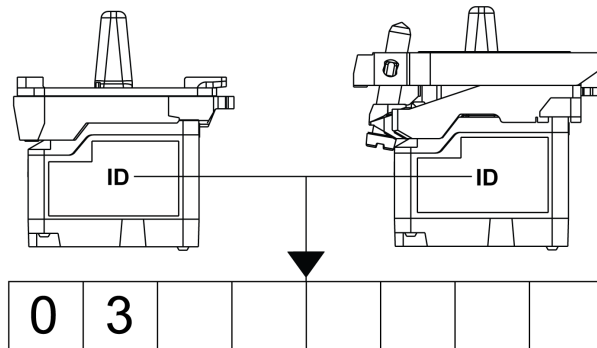

Steps 3, 4 and 5: Assembling Plastic Pushbuttons

Plastic pushbuttons are assembled as follows:

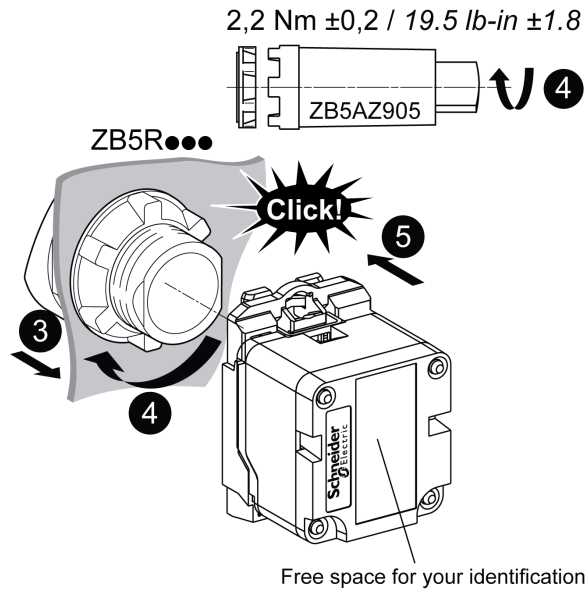

Steps 3, 4 and 5: Assembling Metallic Pushbuttons

Metallic pushbuttons are assembled as follows:

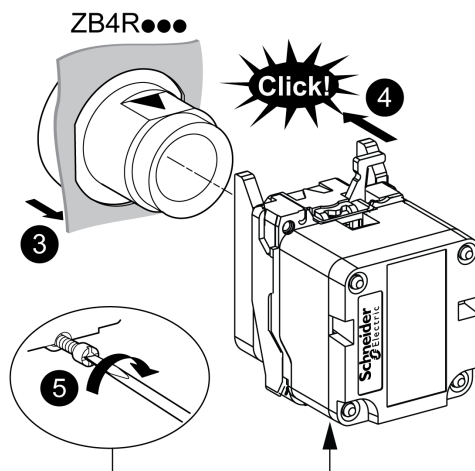

Transmitter and Pushbutton Disassembly

Plastic Pushbutton Disassembling

Follow the four steps shown to disassemble the transmitter and the plastic pushbutton:

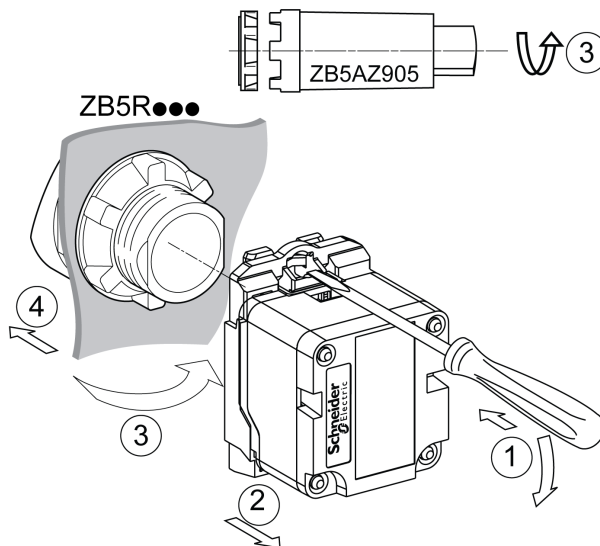

Metallic Pushbutton Disassembling

Follow the three steps shown to disassemble the transmitter and the metallic pushbutton:

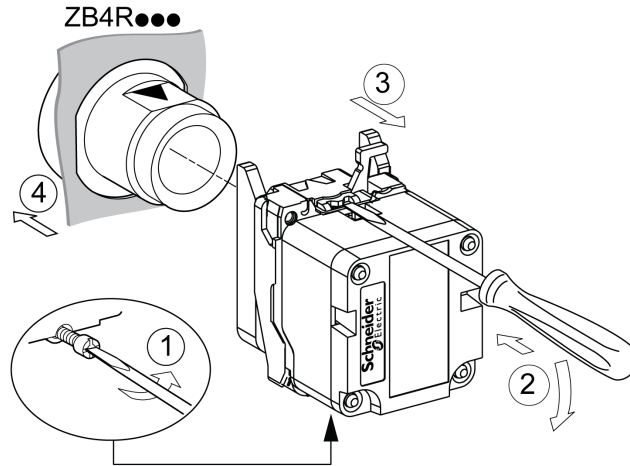

Models: ZBRT1 and ZBRTTP

FCC USA and I C Canada Compliance Statement

This device complies with part 15 of the FCC rules and Industry Canada licence-exempt RSS standard(s). Operation is subject to the following two conditions:

- 1) This device may not cause harmful interference.
- 2) This device must accept any interference received, including interference that may cause undesired operation of the device.

NOTE: Schneider Electric is not responsible for any radio or tv interference caused by unauthorized modifications to this equipment. Changes or modifications not expressly approved by Schneider Electric responsible for compliance could void the user's authority to operate the equipment.

Le présent appareil est conforme aux CNR d'Industrie Canada applicables aux appareils radio exempts de licence. L'exploitation est autorisée aux deux conditions suivantes:

- 1) L'appareil ne doit pas produire de brouillage.
- 2) L'utilisateur de l'appareil doit accepter tout brouillage radioélectrique subi, même si le brouillage est susceptible d'en compromettre le fonctionnement.

Receiver Assembly and Disassembly

Instructions

Follow the steps in black for assembly.

Follow the steps in white for disassembly.

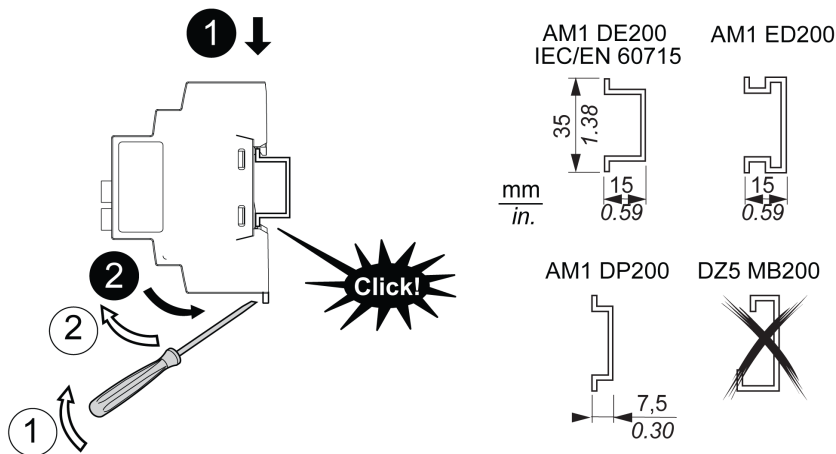

Models: ZBRRA, ZBRRC, XB•RFB01

FCC USA and I C Canada Compliance Statement

This device complies with part 15 of the FCC rules and Industry Canada licence-exempt RSS standard(s). Operation is subject to the following two conditions:

- 1) This device may not cause harmful interference.
- 2) This device must accept any interference received, including interference that may cause undesired operation of the device.

NOTE: Schneider Electric is not responsible for any radio or tv interference caused by unauthorized modifications to this equipment. Changes or modifications not expressly approved by Schneider Electric responsible for compliance could void the user's authority to operate the equipment.

Le présent appareil est conforme aux CNR d'Industrie Canada applicables aux appareils radio exempts de licence. L'exploitation est autorisée aux deux conditions suivantes:

- 1) L'appareil ne doit pas produire de brouillage.
- 2) L'utilisateur de l'appareil doit accepter tout brouillage radioélectrique subi, même si le brouillage est susceptible d'en compromettre le fonctionnement.

In USA, our address and contact:

Schneider Electric
 8001 Knightdale Blvd,
 Knightdale, NC 27545
 919-266-3671 (phone)

Receiver Dimensions

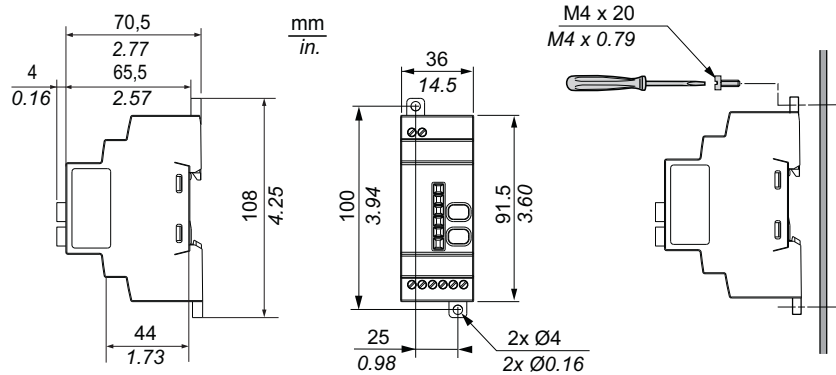

$\frac{\text{mm}}{\text{in.}}$	6 0.24				
mm ²		0,14...0,75	0,14...2,5	0,14...4	0,14...1,5
AWG		26...18	26...14	26...12	26...16

		Nm	0,6
Ø 3,5 mm / 0.14 in.		lb-in	5.3

Receiver Mounting Positions

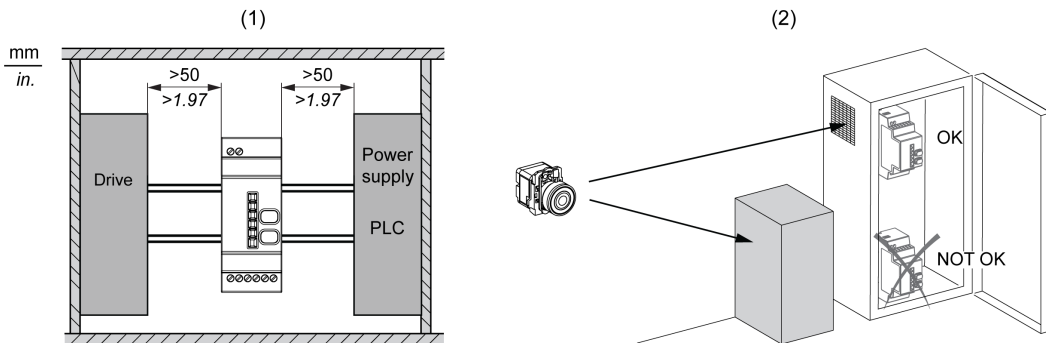

(1): To enhance the signal reception, respect the above positioning.

(2): In a metal cabinet, the optimum place for the receiver is on the top and/or near the holes. This position avoids obstacles and enhances reception.

NOTE: For XB•RFA02, XB5RMA04, ZBRRRA, ZBRRRC: before disassembly for storage, perform a total reset of the receiver memory. The total reset is described in the Total Reset and ID Reset procedure (*see page 63*).

Receiver Wiring Diagram

Wiring Diagram

The following figures show the wiring diagrams for the Harmony XB5R Receiver.

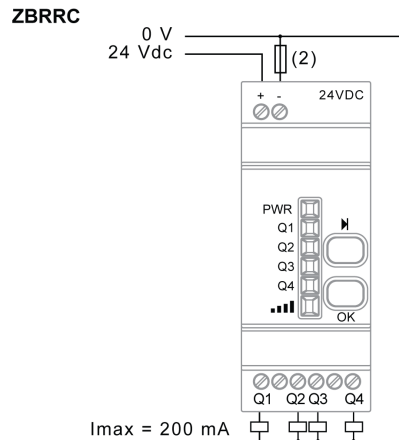
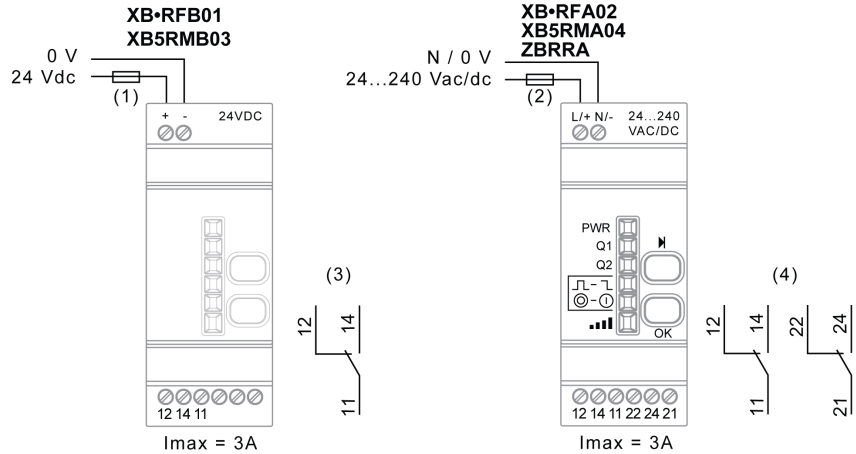

- (1): 125 mA fast-blow fuse.
- (2): 500 mA fuse from supplier BUSSMAN reference GMA-500 mA, 250 V 0.5 A fast-blow.
- (3): Output contact ratings B300 Pilot Duty 3 A - 240 Vac Resistive.
- (4): Output contact ratings B300 - R300 Pilot Duty 3 A - 240 Vac Resistive.

UL: Control of overvoltage to be provided after main service disconnect overcurrent device, with a UL1449 TVSS device (Transient Voltage Surge Suppressor) tested as type 2 (6kV/3kA min), with a MCOV (Maximum Continuous Operating Voltage) min rated to Phase to Phase voltage and a VPR (Voltage Protection Rating) of 1.5 kV.

 **DANGER****HAZARD OF ELECTRIC SHOCK, EXPLOSION OR ARC FLASH**

- Disconnect all power before servicing equipment.
- Use only the specified voltage when operating this equipment and any associated products.

Failure to follow these instructions will result in death or serious injury.

Relay Antenna Installation

Introduction

Observe the maximum distances between transmitter, antenna and receiver (*see page 20*) and the Mounting tips for antenna (*see page 22*).

Temporary Mounting

This temporary mounting is used to search the best place for the antenna in order to enhance the radio signal.

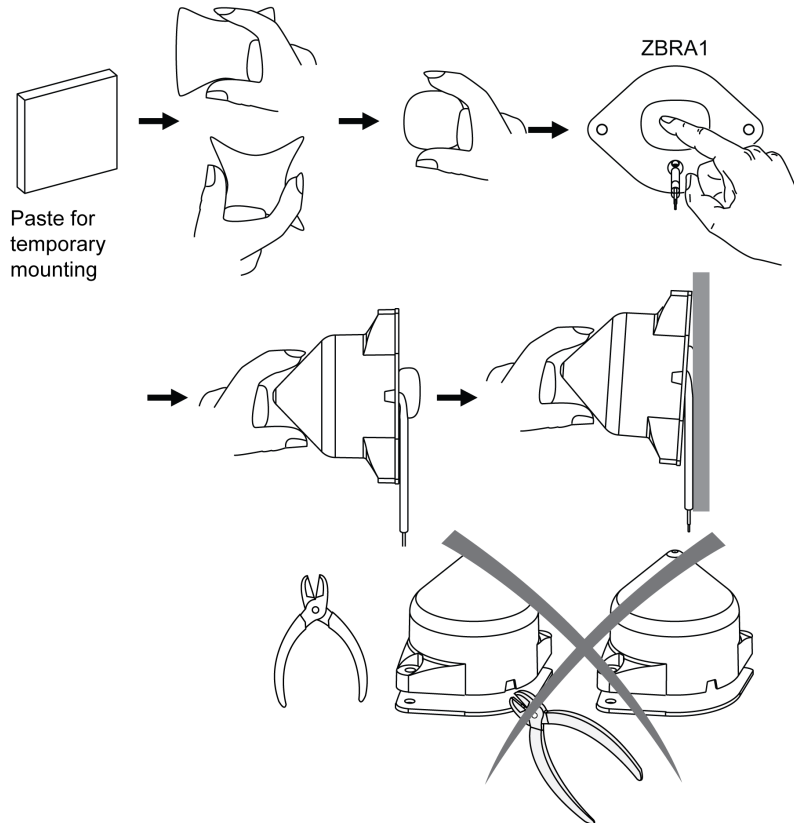

NOTE: For temporary assembly the breakable part of the antenna must not be cut off.

Axial Cable Route

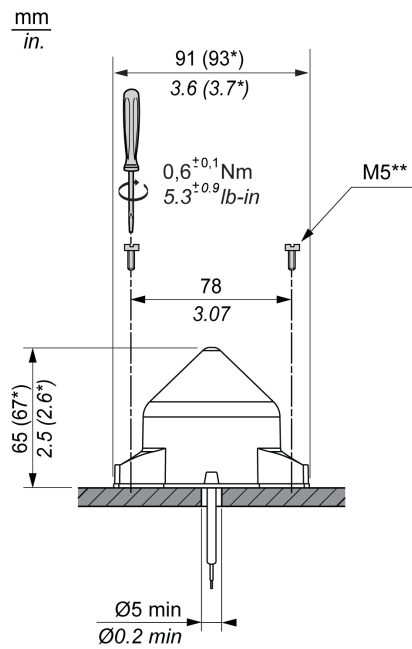

*: dimensions including gasket

** : Screws not supplied

Radial Cable Route

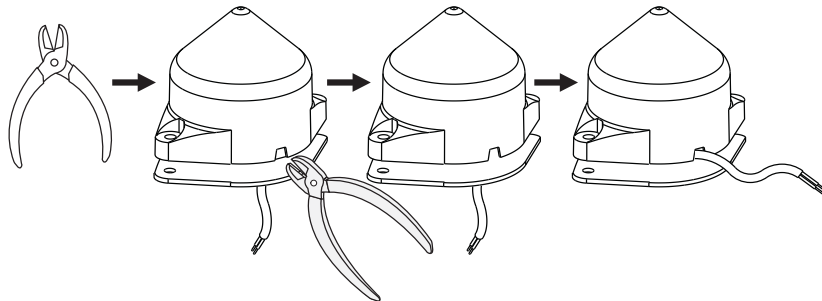

Wiring Diagram

The following figure shows the relay antenna wiring diagram for Harmony XB5R:

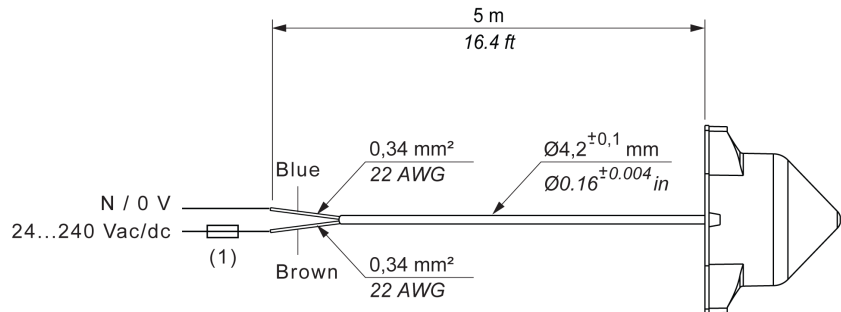

(1): 500 mA from supplier BUSSMAN reference GMA-500mA, 250 V 0.5 A fast-blow.

UL: Control of Overvoltage to be provided after main service disconnect overcurrent device, with a UL1449 TVSS device (Transient Voltage Surge Suppressor) Tested as type 2 (6 kV/3 kA min), with a MCOV (Maximum Continuous Operating Voltage) min. rated to Phase to Phase voltage and a VPR (Voltage Protection Rating) of 1.5 kV.

⚠ WARNING

UNINTENDED EQUIPMENT OPERATION

- Do not use this equipment in safety critical machine functions.
- Use appropriate safety interlocks where personnel and/or equipment hazards exist.
- Install and operate this equipment in an enclosure appropriately rated for its intended environment.

Failure to follow these instructions can result in death, serious injury, or equipment damage.

Model: ZBRA1**FCC USA and I C Canada Compliance Statement**

This device complies with part 15 of the FCC rules and Industry Canada licence-exempt RSS standard(s). Operation is subject to the following two conditions:

- 1) This device may not cause harmful interference.
- 2) This device must accept any interference received, including interference that may cause undesired operation of the device.

NOTE: Schneider Electric is not responsible for any radio or tv interference caused by unauthorized modifications to this equipment. Changes or modifications not expressly approved by Schneider Electric responsible for compliance could void the user's authority to operate the equipment.

Le présent appareil est conforme aux CNR d'Industrie Canada applicables aux appareils radio exempts de licence. L'exploitation est autorisée aux deux conditions suivantes:

- 1) L'appareil ne doit pas produire de brouillage.
- 2) L'utilisateur de l'appareil doit accepter tout brouillage radioélectrique subi, même si le brouillage est susceptible d'en compromettre le fonctionnement.

Mounting Instructions for Mobile Box

Assembly Mobile Box

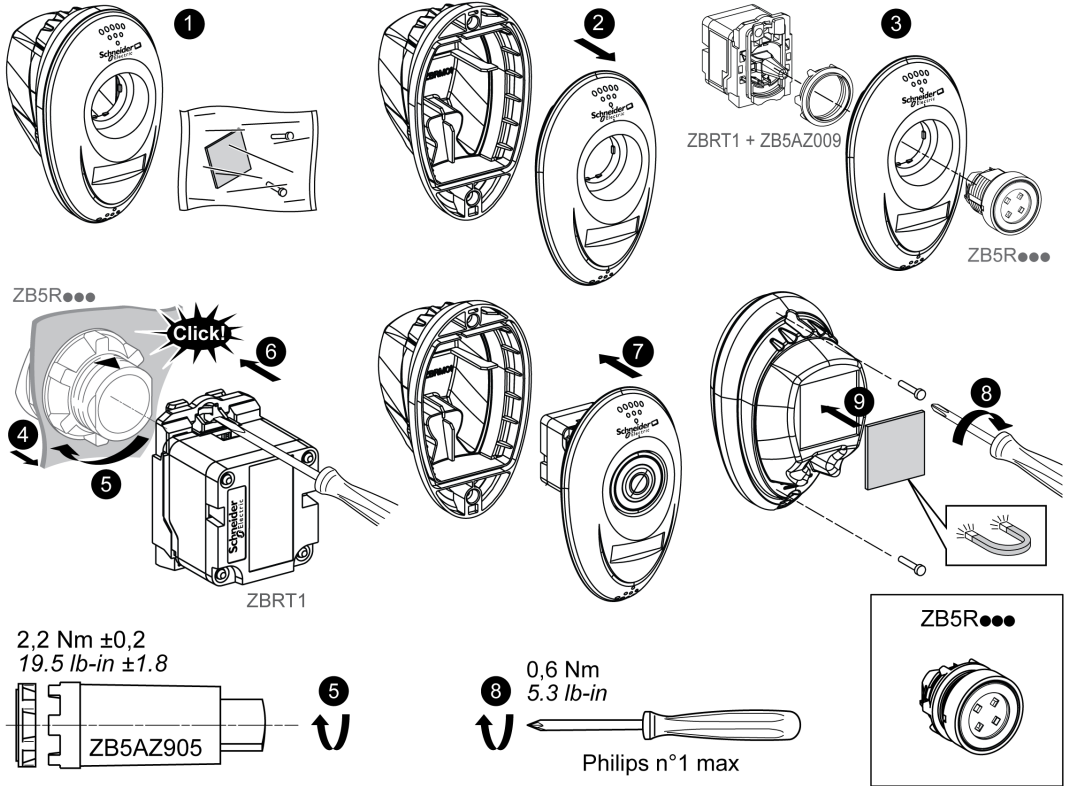

Disassembly

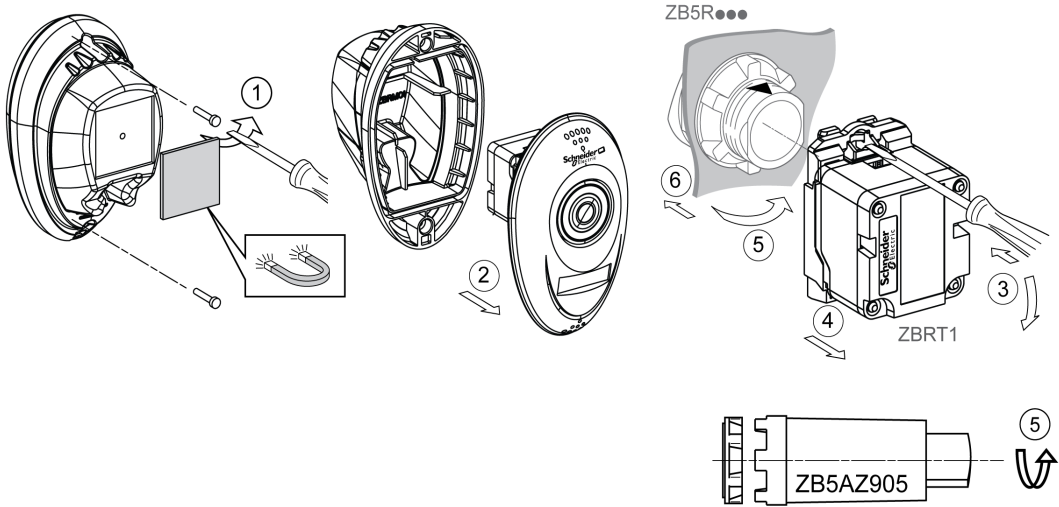

Location for Accessories

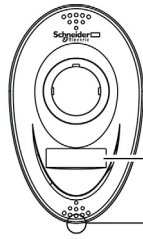

Free space for your identification
ZBY0101T 8 x 27 mm (0.31 x 1.06 in.)

Place for neck lanyard

Preparing For Use

3

Purpose

This chapter explains how to prepare the Harmony XB5R for use.

What's in this Chapter?

This chapter contains the following topics:

Topic	Page
LED Status	42
Output mode: Monostable - Bistable - Stop/Start	43
Changing outputs from Monostable to Bistable for XB•RFA02, XB5RMA04, ZBRRRA	47
Changing Outputs From Monostable to Stop/Start for XB•RFA02, XB5RMA04, ZBRRRA	49
How to Teach/Unteach Monostable or Bistable Outputs for XB•RFA02, XB5RMA04, ZBRRRA, ZBRRRC	51
How to Teach Stop/Start Outputs for XB•RFA02, XB5RMA04, ZBRRRA	55
Lock/Unlock for XB•RFA02, XB5RMA04, ZBRRRA, ZBRRRC	60

LED Status

XB•RFA02 / XB5RMA04 and ZBRRRA

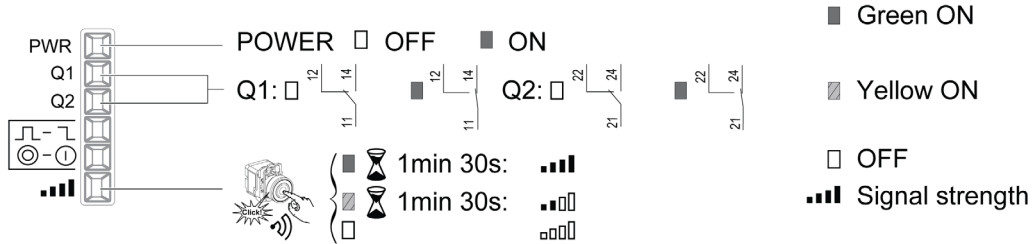

ZBRRC

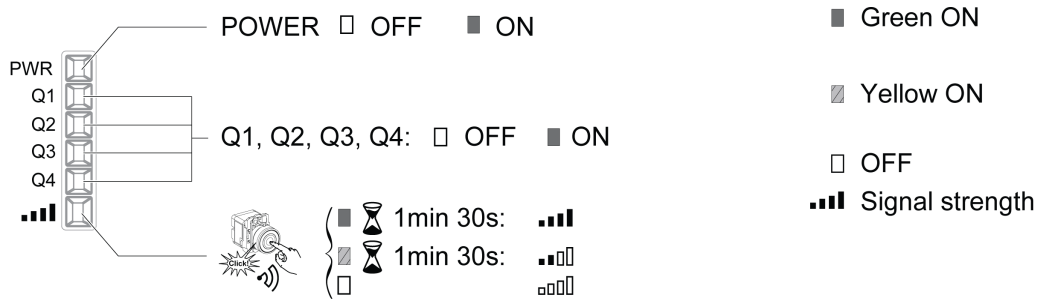

NOTE: The signal strength LED indicates the value of the last signal received. The time out for the LED is 1 min 30s. This LED could also be switched off by pressing once the selection button of the receiver.

Synthesis

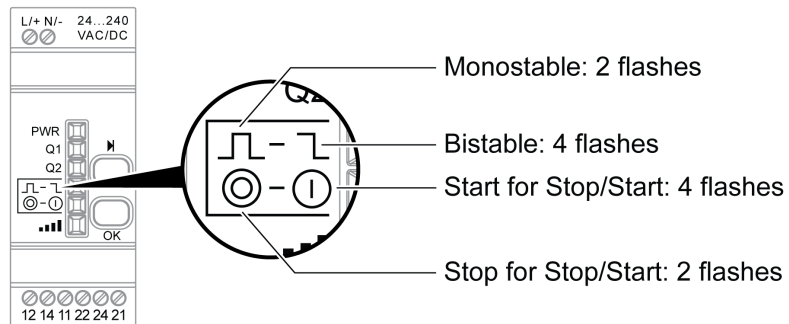

Output mode: Monostable - Bistable - Stop/Start

Monostable Output: Factory setting for packages and for ZBRRA and ZBRRC

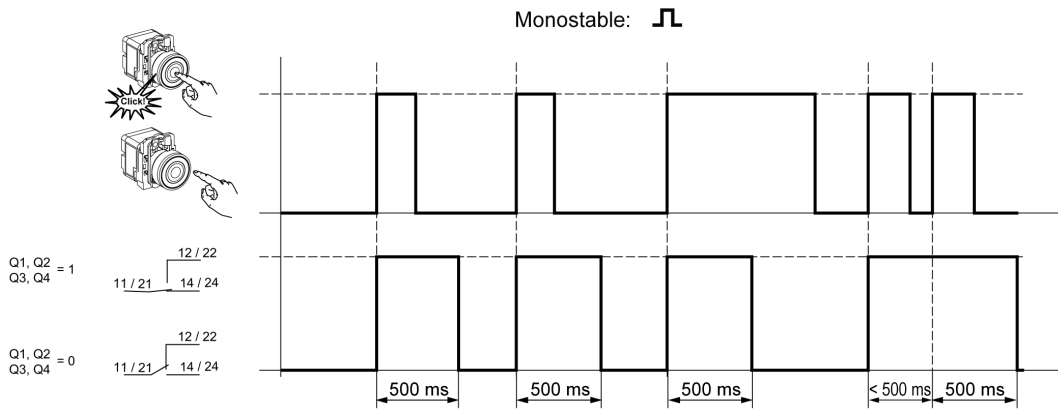

Bistable Output: Only for ZBRRA

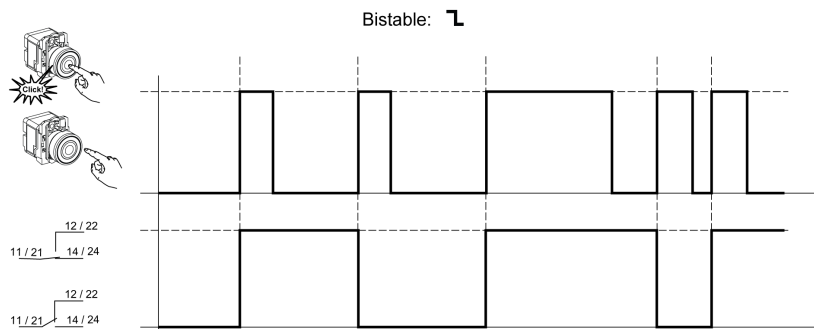

Stop/Start Output Standard Operation: Only for ZBRRA

Description for situations where Stop button does not have priority over Start button:

Stop/Start: ②-①

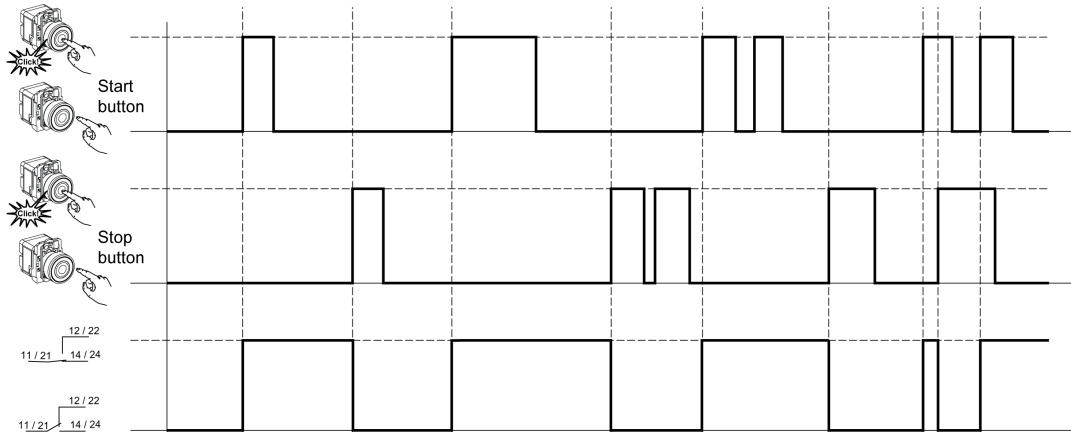

NOTE: This function requires two transmitters.

Stop/Start Output Advanced Operation: Only for ZBRRRA

Description for situations where Stop button has priority over Start button. In this situation, when the Stop button is pushed, the Start button is not immediately operational. You must push the Reset button before the Start button can be pushed.

Electrical Schematics:

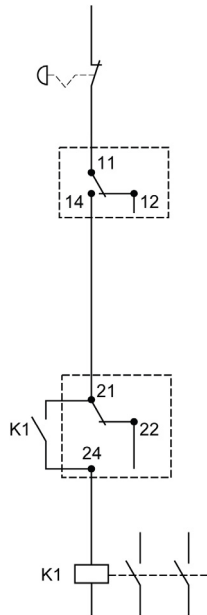

Configuration:

Q1: configured as Stop/Start (refer to Changing Output From Monostable to Stop/Start for XB•RFA02, XB5RMA04, ZBRRRA (see page 49))

Q2: configured as Monostable

Stop button: taught as Stop for Q1 (refer to How to Teach Stop/Start Outputs for XB•RFA02, XB5RMA04, ZBRRRA (see page 55))

Reset button: taught as Start for Q1 (refer to How to Teach Stop/Start Outputs for XB•RFA02, XB5RMA04, ZBRRRA (see page 55))

Start button: taught for Q2

Stop/Start: - with Stop in priority

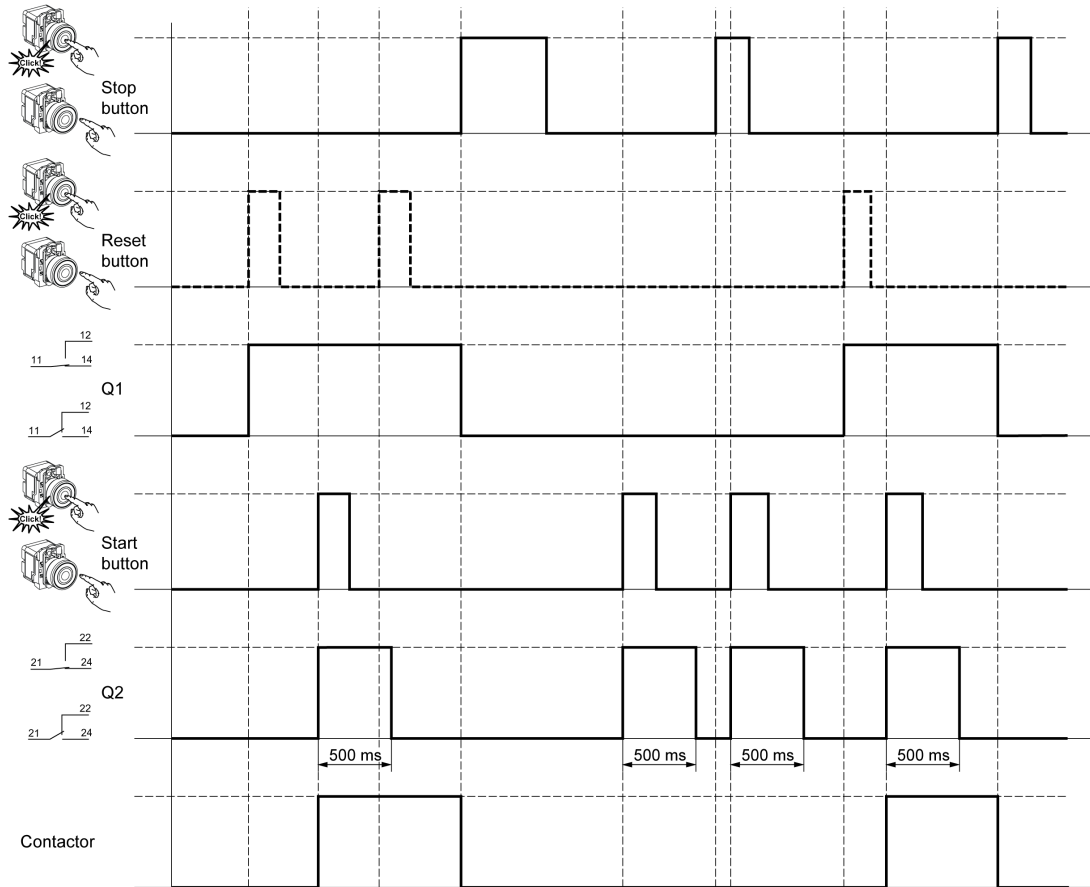

Power outage and restore management





If the duration of a power outage is less than the power supply filtering time (approx. 7 ms), there will be no impact on the receiver, which continues normal operation. Power outages longer than the filtering time cause the product to restart when power is back. At restart the outputs will be in their initial states with LEDs off.

Changing outputs from Monostable to Bistable for XB•RFA02, XB5RMA04, ZBRRA

Procedure

This procedure shows how to change Q1 and Q2 outputs from monostable to bistable.

The icons shown have the following meanings:

LEDs	Meaning
	On
	Flashing
	Monostable
	Bistable

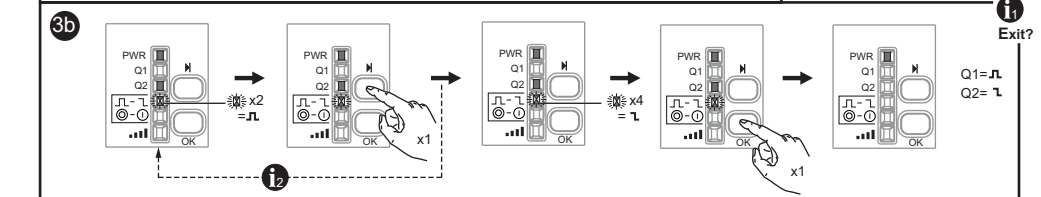
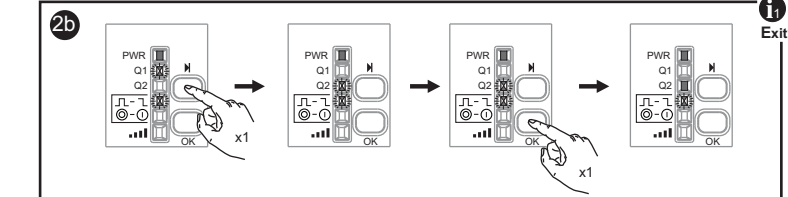
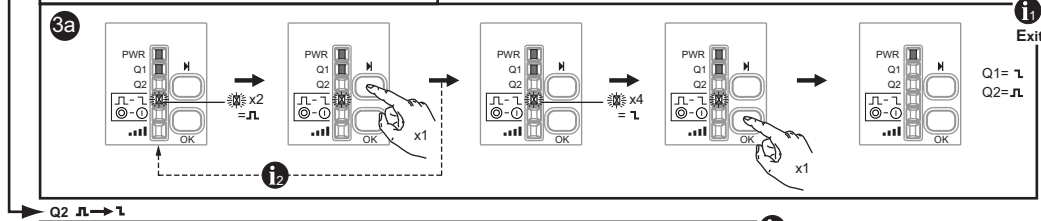
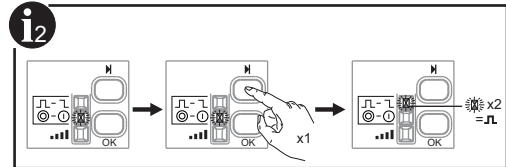
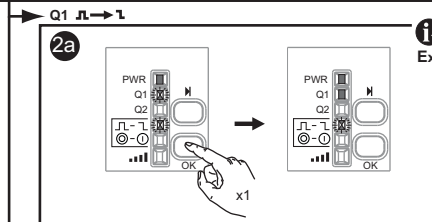
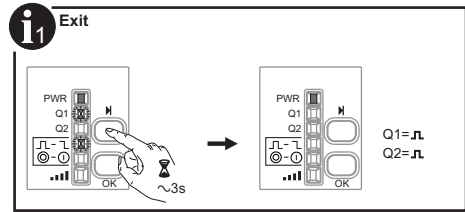
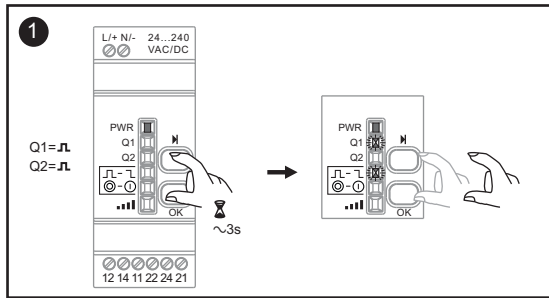





Changing Outputs From Monostable to Stop/Start for XB•RFA02, XB5RMA04, ZBRRA

Procedure

This procedure shows how to change from monostable to Stop/Start for Q1 and Q2

The icons shown have the following meanings:

LEDs	Meaning
	On
	Flashing
	Monostable
	Stop/Start

NOTE: When changing the output from Monostable to Stop/Start, all the registered ID for this output will be automatically canceled from the receiver memory.

For information this also happens for the three following cases:

- From bistable to Stop/Start.
- From Stop/Start to monostable.
- From Stop/Start to bistable.

When changing the output from Monostable to Bistable, or Bistable to Monostable, the registered ID are not cancelled from the receiver memory.

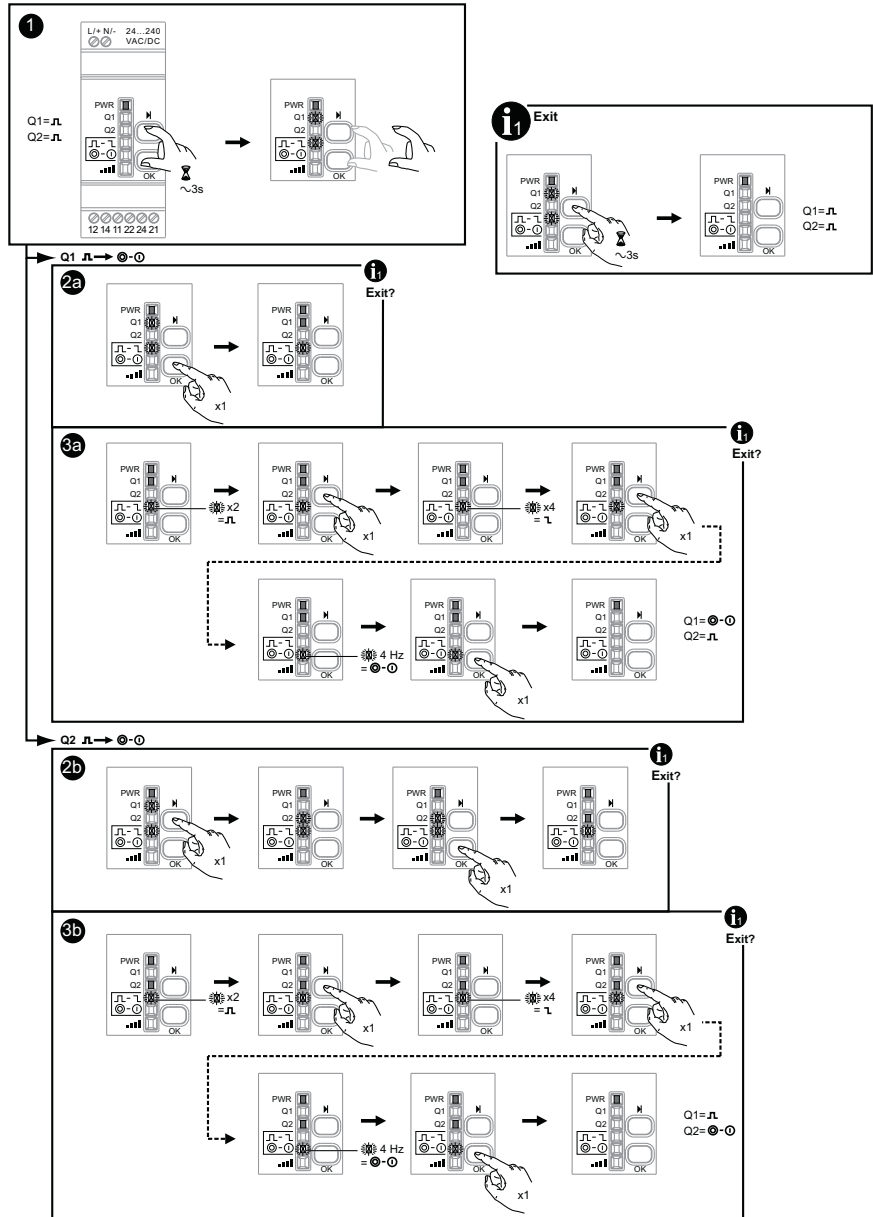



How to Teach/Unteach Monostable or Bistable Outputs for XB•RFA02, XB5RMA04, ZBRRRA, ZBRRC

Procedure

This procedure shows how to Teach/Unteach Q1 and Q2 outputs (ZBRRRA) and Q1, Q2, Q3 and Q4 outputs (ZBRRC) when using monostable or bistable outputs.

The icons shown have the following meanings:

LEDs	Meaning
	Green
	Yellow
	Flashing
	Monostable
	Bistable
	Stop/Start

NOTE: It is possible to store a maximum of 32 ID. For example, 32 ID on Q1 output and 0 ID on Q2 output, or 22 ID on Q1 output and 10 ID on Q2 output, can be stored on ZBRRRA and ZBRRC.

When trying to teach a 33rd ID, all LEDs (except the power LED) flash quickly.

This 33rd ID is not taught.

For ZBRRA, XB•RFA02, XB5RMA04:

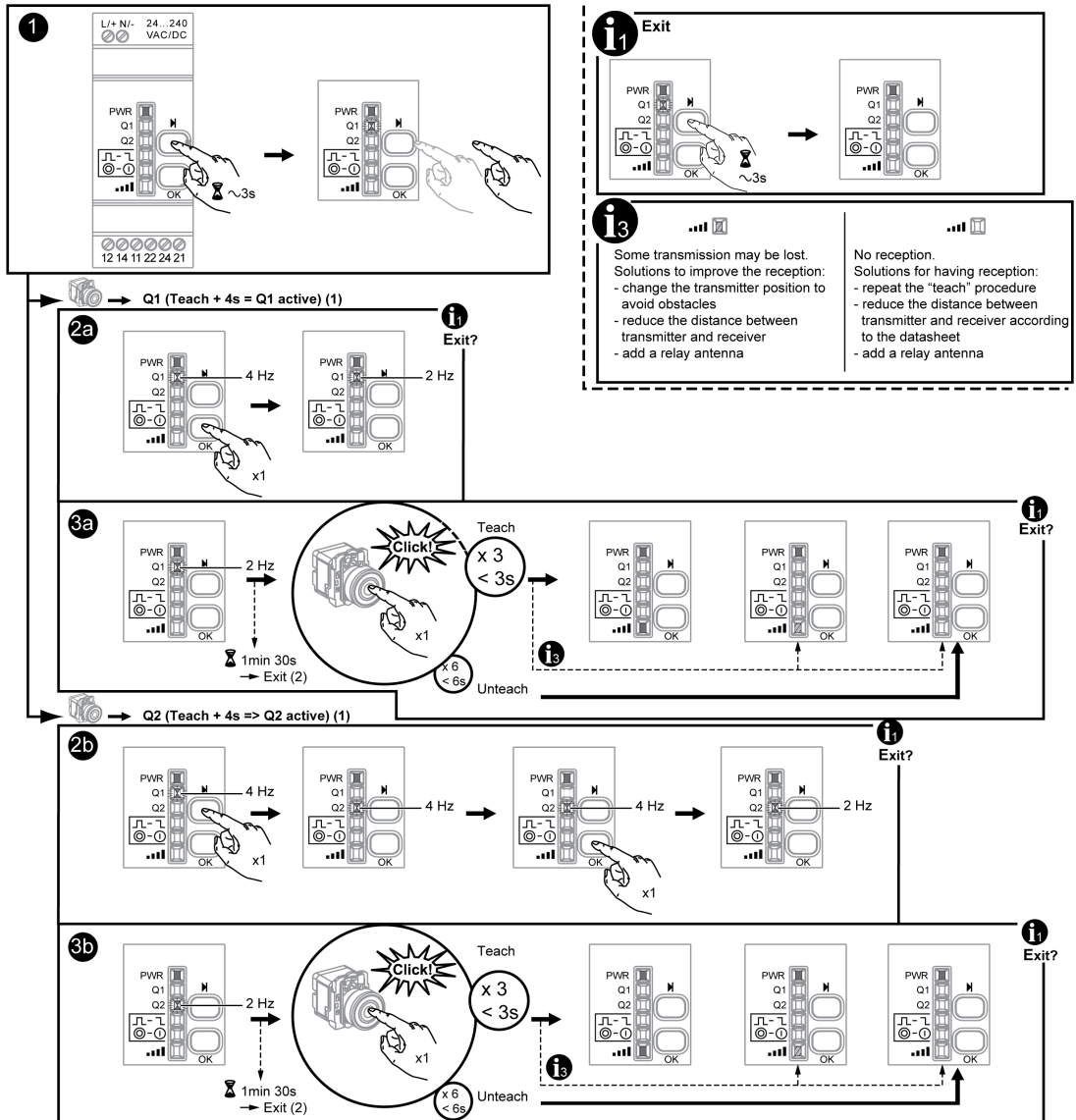

- 1) The Q1 or Q2 outputs will be active only 4s after the teaching procedure.
- 2) The teaching procedure must be performed within 1min 30s.

For ZBRRC:

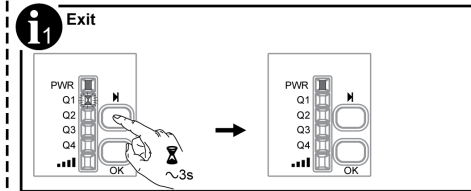
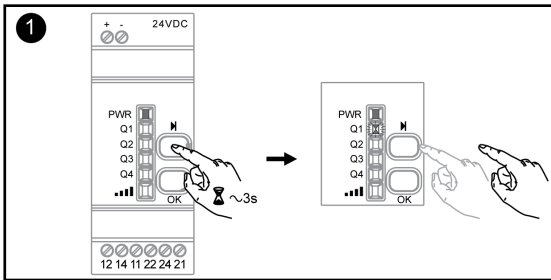

i3

<p>Some transmission may be lost. Solutions to improve the reception:</p> <ul style="list-style-type: none"> - change the transmitter position to avoid obstacles - reduce the distance between transmitter and receiver - add a relay antenna 	<p>No reception. Solutions for having reception:</p> <ul style="list-style-type: none"> - repeat the "teach" procedure - reduce the distance between transmitter and receiver according to the datasheet - add a relay antenna
---	---

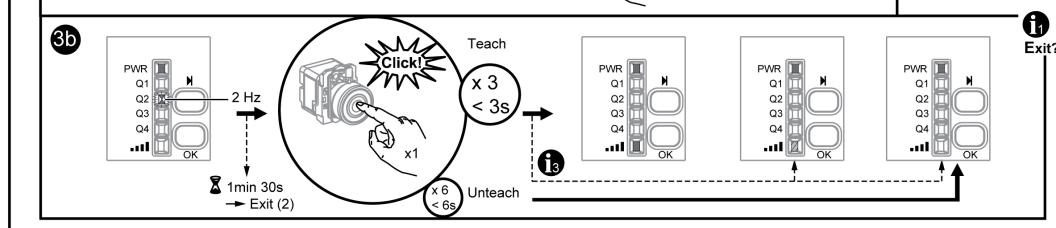
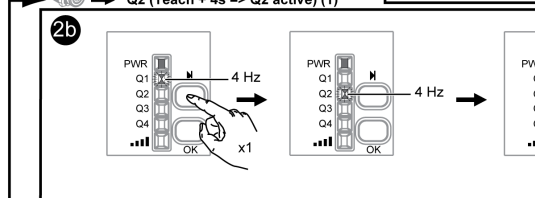
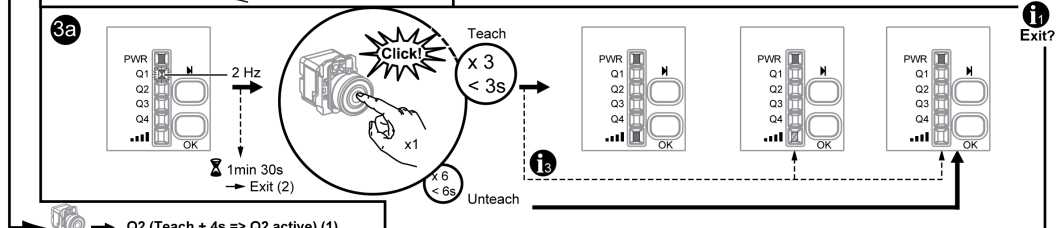
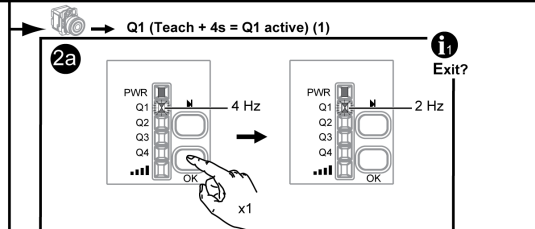

(3)

- 1) The Q1, Q2, Q3 or Q4 outputs will be active only 4s after the teaching procedure.
- 2) The teaching procedure must be performed within 1min 30s.
- 3) The teach procedure on Q3 and Q4 outputs is the same. The Q3 or the Q4 output must be selected and when the Q3 or Q4 LED is flashing at 2 Hz the button can be taught.

How to Teach Stop/Start Outputs for XB•RFA02, XB5RMA04, ZBRRA

Preliminary information

By default, the relay option is monostable. Before proceeding, change the relay option to Stop/Start. Changing Outputs From Monostable to Stop/Start (see page 49) for more information.

Procedure

This procedure shows how to teach Q1 and Q2 outputs when using Stop/Start outputs.

The icons shown have the following meanings:

LEDs	Meaning
	Green
	Yellow
	Flashing
	Monostable
	Bistable
	Stop/Start

NOTE: It is possible to store a maximum of 32 ID. For example, 32 ID on Q1 output and 0 ID on Q2 output or 22 ID on Q1 output and 10 ID on Q2 output, can be stored on ZBRRA.

When trying to teach a 33rd, all LEDs (except the power LED) flash quickly.

This 33rd ID is not taught.

WARNING

UNINTENDED EQUIPMENT OPERATION

Do not leave the receiver without taught Stop button.

Failure to follow these instructions can result in death, serious injury, or equipment damage.

NOTE: For the teach procedure the Stop buttons must be taught before the Start ones. If you start by teaching a Start button (without any Stop button taught) all the LEDs flash. For the unteach procedure all the Start buttons must be untaught before the Stop ones.

How to Teach Q1 for Stop/Start

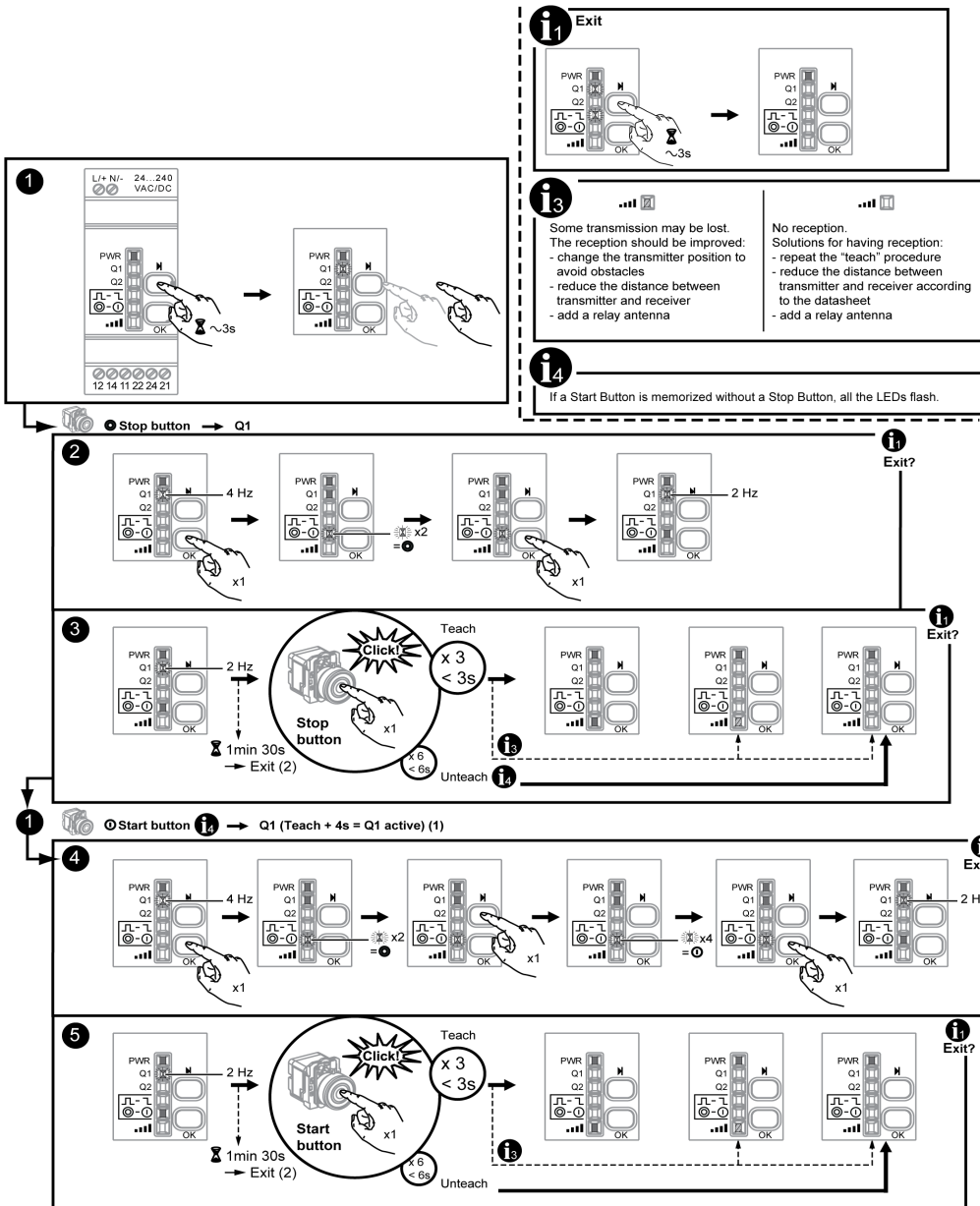

- 1)** The Q1 output will be active only 4s after the teaching procedure.
- 2)** The teaching procedure must be performed within 1min 30s.

How to Teach Q2 for Stop/Start

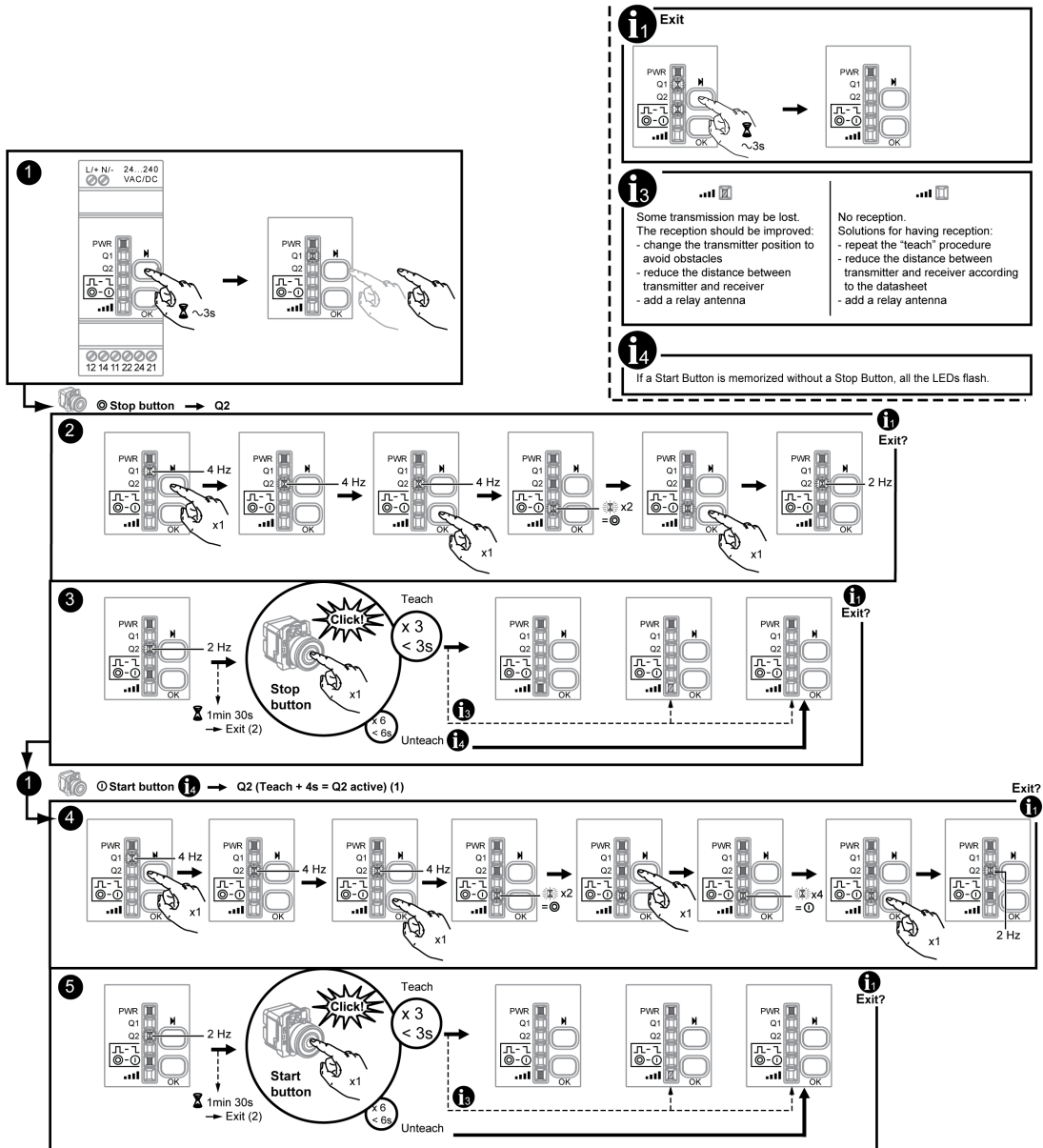

- 1) The Q2 output will be active only 4s after the teaching procedure.
- 2) The teaching procedure must be performed within 1min 30s.

Lock/Unlock for XB•RFA02, XB5RMA04, ZBRRA, ZBRRC

Introduction

Lock enables to block the menus access by non authorized persons. The functioning of the receiver is not affected.

Mechanical Lock/Unlock

The following diagram shows how to perform buttons mechanical lock.

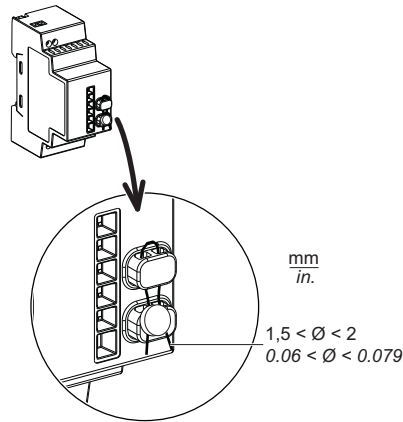

Electronic Lock/Unlock

This procedure shows how to electronically lock/unlock the receiver.

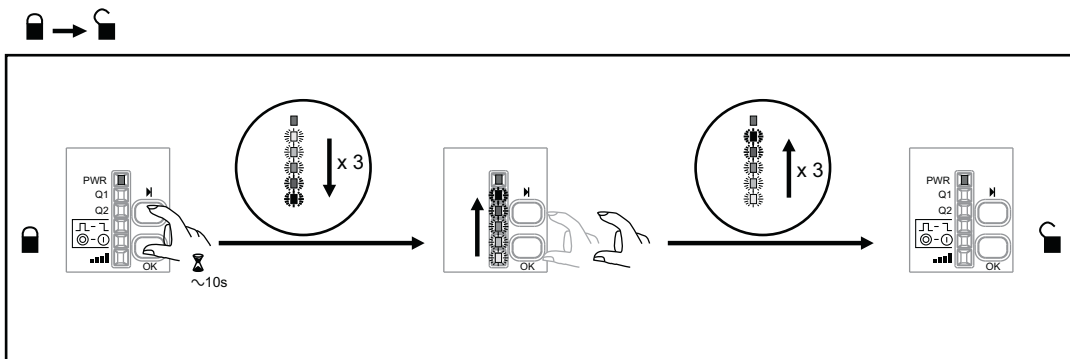
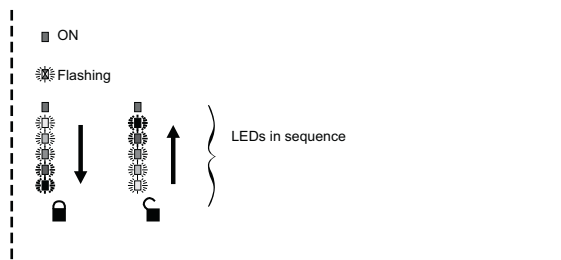
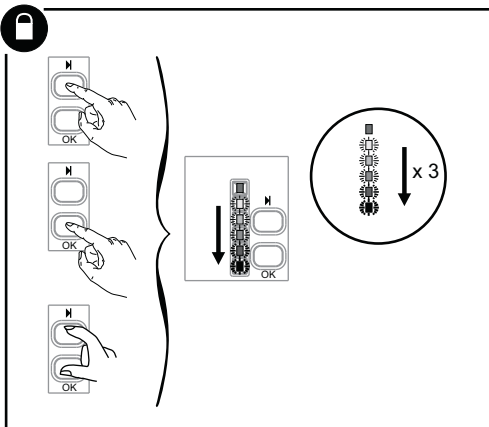
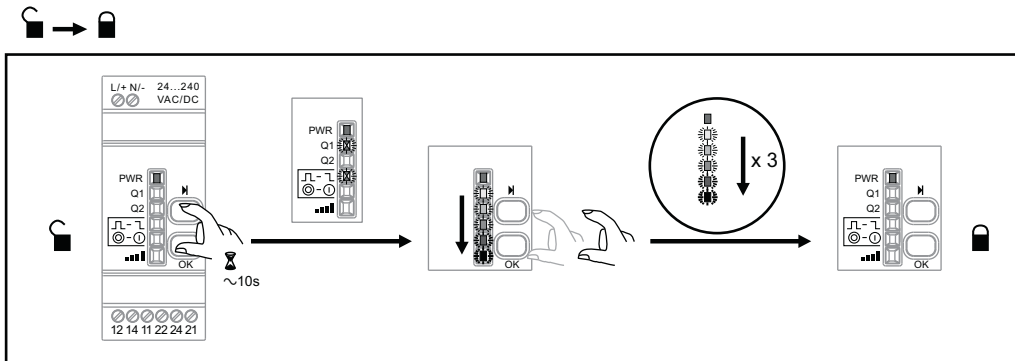

Other Functions for Harmony XB5R



Other Functions Description

Total Reset and ID Reset procedure for XB•RFA02, XB5RMA04, ZBRRRA, ZBRRRC

Total Reset: After a Total Reset the receiver is on factory setting. All outputs are set to monostable function and all the registered ID are canceled.

ID Reset: This function enables to cancel an ID without having the push button (e.g: lost push button). Only the transmitter ID is needed. The ID cancelation does not effect the output function.

NOTE: To reset an ID, the last 3 digits are needed. The first, second and third digits must be entered as binary coded numbers in the receiver during the ID Reset procedure.

For ZBRR:

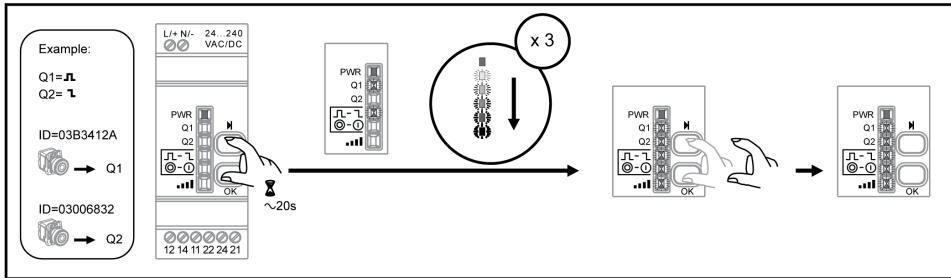

Reset total

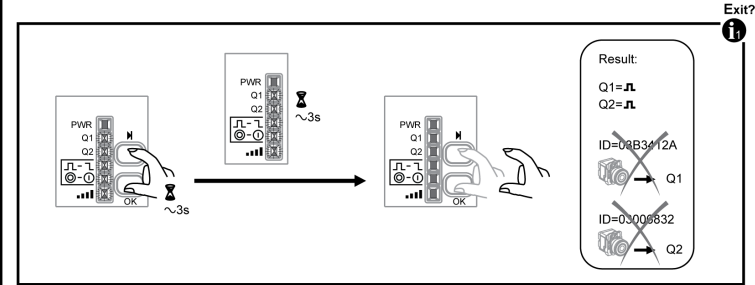

Reset ID

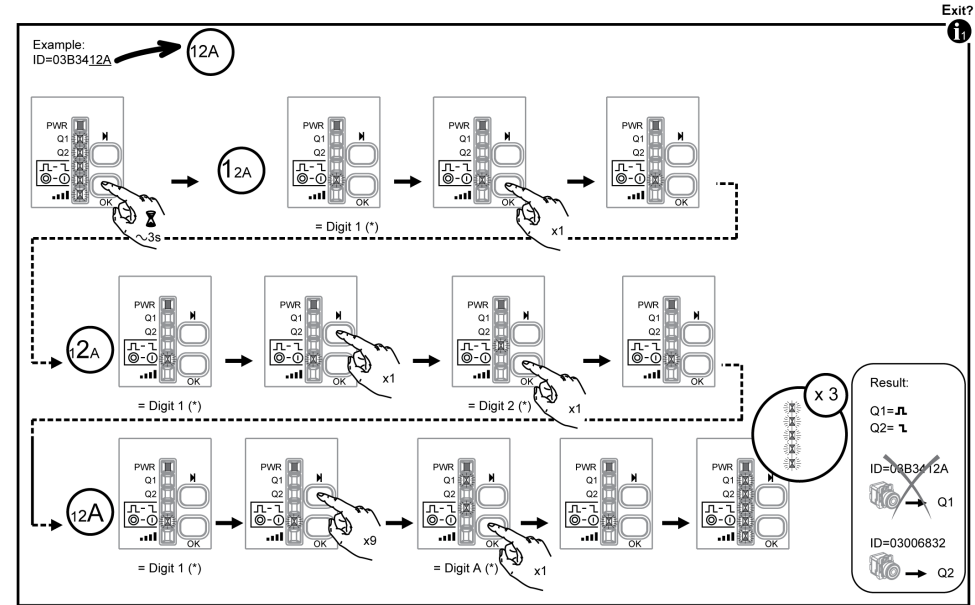

For ZBRRC:

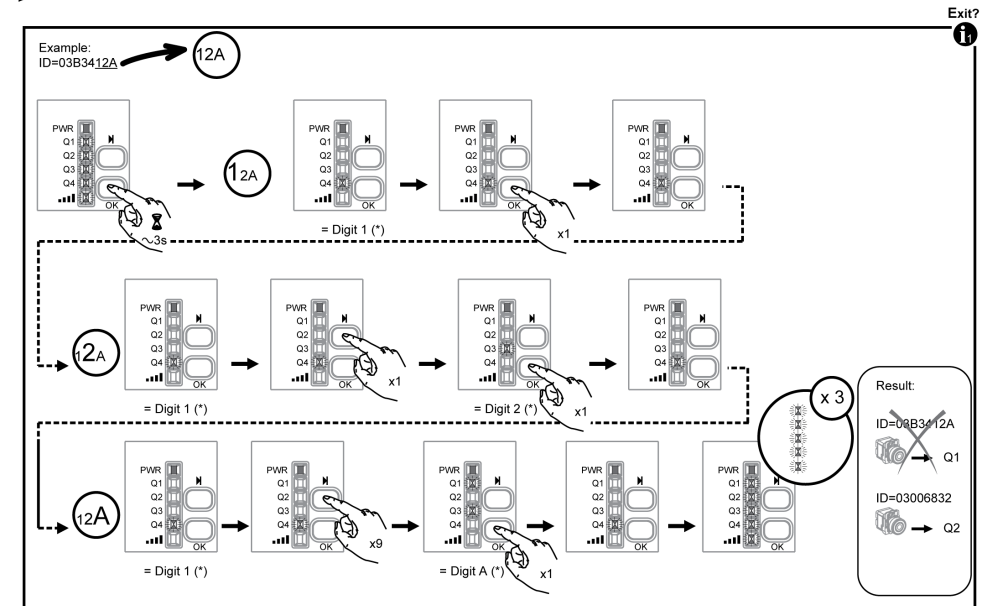
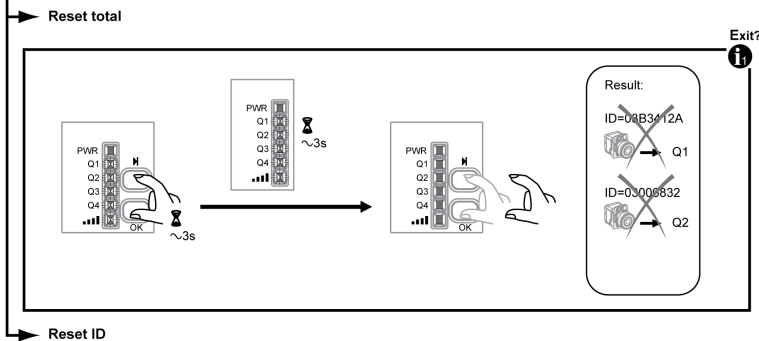
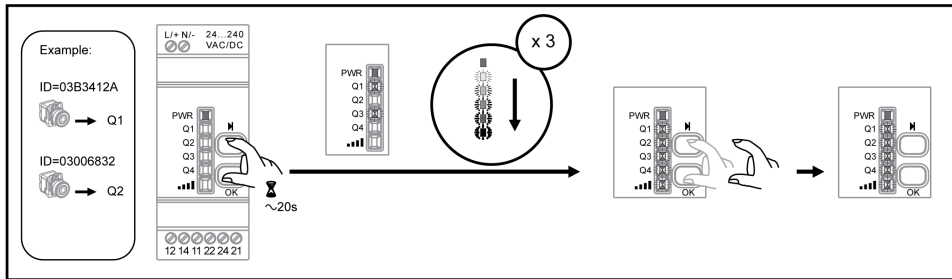

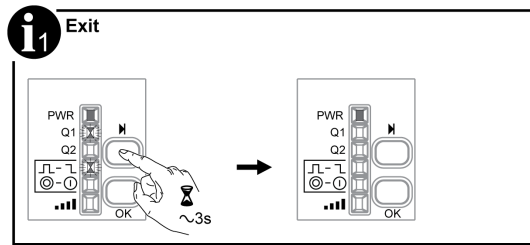

ID Binary Coding

LED		(*) : Digit ID															
ZBRRC	ZBRRA	1	2	3	4	5	6	7	8	9	A	B	C	D	E	F	0
Q1	Q1																
Q2	Q2																
Q3																	
Q4																	