

Features

1 & 2 Pole relay interface modules,
15.8 mm wide.

Ideal interface for PLC and electronic systems

- 48.61 - 1 Pole 16 A (screw terminal)
- 48.81 - 1 Pole 16 A (screwless terminal)
- 48.62 - 2 Pole 10 A (screw terminal)
- 48.82 - 2 Pole 10 A (screwless terminal)

- AC coils or DC sensitive coils
- Instant ejection of relay using plastic retaining clip
- Supply status indication and EMC coil suppression module as standard
- Identification label
- UL Listing (certain relay/socket combinations)
- 35 mm rail (EN 50022) mounting

48.61 / 48.62
Screw terminal

48.81 / 48.82
Screwless terminal



For outline drawing see page 5

Contact specification

Contact configuration		1 CO (SPDT)	2 CO (DPDT)
Rated current/Maximum peak current	A	16*/30	10/20
Rated voltage/Maximum switching voltage	V AC	250/400	250/400
Rated load AC1	VA	4,000	2,500
Rated load AC15 (230 V AC)	VA	750	500
Single phase motor rating (230 V AC)	kW	0.55	0.37
Breaking capacity DC1: 30/110/220V	A	16/0.3/0.12	10/0.3/0.12
Minimum switching load	mW (V/mA)	500 (10/5)	300 (5/5)
Standard contact material		AgCdO	AgNi

Coil specification

Nominal voltage (U _N)	V AC (50/60 Hz)	12 - 24 - 110 - 120 - 230	—
	V DC	12 - 24 - 125	12 - 24 - 125
Rated power AC/sens. DC	VA (50 Hz)/W	1.2/0.5	—/0.5
Operating range	AC	(0.8...1.1)U _N	—
	sens. DC	(0.8...1.5)U _N	(0.8...1.5)U _N
Holding voltage	AC/DC	0.8 U _N / 0.4 U _N	—/0.4 U _N
Must drop-out voltage	AC/DC	0.2 U _N / 0.1 U _N	—/0.1 U _N

Technical data

Mechanical life AC/DC	cycles	10 · 10 ⁶ /20 · 10 ⁶	—/20 · 10 ⁶
Electrical life at rated load AC1	cycles	100 · 10 ³	100 · 10 ³
Operate/release time	ms	7/4 (AC) - 12/12 (DC)	12/12 (DC)
Insulation between coil and contacts (1.2/50 μs)	kV	6 (8 mm)	6 (8 mm)
Dielectric strength between open contacts	V AC	1,000	1,000
Ambient temperature range	°C	-40...+70	-40...+70
Protection category		IP 20	IP 20

Approvals relay (according to type)



48.61/81



- 1 pole, 16 A
- Screw terminal and screwless terminal
- 35 mm rail (EN 50022) mounting

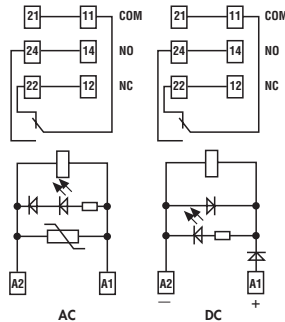

* For currents >10 A, contact terminals must be connected in parallel (21 with 11, 24 with 14, 22 with 12).

48.62/82



- 2 pole, 10 A
- Screw terminal and screwless terminal
- 35 mm rail (EN 50022) mounting

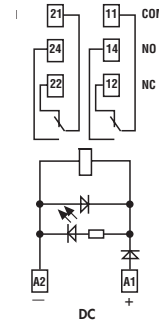

Ordering information

Example: 48 series, 35 mm rail (EN 50022) mount, screw terminal relay interface module, 2 CO (DPDT) 8 A contacts, 24 V sensitive DC coil, green LED + diode, 99.02 coil indication.

	A	B	C	D
4 8 . 5 2 . 7 . 0 2 4 . 0 0 5 0				
<p>Series _____</p> <p>Type _____</p> <p>Screw terminal</p> <p>3 = 35 mm rail mount (EN 50022)</p> <p>5 = 35 mm rail mount (EN 50022)</p> <p>6 = 35 mm rail mount (EN 50022)</p> <p>Screwless terminal</p> <p>7 = 35 mm rail mount (EN50022)</p> <p>8 = 35 mm rail mount (EN50022)</p> <p>No. of poles _____</p> <p>1 = 1 pole for 48.31, 10 A 48.61, 48.81, 16 A</p> <p>2 = 2 pole for 48.52, 48.72, 8 A 48.62, 48.82, 10 A (48.62, 48.82 DC only)</p> <p>Coil version _____</p> <p>7 = Sensitive DC</p> <p>8 = AC (50/60 Hz)</p> <p>Coil voltage _____</p> <p>See coil specifications</p>	<p>A: Contact material</p> <p>0 = Standard</p> <p>B: Contact circuit</p> <p>0 = CO (nPDT)</p>	<p>C: Options</p> <p>5 = Standard for DC: green LED + diode (polarity +A1)</p> <p>6 = Standard for AC: green LED + Varistor</p>	<p>D: Special versions</p> <p>0 = Standard</p>	

Technical data

Insulation		48.31/61/62	48.52	48.31/61/62
Insulation according to EN 61810-1	insulation rated voltage	V	250	250
	rated impulse withstand voltage	kV	4	4
	pollution degree		3	2
	overvoltage category		III	III
Insulation between coil and contacts (1.2/50 µs)		kV	6 (8 mm)	
Dielectric strength between open contacts		V AC	1,000	
Dielectric strength between adjacent contacts		V AC	2,000 (48.52); 2,500 (48.62)	
Conducted disturbance immunity				
Burst (5...50)ns, 5 kHz, on A1 - A2			EN 61000-4-4	level 4 (4 kV)
Surge (1.2/50 µs) on A1 - A2 (differential mode)			EN 61000-4-5	level 3 (2 kV)
Other data				
Bounce time: NO/NC		ms	2/5	
Vibration resistance (5...55)Hz: NO/NC		g	10/4 (for 1 pole)	15/3 (for 2 pole)
Power lost to the environment	without contact current	W	0.7	
	with rated current	W	1.2 (48.31)	1.3 (48.52/72) 1.2 (48.61/62/81/82)
Wire strip length		mm	8	
Screw torque		Nm	0.5	
Max. wire size			Screw terminal	
			solid cable	stranded cable
	mm ²	1x6 / 2x2.5	1x4 / 2x2.5	2x(0.2...1.5) 2x(0.2...1.5)
	AWG	1x10 / 2x14	1x12 / 2x14	2x(24...18) 2x(24...18)
		Screwless terminal		
		solid cable	stranded cable	
mm ²	1x6 / 2x2.5	1x4 / 2x2.5	2x(0.2...1.5)	2x(0.2...1.5)
AWG	1x10 / 2x14	1x12 / 2x14	2x(24...18)	2x(24...18)

Contact specification

F 48 - Electrical life (AC) v contact current
Types 48.31/61/81

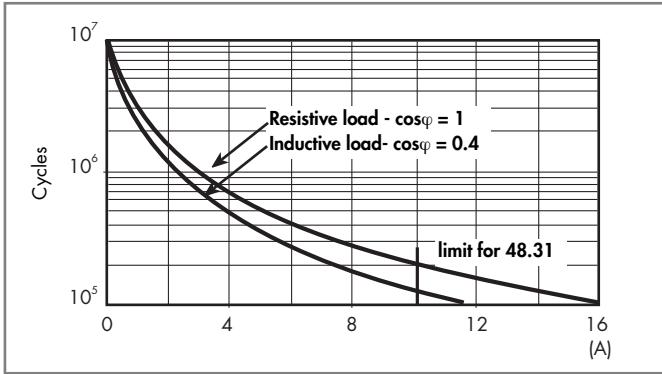

F 48 - Electrical life (AC) v contact current
Types 48.62/82

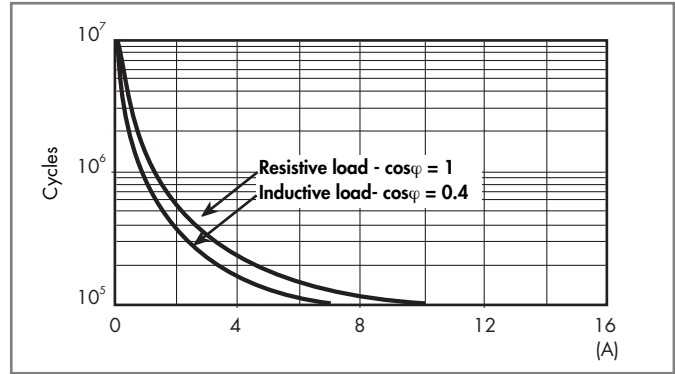

F 48 - Electrical life (AC) v contact current
Types 48.52/72

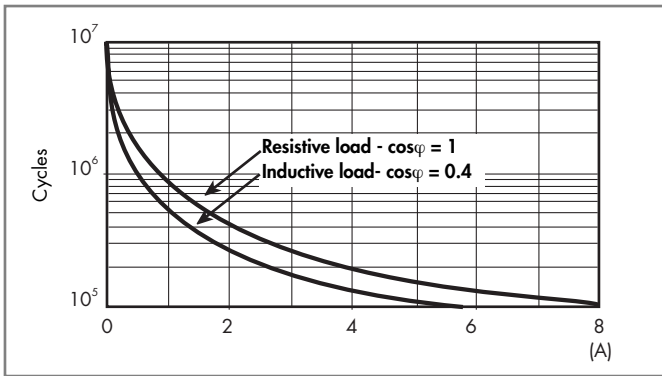

H 48 - Maximum DC1 breaking capacity
Types 48.31/52/61/72/81

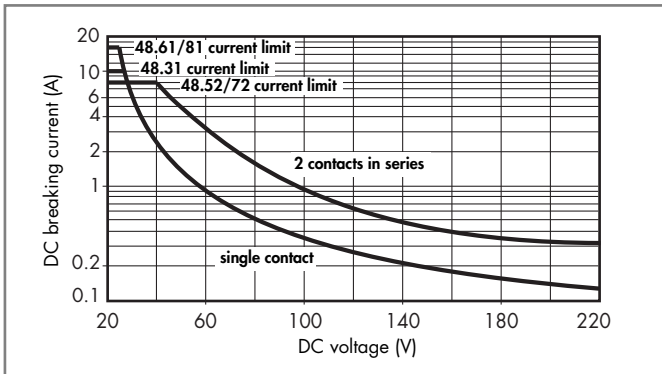

H 48 - Maximum DC1 breaking capacity
Types 48.62/82

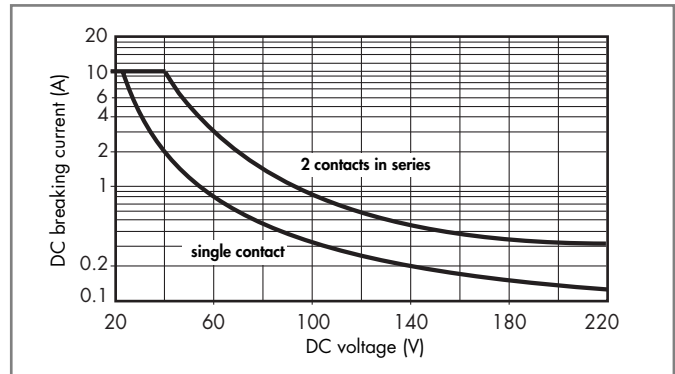

- When switching a resistive load (DC1) having voltage and current values under the curve, an electrical life of $\geq 100 \cdot 10^3$ can be expected.
- In the case of DC13 loads, the connection of a diode in parallel with the load will permit a similar electrical life as for a DC1 load.
Note: the release time for the load will be increased.

- When switching a resistive load (DC1) having voltage and current values under the curve, an electrical life of $\geq 100 \cdot 10^3$ can be expected.
- In the case of DC13 loads, the connection of a diode in parallel with the load will permit a similar electrical life as for a DC1 load.
Note: the release time for the load will be increased.

Coil specifications

DC coil data (0.5 W sensitive)

Nominal voltage U_N V	Coil code	Operating range		Rated coil consumption I at U_N mA
		U_{min}^* V	U_{max}^{**} V	
12	7.012	8.8	21	41
24	7.024	17.5	42	22.2
125	7.125	91	219	4

* $U_{min} = 0.8 U_N$ for 48.61, 48.62, 48.81 and 48.82

** $U_{max} = 1.5 U_N$ for 48.61, 48.62, 48.81 and 48.82

AC coil data

Nominal voltage U_N V	Coil code	Operating range		Rated coil consumption I at U_N (50Hz) mA
		U_{min} V	U_{max} V	
12	8.012	9.6	13.2	90.5
24	8.024	19.2	26.4	46
110	8.110	88	121	10.1
120	8.120	96	132	11.8
230	8.230	184	253	7.0

R 48 - DC coil operating range v ambient temperature

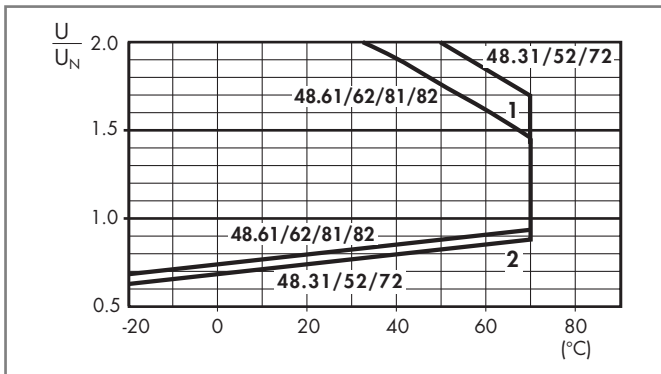

1 - Max. permitted coil voltage.

2 - Min. pick-up voltage with coil at ambient temperature.

R 48 - DC coil operating range v ambient temperature

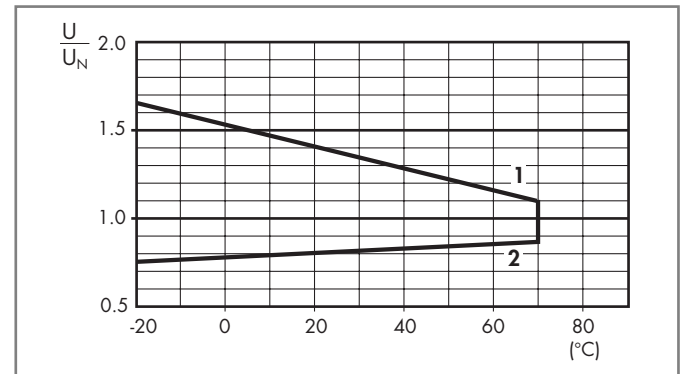

1 - Max. permitted coil voltage.

2 - Min. pick-up voltage with coil at ambient temperature.

Combinations

Code	Type of socket	Type of relay	Module	Retaining clip
48.31	95.03	40.31	99.02	095.01
48.52	95.05	40.52	99.02	095.01
48.61	95.05	40.61	99.02	095.01
48.62	95.05	44.62	99.02	095.01
48.72	95.55	40.52	99.02	095.91.3
48.81	95.55	40.61	99.02	095.91.3
48.82	95.55	44.62	99.02	095.91.3

Outline drawing

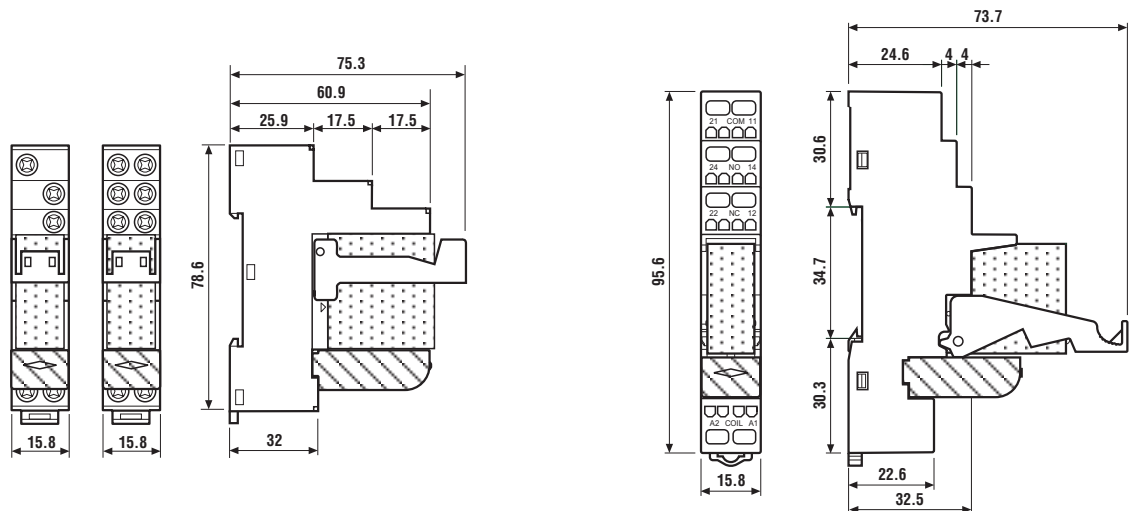

48.31 / 48.52 / 48.61 / 48.62
Screw terminal



48.72 / 48.81 / 48.82
Screwless terminal



Accessories



095.18

8-way jumper link for screw terminal version	095.18 (blue)	095.18.0 (black)
Rated values	10 A - 250 V	

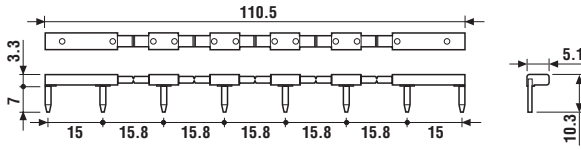

060.72

Sheet of marker tags , plastic, 72 tags, 6x12 mm	060.72
---	--------

Packaging codes

How to code and identify retaining clip and packaging options for sockets.

Example:

