

Common features

- Space saving 6.2 mm wide
- Connections for 16-way jumper link
- Integral coil indication and protection circuit
- Secure retention and easy ejection by plastic clip
- Dual screw head (blade+cross) terminals
- 35mm rail mounting (EN 60715)

MasterBASIC

- For general use in any type of system
- **EMR: 6 to 24 V AC/DC and 230 V AC supply**
- **SSR: 6 to 24 V DC and 230 V AC supply**

MasterPLUS

- Accepts the output fuse module, for the easy and space efficient protection of output circuits
- **EMR: 6 to 125 V AC/DC, 125 and 220 V DC, 230 V AC supply**
- **SSR: 24 - 125 V AC/DC, 6 to 220 V DC and 230 V AC supply**
- **Special 125 and 230 V AC leakage current suppression types (39.31.3 EMR and 39.30.3 SSR)**

MasterINPUT

- Jumper link option for the quick and easy distribution of supply voltage to proximity switches and similar input devices
- Fuse option for Outputs
- **EMR: 6 to 24 V and 125 V AC/DC, 230 V AC supply**
- **SSR: 6 - 12 V DC, 24 - 125 V AC/DC, 230 V AC supply**

MasterOUTPUT

- Jumper link option for the quick and easy distribution of supply voltage to output side and its connection to electromagnetic valves and similar output devices
- **EMR: 6 to 24 V and 125 V AC/DC, 230 V AC supply**
- **SSR: 6 to 24 V DC, 125 V AC/DC, 230 V AC supply**

MasterTIMER

- Timer adjustment via top mounted rotary knob accessible after assembly
- Control signal terminal
- DIP-switch for selection of 4 time scales and 8 functions
- Output with fuse module option
- **EMR and SSR: 12 to 24 V AC/DC supply**

EMR Electromechanical Relays

- **1 CO 6 A 250 V AC**
- High switching capability

SSR Solid State Relays

- 1 solid state output (options **0.1 A 48 V DC, 2 A 24 V DC, 2 A 240 V AC**)
- Silent, high speed switching, long electrical life

39.11



Page 4

39.10



Page 5

39.31 - 39.31.3



Page 6

39.30 - 39.30.3



Page 7

39.41



Page 8

39.40



Page 9

39.21



Page 10

39.20



Page 11

39.81



Page 12

39.80



Page 13

MasterBASIC
39.11 - 39.10

- For general interface use in any type of system and application.
- Can be used for input interface applications between auxiliary contacts, sensors etc. and controllers, PLCs' or motors. Or for output interface between PLC's controllers and relays, solenoids etc.

MasterPLUS
39.31 - 39.30 - 39.31.3 - 39.30.3

This special version provides extra protection for the output circuit thanks to the replaceable fuse module.

- For general interface use in any type of system and application.
- Can be used for input interface applications between auxiliary contacts, sensors etc. and controllers, PLCs' or motors. Or for output interface between PLC's controllers and relays, solenoids etc.

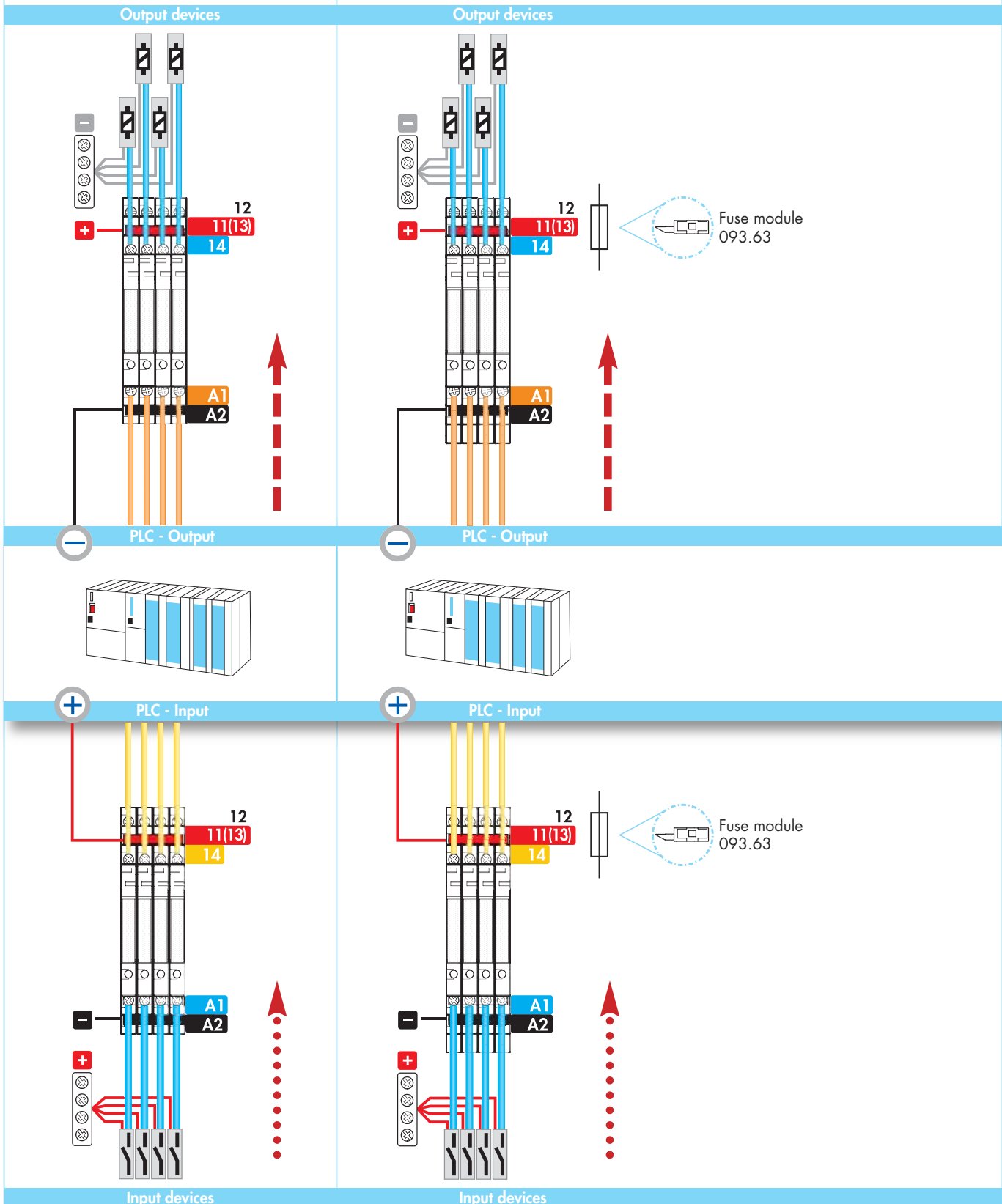

**MasterINPUT
39.41 - 39.40**

- These models allow the full termination of input device to the interface without the need for additional terminals - saving component cost, time and panel space.
- Quick and easy distribution of supply voltage through the jumper link on the Bus-Bar (BB) connection.
- Ideal for interface applications between the auxiliary contacts, sensors, limit switches and Controllers or PLC's.

**MasterOUTPUT
39.21 - 39.20**

- These models allow the full termination of output device to the interface without the need for additional terminals - saving component cost, time and panel space.
- Quick and easy distribution of supply voltage through the jumper link on the Bus-Bar (BB) connection.
- Ideal for interface applications between the PLC's or Controllers and output devices such as electromagnetic valves or motors etc..

**MasterTIMER
39.81 - 39.80**

Slim and Multifunction Timed Interface modules.

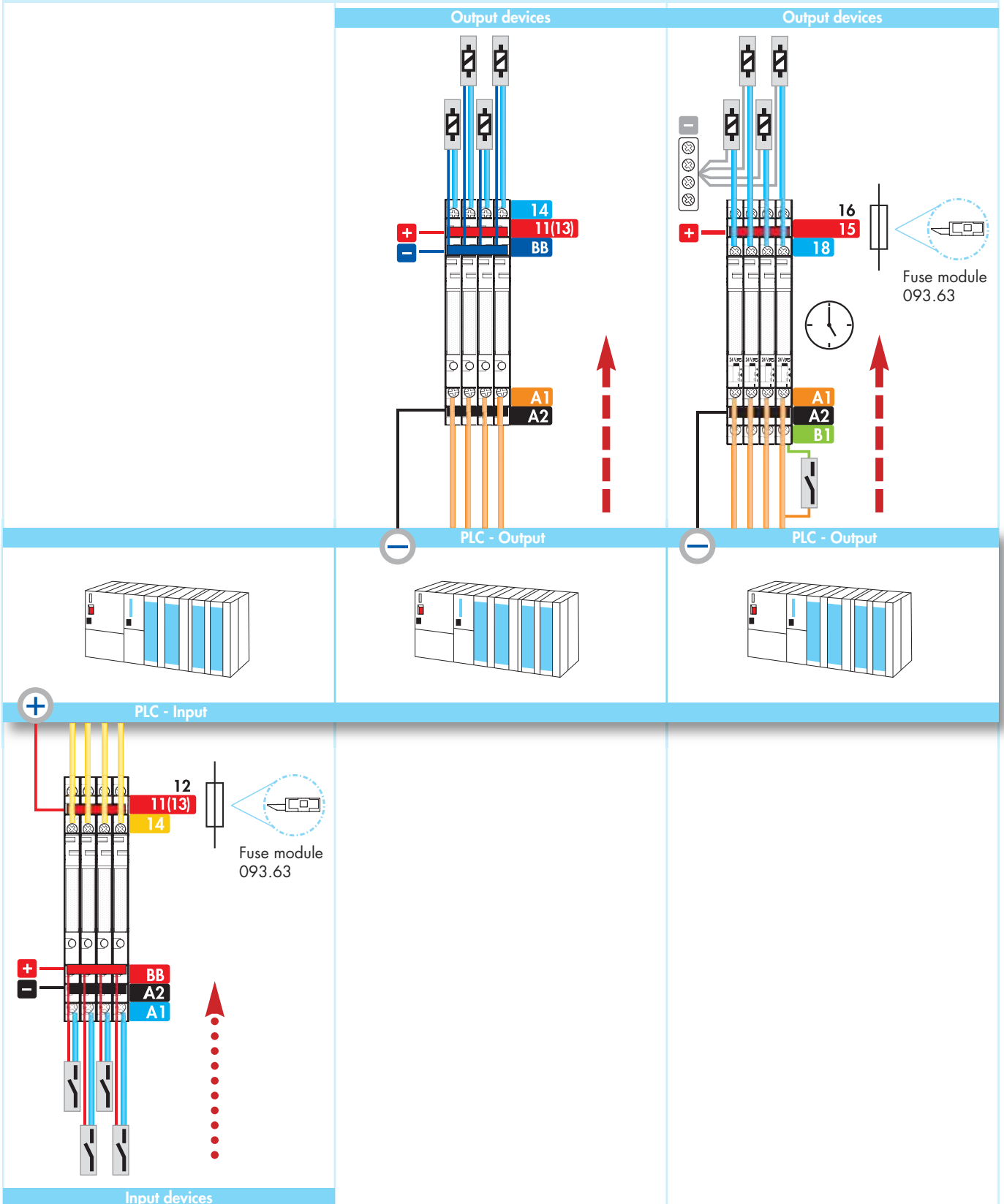

MasterBASIC - EMR

Features

1 Pole interface module, 6.2 mm wide, ideal for PLC electronic systems

- Common connection possible with optional jumper links (terminals A1, A2 and 11)

39.11
Screw terminal



NEW 39.11



- 6 A electromechanical relay
- 6 to 24 V AC/DC and 230 V AC supply
- 35 mm rail (EN 60715) mounting

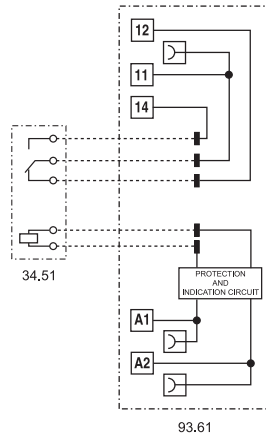

For outline drawing see page 20

Contact specification		
Contact configuration		1 CO (SPDT)
Rated current/Maximum peak current	A	6 / 10
Rated voltage/Maximum switching voltage	V AC	250 / 400
Rated load AC1	VA	1,500
Rated load AC15 (230 V AC)	VA	300
Single phase motor rating (230 V AC)	kW	0.185
Breaking capacity DC1: 30/110/220 V	A	6 / 0.2 / 0.12
Minimum switching load	mW (V/mA)	500 (12 / 10)
Standard contact material		AgNi
Supply specification		
Nominal voltage (U_N)	V DC/AC	6 - 12 - 24
	V AC (50/60 Hz)	220...240
Rated power	VA (50 Hz)/W	See coil specifications page 16
Operating range		$(0.8...1.1)U_N$
Holding voltage		$0.6 U_N$
Must drop-out voltage		$0.1 U_N$
Technical data		
Mechanical life AC/DC	cycles	$10 \cdot 10^6$
Electrical life at rated load AC1	cycles	$60 \cdot 10^3$
Operate/release time	ms	5/6
Insulation between coil and contacts (1.2/50 μ s)	kV	6 (8 mm)
Dielectric strength between open contacts	V AC	1,000
Ambient temperature range	$^{\circ}$ C	-40...+70
Protection category		IP 20
Approvals relay (according to type)		CE

MasterBASIC - SSR

Features

1 Pole interface module, 6.2 mm wide, ideal for PLC and electronic systems

- Common connection possible with optional jumper links (terminals A1, A2 and 13+)

39.10
Screw terminal



NEW 39.10



- 0.1 or 2 A solid state relay
- 6 to 24 V DC and 230 V AC supply
- 35 mm rail (EN 60715) mounting

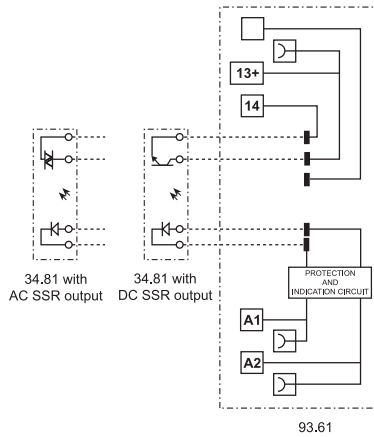

For outline drawing see page 20

Output specification (SSR)	39.10.x.xxx.9024	39.10.x.xxx.7048	39.10.x.xxx.8240
Contact configuration	1 NO (SPST-NO)		
Rated current/Maximum peak current (10 ms) A	2/20 DC	0.1/0.5 DC	2/40 AC
Rated voltage/Maximum blocking voltage V	24/33 DC	48/60 DC	240/275 AC
Switching voltage range V	(1.5...24) DC	(1.5...48) DC	(12...240) AC
Minimum switching current mA	1	0.05	22
Max. "OFF-state" leakage current mA	0.001	0.001	1.5
Max. "ON-state" voltage drop V	0.12	1	1.6
Supply specification			
Nominal voltage (U _N)	V AC (50/60 Hz)	220...240	
	V DC	6 - 12 - 24	
Rated power VA (50 Hz) / W	See input specifications page 17		
Operating range	(0.8...1.1) U _N		
Must drop-out voltage	0.1 U _N		
Technical data			
Operate/release time ms	0.2/0.6	0.04/0.11	12/12
Dielectric strength between input/output V AC	2,500		
Ambient temperature range °C	-20...+55		
Protection category	IP20		
Approvals relay (according to type)	CE		

MasterPLUS - EMR

Features

1 Pole interface modules, 6.2 mm wide, ideal for PLC and electronic systems

- Accepts output fuse module **093.63** (for 5 x 20 mm fuses) for quick and easy load protection, see page 22
- Common connection possible with optional jumper links (terminals A1, A2 and 11)

39.31 / 39.31.3
Screw terminal



NEW 39.31



- 6 A electromechanical relay
- 6 to 125 V AC/DC, 125 and 220 V DC, 230 V AC supply
- 35 mm rail (EN 60715) mounting

NEW 39.31.3



- 6 A electromechanical relay
- Leakage current suppression version, 125 and 230 V AC supply

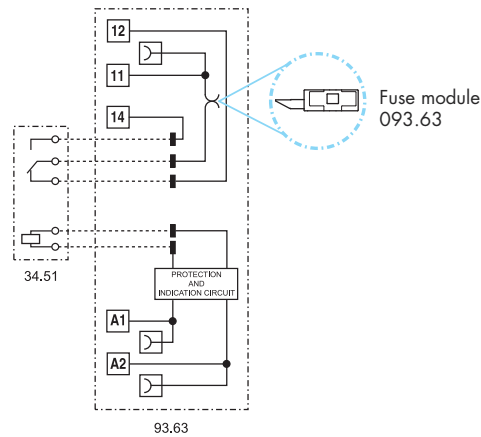

For outline drawing see page 20

Contact specification			
Contact configuration		1 CO (SPDT)	1 CO (SPDT)
Rated current/Maximum peak current	A	6 / 10	6 / 10
Rated voltage/Maximum switching voltage	V AC	250 / 400	250 / 400
Rated load AC1	VA	1,500	1,500
Rated load AC15 (230 V AC)	VA	300	300
Single phase motor rating (230 V AC)	kW	0.185	0.185
Breaking capacity DC1: 30/110/220 V	A	6 / 0.2 / 0.12	6 / 0.2 / 0.12
Minimum switching load	mW (V/mA)	500 (12 / 10)	500 (12 / 10)
Standard contact material		AgNi	AgNi
Supply specification			
Nominal voltage (U_N)	V DC/AC	6 - 12 - 24 - 60 - 110...125	—
	V AC (50/60 Hz)	220...240	110...125 - 220...240
	V DC	110...125 - 220	—
Rated power	VA (50 Hz)/W	See coil specifications page 16	See coil specifications page 16
Operating range		$(0.8...1.1) U_N$	$(0.8...1.1) U_N$
Holding voltage		$0.6 U_N$	$0.6 U_N$
Must drop-out voltage		$0.1 U_N$	$0.3 U_N$
Technical data			
Mechanical life AC/DC	cycles	$10 \cdot 10^6$	$10 \cdot 10^6$
Electrical life at rated load AC1	cycles	$60 \cdot 10^3$	$60 \cdot 10^3$
Operate/release time	ms	5 / 6	5 / 6
Insulation between coil and contacts (1.2/50 μ s)	kV	6 (8 mm)	6 (8 mm)
Dielectric strength between open contacts	V AC	1,000	1,000
Ambient temperature range	$^{\circ}$ C	-40...+70 (+55 for 220 V DC)	-40...+70
Protection category		IP20	IP20
Approvals relay (according to type)		CE	

MasterPLUS - SSR

Features

1 Pole interface modules, 6.2 mm wide, ideal for PLC and electronic systems

- Accepts output fuse module **093.63** (for 5 x 20 mm fuses) for quick and easy load protection, see page 22
- Common connection possible with optional jumper links (terminals A1, A2 and 13+)

39.30 / 39.30.3
Screw terminal



NEW 39.30



- 0.1 or 2 A solid state relay
- 24 - 125 V AC/DC, 6 to 220 V DC and 230 V AC supply
- 35 mm rail (EN 60715) mounting

NEW 39.30.3



- 0.1 or 2 A solid state relay
- Leakage current suppression version, 125 and 230 V AC supply

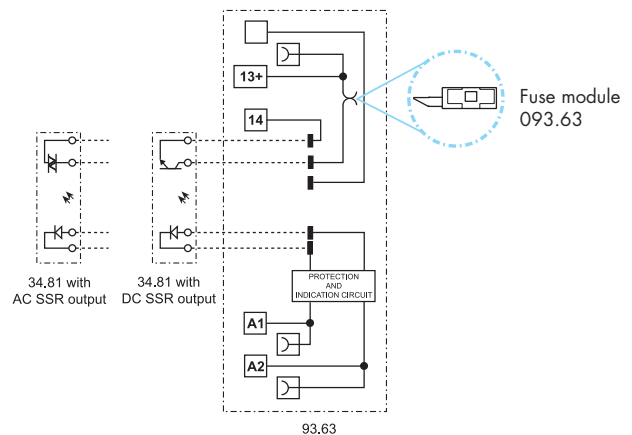

For outline drawing see page 20

Output specification (SSR)	39.30.x.xxx.9024	39.30.x.xxx.7048	39.30.x.xxx.8240	39.30.3.xxx.9024	39.30.3.xxx.7048	39.30.3.xxx.8240
Contact configuration	1 NO (SPST-NO)			1 NO (SPST-NO)		
Rated current/Maximum peak current (10 ms) A	2/20 DC	0.1/0.5 DC	2/40 AC	2/20 DC	0.1/0.5 DC	2/40 AC
Rated voltage/Maximum blocking voltage V	24/33 DC	48/60 DC	240/275 AC	24/33 DC	48/60 DC	240/275 AC
Switching voltage range V	(1.5...24) DC	(1.5...48)DC	(12...240) AC	(1.5...24) DC	(1.5...48)DC	(12...240) AC
Minimum switching current mA	1	0.05	22	1	0.05	22
Max. "OFF-state" leakage current mA	0.001	0.001	1.5	0.001	0.001	1.5
Max. "ON-state" voltage drop V	0.12	1	1.6	0.12	1	1.6
Supply specification						
Nominal voltage (U _N)	V DC/AC	24 - 110...125			—	
	V AC (50/60 Hz)	220...240			110...125 - 220...240	
	V DC	6 - 12 - 24 - 60 - 110...125 - 220			—	
Rated power VA (50 Hz) / W	See input specifications page 17			See input specifications page 17		
Operating range	(0.8...1.1) U _N			(0.8...1.1) U _N		
Must drop-out voltage	0.1 U _N			0.3 U _N		
Technical data						
Operate/release time ms	0.2/0.6	0.04/0.11	12/12	0.2/0.6	0.04/0.11	12/12
Dielectric strength between input/output V AC	2,500			2,500		
Ambient temperature range °C	-20...+55			-20...+55		
Protection category	IP20			IP20		
Approvals relay (according to type)	CE					

MasterINPUT - EMR

Features

1 Pole interface module, 6.2 mm wide, ideal for PLC and electronic systems

- Jumper link option for the quick and easy distribution of supply voltage to proximity switches and similar input devices (Bus-bar connection BB)
- Accepts output fuse module **093.63** (for 5 x 20 mm fuses) for quick and easy load protection, see page 22
- Gold plated output contact as standard, for better compatibility with low energy PLC inputs

39.41
Screw terminal



NEW 39.41



- 6 A electromechanical relay
- 6 - 12 - 24 - 125 V AC/DC and 230 V AC supply
- 35 mm rail (EN 60715) mounting

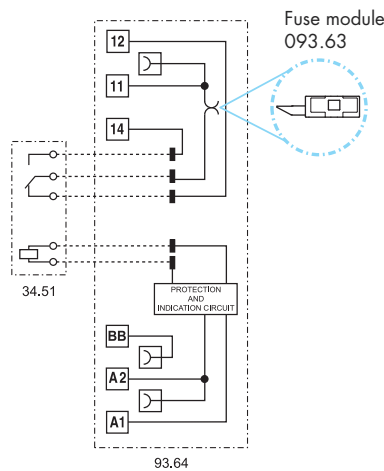

For outline drawing see page 20

Contact specification		
Contact configuration		1 CO (SPDT)
Rated current/Maximum peak current	A	6 / 10
Rated voltage/Maximum switching voltage	V AC	250 / 400
Rated load AC1	VA	1,500
Rated load AC15 (230 V AC)	VA	300
Single phase motor rating (230 V AC)	kW	0.185
Breaking capacity DC1: 30/110/220 V	A	6 / 0.2 / 0.12
Minimum switching load	mW (V/mA)	50 (5 / 2)
Standard contact material		AgNi + Au
Supply specification		
Nominal voltage (U_N)	V DC/AC	6 - 12 - 24 - 110...125
	V AC (50/60 Hz)	220...240
Rated power	VA (50 Hz)/W	See coil specifications page 16
Operating range		(0.8...1.1) U_N
Holding voltage		0.6 U_N
Must drop-out voltage		0.1 U_N
Technical data		
Mechanical life AC/DC	cycles	$10 \cdot 10^6$
Electrical life at rated load AC1	cycles	$60 \cdot 10^3$
Operate/release time	ms	5 / 6
Insulation between coil and contacts (1.2/50 μ s)	kV	6 (8 mm)
Dielectric strength between open contacts	V AC	1,000
Ambient temperature range	$^{\circ}$ C	-40...+70
Protection category		IP20
Approvals relay (according to type)		CE

MasterINPUT - SSR

Features

1 Pole interface modules, 6.2 mm wide, ideal for PLC and electronic systems

- Jumper link option for the quick and easy distribution of supply voltage to proximity switches and similar input devices (Bus-bar connection BB)
- Accepts output fuse module **093.63** (for 5 x 20 mm fuses) for quick and easy load protection, see page 22

39.40
Screw terminal



NEW 39.40



- 0.1 or 2 A solid state relay
- 6 - 12 V DC, 24 - 125 V AC/DC and 230 V AC supply
- 35 mm rail (EN 60715) mounting

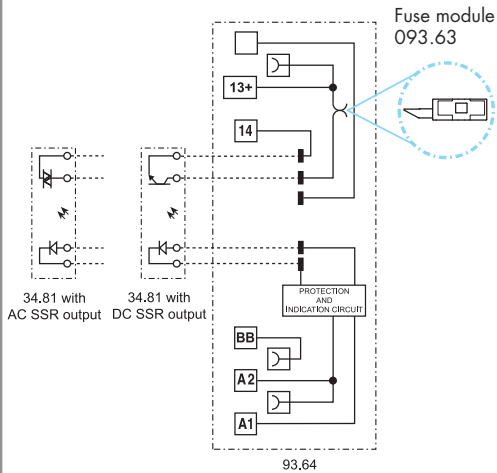

For outline drawing see page 20

Output specification (SSR)	39.40.x.xxx.9024	39.40.x.xxx.7048	39.40.x.xxx.8240
Contact configuration	1 NO (SPST-NO)		
Rated current/Maximum peak current (10 ms) A	2/20 DC	0.1/0.5 DC	2/40 AC
Rated voltage/Maximum blocking voltage V	24/33 DC	48/60 DC	240/275 AC
Switching voltage range V	(1.5...24) DC	(1.5...48) DC	(12...240) AC
Minimum switching current mA	1	0.05	22
Max. "OFF-state" leakage current mA	0.001	0.001	1.5
Max. "ON-state" voltage drop V	0.12	1	1.6
Supply specification			
Nominal voltage (U _N)	V DC/AC	24 - 110...125	
	V AC (50/60 Hz)	220...240	
	V DC	6 - 12	
Rated power VA (50 Hz) / W	See input specifications page 17		
Operating range	(0.8...1.1) U _N		
Must drop-out voltage	0.1 U _N		
Technical data			
Operate/release time ms	0.2/0.6	0.04/0.11	12/12
Dielectric strength between input/output V AC	2,500		
Ambient temperature range °C	-20...+55		
Protection category	IP20		
Approvals relay (according to type)	CE		

MasterOUTPUT - EMR

Features

1 Pole interface modules, 6.2 mm wide, ideal for PLC and electronic systems

- Jumper link option for the quick and easy distribution of supply voltage to output side (Bus-bar connection BB) and its connection to electromagnetic valves and similar output devices

39.21
Screw terminal



NEW 39.21



- 6 A electromechanical relay
- 6 - 12 - 24 - 125 V AC/DC and 230 V AC supply
- 35 mm rail (EN 60715) mounting

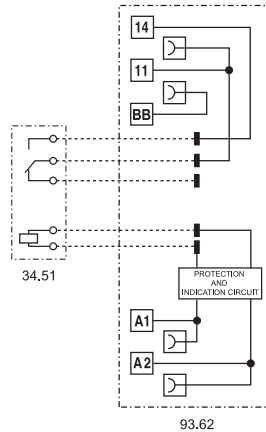

For outline drawing see page 20

Contact specification		
Contact configuration		1 NO (SPST-NO)
Rated current/Maximum peak current	A	6 / 10
Rated voltage/Maximum switching voltage	V AC	250 / 400
Rated load AC1	VA	1,500
Rated load AC15 (230 V AC)	VA	300
Single phase motor rating (230 V AC)	kW	0.185
Breaking capacity DC1: 30/110/220 V	A	6 / 0.2 / 0.12
Minimum switching load	mW (V/mA)	500 (12 / 10)
Standard contact material		AgNi
Supply specification		
Nominal voltage (U_N)	V DC/AC	6 - 12 - 24 - 110...125
	V AC (50/60 Hz)	220...240
Rated power	VA (50 Hz)/W	See coil specifications page 16
Operating range		$(0.8...1.1) U_N$
Holding voltage		$0.6 U_N$
Must drop-out voltage		$0.1 U_N$
Technical data		
Mechanical life AC/DC	cycles	$10 \cdot 10^6$
Electrical life at rated load AC1	cycles	$60 \cdot 10^3$
Operate/release time	ms	5 / 6
Insulation between coil and contacts (1.2/50 μ s)	kV	6 (8 mm)
Dielectric strength between open contacts	V AC	1,000
Ambient temperature range	$^{\circ}$ C	-40...+70
Protection category		IP20
Approvals relay (according to type)		

MasterOUTPUT - SSR

Features

1 Pole interface modules, 6.2 mm wide, ideal for PLC and electronic systems

- Jumper link option for the quick and easy distribution of supply voltage to output side (Bus-bar connection BB) and its connection to electromagnetic valves and similar output devices

39.20
Screw terminal



NEW 39.20



- 0.1 or 2 A solid state relay
- 6 to 24 V DC, 125 V AC/DC and 230 V AC supply
- 35 mm rail (EN 60715) mounting

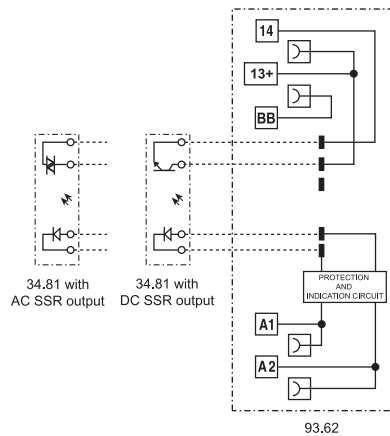

For outline drawing see page 20

Output specification (SSR)	39.20.x.xxx.9024	39.20.x.xxx.7048	39.20.x.xxx.8240
Contact configuration	1 NO (SPST-NO)		
Rated current/Maximum peak current (10 ms) A	2/20 DC	0.1/0.5 DC	2/40 AC
Rated voltage/Maximum blocking voltage V	24/33 DC	48/60 DC	240/275 AC
Switching voltage range V	(1.5...24) DC	(1.5...48) DC	(12...240) AC
Minimum switching current mA	1	0.05	22
Max. "OFF-state" leakage current mA	0.001	0.001	1.5
Max. "ON-state" voltage drop V	0.12	1	1.6
Supply specification			
Nominal voltage (U _N)	V DC/AC	110...125	
	V AC (50/60 Hz)	220...240	
	V DC	6 - 12 - 24	
Rated power VA (50 Hz) / W	See input specifications page 17		
Operating range	(0.8...1.1) U _N		
Must drop-out voltage	0.1 U _N		
Technical data			
Operate/release time ms	0.2/0.6	0.04/0.11	12/12
Dielectric strength between input/output V AC	2,500		
Ambient temperature range °C	-20...+55		
Protection category	IP20		
Approvals relay (according to type)	CE		

MasterTIMER - EMR

Features

Slim timed interface module, 6.2 mm wide, ideal for space-saving timing solutions in panels

- Timer adjustment via top mounted rotary knob, accessible after assembly
- Control signal terminal
- DIP-switch for selection of 4 time scales and 8 functions
- Accepts output fuse module **093.63** (for 5 x 20 mm fuses) for quick and easy load protection, see page 22
- Common connection possible with optional jumper links (terminals A1, A2 and 15)

NEW 39.81



- 6 A electromechanical relay
- 12 - 24 V AC/DC supply
- 35 mm rail (EN 60715) mounting

39.81
Screw terminal

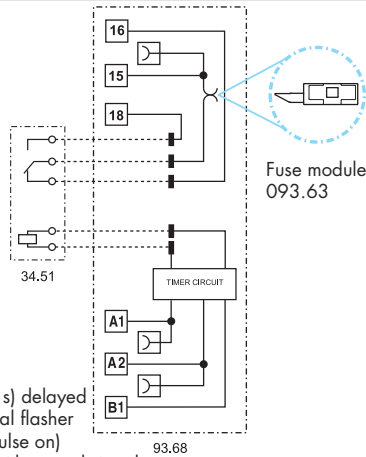

- AI:** On-delay
- DI:** Interval
- GI:** Pulse (0.5 s) delayed
- SW:** Symmetrical flasher (starting pulse on)
- BE:** Off-delay with control signal
- CE:** On- and off-delay with control signal
- DE:** Interval with control signal on
- EE:** Interval with control signal off

For outline drawing see page 20

Contact specification		
Contact configuration		1 CO (SPDT)
Rated current/Maximum peak current	A	6 / 10
Rated voltage/Maximum switching voltage	V AC	250 / 400
Rated load AC1	VA	1,500
Rated load AC15 (230 V AC)	VA	300
Single phase motor rating (230 V AC)	kW	0.185
Breaking capacity DC1: 30/110/220 V	A	6 / 0.2 / 0.12
Minimum switching load	mW (V/mA)	500 (12 / 10)
Standard contact material		AgNi
Supply specification		
Nominal voltage (U_N)	V AC/DC	12 - 24
Rated power AC / DC	VA (50 Hz)/W	See coil specifications page 16
Operating range		$(0.8...1.1) U_N$
Holding voltage		$0.6 U_N$
Must drop-out voltage		$0.1 U_N$
Technical data		
Specified time range		$(0.1...3)s, (3...60)s, (1...20)min, (0.3...6)h$
Repeatability	%	± 1
Recovery time	ms	≤ 50
Minimum control impulse	ms	50
Setting accuracy - full range	%	5
Electrical life at rated load AC1	cycles	$60 \cdot 10^3$
Ambient temperature range	$^{\circ}C$	$-20...+50$
Protection category		IP20
Approvals relay (according to type)		CE

MasterTIMER - SSR

Features

Slim timed interface module, 6.2 mm wide, ideal for space-saving timing solutions in panels

- Timer adjustment via top mounted rotary knob; accessible after assembly
- Start terminal
- DIP-switch for selection of 4 time scales and 8 functions
- Accepts output fuse module **093.63** (for 5 x 20 mm fuses) for quick and easy load protection, see page 22
- Common connection possible with optional jumper links (terminals A1, A2 and 15+)

NEW 39.80



- 0.1 or 2 A solid state relay
- 12 - 24 V AC/DC supply
- 35 mm rail (EN 60715) mounting

39.80
Screw terminal

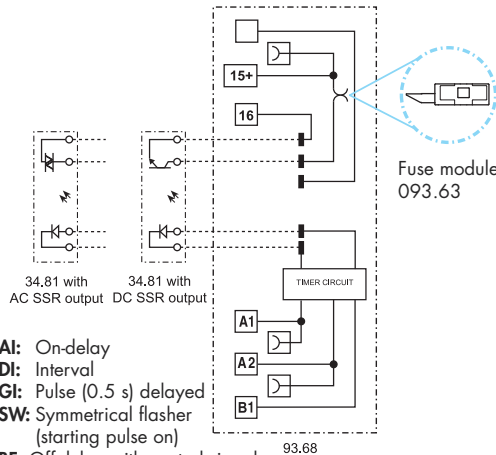

- A1:** On-delay
DI: Interval
GI: Pulse (0.5 s) delayed
SW: Symmetrical flasher (starting pulse on)
BE: Off-delay with control signal
CE: On- and off-delay with control signal
DE: Interval with control signal on
EE: Interval with control signal off

For outline drawing see page 20

Output specification (SSR)	39.80.x.xxx.9024	39.80.x.xxx.7048	39.80.x.xxx.8240
Contact configuration	1 NO (SPST-NO)		
Rated current/Maximum peak current (10 ms) A	2/20 DC	0.1/0.5 DC	2/40 AC
Rated voltage/Maximum blocking voltage V	24/33 DC	48/60 DC	240/275 AC
Switching voltage range V	(1.5...24) DC	(1.5...48) DC	(12...240) AC
Minimum switching current mA	1	0.05	22
Max. "OFF-state" leakage current mA	0.001	0.001	1.5
Max. "ON-state" voltage drop V	0.12	1	1.6
Supply specification			
Nominal voltage (U _N) V AC/DC	12 - 24		
Rated power VA (50 Hz) / W	See input specifications page 17		
Operating range	(0.8...1.1) U _N		
Holding voltage	0.6 U _N		
Must drop-out voltage	0.1 U _N		
Technical data			
Specified time range	(0.1...3)s, (3...60)s, (1...20)min, (0.3...6)h		
Repeatability %	± 1		
Recovery time ms	≤ 50		
Minimum control impulse ms	50		
Setting accuracy – full range %	5		
Ambient temperature range °C	-20...+50		
Protection category	IP20		
Approvals relay (according to type)	CE		

Ordering information

Example: MasterPLUS 39 series screw terminal interface module, electromechanical relay output, 1 CO (SPDT), 24 V AC /DC coil.

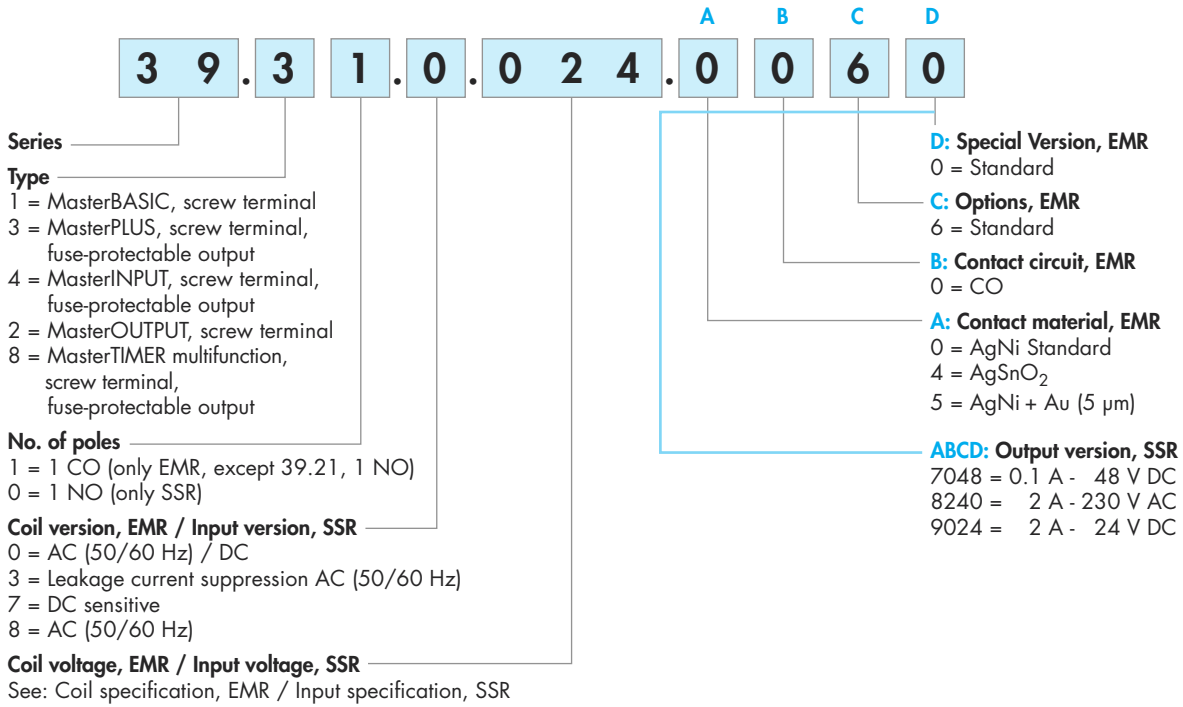

EMR - Selecting features and options: only combinations in the same row are possible.
Preferred selections for best availability are shown in **bold**.

Type	Coil version	A	B	C	D
39.11	0.006 - 0.012 0.024 - 8.230	0 - 4 - 5	0	6	0
39.31	0.006 - 0.012 0.024 - 0.060 0.125 - 8.230 7.125 - 7.220 3.125 - 3.230	0 - 4 - 5	0	6	0
39.41	0.006 - 0.012 0.024 - 0.125 8.230	0 - 4 - 5	0	6	0
39.21	0.006 - 0.012 0.024 - 0.125 8.230	0 - 4 - 5	0	6	0
39.81	0.012 - 0.024	0	0	6	0

SSR - Selecting features and options: only combinations in the same row are possible.
Preferred selections for best availability are shown in **bold**.

Type	Input version	Output version, ABCD
39.10	7.006 - 7.012 7.024 - 8.230	7048 - 8240 - 9024
39.30	7.006 - 7.012 7.024 - 7.060 7.125 - 7.220 0.024 - 0.125 8.230 3.125 - 3.230	7048 - 8240 - 9024
39.40	7.006 - 7.012 0.024 - 0.125 8.230	7048 - 8240 - 9024
39.20	7.006 - 7.012 7.024 - 0.125 8.230	7048 - 8240 - 9024
39.80	0.012 - 0.024	7048 - 8240 - 9024

Technical data

Insulation according to EN 61810-1			
Nominal voltage of supply system	V AC	230 / 400	
Rated insulation voltage	V AC	250	400
Pollution degree		3	2
Insulation between coil and contact set			
Type of Insulation		Reinforced	
Overtension category		III	
Rated impulse voltage	kV (1.2/50) μ s	6	
Dielectric strength	V AC	4,000	
Insulation between open contacts (EMR)			
Type of disconnection		Micro-disconnection	
Dielectric strength	V AC / kV (1.2/50) μ s	1,000 / 1.5	
Conducted disturbance immunity			
		$U_N \leq 60$ V	$U_N = 125$ V
Fast transients (burst 5/50 ns, 5 kHz) according to EN 61000-4-4 at supply terminals		4 kV	4 kV
Voltage pulses (surge 1.2/50 μ s) according to EN 61000-4-5 at supply terminals (differential mode)		0.8 kV	2 kV
			$U_N = 230$ V
			4 kV
Other data			
Bounce time (EMR) : NO/NC	ms	1/6	
Vibration resistance (EMR, 10..55 Hz): NO/NC	g	10/5	
Power lost to the environment	without contact current	W 0.2 (24 V) – 0.4 (230 V)	
	with rated current	W 0.6 (24 V) – 0.9 (230 V)	
Terminals			
Wire strip length	mm	10	
Screw torque	Nm	0.5	
		Solid and stranded cable	
Max. wire size	mm ²	1 x 2.5 / 2 x 1.5	
	AWG	1 x 14 / 2 x 16	
Min. wire size	mm ²	1 x 0.2	
	AWG	1 x 24	

Contact specification (EMR)

F 39 - Electrical life (AC) v contact current

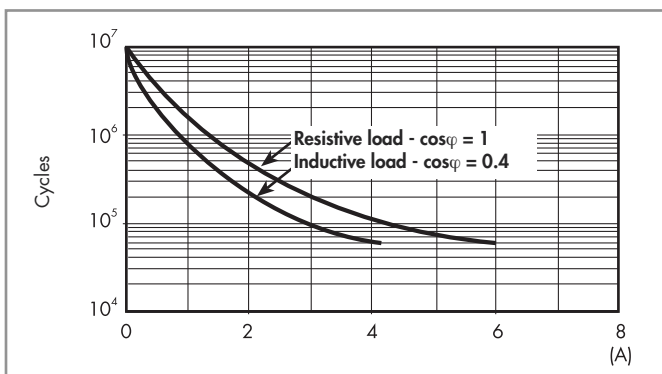

H 39 - Maximum DC1 breaking capacity

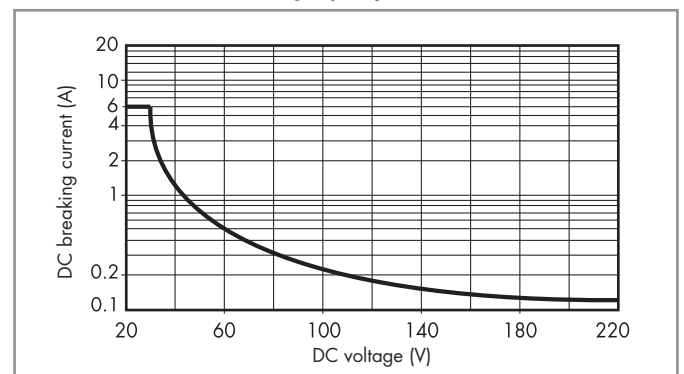

- When switching a resistive load (DC1) having voltage and current values under the curve, an electrical life of $\geq 60 \cdot 10^3$ can be expected.
- In the case of DC13 loads, the connection of a diode in parallel with the load will permit a similar electrical life as for a DC1 load.
Note: the release time for the load will be increased.

Coil specifications - Electromechanical Relay

Coil data sensitive DC, type 39.31

Nominal voltage U_N V	Coil code	Operating range		Must drop-out voltage U_r V	Rated input current at U_N I_N mA	Rated power at U_N W
		U_{min} V	U_{max} V			
125 (110...125)	7.125	88	138	12.5	4.6	0.6
220	7.220	176	242	22	3.0	0.6

Coil data AC/DC, type 39.11/21/31/41

Nominal voltage U_N V	Coil code	Operating range		Must drop-out voltage U_r V	Rated input current at U_N I_N mA	Rated power at U_N VA / W
		U_{min} V	U_{max} V			
6	0.006	4.8	6.6	0.6	35	0.2 / 0.2
12	0.012	9.6	13.2	1.2	15	0.2 / 0.2
24	0.024	19.2	26.4	2.4	11	0.25 / 0.25
60 ⁽¹⁾	0.060	48	66	6.0	5.7	0.35 / 0.35
125 ⁽²⁾ (110...125)	0.125	88	138	12.5	5.6	0.7 / 0.7

⁽¹⁾ 60 V AC/DC for type 39.31 only

⁽²⁾ 125 V AC/DC for types 39.21/31/41 only

Coil data AC, type 39.11/21/31/41

Nominal voltage U_N V	Coil code	Operating range		Must drop-out voltage U_r V	Rated input current at U_N I_N mA	Rated power at U_N VA / W
		U_{min} V	U_{max} V			
230 (230..240)	8.230	184	264	23	4.3	1 / 0.4

Coil data leakage current suppression versions, type 39.31.3

Nominal voltage U_N V	Coil code	Operating range		Must drop-out voltage U_r V	Rated input current at U_N I_N mA	Rated power at U_N VA / W
		U_{min} V	U_{max} V			
125 (110...125)	3.125	88	138	44	8.4	1.1 / 1
230 (230..240)	3.230	184	264	72	5.9	1.4 / 0.5

The 39 Series interface modules (supply version 3) have built-in leakage current suppression to address industry concerns of the contacts not dropping-out when there is residual current in the circuit; at (110...125)V AC and (230...240)V AC.

This problem can occur, for example, when connecting the interface modules to PLC,s with triac outputs or when connecting via relatively long cables.

Coil data AC/DC timer, type 39.81

Nominal voltage U_N V	Coil code	Operating range (AC/DC)		Must drop-out voltage U_r V	Rated input current at U_N		Rated power at U_N	
		U_{min} V	U_{max} V		DC	AC	DC	AC
					mA	mA	W	VA / W
12	0.012	9.6	13.2	1.2	15	23	0.2	0.3 / 0.2
24	0.024	19.2	26.4	2.4	11	19	0.25	0.4 / 0.3

Input specifications - Solid State Relay

Input data sensitive DC, type 39.10/20/30/40

Nominal voltage U_N	Input code	Operating range		Must drop-out voltage U_r	Rated input current at U_N I_N	Rated power at U_N W
		U_{min}	U_{max}			
V		V	V	V	mA	W
6	7.006	4.8	6.6	0.6	7.5	0.2
12	7.012	9.6	13.2	1.2	20.7	0.25
24 ⁽¹⁾	7.024	19.2	26.4	2.4	10.5	0.25
60 ⁽²⁾	7.060	48	66	6.0	6.4	0.4
125 ⁽²⁾ (110...125)	7.125	88	138	12.5	4.6	0.6
220 ⁽²⁾	7.220	176	242	22	3.0	0.6

⁽¹⁾ 24 V DC for type 39.10/20/30 only

⁽²⁾ 60 V DC, 125 V DC and 220 V DC for type 39.30 only

Input data AC/DC, type 39.20/30/40

Nominal voltage U_N	Input code	Operating range		Must drop-out voltage U_r	Rated input current at U_N I_N	Rated power at U_N VA / W
		U_{min}	U_{max}			
V		V	V	V	mA	VA / W
24 ⁽³⁾	0.024	19.2	26.4	2.4	17.5	0.4 / 0.3
125 (110...125)	0.125	88	138	12.5	5.5	0.7 / 0.7

⁽³⁾ 24 V AC/DC for type 39.30/40 only

Input data AC, type 39.10/20/30/40

Nominal voltage U_N	Input code	Operating range		Must drop-out voltage U_r	Rated input current at U_N I_N	Rated power at U_N VA / W
		U_{min}	U_{max}			
V		V	V	V	mA	VA / W
230 (230...240)	8.230	184	264	23	4.2	1 / 0.4

Input data leakage current suppression versions, type 39.30.3

Nominal voltage U_N	Input code	Operating range		Must drop-out voltage U_r	Rated input current at U_N I_N	Rated power at U_N VA / W
		U_{min}	U_{max}			
V		V	V	V	mA	VA / W
125 (110...125)	3.125	88	138	44	8.4	1.1 / 1
230 (230...240)	3.230	184	264	72	5.9	1.4 / 0.5

The 39 Series interface modules (supply version 3) have built-in leakage current suppression to address industry concerns of the contacts not dropping-out when there is residual current in the circuit; at (110...125)V AC and (230...240)V AC.

This problem can occur, for example, when connecting the interface modules to PLC,s with triac outputs or when connecting via relatively long cables.

Input data AC/DC timer, type 39.80

Nominal voltage U_N	Input code	Operating range (AC/DC)		Must drop-out voltage U_r	Rated input current at U_N		Rated power at U_N	
		U_{min}	U_{max}		DC	AC	DC	AC
V		V	V	V	mA	mA	W	VA / W
12	0.012	9.6	13.2	1.2	15	23	0.2	0.3 / 0.2
24	0.024	19.2	26.4	2.4	11	19	0.25	0.4 / 0.3

Timer specifications

EMC specifications

Type of test		Reference standard	
Electrostatic discharge	contact discharge	EN 61000-4-2	4 kV
	air discharge	EN 61000-4-2	8 kV
Radio-frequency electromagnetic field	(80 ÷ 1,000 MHz)	EN 61000-4-3	10 V/m
	(1,400 ÷ 2,700 MHz)	EN 61000-4-3	10 V/m
Fast transients (burst) (5-50 ns, 5 and 100 kHz)	on Supply terminals	EN 61000-4-4	4 kV
	on control signal terminals	EN 61000-4-4	4 kV
Surges (1.2/50 µs) on supply and control signal terminals	common mode	EN 61000-4-5	2 kV
	differential mode	EN 61000-4-5	0.8 kV
Radio-frequency common mode (0.15 ÷ 80 MHz)	on Supply terminals	EN 61000-4-6	10 V
	on control signal terminals	EN 61000-4-6	3 V
Radiated and conducted emission		EN 55022	class B

Other data

Bounce time (EMR) : NO/NC	ms	1/6	
Vibration resistance (EMR, 10..55 Hz): NO/NC	g	10/5	
Power lost to the environment	without contact current	W	0.3
	with rated current	W	0.8

Terminals

Wire strip length	mm	10
Screw torque	Nm	0.5
Solid and stranded cable		
Max. wire size	mm ²	1 x 2.5 / 2 x 1.5
	AWG	1 x 14 / 2 x 16
Min. wire size	mm ²	1 x 0.2
	AWG	1 x 24

Times scales



Functions

LED	Supply voltage	NO contact/output
	OFF	Open
	ON	Open
	ON	Open (timing to close in progress)
	ON	Closed

Wiring diagram

U = Supply voltage

S = Signal switch

 = Output contact

Without control signal

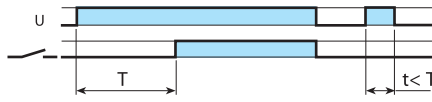
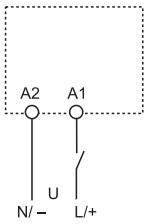

(AI) On-delay
Apply power to timer.
Output contacts transfer after preset time has elapsed. Reset occurs when power is removed.

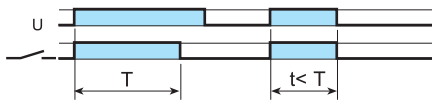

(DI) Interval
Apply power to timer.
Output contacts transfer immediately. After the preset time has elapsed, contacts reset.

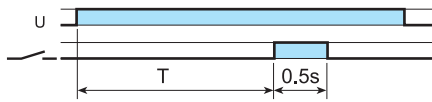

(GI) Pulse (0.5s) delayed
Apply power to timer.
Output contacts transfer after preset time has elapsed. Reset occurs after a fixed time of 0.5s.

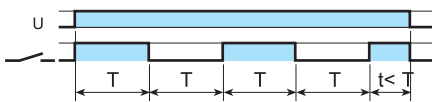

(SW) Symmetrical flasher (starting pulse on)
Apply power to timer.
Output contacts transfer immediately and cycle between ON and OFF for as long as power is applied. The ratio is 1:1 (time on = time off).

With control signal

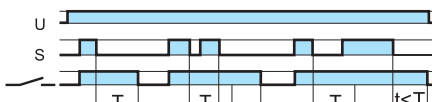
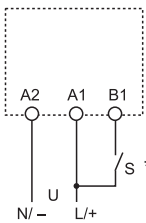

(BE) Off-delay with control signal
Power is permanently applied to the timer. The output contacts transfer immediately on closure of the Signal Switch (S). Opening the Signal Switch initiates the preset delay, after which time the output contacts reset.



(CE) On- and off-delay with control signal
Power is permanently applied to the timer. Closing the Signal Switch (S) initiates the preset delay, after which time the output contacts transfer. Opening the Signal switch initiates the same preset delay, after which time the output contacts reset.



(DE) Interval with control signal on
Power is permanently applied to the timer. On momentary or maintained closure of Signal Switch (S), the output contacts transfer, and remain so for the duration of the preset delay, after which they reset.



(EE) Interval with control signal off
Power is permanently applied to the timer. On opening of the Signal Switch (S) the output contacts transfer, and remain so for the duration of the preset delay, after which they reset.

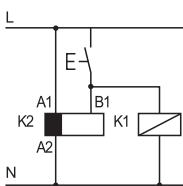

• Possible to control an external load, such as another relay coil or timer, connected to the signal start terminal B1.

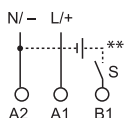

** A voltage other than the supply voltage can be applied to the command Start (B1), example:

A1 - A2 = 24 V AC
B1 - A2 = 12 V DC

Outline drawings

39.10
39.11
Screw terminal

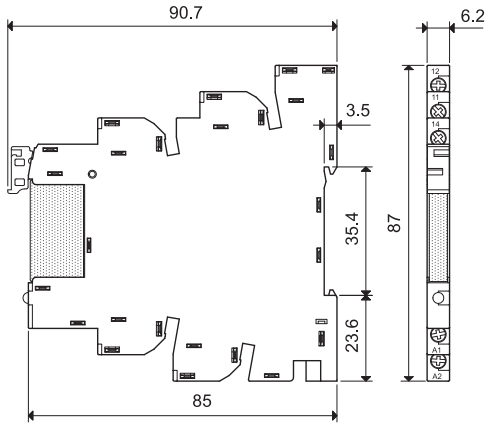

39.20
39.21
Screw terminal

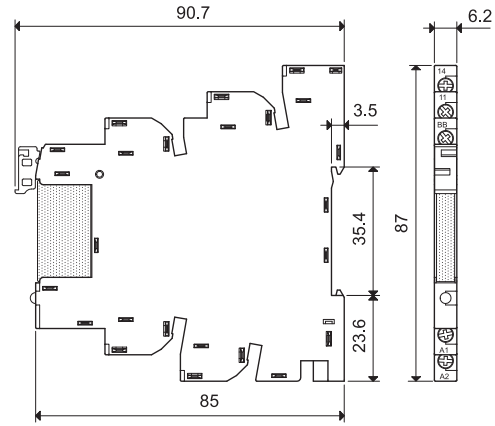

39.30 / 39.30.3
39.31 / 39.31.3
Screw terminal

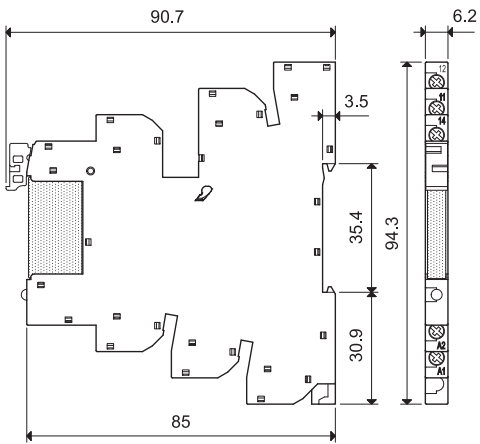

39.40
39.41
Screw terminal

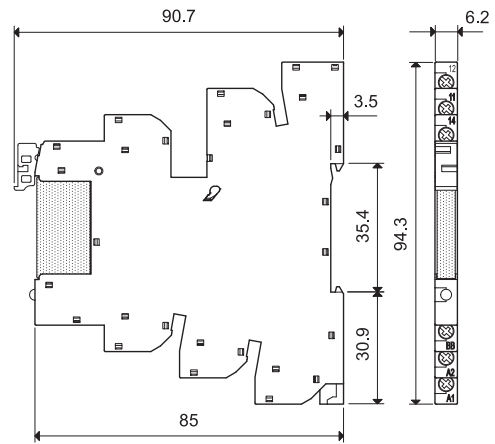

39.80
39.81
Screw terminal

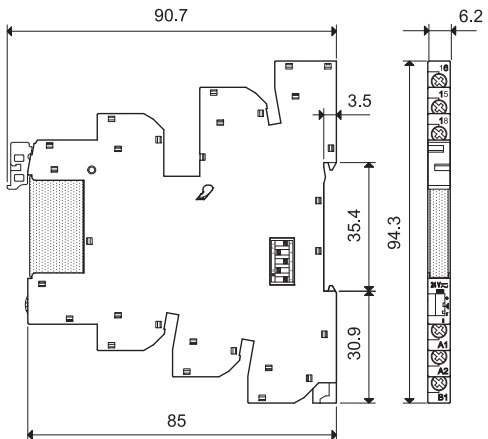

Electromechanical Relay (1 Pole 6 A) & Socket Combinations

Interface Module Code	Coil voltage	Relay	Socket
MasterBASIC			
39.11.0.006.0060	6 V AC/DC	34.51.7.005.0010	93.61.7.024
39.11.0.012.0060	12 V AC/DC	34.51.7.012.0010	93.61.7.024
39.11.0.024.0060	24 V AC/DC	34.51.7.024.0010	93.61.7.024
39.11.8.230.0060	(230...240)V AC	34.51.7.060.0010	93.61.8.230
MasterPLUS			
39.31.0.006.0060	6 V AC/DC	34.51.7.005.0010	93.63.7.024
39.31.0.012.0060	12 V AC/DC	34.51.7.012.0010	93.63.7.024
39.31.0.024.0060	24 V AC/DC	34.51.7.024.0010	93.63.7.024
39.31.0.060.0060	60 V AC/DC	34.51.7.060.0010	93.63.7.060
39.31.0.125.0060	(110...125)V AC/DC	34.51.7.060.0010	93.63.0.125
39.31.8.230.0060	(230...240)V AC	34.51.7.060.0010	93.63.8.230
39.31.7.125.0060	(110...125)V DC	34.51.7.060.0010	93.63.7.125
39.31.7.220.0060	220 V DC	34.51.7.060.0010	93.63.7.220
39.31.3.125.0060	(110...125)V AC	34.51.7.060.0010	93.63.3.125
39.31.3.230.0060	(230...240)V AC	34.51.7.060.0010	93.63.3.230
MasterINPUT			
39.41.0.006.5060	6 V AC/DC	34.51.7.005.5010	93.64.0.024
39.41.0.012.5060	12 V AC/DC	34.51.7.012.5010	93.64.0.024
39.41.0.024.5060	24 V AC/DC	34.51.7.024.5010	93.64.0.024
39.41.0.125.5060	(110...125) V AC/DC	34.51.7.060.5010	93.64.0.125
39.41.8.230.5060	(230...240)V AC	34.51.7.060.5010	93.64.8.230
MasterOUTPUT			
39.21.0.006.0060	6 V AC/DC	34.51.7.005.0010	93.62.7.024
39.21.0.012.0060	12 V AC/DC	34.51.7.012.0010	93.62.7.024
39.21.0.024.0060	24 V AC/DC	34.51.7.024.0010	93.62.7.024
39.21.0.125.0060	(110...125) V AC/DC	34.51.7.060.0010	93.62.0.125
39.21.8.230.0060	(230...240)V AC	34.51.7.060.0010	93.62.8.230
MasterTIMER			
39.81.0.012.0060	12 V AC/DC	34.51.7.012.0010	93.68.0.024
39.81.0.024.0060	24 V AC/DC	34.51.7.024.0010	93.68.0.024

Solid State Relay (1 Pole 0.1 or 2 A) & Socket Combinations

Interface Module Code	Input voltage	Relay	Socket
MasterBASIC			
39.10.7.006.xxxx	6 V DC	34.81.7.005.xxxx	93.61.7.024
39.10.7.012.xxxx	12 V DC	34.81.7.012.xxxx	93.61.7.024
39.10.7.024.xxxx	24 V DC	34.81.7.024.xxxx	93.61.7.024
39.10.8.230.xxxx	(230...240)V AC	34.81.7.060.xxxx	93.61.8.230
MasterPLUS			
39.30.7.006.xxxx	6 V DC	34.81.7.005.xxxx	93.63.7.024
39.30.7.012.xxxx	12 V DC	34.81.7.012.xxxx	93.63.7.024
39.30.7.024.xxxx	24 V DC	34.81.7.024.xxxx	93.63.7.024
39.30.7.060.xxxx	60 V DC	34.81.7.060.xxxx	93.63.7.060
39.30.7.125.xxxx	(110...125)V DC	34.81.7.060.xxxx	93.63.7.125
39.30.7.220.xxxx	220 V DC	34.81.7.060.xxxx	93.63.7.220
39.30.0.024.xxxx	24 V AC/DC	34.81.7.024.xxxx	93.63.0.024
39.30.0.125.xxxx	(110...125)V AC/DC	34.81.7.060.xxxx	93.63.0.125
39.30.8.230.xxxx	(230...240)V AC	34.81.7.060.xxxx	93.63.8.230
39.30.3.125.xxxx	(110...125)V AC	34.81.7.060.xxxx	93.63.3.125
39.30.3.230.xxxx	(230...240)V AC	34.81.7.060.xxxx	93.63.3.230
MasterINPUT			
39.40.7.006.xxxx	6 V DC	34.81.7.005.xxxx	93.64.0.024
39.40.7.012.xxxx	12 V DC	34.81.7.012.xxxx	93.64.0.024
39.40.0.024.xxxx	24 V AC/DC	34.81.7.024.xxxx	93.64.0.024
39.40.0.125.xxxx	(110...125) V AC/DC	34.81.7.060.xxxx	93.64.0.125
39.40.8.230.xxxx	(230...240)V AC	34.81.7.060.xxxx	93.64.8.230
MasterOUTPUT			
39.20.7.006.xxxx	6 V DC	34.81.7.005.xxxx	93.62.7.024
39.20.7.012.xxxx	12 V DC	34.81.7.012.xxxx	93.62.7.024
39.20.7.024.xxxx	24 V DC	34.81.7.024.xxxx	93.62.7.024
39.20.0.125.xxxx	(110...125) V AC/DC	34.81.7.060.xxxx	93.62.0.125
39.20.8.230.xxxx	(230...240)V AC	34.81.7.060.xxxx	93.62.8.230
MasterTIMER			
39.80.0.012.xxxx	12 V AC/DC	34.81.7.012.xxxx	93.68.0.024
39.80.0.024.xxxx	24 V AC/DC	34.81.7.024.xxxx	93.68.0.024

Example: .xxxx
 .9024
 .7048
 .8240

Accessories



093.63

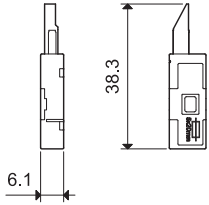

Output fuse module for 39.31/30/41/40/81/80 types

093.63

- Patent-pending solution for easy load protection
- For 5 x 20 mm fuses up to 6 A, 250 V
- Easy visibility of the fuse condition through the window
- Quick connection to socket

Multi-state fuse module

- As delivered, the socket comes without a fuse module. However, the absent fuse is internally replaced with an electrical link - which allows the interface relay to be used without a fuse module. In this state, the peg/indicator is visually hidden (position **A**).
- With fuse module inserted, the fuse is positioned electrically in series with the common output terminal of the interface module (11 for EMR versions, 13+ for SSR versions, 15 for EMR timer, 15+ for SSR timer). This state is indicated by the peg/indicator seen in position **B**.
- If the fuse module is extracted (for example; because the fuse element has blown) the output circuit will be locked open, as this will generally be the "safe option". This state is indicated by the peg/indicator seen in position **C**.
- In order to reinstate the output circuit it is necessary to either re-insert the fuse module (complete with functional fuse), or alternatively, return the peg/indicator to position **A** by gently applying pressure in the direction of the arrow.

0. Peg/indicator in position A (standard on delivered sockets)

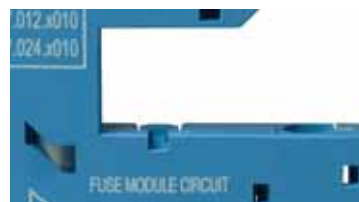

1. Peg/indicator in position B (after fuse module inserted into socket)



2. Peg/indicator in position C (after removal of fuse module from socket)

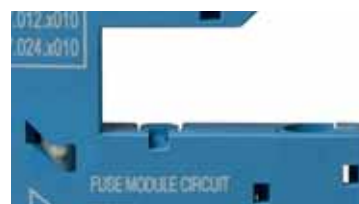

3. Return the peg/indicator to position A



Accessories



093.16



093.16.0



093.16.1

16-way jumper link	093.16 (blue)	093.16.0 (black)	093.16.1 (red)
Rated values	36 A - 250 V		
Possibility of multiple connection, side by side			

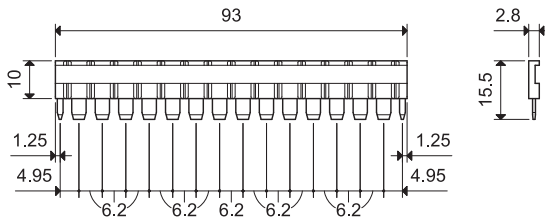

093.60

Dual-purpose plastic separator (1.8 mm or 6.2 mm separation)	093.60
---	--------

1. By breaking off the protruding ribs (by hand), the separator becomes only 1.8 mm thick; useful for the visual separation of different groups of interfaces, or necessary for the protective separation of different voltages of neighbouring interfaces, or for the protection of cut ends of jumper links.



2. Leaving the ribs in place provides 6.2mm separation. Simply cutting (with scissors) the relevant segment(s) permits the interconnection across the separator of 2 different groups of interface relays, using the standard jumper link.

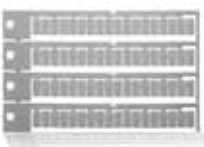
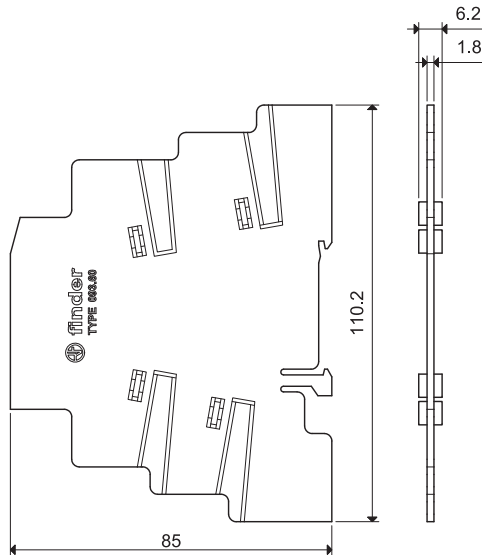

060.72

Sheet of marker tags, plastic, 72 tags, 6x12 mm	060.72
--	--------

