



**P3001-C20/P3001-C10  
P3015-C20/P3015-C2A/P3015-C10/P3015-CG0  
Projected Capacitive Touch Solution  
Datasheet**

Rev. : 1.4

Released date: 2014/02/12

## Preface

### Disclaimer

The information in this document is subject to change without notice. The manufacturer makes no representations or warranties regarding the contents of this manual and specifically disclaims any implied warranties of merchantability or fitness for any particular purpose. Moreover, the manufacturer reserves the right to revise this publication or make changes in the specifications of the product described within it at any time without notice and without obligation to notify any person of such revision.

### Trademarks

AMT is the registered trademark of Apex Material Technology Corp. PenMount is the registered trademark of Salt International Corp. Microsoft, and Windows are registered trademarks of Microsoft Corp. Other product names used in this manual are the properties of their respective owners and are acknowledged.

### Copyright

This publication, including all photographs, illustrations and software, is protected under international copyright laws, with all rights reserved. Neither this manual, nor any of the material contained herein, may be reproduced without the express written consent of the manufacturer.

Copyright 2014 © Apex Material Technology Corp. All rights reserved.

### Revision Table

Date	Revision	Changes
2012/11/02	0.0	Preliminary
2012/11/28	1.0	Interface default
2013/04/19	1.1	Modify Chapter 3.3.2 & Power Consumption
2013/08/22	1.2	Added P3015-CG0 & modify COF tail system block diagram
2013/10/18	1.3	Modify Pin Designation
2014/02/12	1.4	Added P3015-C2A, P3015-C1A, and PM2102 COF

# Table of Content

Preface.....	i
Disclaimer.....	i
Trademarks.....	i
Copyright.....	i
Revision Table.....	i
Table of Content.....	ii
Chapter 1: Scope.....	1
1.1 Products.....	1
1.2 Part no. Definition.....	1
1.3 Serial no. Identification.....	1
Chapter 2: Product Specifications.....	3
2.1 Mechanical Specification.....	3
2.2 Mechanical Dimension.....	4
2.2.1 Touch Panel Mechanical Drawing and Real Product View.....	4
2.2.2 PM2101 COF Tail Mechanical Drawing and Rear/ Front View.....	11
2.2.3 PM2102 COF Tail Mechanical Drawing and Rear/ Front View.....	12
Chapter 3: PM2101 & PM2102 COF Tail Hardware Specifications.....	13
3.1 PM2101 Interface Specifications.....	13
3.2 PM2102 Interface Specifications.....	13
3.3 COF tail System Block Diagram.....	13
3.4 Interface.....	14
3.4.1 USB Interface and Data Communication.....	14
3.4.2 UART Interface and Data Communication.....	14
3.4.3 I <sup>2</sup> C.....	14
3.5 Suggested Connectors on System Side for COF tail terminator.....	15
Chapter 4: PenMount PCI Controller IC Specifications.....	16
4.1 General Descriptions.....	16
4.2 Control IC Features.....	16
4.2.1 Features of PenMount P2-02.....	16
4.2.2 Features of PenMount P2-03.....	16
4.3 Controller IC Pin out.....	17
Chapter 5: Software Drivers & PenMount Utility.....	19
5.1 Available Drivers & Where to Download.....	19
5.2 PCIMSet Introduction.....	19
5.3 Firmware Update.....	20
5.3.1 Firmware Interface.....	20
5.3.2 New Firmware Request.....	20
5.3.3 Firmware download and update.....	20
Chapter 6: Product Test.....	21
6.1 Operating Test.....	21
6.2 Environmental Test.....	21
6.3 ESD.....	21
6.4 Linearity Test.....	21
6.5 Optical Inspection.....	21
6.6 Others.....	21
Chapter 7: Warranty.....	22
Chapter 8: Other Documents.....	22
Chapter 9: Contact Information.....	22

## Chapter 1: Scope

### 1.1 Products

The 3.5" and 4.3" projected capacitive touch panels (AMT named it as 'PCI') with COF (Chip on FPC) tails, their part no. are:

- P3001-C20: 3.5" PCI with 1.1mm plain glass on top
- P3001-C10: 3.5" without top glass, this item is only offered to specific partners
- P3015-C20: 4.3" PCI with 1.1mm plain glass on top
- P3015-C2A: 4.3" PCI with 1.1mm plain glass on top
- P3015-CG0: 4.3" PCI with 1.1mm décor glass on top
- P3015-C10: 4.3" without top glass, this item is only offered to specific partners
- P3015-C1A: 4.3" without top glass, this item is only offered to specific partners

The above touch panels are used different COF tail, the part no. of COF tail is PM2101/PM2102.

### 1.2 Part no. Definition

The entire part number of this PCI products is presented as 92-P30nn-xyz, code "nn" is the sequence number of AMT standard stock PCI items and the last 3 codes of the part number represent which types of tail / glass / version are used and they are shown as follows:

92 - P 3 0 n n - x y z

x Code	Description
C	Use COF tail

y Code	Description
1	No top glass on the PCI touch
2	Use AMT defined plain glass
G	Use décor glass

z Code	Description
0	Version (Using PM2101 COF)
A	Version (Using PM2102 COF)

For example, if the product part no. is P3001-C20, the last three codes represent that PM2101 COF tail, AMT defined plain glass and version 0 are used in this product.

### 1.3 Serial no. Identification

The sticker is on the PCI tail side, it shows the serial no. of this PCI touch panel as the picture below. The example below explains the serial no. representations of AMT's products:

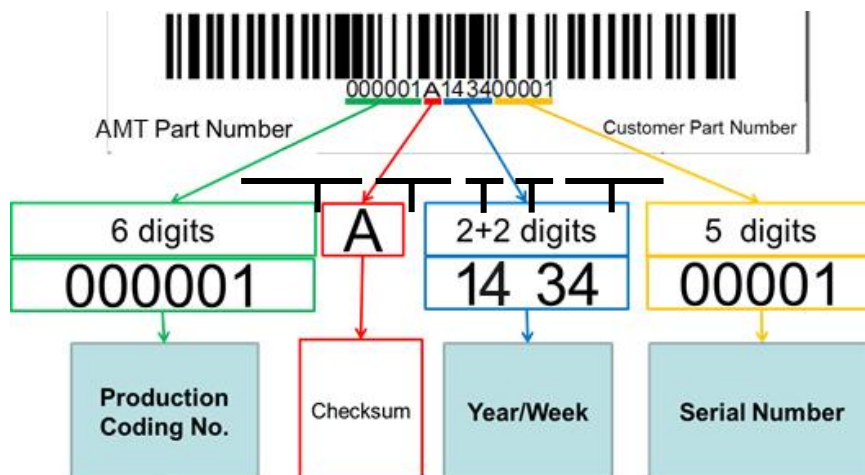

1. As of February 10<sup>th</sup>, 2014, the new bar code has 16 digits in total.
2. The first six digits represent the production coding number of the product. In order to facilitate the ease of tracking for products, all existing valid AMT models will be assigned a unique production coding number when the new bar code system takes effect. In the future, when a new model number is created, a corresponding production coding number will also be assigned to the new model at the same time. The same model will always have the same production coding number. For example, if the touch panel with the part number 92-P3001-C20 is assigned the production coding number 000001, the same model (92-P3001-C20) will still have the same production coding number 000001 in all future batches.
3. The 7<sup>th</sup> digit "Checksum" is an internal check number represented by letters A, S, or T. This number is for AMT's internal check purposes only.
4. The 8<sup>th</sup> and 9<sup>th</sup> digits indicate the year (e.g. 14=2014).  
The 10<sup>th</sup> and 11<sup>th</sup> digits indicate the week (e.g. 34=34<sup>th</sup> week of the year).
5. The last five digits constitute the serial number assigned to each piece of product. Thus, each piece of product will have its own unique identification code, allowing for easy and efficient tracking of all products manufactured by AMT.
6. In the bottom left area indicated by "**AMT Part Number**", the complete 12-digit AMT part number of the product (e.g. 92-P3001-C20) will be printed for quick reference.
7. The bottom right area indicated by "**Customer Part Number**" is an optional function. It is reserved for customers who have needs and request to print their designated part number on the bar code label (maximum 20 digits).

## Chapter 2: Product Specifications

### 2.1 Mechanical Specification

#### Touch Panel Mechanical Specification:

Touch Panel Part No.	P3001-C20	P3001-C10	P3015-C20	P3015-C2A	P3015-CG0	P3015-C10	P3015-C1A
Touch Panel Size	3.5"		4.3"				
Total Thickness (mm)	1.50 ± 0.2	0.40 ± 0.1	1.50 ± 0.2			0.40 ± 0.1	
Thickness of Top glass (mm)	1.1	n/a	1.1			n/a	
Outside Dimension LxW (mm)	87.10 x 71.16	86.1 x 70.16	110.60 x 72.90		121.10 x 85.90	109.60 x 71.90	
View Area LxW (mm)	76.60 x 57.16		100.10 x 58.90		97.10 x 55.90	100.10 x 58.90	
Active Area LxW (mm)	75.60 x 56.16		99.10 x 57.90				
Surface Finish	Clear Type	n/a	Clear Type	Clear Type	Clear Type	n/a	
Haze	7 ±3%						
Light Transmission rate	90 ± 3%						
Construction	GFF	AFF	GFF	GFF	GFF	AFF	AFF

Note: n/a: Not Available    AFF: OCA-Film-Film    GFF: Glass-Film-Film

#### PM2101 COF tail Mechanical Specification:

COF Part No.	PenMount 2101 Flexible Control Board
Support Touch Screen Size	For 3" to 4.9" PCI
Touch Controller	PenMount P2-02
Connector pins & pitch & contact side	10 pins, pitch is 0.5 mm, contact side is down side
Mechanical Size L*W (mm)	57.6 x 38.5
Max. support Sensing Lines	10
Max. support Driving Lines	17

#### PM2102 COF tail Mechanical Specification:

COF Part No.	PenMount 2102 Flexible Control Board
Support Touch Screen Size	For 3" to 4.9" PCI
Touch Controller	PenMount P2-03
Connector pins & pitch & contact side	10 pins, pitch is 0.5 mm, contact side is down side
Mechanical Size L*W (mm)	64.1 x 38.5
Max. support Sensing Lines	10
Max. support Driving Lines	17

## 2.2 Mechanical Dimension

The followings are the drawings of P3001-C20, P3001-C10, P3015-C20, P3015-C2A, P3015-CG0, P3015-C10, P3015-C1A and COF tail. If you need more detailed drawings or information, please visit our website and choose "support & download", click on the item you need and then download.

### 2.2.1 Touch Panel Mechanical Drawing and Real Product View

#### P3001-C20 : 3.5" PCI with 1.1mm top glass

Front View

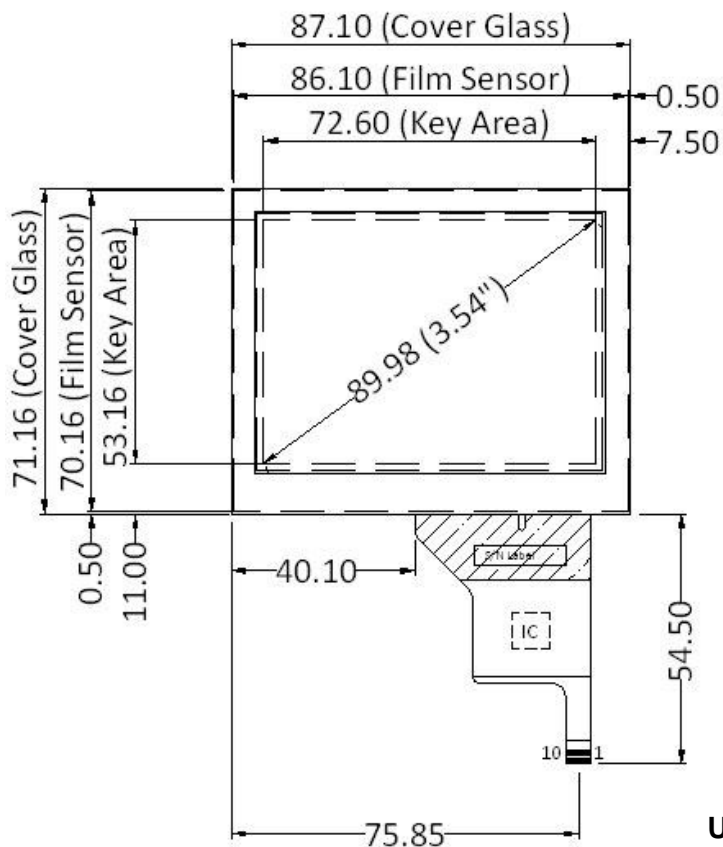
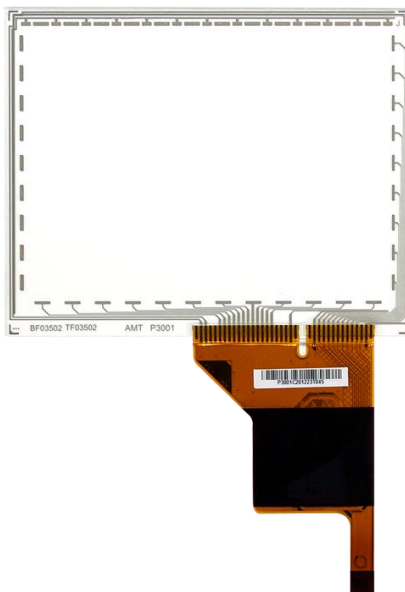

Unit:mm

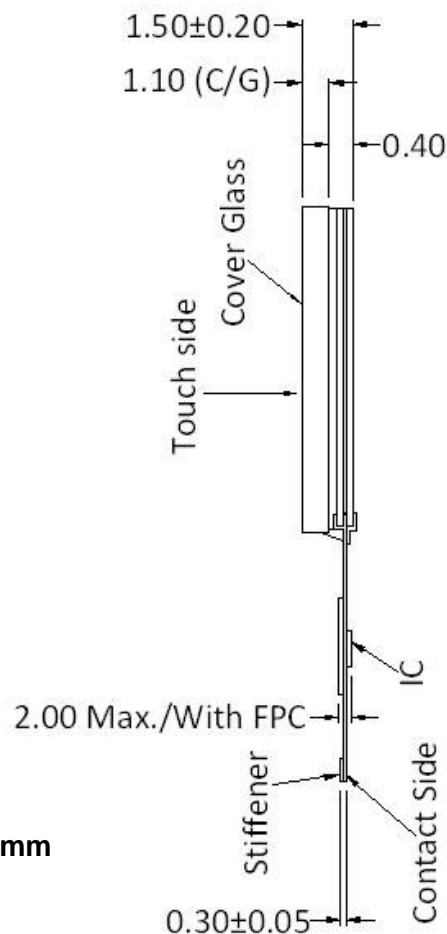

P3001-C10: 3.5" PCI without top glass

Front View

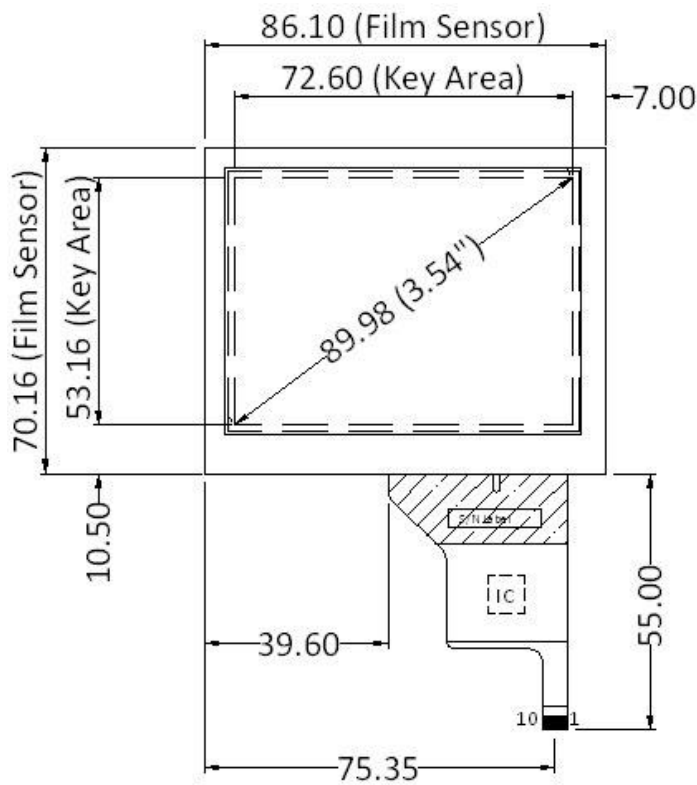
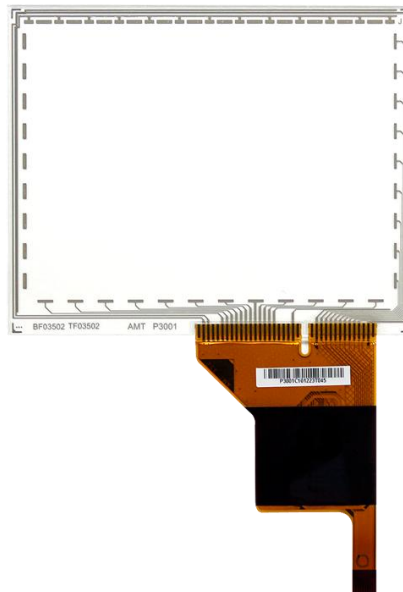

Unit:mm

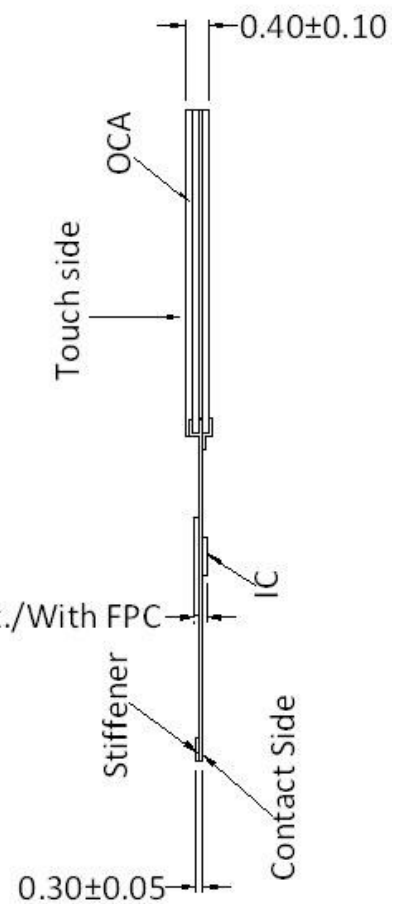

**Remark:** Item P3001-C10 is only available for AMT's selected partners.



P3015-C20 : 4.3" PCI with 1.1mm top glass

Front View

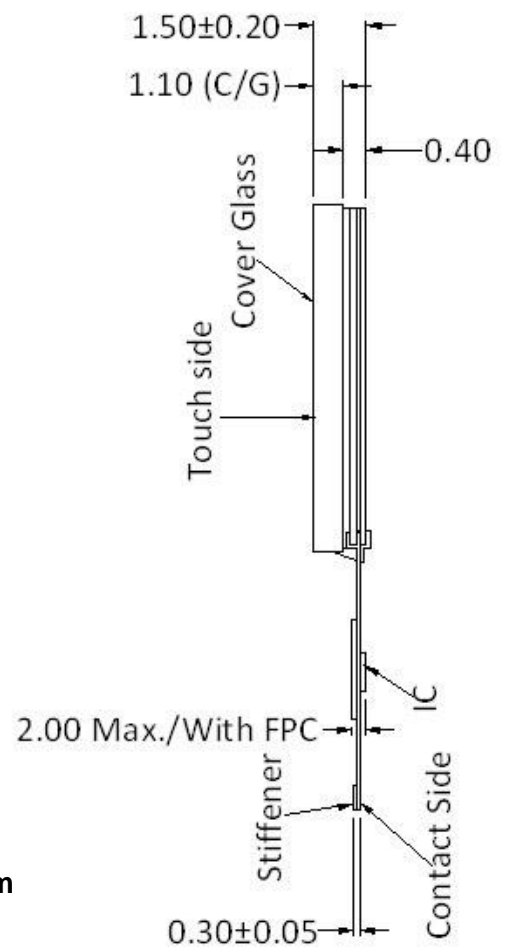
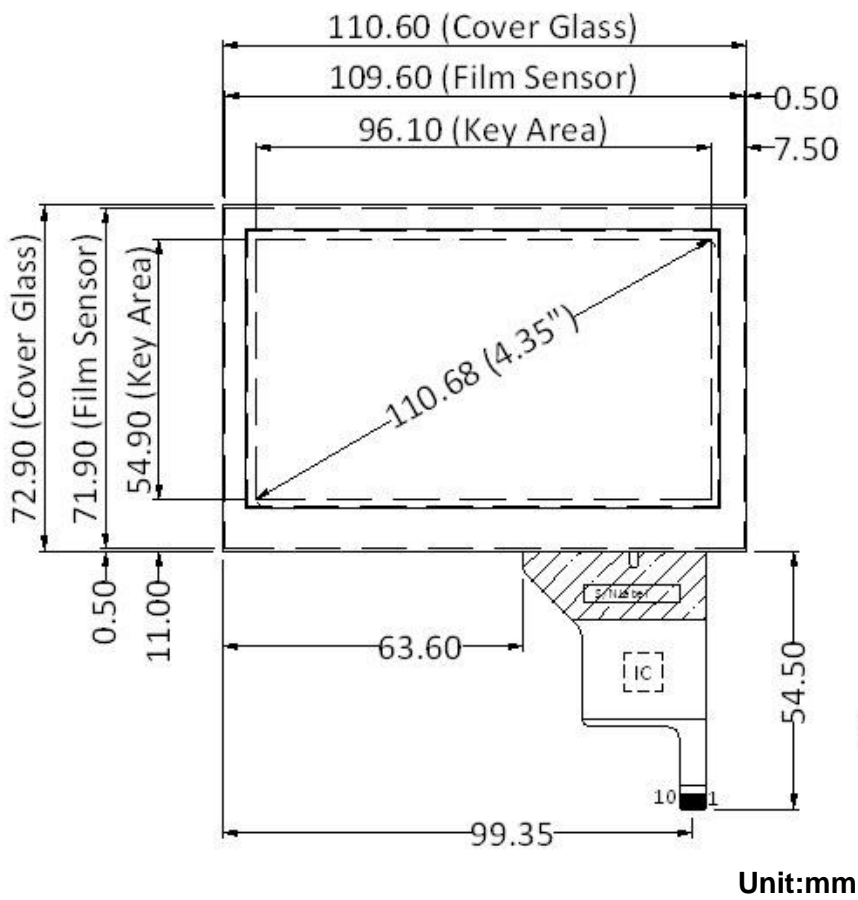
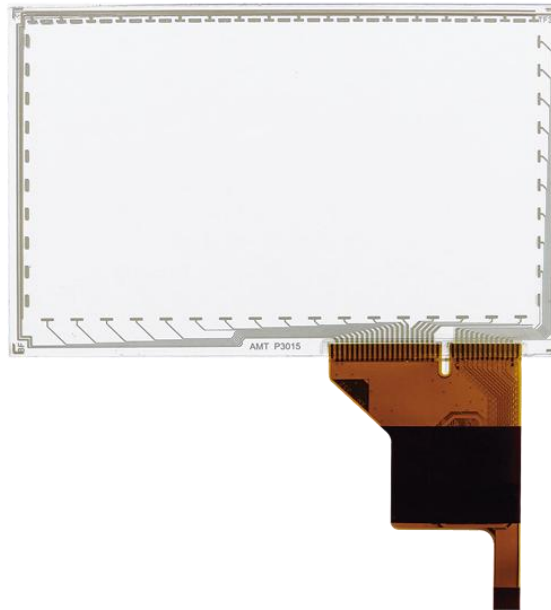

P3015-C2A : 4.3" PCI with 1.1mm top glass

Front View

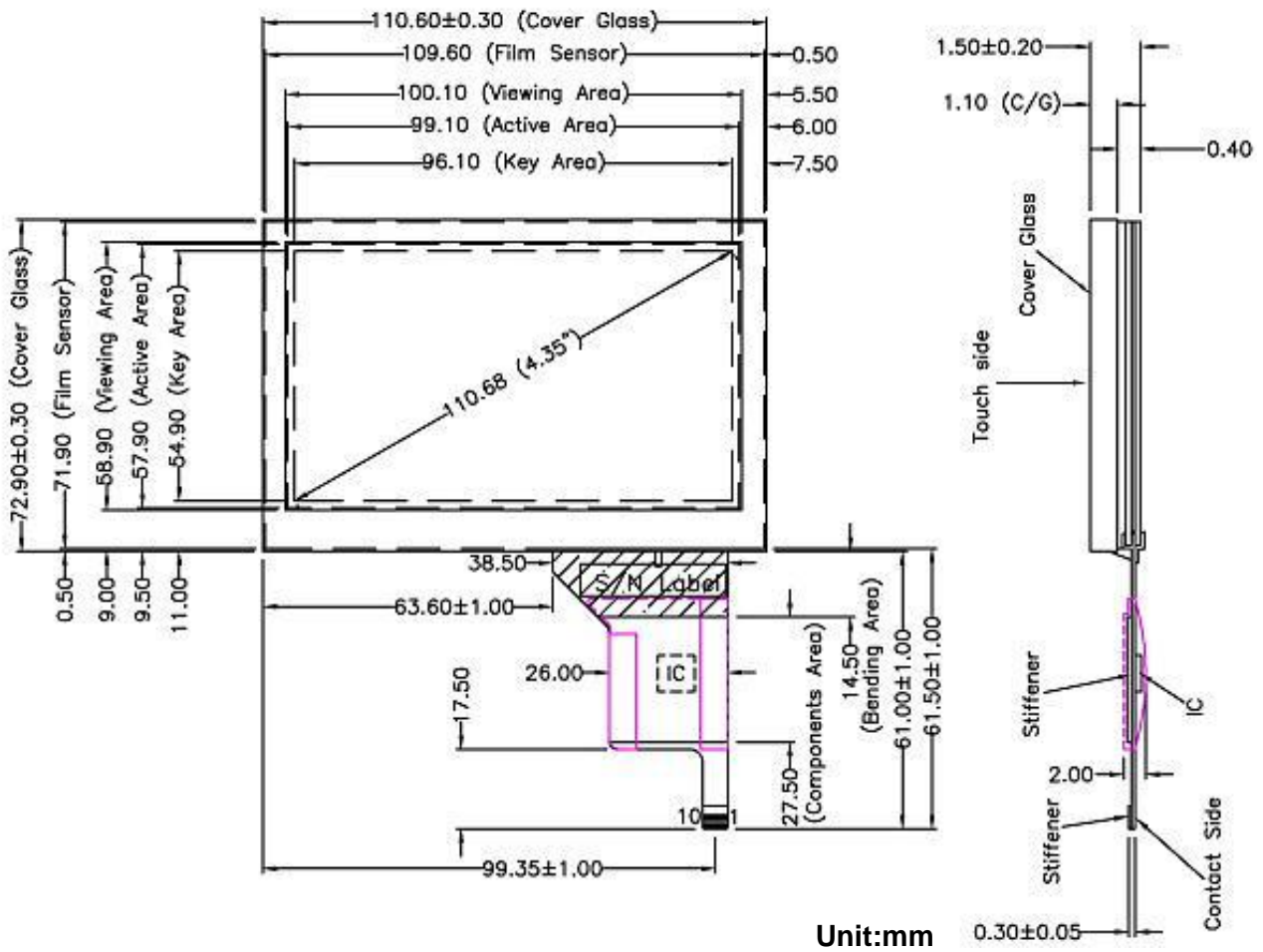

P3015-CG0 : 4.3" PCI with 1.1mm black printed glass

Front View

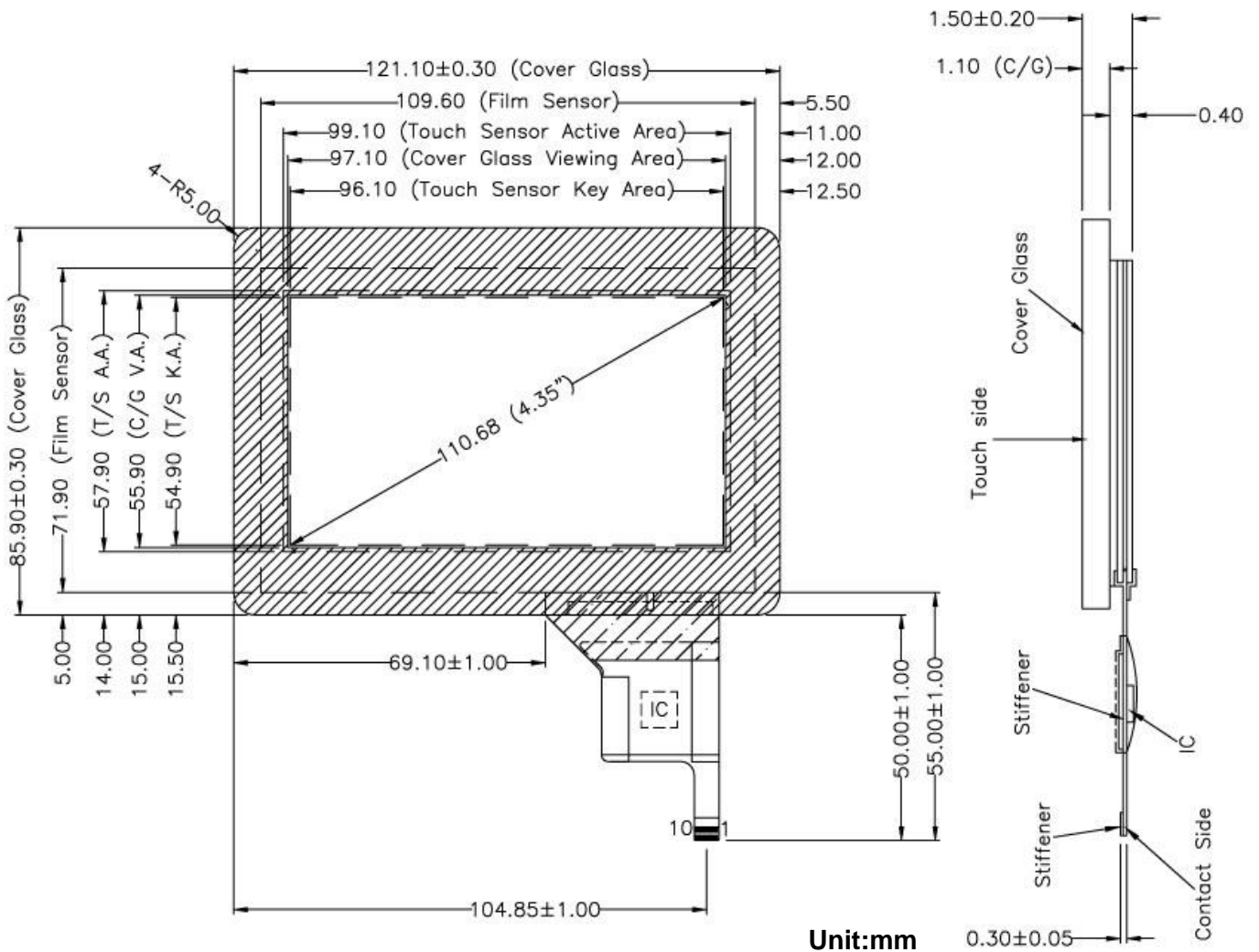

P3015-C10: 4.3" PCI without top glass

Front View

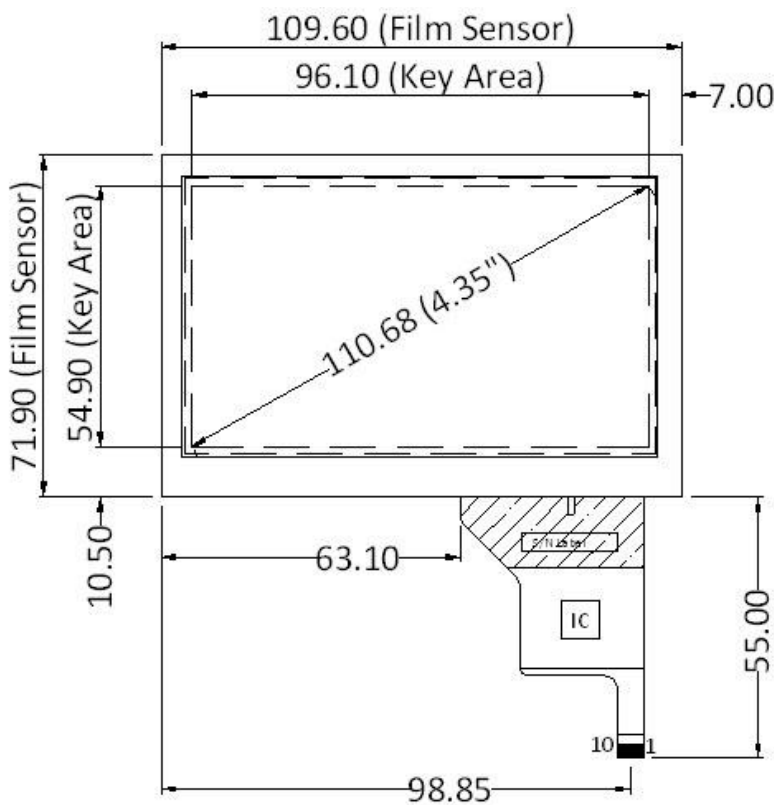
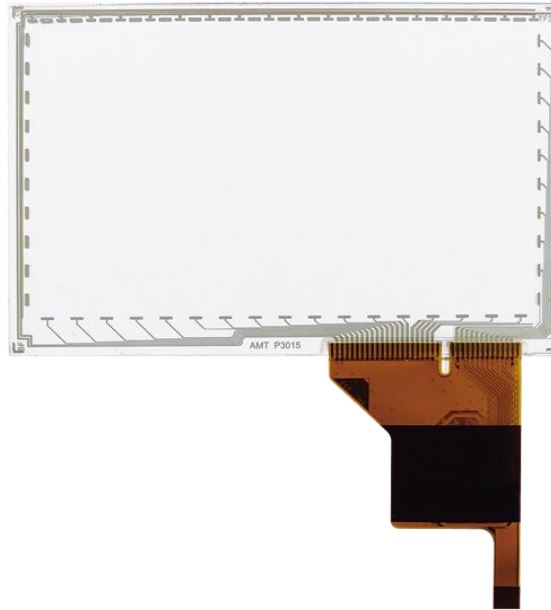

Unit:mm

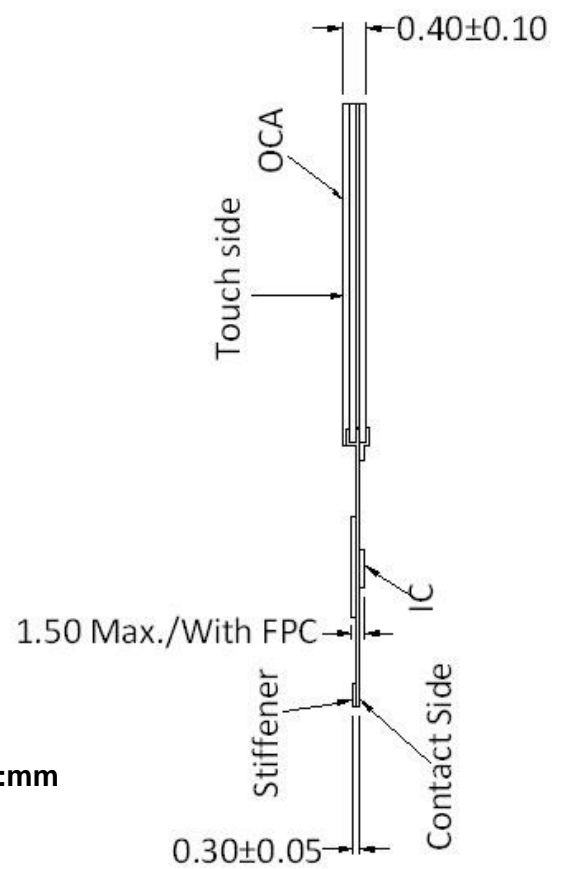

**Remark:** Item P3015-C10 is only available for AMT's selected partners.

P3015-C1A: 4.3" PCI without top glass

Front View

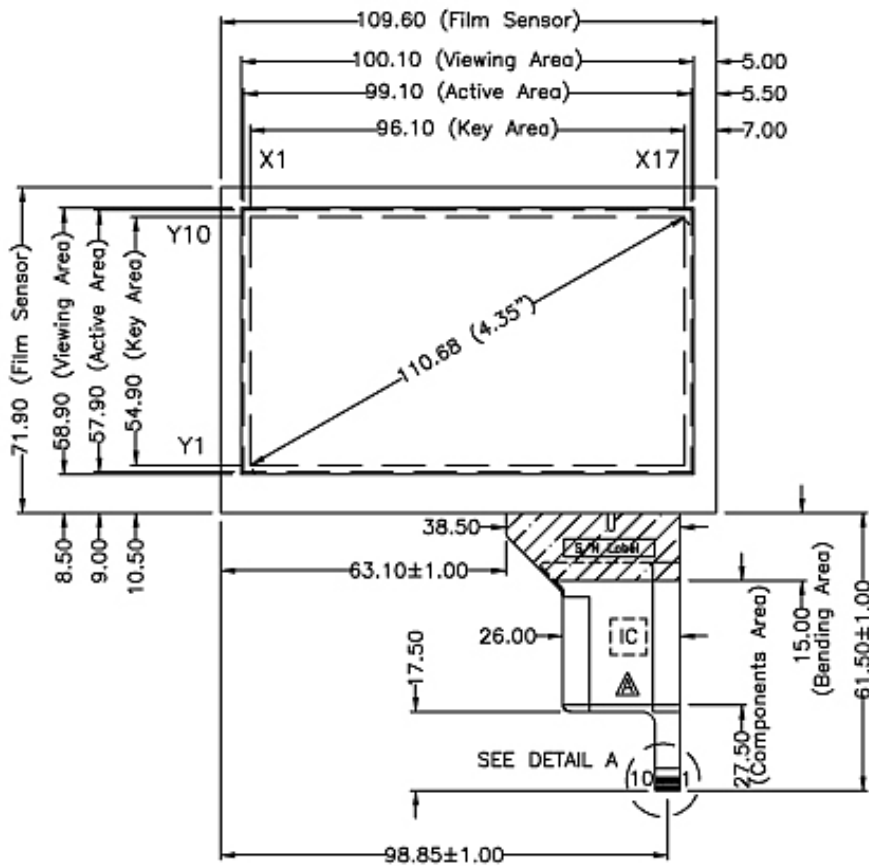

Unit:mm

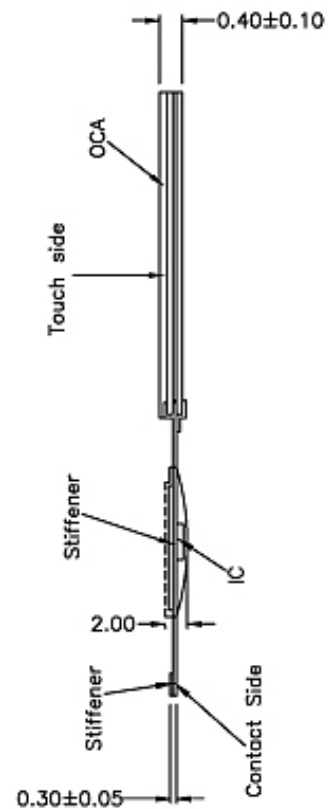

Remark: Item P3015-C1A is only available for AMT's selected partners.

2.2.2 PM2101 COF Tail Mechanical Drawing and Rear/ Front View

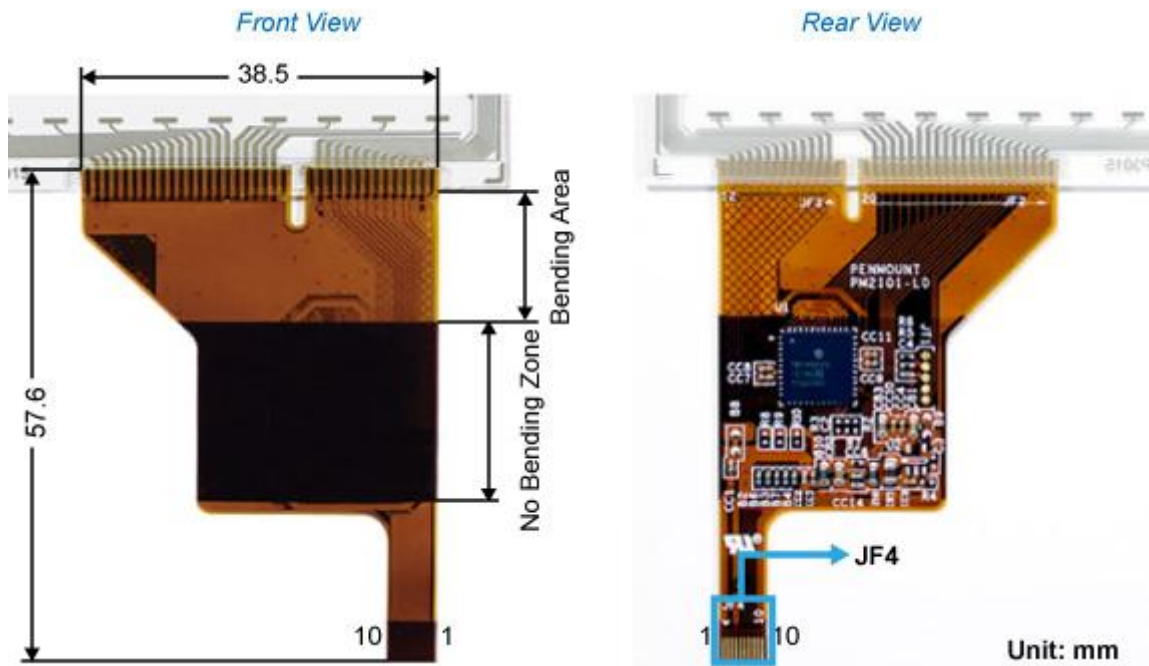

Bending radius: R2.5mm

JF4 / 10PIN / PC, UART	
Pin	Designation
1	VCC (5V)
2	NC
3	NC
4	GND
5	SCL,RXD
6	SDA, TXD
7	NC
8	NC
9	INTHM
10	NC

2.2.3 PM2102 COF Tail Mechanical Drawing and Rear/ Front View

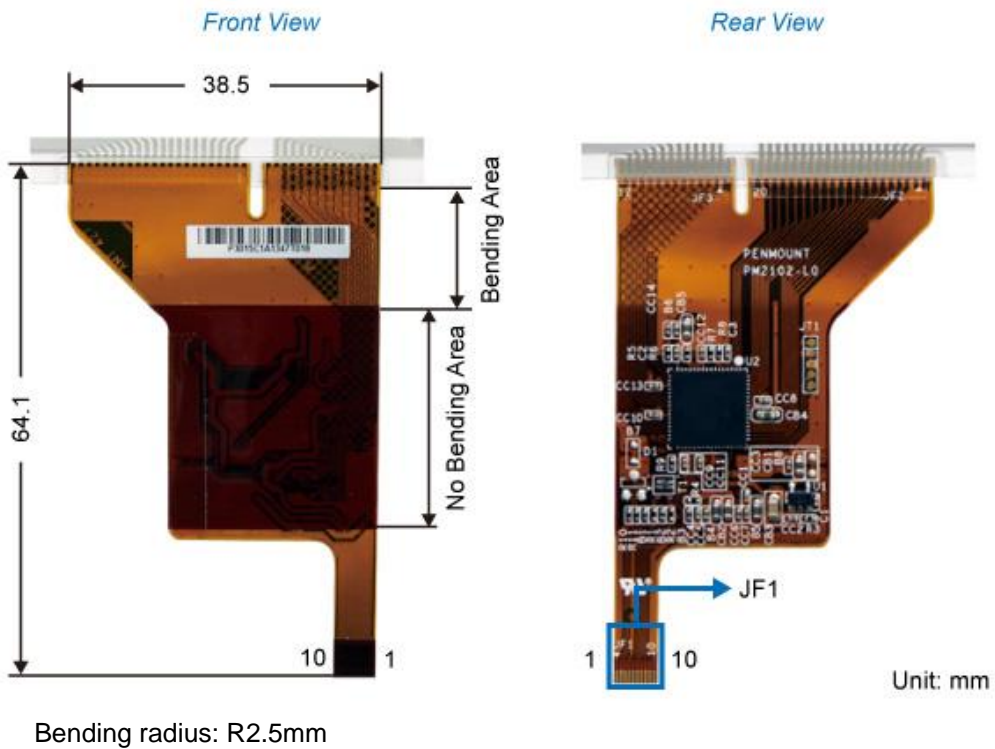

JF1 / 10PIN / I <sup>2</sup> C, USB, UART	
Pin	Designation
1	VCC 5V
2	D-
3	D+
4	GND
5	SCL,RXD
6	SDA, TXD
7	RESET
8	DETECT
9	INTHM
10	VCC 3.3V

Note : If you use I<sup>2</sup>C interface, please add pull-up resistor 2.2K at SCL / SDA / INTHM.

## Chapter 3: PM2101 & PM2102 COF Tail Hardware Specifications

### 3.1 PM2101 Interface Specifications

There are 10 pins on PenMount PM2101 COF tail, the terminator is ZIF type, pitch is 0.5mm, contact side is downward, and contact terminator is with gold plate, the pin definition is set as below:

JF4 / 10PIN / I <sup>2</sup> C, UART			
Pin	Designation	Pin	Designation
1	VCC (5V)	6	SDA, TXD
2	NC	7	NC
3	NC	8	NC
4	GND	9	INTHM
5	SCL, RXD	10	NC

### 3.2 PM2102 Interface Specifications

There are 10 pins on PenMount PM2102 COF tail, the terminator is ZIF type, pitch is 0.5mm, contact side is downward, and contact terminator is with gold plate, the pin definition is set as below:

JF1 / 10PIN / I <sup>2</sup> C, USB, UART			
Pin	Designation	Pin	Designation
1	VCC 5V	6	SDA, TXD
2	D-	7	RESET
3	D+	8	DETECT
4	GND	9	INTHM
5	SCL, RXD	10	VCC 3.3V

### 3.3 COF tail System Block Diagram

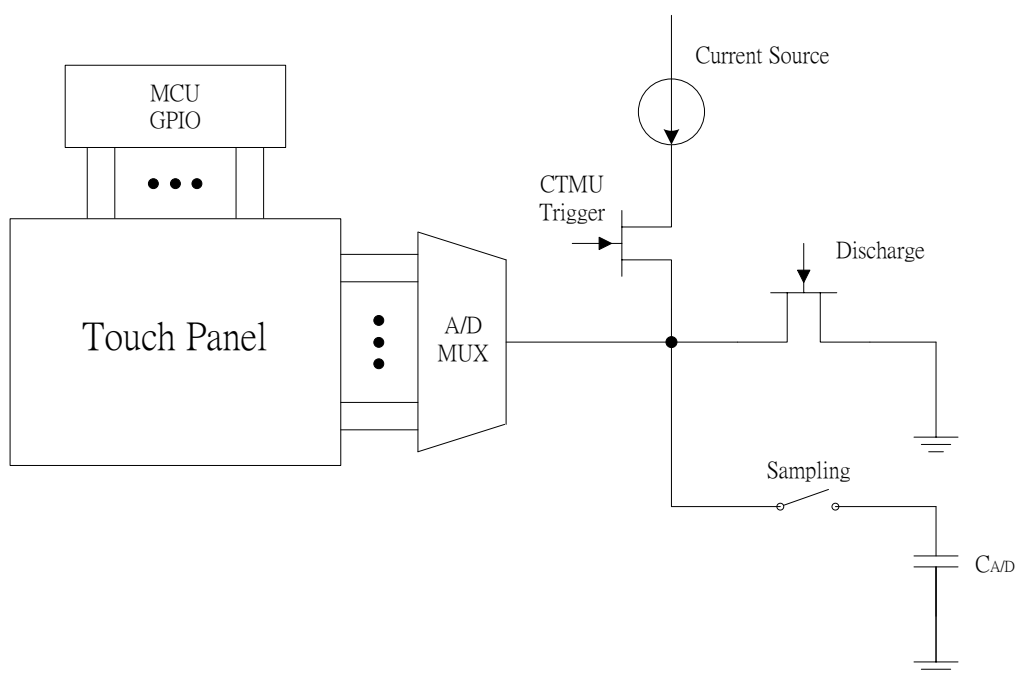



### 3.4 Interface

We provide 10-pin COF tail, you can use different interfaces to connect COF tail to your system. The followings are the functions for different interfaces.

#### 3.4.1 USB Interface and Data Communication

USB (Universal Serial Bus) is an industry standard, which is a connection between the computer/ notebook/ laptop and the external devices. It is commonly used in connecting to PC or handheld device. There are 4 pins on COF tail to define USB connection.

#### 3.4.2 UART Interface and Data Communication

A UART (Universal Asynchronous Receiver/ Transmitter) is a serial port, it is commonly used in conjunction with communication standards such as RS-232 or others. In COF tail design, PenMount only provide UART interface for connecting to the host.

#### 3.4.3 I<sup>2</sup>C

The I<sup>2</sup>C (Inter-IC) bus is a bi-directional two-wire serial bus that provides a communication link between integrated circuits (ICs).

The I<sup>2</sup>C bus has two roles for nodes: master and slave:

- Master node — node that issues the clock and addresses slaves
- Slave node — node that receives the clock line and address.

The bus is a multi-master bus which means any number of master nodes can be present. Additionally, master and slave roles may be changed between messages (after a STOP is sent).

There are four potential modes of operation for a given bus device, although most devices only use a single role and its two modes:

- master transmit — master node is sending data to a slave
- master receive — master node is receiving data from a slave
- slave transmit — slave node is sending data to the master
- slave receive — slave node is receiving data from the master

PenMount I<sup>2</sup>C interface provide 'INTHM' pin as an optional. Generally, I<sup>2</sup>C (without INTHM pin) uses polling communication method, master communicates with slave in a period of time. If there is an INTHM pin, slave can "ask" master whether it gets ready or not, so that master no need to keep "asking" slave, thus it becomes more efficient.

### 3.5 Suggested Connectors on System Side for COF tail terminator

Flip-lock type connectors with bottom contact points or side entry type connectors with bottom contact points or double side contact connectors can be used to connect COF tail, details of the suggested side entry bottom contact connector is shown in no. 1:

1. Manufacturer: AMP model no. 1-1734844-0

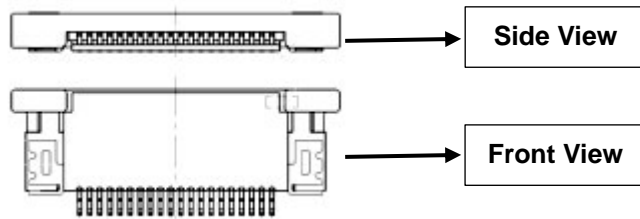

- 0.50 mm pitch
- 10 pins
- Gold contact plating, mating area, material
- Please refer to its detail specification

Please see the suggested flip-lock type connectors with bottom contact points as below:

2. Manufacturer: Hirose model no. FH52-10S-0.5SH
3. Manufacturer: AMP model no. 1-1734242-0

## Chapter 4: PenMount PCI Controller IC Specifications

### 4.1 General Descriptions

Touch Controller IC	<b>PM2101:</b> PenMount P2-02 <b>PM2102:</b> PenMount P2-03
Interface	<b>PM2101:</b> UART / I <sup>2</sup> C <b>PM2102:</b> USB / UART / I <sup>2</sup> C
ADC resolution	10 bits
Operating Voltage	<b>PM2101:</b> +5V <b>PM2102:</b> +3.3V / +5V
Storage Temperature	-40°C ~ +85°C
Operating Temperature	-20°C ~ +70°C
Power Consumption	<b>PM2101:</b> Typical – Working Mode: 8.8 mA / 5V Idle Mode: 4.5 mA / 5V Sleep Mode: 0.2 mA / 5V <b>PM2102:</b> Typical – Working Mode: 28.0 mA / 5V Idle Mode: 15.6 mA / 5V Sleep Mode: 1.3 mA / 5V
Sample rate/second	Single Point 100 sps / Two Point 80 sps
Touch media	Finger, gloved hand (please contact us for details)
Firmware	Develop by PenMount team
Operation force	Light
Top glass thickness supported	1.1 / 1.8 / 2.8mm
Driver supports	All popular O.S., like Microsoft Windows and Win CE and various Linux distribution

Note: Sample rate/second are varied based on different version of panel and firmware.

PenMount P2-02 is using Microchip PIC18F45K22 IC.

PenMount P2-03 is using Microchip PIC24FJ64GB106 IC.

### 4.2 Control IC Features

#### 4.2.1 Features of PenMount P2-02

- Charge Time Measurement Unit(CTMU)
- 16 MIPS operation at 64MHz CPU
- 32KB program memory
- 10-bit, up to 28 channel Analog-to-Digital converter
- Run mode: 1mA/MIPS, 2.0 Typical
- Sleep mode: Current down to 100nA Typical
- Standby Current with 32 KHz Oscillator: 2.5uA, 2.0V typical
- Other details controller specification, please refer to Microchip PIC18F45K22 datasheet

#### 4.2.2 Features of PenMount P2-03

- Charge Time Measurement Unit(CTMU)
- 16 MIPS operation at 32MHz CPU
- 64KB program memory
- 10-bit, up to 16 channel Analog-to-Digital converter
- On-Chip 2.5V Voltage Regulator
- Run mode: 1mA/MIPS, 2.0 Typical
- Sleep mode: Current down to 100nA Typical
- Standby Current with 32 KHz Oscillator: 2.5uA, 2.0V typical
- USB, UART, I<sup>2</sup>C serial bus
- Other details controller specification, please refer to Microchip PIC24FJ64GB106 datasheet

4.3 Controller IC Pin out

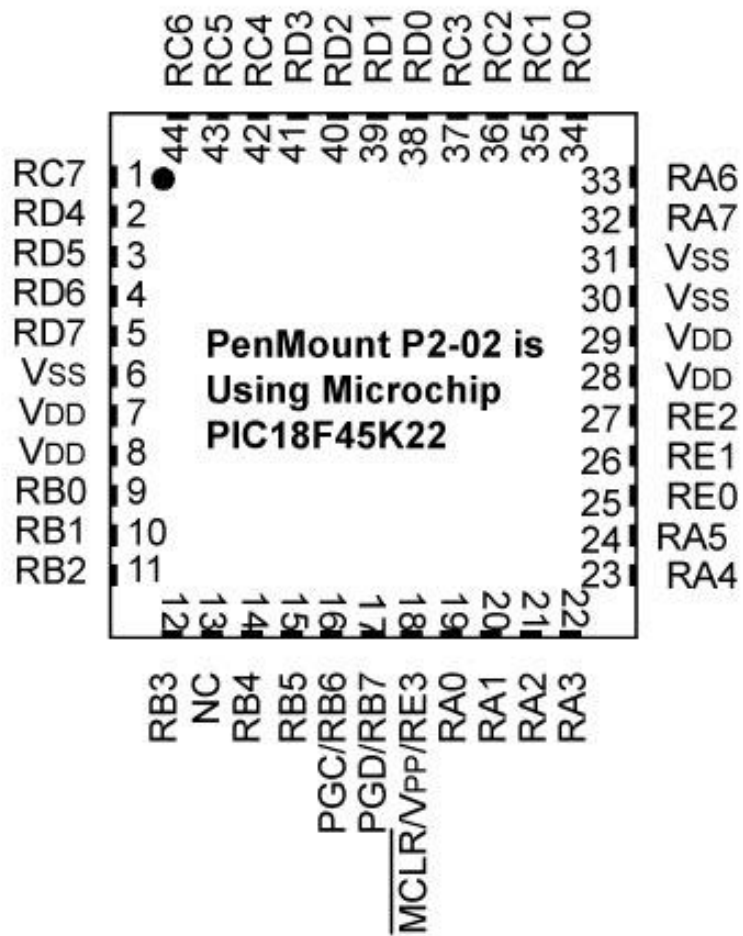

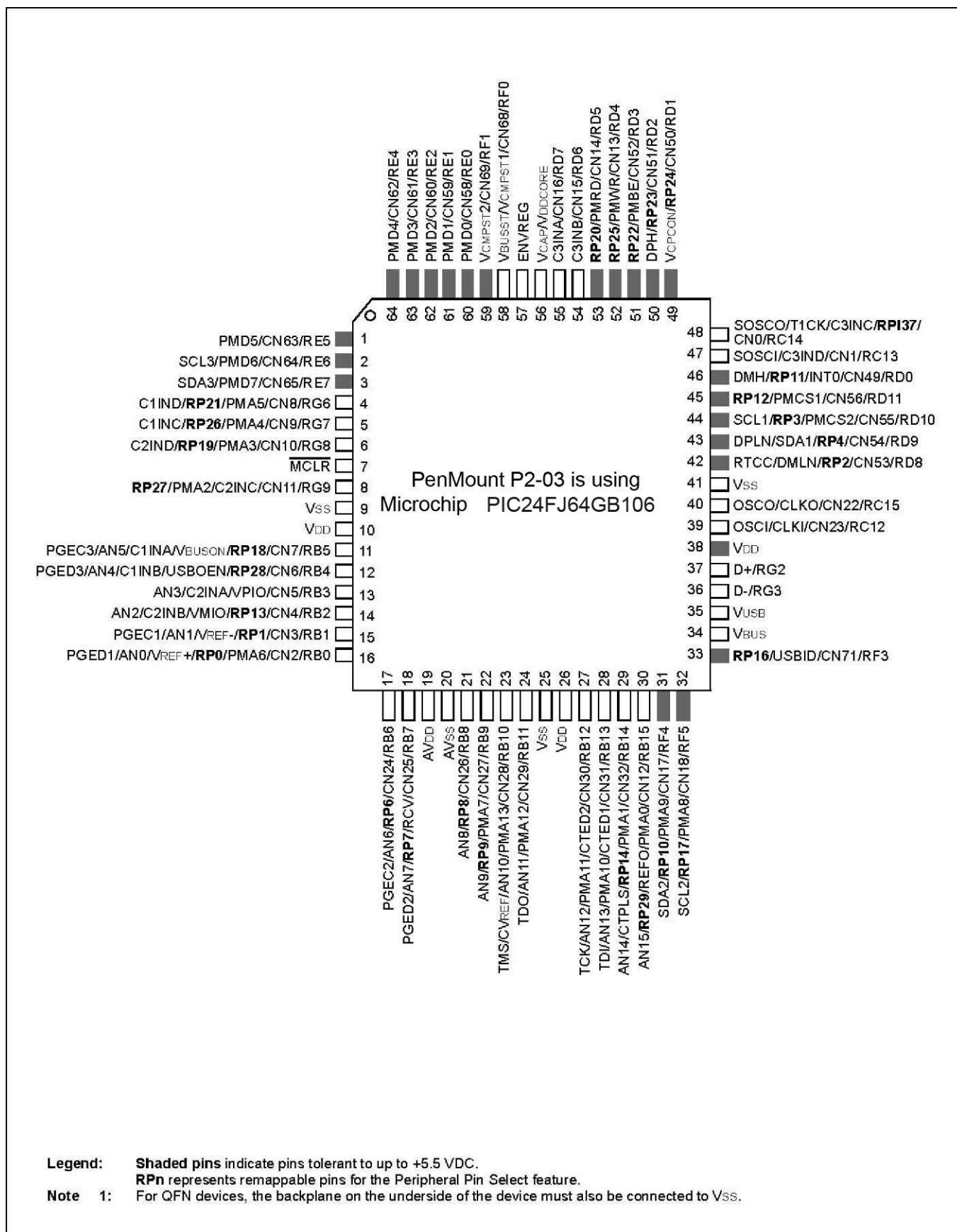

## Chapter 5: Software Drivers & PenMount Utility

### 5.1 Available Drivers & Where to Download

Driver for USB and UART is available in AMT's website, please go to the link below for downloading the drivers you need. However, drivers for I<sup>2</sup>C are not released in our website, if you are using I<sup>2</sup>C, please contact our sale representatives or distributors in your region for further information.

<http://www.amtouch.com.tw/support-downloads/penmount-drivers-and-utilities/pci-touch-controller/>

Please note that if you use USB interface and Windows Vista/7/8, the default driver is available inside the OS, so you no need to download and install an additional driver. The drivers will be modified and updated from time to time, the most updated drivers are available in AMT and PenMount website. Drivers' versions are subject to change without notice.

#### **PM2101:**

For I<sup>2</sup>C

Windows CE : Provide binary driver for freescale iMX platform. Other platform by request.

Linux / Android : Provide source code for integration.

For UART

Windows 2000, XP, 2003: single touch, mouse driver.

Windows Vista: single touch, inbox driver.

Windows 7,8: dual touch, Inbox driver.

Linux: Ubuntu, Android, other Linux distributions under development.

#### **PM2102**

For I<sup>2</sup>C

Windows CE : Provide binary driver for freescale iMX platform. Other platform by request.

Linux / Android : Provide source code for integration.

For USB , UART

Windows 2000, XP, 2003: single touch, mouse driver.

Windows Vista: single touch, inbox driver.

Windows 7,8: dual touch, Inbox driver.

Linux: Ubuntu, Android, other Linux distributions under development.

### 5.2 PCIMSet Introduction

PCIMSet is a utility software developed by PenMount for users to adjust the touch screen's accuracy, sensitivity... and others features. When you have AMT PCI touch kits, we provide you this utility program, so you can choose the appropriate interface through PCIMSet setting. If you need more detailed information, please see "PCIMSet User Guide".

### 5.3 Firmware Update

#### 5.3.1 Firmware Interface

We provide different interfaces in firmware, if the shipping default interface is not required by your system, please contact our sale representatives or distributors in your region for further information on changing interface. There will be new firmware to be updated, details are all described in our "PMUpdate User Guide", please read it carefully before making the firmware update.

#### 5.3.2 New Firmware Request

The latest PenMount controller firmware version is programmed inside the chip. PenMount controller firmware is able to be renewed in customer side, PenMount will release the new firmware with new features or modification, the new updated firmware is available in AMT or PenMount customer services team. As the new updated firmware is sent by request, if you need to update the new firmware, please follow the updated firmware request procedures as below:

- a. First, please fill in the 'PenMount PCI Firmware Update Request' (FUR) form. The FUR form is sent by request, so please contact our sale representatives, customer services team or distributors in your region for requesting the FUR form.
- b. Sent back the FUR form to AMT or PenMount sale representatives, customer services team or distributors in your region.
- c. After checking and confirmed by AMT or PenMount team, we will send the updated firmware for customers to do on field update.

#### 5.3.3 Firmware download and update

The PMUpdate utility is developed for users to update the latest firmware version. Please note that only our standard firmware offers a free update service, if it is a special developed firmware in accordance with the requests of the client, or any adjustment has been made for the firmware due to the requests of the client, these are regarded as a special firmware, and they won't have a free firmware update. The firmware update will be provided once we have a new firmware ready. If you need any further information about this, please contact our sale representatives or distributors in your region. And if you want to get more information about the operation steps of PMUpdate, you can read "PMUpdate User Guide" to get more details.

## Chapter 6: Product Test

The following test has been done by AMT Projected Capacitive Touch and PenMount controller or Control board.

### 6.1 Operating Test

PCI Touch panels were tested under the temperatures range at -20°C and +70°C, the PCI touch panels can operate normally under the above temperature.

### 6.2 Environmental Test

PCI touch panels were tested under the temperature:

- -40°C for 288H,
- 60 °C with 90RH for 288H,
- 80°C for 288H,
- -40°C ~ +80°C for 20 cycles.

Touch panels can operate normally after the test, please see the PCI approval sheet for details.

### 6.3 ESD

PCI touch solution can withstand 15KV air discharge and 8KV contact discharge. However, the PCI touch has to be integrated properly with good grounding.

### 6.4 Linearity Test

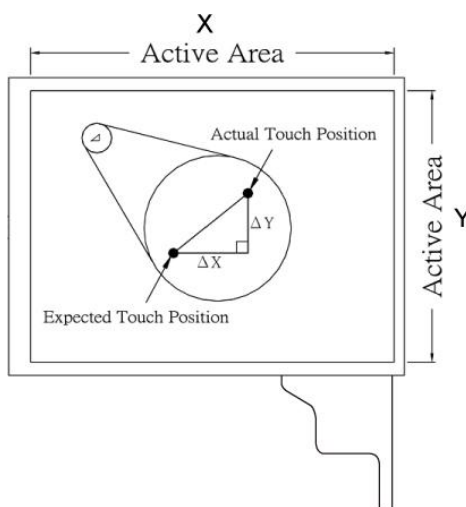

This test is to calculate the difference between the actual touch position and the expected touch position, which

$$\frac{\Delta X}{X} \% < 2.5\% \quad \text{and} \quad \frac{\Delta Y}{Y} \% < 2.5\%$$

### 6.5 Optical Inspection

AMT PCI has its optical specification, please refer to AMT PCI optical specification A003-1 and A003-2.

### 6.6 Others

For other test, please contact to our sale representatives or distributors for detailed information.



### Chapter 7: Warranty

We provide one year limited liability warranty. We shall not be held responsible for any damage, destroy or defect caused by accident, misinstallation, misunderstanding of the instructions, customer modification, misuse of software or their use in a defective or deficient environment or any misuse during their operation of the touch panels.

Note:

When there is water on the surface of the PCI touch panel, please wipe it dry. Then the PCI will function properly.

### Chapter 8: Other Documents

The following documents can be provided to our clients for guiding our customers how to install and operate our products:

- AMT PCI Integration Guide—AMT PCI Integration guide is the guide that to instruct you how to install the touch panel into your products, and what you should aware of.
- AMT PCI Design Guide—AMT PCI Design Guide describes the general design rules and requirements for AMT projective capacitive input (PCI) touch panels, such as their structure, size, pattern and lines.
- PCI PenMount 1000 Device Driver Development Guide—it provides necessary information about the protocols for PenMount and guide you to operate the UART and I<sup>2</sup>C protocols of PenMount 1000.
- PenMount Projected Capacitive Input (PCI) User Guide—PenMount Projected Capacitive Input (PCI) User Guide contains detailed information of our touch panels, such as what software you need, how to install drivers, what is PenMount PCIMSet and firmware update instructions and etc. You can go to the link below to download the manual/ PenMount Projected Capacitive Input (PCI) User Guide.

<http://www.amtouch.com.tw/support-downloads/manuals-downloads/>

Note: AMT PCI Integration Guide, AMT PCI Design Guide and PCI PenMount 1000 Device Driver Development Guide are sent by request, so please feel free to contact our sale representatives or distributors in your region for request if you need these guides. Document versions are subject to change without notice.

### Chapter 9: Contact Information

#### Headquarter

#### Apex Material Technology Corp.

No. 84, WuXun Street, Anle District,  
Keelung City 20446, Taiwan R.O.C.

Tel : + 886-2-2430 2666

Fox: + 886-2-2430 3255

Email: [amt1@amtouch.com.tw](mailto:amt1@amtouch.com.tw)

Web : [www.amtouch.com.tw](http://www.amtouch.com.tw)

#### The North American Sales Office

#### AMTouch USA, Inc.

5050 W. State Street  
Milwaukee, WI 53201, USA

Tel : + 1-414-847-1814/15

Fax : + 1-414-445-1968

Website: [www.amtouchusa.com](http://www.amtouchusa.com)

Email: [sales@amtouchusa.com](mailto:sales@amtouchusa.com)