

Oslon4 PowerStar Whites

ILH-ON04-xxxx-SC201-xx Series

Product Overview

At the heart of each PowerStar are 4 Osram Opto Semiconductors Oslon SSL LED giving outstanding brightness and luminance. PowerStars are compact powerful LED light sources built on aluminum substrates for optimal thermal management. Available with and without connecting wires.

Applications

- General Lighting
- Decorative Lighting
- Task Lighting
- Spot Lighting
- Downlighters
- Retail and Entertainment Lighting

Technical Features:

- Oslon4 PowerStars contain 4 Osram Oslon SSL LEDs with integral silicon resin lens
- Up to 100,000 Hour lifetime to 70% of original brightness
- Mounting holes using M3 screws allows easy installation
- Size (L x W x H) : 20mm x 20mm x 3.85mm
- Available with or without 200mm connecting wires
- Operation with Osram Optotronic® power supplies, or any other constant current power supply
- PowerStars can be linked together to produce longer chains.
- Current range 100 to 1,000mA

*This datasheet should be read in conjunction with the relevant Osram Opto Semiconductors data on the LED used

Important Information and Precautions

- The PowerStar LEDs, when powered up, is very bright thus it is advised that you do NOT look directly at it. Turn the PowerStar away from you and do not shine into the eyes of others.
- PowerStars will overheat in operation if not attached to a suitable heat-sink. Over heating can cause failure or irreparable damage.
- Do not operate PowerStars with power supplies with unlimited current. Connection to constant voltage power supplies that are not current limited may cause the PowerStar to consume current above the specified maximum and cause failure or irreparable damage.
- PowerStars, when operated, can reach high temperatures thus there is risk of injury if they are touched.

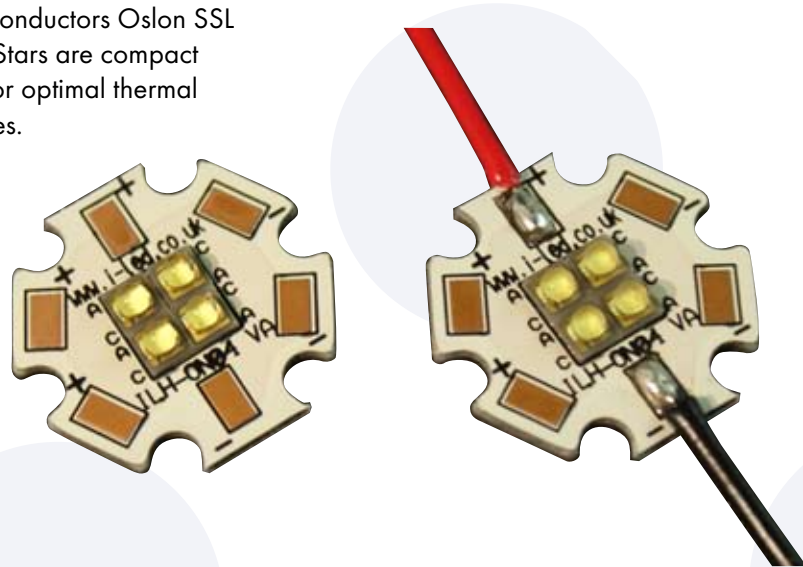

Product Options

ILS PART NUMBER	Colour	Colour Temp* (Degrees Kelvin)	TypicalWattage §		Forward Voltage	Flux † at 350mA	Radiance Angle	Relevant Osram LED Data
			at 350mA	at 700mA				
ILH-ON04-ULWH-SC201	Cool White	6000K to 6500K	4.48 watts	8.96 watts	11.00 to 15.00 volts	< 484 lms	80° (± 40°)	LUW CP7P
ILH-ON04-NUWH-SC201	Neutral White	4000K	4.48 watts	8.96 watts	11.00 to 15.00 volts	< 416 lms	80° (± 40°)	LCW CP7P
ILH-ON04-WMWH-SC201	Warm White	3000K	4.48 watts	8.96 watts	11.00 to 15.00 volts	< 388 lms	80° (± 40°)	LCW CP7P

* Due to the special conditions of the manufacturing processes of LED the typical data of technical parameters can only reflect statistical figures and do not necessarily correspond to the actual parameters of each single product which could differ from the typical data.

§ Tolerance +/- 10%

† Measured with 20ms 350mA pulse at 25° c

Part Number Ordering Information for Oslon4 PowerStars With and Without Wires

Colour / CCT Ref	Part Number no wires	Part Number with 200mm wires
Cool White 6000K-6500K	ILH-ON04-ULWH-SC201	ILH-ON04-ULWH-SC201-WIR200.
Neutral White 4000K	ILH-ON04-NUWH-SC201	ILH-ON04-NUWH-SC201-WIR200.
Warm White 3000K	ILH-ON04-WMWH-SC201	ILH-ON04-WMWH-SC201-WIR200.

Minimum and Maximum Ratings

ILS PART NUMBER	Operating Temperature at Tc-Point [°C]*	Storage Temperature [°C]*	Forward Current per chip [mA]*	Reverse Voltage [Vdc]*
ILH-ON04-ULWH-SC201	70° C max	- 40 to 110° C	1,000mA max	not designed for reverse voltage
ILH-ON04-NUWH-SC201	70° C max	- 40 to 110° C	1,000mA max	not designed for reverse voltage
ILH-ON04-WMWH-SC201	70° C max	- 40 to 110° C	1,000mA max	not designed for reverse voltage

* Exceeding maximum ratings for operating and storage temperature will reduce expected life time or destroy the LED module.

Exceeding maximum ratings for operating voltage will cause hazardous overload and will likely destroy the LED module.

The temperature of the LED module must be measured at the Tc-Point according to EN60598-1 in a thermally constant status with a temperature sensor or a temperature sensitive label.

Radiation of single LED

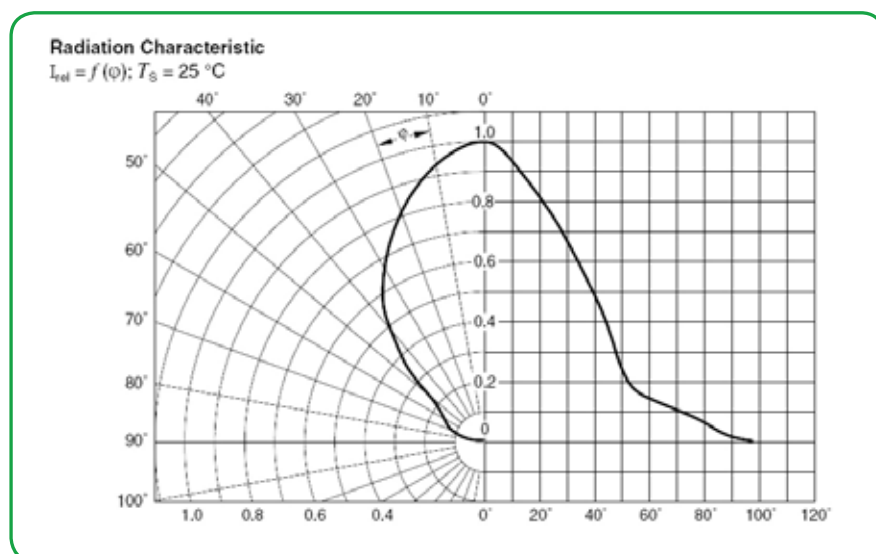

Technical Drawing without cables (mm)

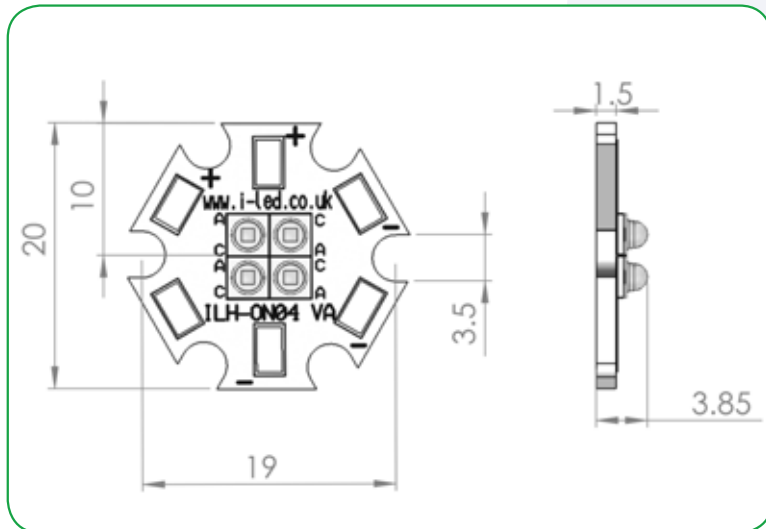

3D drawing files are available on request from iLS. Please call or email

Technical Drawing with cables (mm)

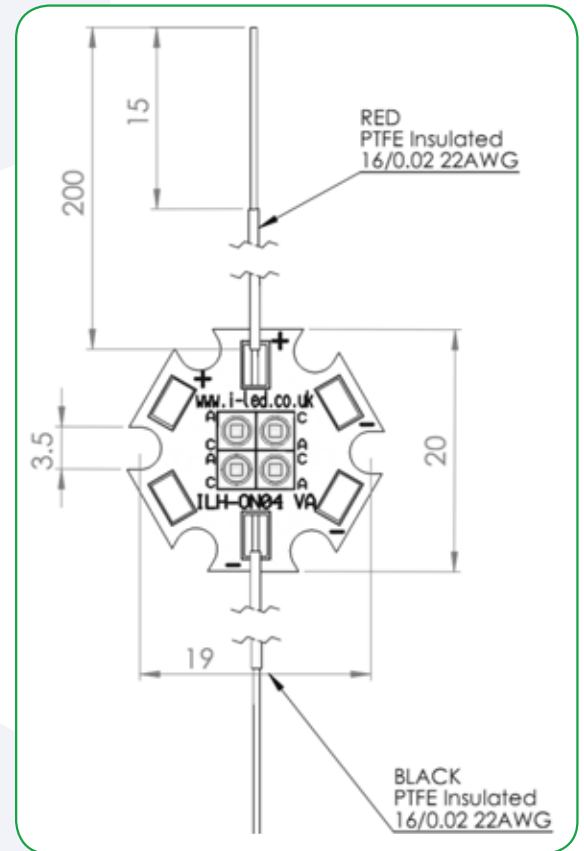

Oslon4 PowerStar Lens and Reflector Options

Currently there are no options for Lens or Reflectors for the Oslon 4 family.

Assembly Information

- The mounting of the Oslon4 PowerStars has to be on a metal heat sink.
- In order to optimise the thermal management the metal surface needs to be clean (dirt and oil free) and planar for the best contact with the LED module. A thermal grease or heat transfer material is highly recommended

Safety Information

- The LED module itself and all its components must not be mechanically stressed.
- Assembly must not damage or destroy conducting paths on the circuit board.
- The mounting of the module is carried out by attaching it at the mounting holes. Metal mounting screws must be insulated with synthetic washers to prevent circuit board damage and possible short circuiting.
- To avoid mechanical damage to the connecting cables, the boards should be attached securely to the intended substrate. Heavy vibration should be avoided.
- Observe correct polarity!
- Depending on the product incorrect polarity will lead to emission of red or no light. The module can be destroyed!
- Pay attention to standard ESD precautions when installing the Oslon4 PowerStars.
- The Oslon4 PowerStars, as manufactured, has no conformal coating and therefore offers no inherent protection against corrosion.
- Damage by corrosion will not be accepted as a materials defect claim. It is the user's responsibility to provide suitable protection against corrosive agents such as moisture and condensation and other harmful elements.
- For outdoor usage, a housing is definitely required to protect the board against environmental influences. The design of the housing must correspond to the IP standards in the application. It is also the responsibility of the user to ensure any housings or modifications keep the Tc junction temperature to within stated ranges.
- To also ease the luminaire/installation approval, electronic control gear for LED or LED modules should carry the CE mark and be ENEC certified. In Europe the declarations of conformity must include the following standards: CE: EC 61374-2-13, EN 55015, IEC 61547 and IEC 61000-3-2 - ENEC: 61374-2-13 and IEC/EN 62384.

For further information please contact ILS.

The values contained in this data sheet can change due to technical innovations. Any such changes will be made without separate notification.