

# CL-L330-C26N-C-02

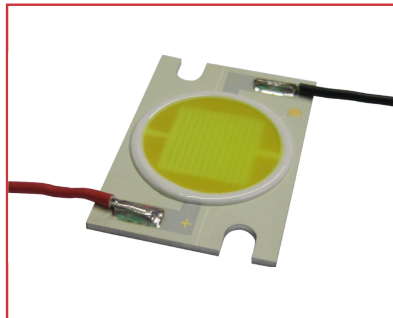

## features



- 26W white high power LED
- 120° viewing angle
- Colour temperature 5,000K
- 150mm flying leads as standard, custom lengths available on request

## specifications

### absolute maximum ratings

parameter	symbol	rating value	unit
power dissipation	Pd	35.8	W
forward current	I <sub>F</sub>	840	mA
forward pulse current	I <sub>FP</sub>	1,200	mA
reverse current	I <sub>R</sub>	1	mA
operating temperature	T <sub>OP</sub>	-30 ~ +85	°C
storage temperature	T <sub>ST</sub>	-40 ~ +100	°C
junction temperature	T <sub>j</sub>	120	°C

### electro-optical characteristics

parameter	symbol	condition	min.	typ.	max.	unit
forward voltage	V <sub>F</sub>	I <sub>F</sub> =720mA	34.8	37.2	42.0	V
thermal resistance	R <sub>j-c</sub>	junction-case	-	1.7	-	°C/W
luminous flux	Ø <sub>v</sub>	I <sub>F</sub> =720mA	2380	2800	-	lm
high general colour	Ra	I <sub>F</sub> =720mA	-	67	-	-

## to order

to order please contact us on: t: **+44 (0)1229 582 430** f: **+44 (0)1229 580 012**  
e: **sales@marl.co.uk** w: **www.optosource.com**

© marl international limited technical documentation has been designed by marl international limited for the intention of providing information, which must not be copied or released to a third party without prior written consent from marl international limited. the information provided does not constitute part of any order or contract and should not be regarded as a representation relating to either products or service. no responsibility can be assumed for inaccuracies or printing errors. marl international limited reserve the right to alter without notice the specification or any conditions of supply for product or service



BS EN ISO 9001:2008  
approved manufacturer



# CL-L330-C26N-C-02



## technical data

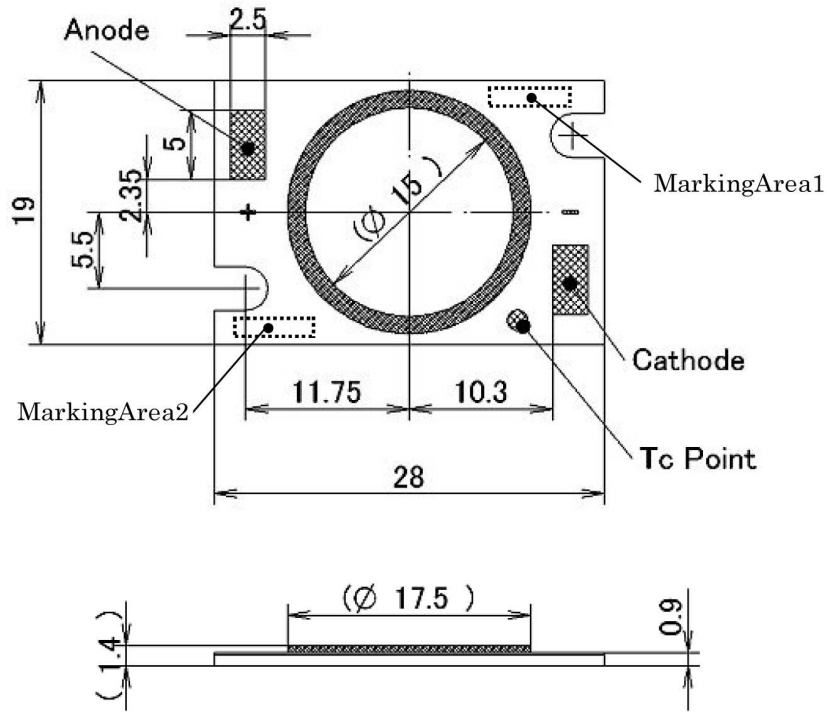

Please note this product comes complete with 150mm flying leads (not shown in diagram). Longer lengths are available on request.

## precautions

1. Avoid the application of any stress to the lens portion
2. Avoid any contact by a sharp metal nail or other materials with the lens portion
3. This product should be secured firmly by fastening an M3 screw on both sides of the product. Be careful not to apply any stress to the product during the clamping operation as the connection status could vary depending on materials of outer heat sink please check thoroughly
4. A heat radiating grease should be applied to the whole rear surface so that this product can dissipate heat as a whole. this product could be bent during the clamping operation if heat grease in sheet form is used, thus we recommend the use of heat grease in paste form
5. Please take measures to prevent any static electricity being produced such as the wearing of a wristband or anti static gloves when handling this product

## to order

to order please contact us on: t: +44 (0)1229 582 430 f: +44 (0)1229 580 012  
e: [sales@marl.co.uk](mailto:sales@marl.co.uk) w: [www.optosource.com](http://www.optosource.com)

© marl international limited technical documentation has been designed by marl international limited for the intention of providing information, which must not be copied or released to a third party without prior written consent from marl international limited. the information provided does not constitute part of any order or contract and should not be regarded as a representation relating to either products or service. no responsibility can be assumed for inaccuracies or printing errors. marl international limited reserve the right to alter without notice the specification or any conditions of supply for product or service

