



Laserlyte-Flex Userguide

1. Product Overview

Thank you for purchasing the Laserlyte-Flex Alignment System. This module emits a spot or pattern in the visible wavelength range.

If you have any queries or require help when using the Laserlyte-Flex please call us on +44(0)1495 212213 or contact your local representative.

The Laserlyte-Flex alignment system is a unique, interchangeable, low cost plug and play laser system that was designed specifically for aligning and positioning of garments, cloth, paper, wood and metal. The system has a range of interchangeable projections which convert the base dot laser into a line or cross. A range of intensities are available in order to maximise the visual appearance of the projection even against the darkest materials. The Laserlyte-Flex has a user adjustable focus making it easy to focus over a wide range of distances. Complete with mounting brackets, electrical leads and power supply the system is ready to use with no previous laser experience required.



2. Production Operation

2A Operating with a PS1 or PS4

If you have purchased a Laserlyte-Flex with a 100V/240V to 3.5Volt PS1 or PS4 you will have the following items:-

Laserlyte-Flex Laser

Extension Lead (Optional)

100V/240V to 3.5Volt PS1 or PS4

Main socket to PS1/PS4 power lead (UK, Euro or US)

1. If you have purchased an extension lead plug the male DC Jack end of the extension lead into the DC socket on the PS1/PS4, then plug the male DC Jack on the Laserlyte-Flex laser cable into the DC socket on the extension lead. If you have a Laserlyte-Flex laser simply plug the male DC Jack into the DC socket on the PS1/PS4. If you are using more than one laser with the PS4 repeat the above steps until all the laser are connected to the PS4.
2. Connect IEC plug to PS-1/PS4 power adaptor.
3. Plug the main plug into a mains socket.
4. Switch on the power supply via key switch (If you have purchased a 3.5V PS1/PS4 fitted with a Key switch) or switch on at the mains socket.

2B Operating with a 11/24 Vdc Adaptor

If you have purchased a Laserlyte-Flex with a 12/24 Volt DC Adaptor you will have the following items:-

Laserlyte-Flex Laser

Extension Lead (Optional)

12/24 Volt DC Adaptor

1. If you have purchased an extension lead plug the male DC Jack end of the extension lead into the DC socket on the 12/24 Volt DC Adaptor, then plug the male DC Jack on the Laserlyte-Flex laser cable into the DC socket on the extension lead. If you have a Laserlyte-Flex laser simply plug the male DC Jack into the DC socket on the 12/24 Volt DC Adaptor.
2. To the flying leads on the power adaptor connect as follows:
Red: +11 Vdc to +32 Vdc
Black: 0 Vdc
Yellow: Chassis Earth
- 3: Switch on the DC supply to the 12/24 Volt DC Adaptor.

3. Focus Adjustment

The focus of the laser can be adjusted by using the supplied focus key. Should you need to adjust the focus please follow the instructions below:

1. Remove any interchangeable pattern optics, where fitted.
2. Insert focus key into laser barrel and align with focus control grooves.
3. Turn the focus key until desired focus is achieved.
4. Replace the interchangeable pattern optics if fitted and rotate to achieve the desired projection.

4. Changing Optics

A number of user adjustable interchangeable patterns optics are available as extra items for the Laserlyte Flex which allow the base laser module to project a range of patterns such as Cross, lines and line + centre dot, to change the pattern please follow the instructions below:

1. Remove any interchangeable pattern optics if fitted (see drawing A).
2. Replace the interchangeable pattern optics and rotate to achieve the desired projection.
3. Please ensure that any optics not fitted to the laser module is keep away from sources of dust etc.

5. Mounting

To ensure the lifetime and the stability of the laser it is recommended that it is mounted in a suitable Heat sink/mount. The case temperature should be kept within the specified range at all times failure to do this could result in shortened lifetime or catastrophic failure. As a guide, laser diode lifetime decreases by a factor of two (approx) for every ten degree increase in operating temperature.

There are two mounting clamps available as stranded from Global Laser for the Laserlyte-Flex range.

Global Laser's MK1 mounting kit provides a cost effect mounting solution; the laser clamp rotates horizontally through 360 degrees and vertically through 180 degrees and the mounting post allows vertical movement. The mounting clamp is compatible with Global Laser mounting brackets.

Global Laser's Heavy Duty Clamp has parallel and vertical adjustment which allows the user to aim the laser in any required direction or angle, the robust aluminium construction also assists in conducting heat away from the laser body as well as prevents movement due to shock and vibration. The base plate of the Heavy Duty Clamp has a series of threaded holes to allow the Heavy Duty Clamp to be securely fastened to stable surface. An Magnetic base is also available which simply screws in to the base of the Heavy Duty Clamp and allow it to be fitted to a ferrous surface.

5A Mounting the Laserlyte-Flex in the Heavy Duty Clamp

1. Un-tighten Allen screw A (see drawing B) with the supplied Allen screw.
2. Slide the laser into the mounting hole (see drawing D) and tighten Allen screw A.
3. For vertical adjustment of the laser un-tighten Grub screw A (see drawing D). This will allow the section mounting the laser to be adjusted. When the vertical posting is complete re-tighten grub screw A.
4. For horizontal adjustment of the laser un-tighten Grub screw B (see drawing B). This will allow the main body of the mount to be moved. When the horizontal positing is complete re-tighten grub screw B.
5. To secure the Heavy Duty Clamp to a surface machine screw or studs can be used in conjunction with the base section (see drawing B for thread details).

5B Mounting the Laserlyte-Flex in the Heavy Duty Clamp with the Magnetic Base

1. Un-tighten Allen screw A (see drawing B) with the supplied Allen key.
2. Slide the laser into the mounting hole (see drawing B) and tighten Allen key A.
3. For vertical adjustment of the laser un-tighten Grub screw A (see drawing B). This will allow the section mounting the laser to be adjusted. When the vertical posting is complete re-tighten grub screw A.
4. For horizontal adjustment of the laser un-tighten Grub screw B (see drawing D). This will allow the main body of the mount to be moved. When the horizontal positing is complete re-tighten grub screw B.
5. To secure the magnetic base to the Heavy Duty Clamp simple screw the stud on the top of the magnetic base into the centre hole in the base of the Heavy Duty Clamp until tight.
6. Remove the keeper from the magnetic base and place on a ferrous surface to secure.

5C Mounting the Laserlyte-Flex in the MK1 Mounting Kit

1. Fix the mounting clamp to the mounting surface or bracket and set the height of the mounting post using machine screw A (see drawing C). Tighten with an Allen key to lock into position.
2. Un-tighten Phillips screw A (see drawing C) with a Phillips head screwdriver.
3. Slide the laser into the mounting hole (see drawing C) and rotate the mounting clamp to the desired position and tighten Phillips screw A to lock into position.

6. Working Distances

The size of the fan angle (or spread of the beam) will determine how long the line is. When viewed from the same distance and at 90 degrees to the surface a line with a fan angle of 60 degrees will be longer than a line with a fan angle of 30 degrees. The Laserlyte-Flex can be fitted as standard with line optics with a fan angle of 60 & 90 degrees, Cross optics with a fan angle of 8 degrees and 60 degrees and a line+dot optic with a fan angle of 100 degrees.

Fan Angle (Degrees)	Distance to Object (mm)	Line Length (mm)
30	100	54
60	100	115

As a guide to relationship between working distance, line length and fan angle please see the table below.

		Fan Angle (Degrees)		
		8	60	90
Distance From Object (mm)	250	35	289	500
	500	70	577	1000
	750	105	866	1500
	1000	140	1155	2000
	1250	175	1443	2500
	1500	210	1732	3000
	1750	245	2021	3500
	2000	280	2309	4000
	2250	315	2598	4500
	2500	350	2887	5000
	2750	385	3175	5500
	3000	420	3464	6000
	3250	455	3753	6500
	3500	489	4041	7000
	3750	524	4330	7500
	4000	559	4619	8000
	4250	594	4907	8500
	4500	629	5169	9000
	4750	664	5485	9500
	5000	699	5774	10000
5250	734	6062	10500	
5500	769	6351	11000	

Line Length (mm)

7. Applications

The Laserlyte-Flex Alignment System has many applications, some of which are shown below along with the recommended product.



Edge Alignment

Laserlyte-Flex 635nm, 5mW, 90° Line

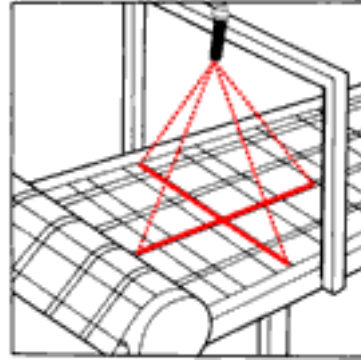

Pattern Alignment

Laserlyte-Flex 635nm, 5mW, 60° Cross

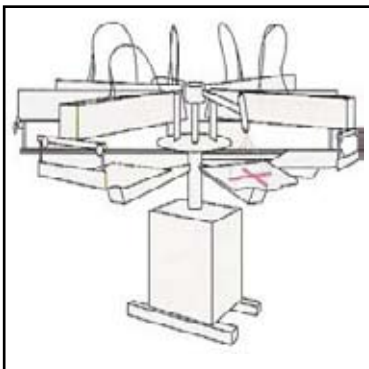

Screen Printing

Laserlyte-Flex 635nm, 5mW, 60° Cross

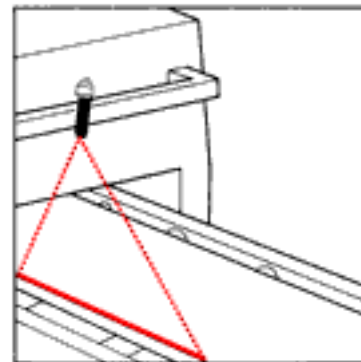

Garment Positioning

Laserlyte-Flex 635nm, 5mW, 90° Line

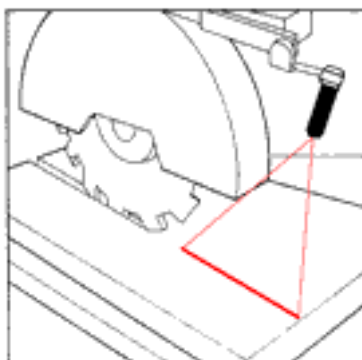

Cutting Guidance

Laserlyte-Flex 635nm, 5mW, 90° Line

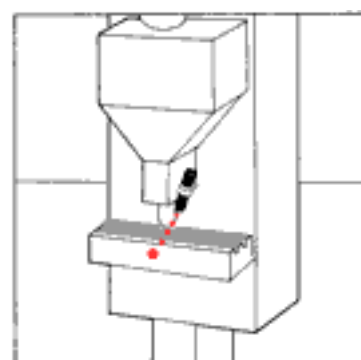

Machine Alignment

Laserlyte-Flex 650nm, 5mW, Dot

8. Warranty & Repair

If your product develops a fault within 12 months from the date of purchase Global Laser will repair / replace the product. If you wish to return a faulty product contact your local representative or Global Laser to obtain a RMA (Return Material Authorisation code) and return to the address below:

Global Laser Ltd
Units 9-10
Roseheyworth Business Park
Abertillery
Gwent, NP13 1SP
United Kingdom

9. Safety & Classification

These modules are intended for incorporation into customer equipment. They are classified in accordance with IEC60825-1 2007, which should be consulted prior to designing or using any laser product. The following labels are supplied for attachment to the customer's equipment, but responsibility for compliance with the standard remains with the user.

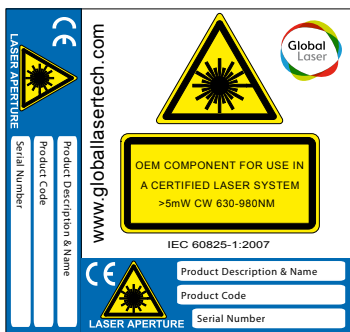

OEM Laser Label

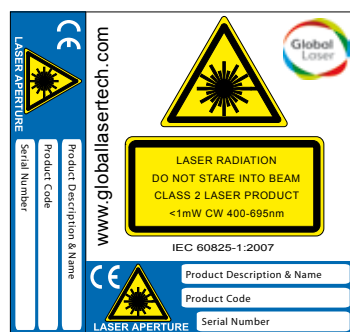

Class 2 Laser Label

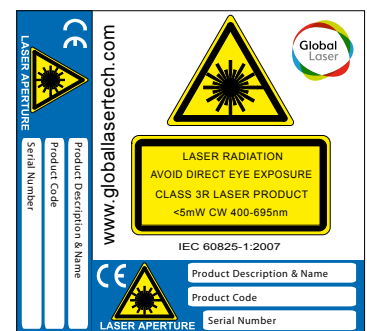

Class 3R Laser Label

10. Diagrams

A) Laserlyte-Flex and Line/Cross Optics

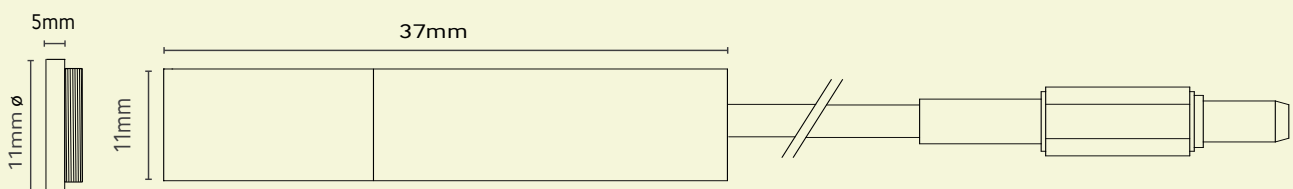

B) Heavy Duty Mounting Clamp

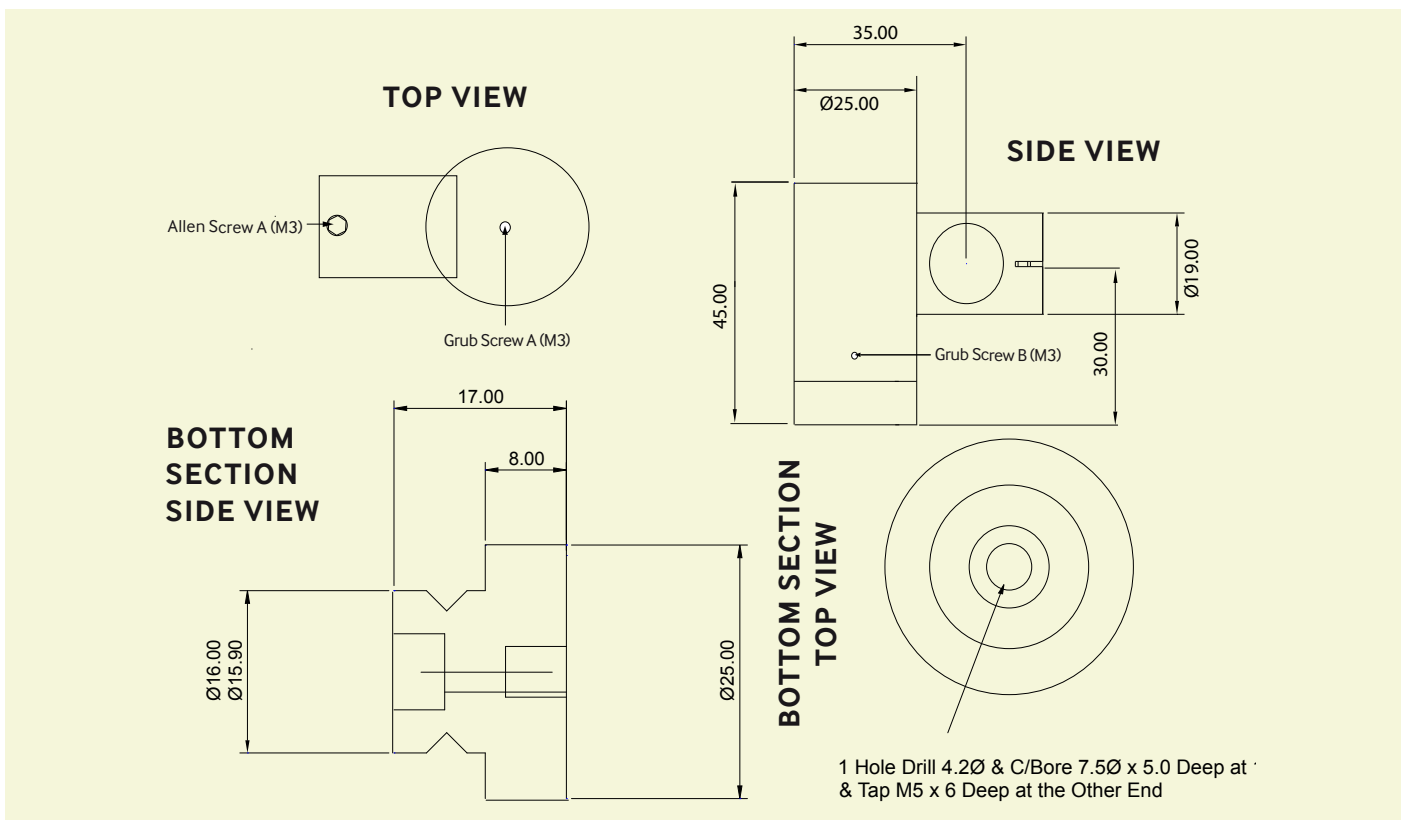

C) MK1 Mounting Clamp

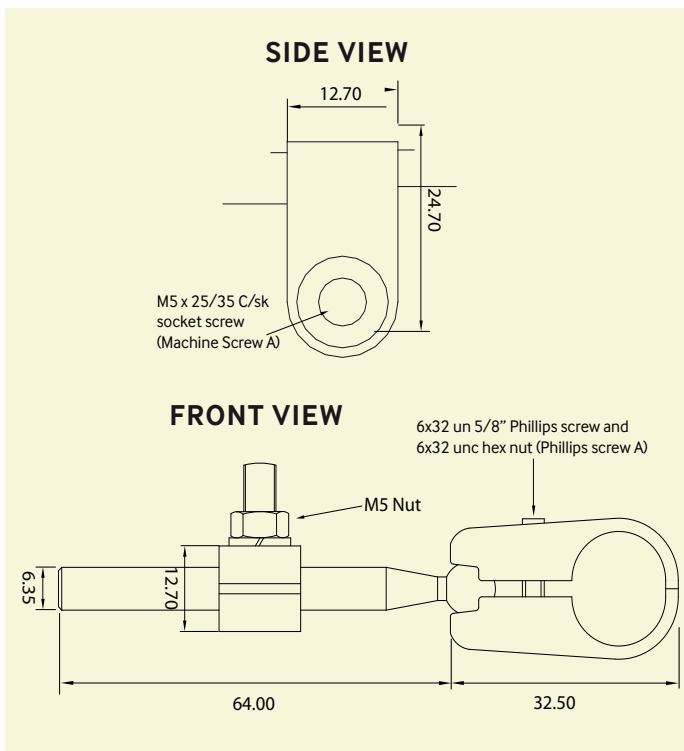

D) Magnetic Base

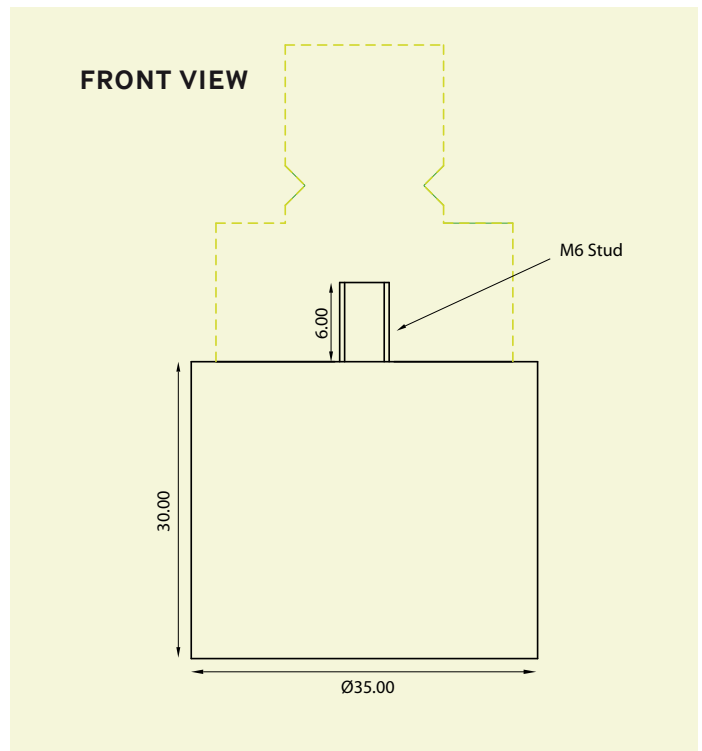

Please Note: Global Laser reserve the right to change descriptions and specifications without notice.



T: +44 (0)1495 212213
 F: +44 (0)1495 214004
 E: sales@globallasertech.com
 www.globallasertech.com

Global Laser Ltd
 Units 9-10
 Roseheyworth Business Park
 Abertillery, Gwent NP13 1SP UK