

THIS DRAWING IS UNPUBLISHED. RELEASED FOR PUBLICATION
 © COPYRIGHT BY TYCO ELECTRONICS CORPORATION. ALL RIGHTS RESERVED.

LOC	DIST	REVISIONS					
GP	00	P	LTR	DESCRIPTION	DATE	DWN	APVD
		S		ADDED 9--0 PER EC OS12-0217-03	12MAY03	AWF	AWF

.050±.005 DIA
 SECTION A-A
 SCALE 10:1
 10 PLACES

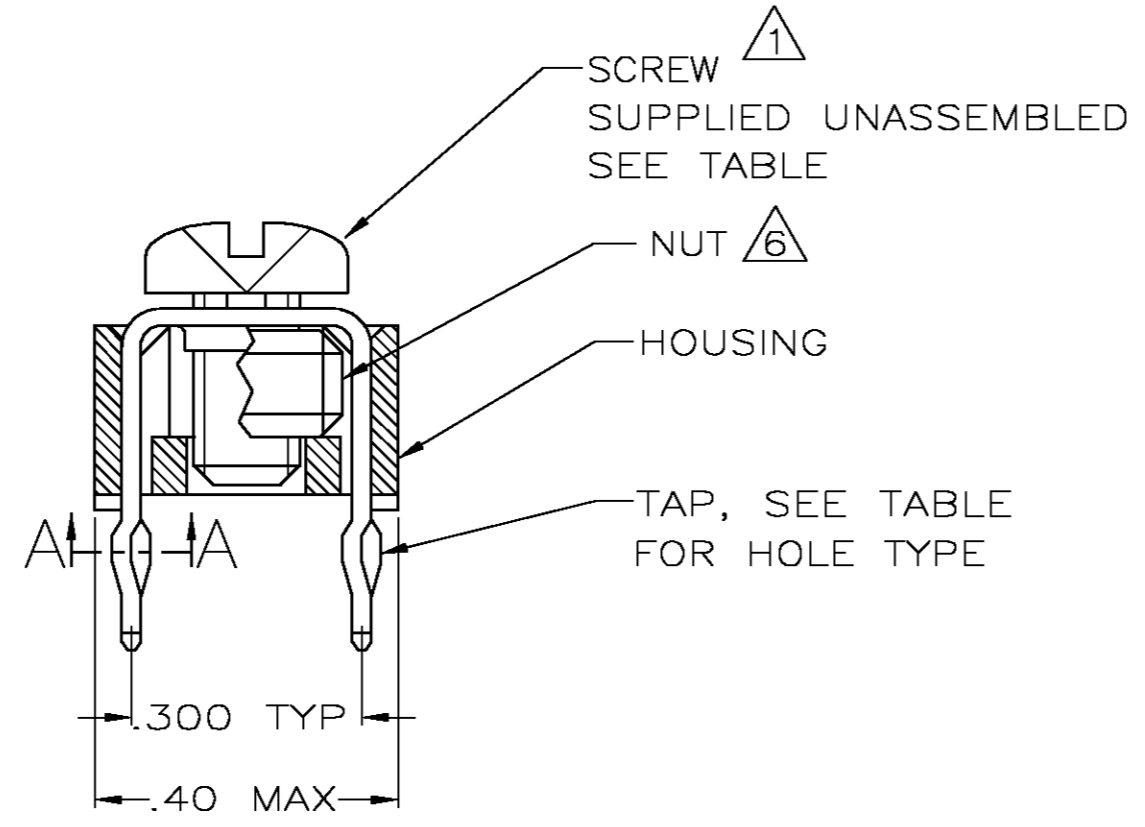
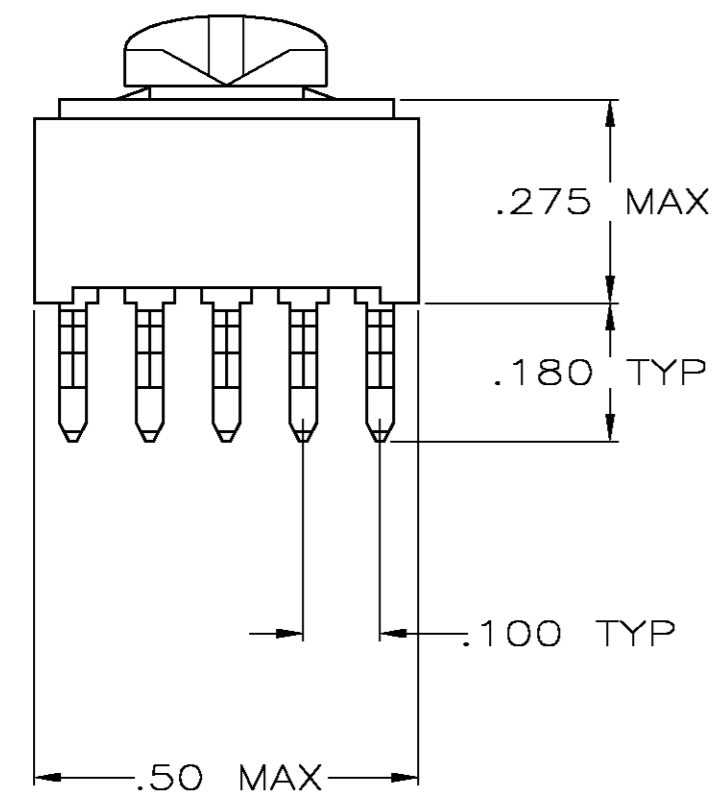

- 1 TO PREVENT THREAD STRIPPING, SCREW TORQUE SHOULD NOT EXCEED 9 IN LBS.
- 2 TAP HOLE IS 6-32UNC-2B, TWO MIN THREADS.
- 3 TAP HOLE IS M4 X 0.7, TWO MIN THREADS.
- 4 PACKAGED BULK.
- 5 PACKAGED INDIVIDUALLY.
- 6 NUT INCREASES TORQUE VALUE TO 26 IN LBS.
- 7 HOUSING: NYLON UL 94V-0. TAP: COPPER ALLOY 735, .025 THICK.
- 8 TAP: .000150 TIN-LEAD OVER .000050 NICKEL.
- 9 CLEARANCE HOLE FOR A 6-32 SCREW.
- 10 TAP: .000150 TIN OVER .000050 NICKEL.

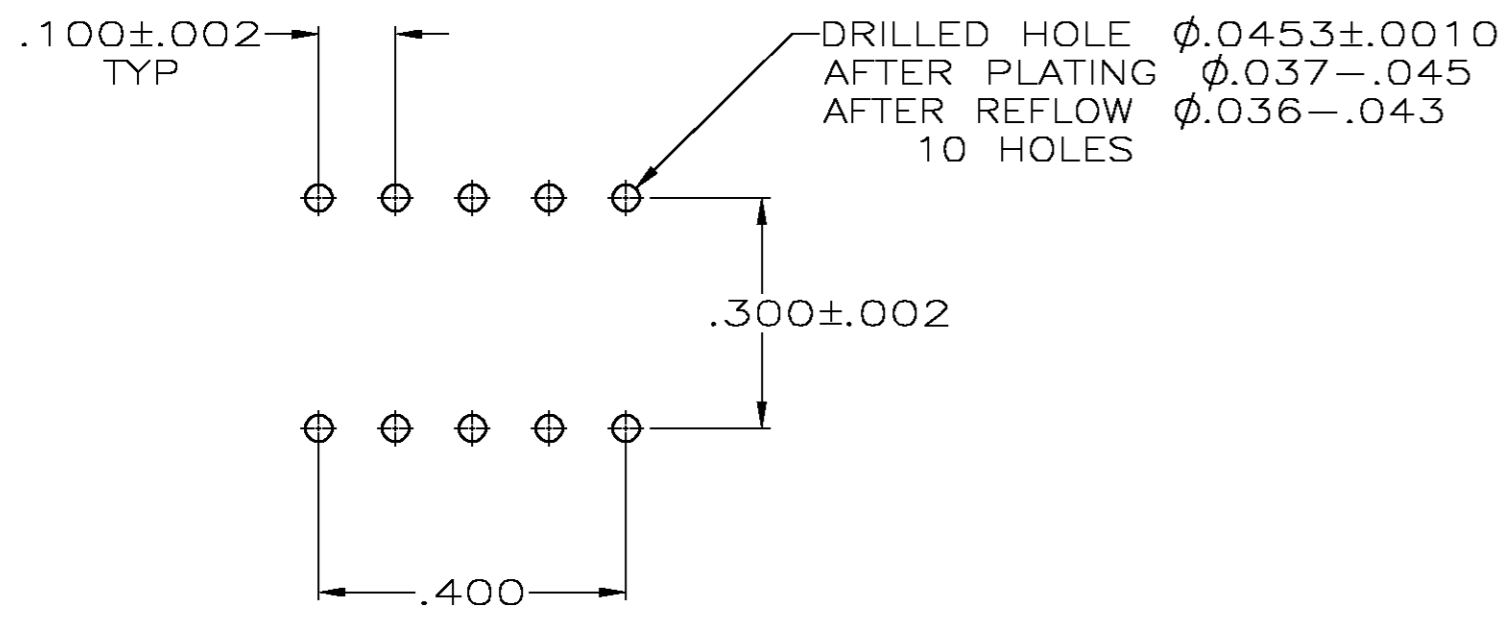

PC BOARD PATTERN

PACKAGE	FINISH	HOLE TYPE	HOUSING COLOR	HOUSING AND TAP ASSEMBLED	SCREW	PART NO.
	4	10	2	BLACK	YES	993879-1 9-55556-0
	4	8	9	BLACK	6 YES (W/NUT)	NO 1-55556-3
	4	8	9	BLACK	6 YES (W/NUT)	993879-1 1-55556-2
OBSOLETE	5	8	2	BLACK	YES	993879-1 1-55556-1
SUPSD BY -9	-	8	3	BLACK	YES	NO 1-55556-0
	4	8	3	BLACK	YES	M4 X 0.7 X 6MM 55556-9
SUPSD BY -4	-	8	2	WHITE	YES	993879-1 55556-8
SUPSD BY -4	-	8	2	GREEN	YES	993879-1 55556-7
SUPSD BY -4	-	8	2	BLUE	YES	993879-1 55556-6
SUPSD BY -4	-	8	2	RED	YES	993879-1 55556-5
	4	8	2	BLACK	YES	993879-1 55556-4
	4	8	2	BLACK	YES	NO 55556-3
OBSOLETE	-	8	2	BLACK	NO	993879-1 55556-2
	-	8	2	BLACK	NO	NO 55556-1

THIS DRAWING IS A CONTROLLED DOCUMENT.

DIMENSIONS: INCHES	TOLERANCES UNLESS OTHERWISE SPECIFIED:	DWN: J.McCLINTON 1-11-88	Tyco Electronics Corporation Harrisburg, PA, 17105
	0 PLC ± -	CHK: R.STONE 1-11-88	
	1 PLC ± -	APVD: M.GALLOWAY 1-11-88	
	2 PLC ± -	NAME: TAP ASSEMBLY, POWER DISTRIBUTION	
	3 PLC ± .010	PRODUCT SPEC: 108-11030	SIZE: A2
	4 PLC ± -	APPLICATION SPEC: 114-1100	CAGE CODE: 00779
	ANGLES ± -	WEIGHT:	DRAWING NO: C=55556
MATERIAL: 7	FINISH:	CUSTOMER DRAWING	RESTRICTED TO:

SCALE 4:1 SHEET 1 OF 1 REV S

55556

A