

4

3

2

1

THIS DRAWING IS UNPUBLISHED. RELEASED FOR PUBLICATION AUG ,2006.

© COPYRIGHT BY TYCO ELECTRONICS CORPORATION. ALL RIGHTS RESERVED.

LOC		DIST		REVISIONS			DATE	DWN	APVD
P	LTR	DESCRIPTION							
DW	-	M1	REVISED (ECR-10-023929, ECR-10-024144)			23NOV10	SC	WK	

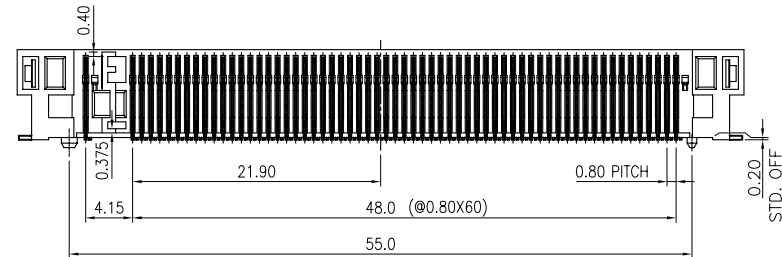
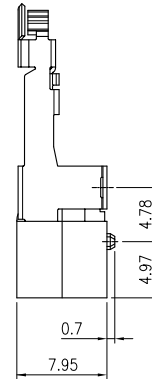
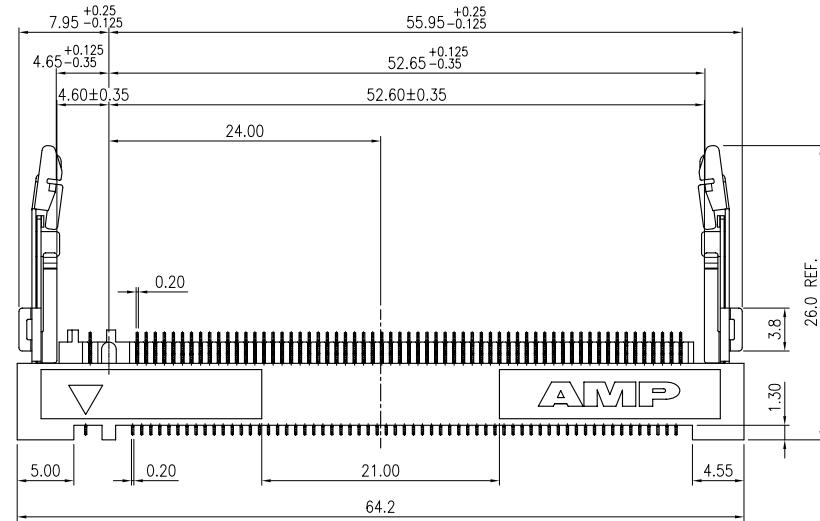
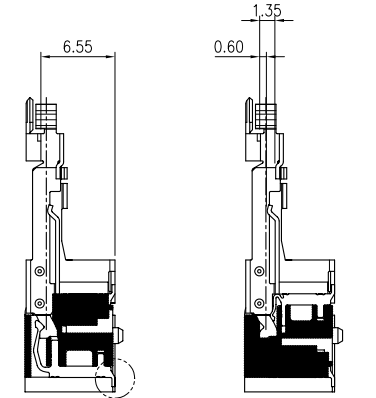
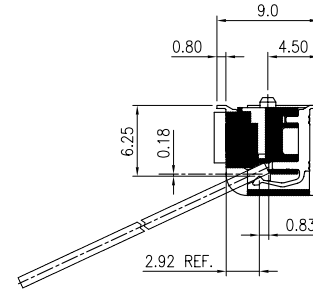
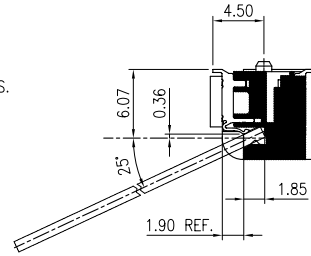
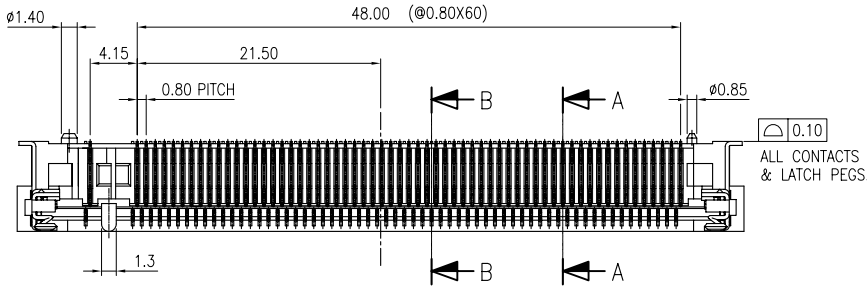

NOTE :

- MATERIAL
HOUSING : THERMOPLASTIC, LCP
UL 94V-0, BLACK COLOR
CONTACT : COPPER ALLOY
LATCH : STEEL
- FINISH
CONTACT : 0.25um MIN. GOLD PLATED IN CONTACT AREA,
GOLD FLASH PLATING ALL OVER, WITH
1.27um MIN. NICKEL UNDERPLATING ALL OVER.
LATCH : 2.54um MIN. MATTE TIN PLATING(SEE TABLE) OVER
0.76um MIN. NICKEL PLATING.
- CARD THICKNESS APPLIES ACROSS TABS AND INCLUDES PLATING
AND/OR METALIZATION
- APPLICATION
GOLD CONTACT PAD : ELECTROLESS GOLD PLATING 0.05um MIN
OVER ELECTROLESS NICKEL PLATING 2um MIN
- BORDER OF COMPONENT AREA
- WEIGHT
NET WEIGHT : 3.45 kgs/CTN
GROSS WEIGHT : 8 kgs/CTN

W/O	WHITE	440360-4
	TRANSPARENT	440360-2
HOLE	TRAY COLOR	PART NUMBER

THIS DRAWING IS A CONTROLLED DOCUMENT.		DWN S. HOU 11MAR2008	Tyco Electronics Corporation Taipei, Taiwan	
DIMENSIONS: MM		CHK W. KODAMA 11MAR2008	NAME	
TOLERANCES UNLESS OTHERWISE SPECIFIED:		APVD W. KODAMA 11MAR2008	0.8mm PITCH FAX MODEM SOCKET, 124 POSITIONS.	
0 PLC ± -		PRODUCT SPEC	SIZE CAGE CODE DRAWING NO RESTRICTED TO	
1 PLC ± 0.15		108-57083	A3 00779 C-440360	
2 PLC ± 0.1		QUALIFICATION TEST REPORT	SCALE SHEET 1 OF 6 REV M1	
3 PLC ± 0.05		501-57035		
4 PLC ± -		WEIGHT 5.75 GRAMS		
ANGLES ± -		CUSTOMER DRAWING		
MATERIAL SEE NOTE				
FINISH SEE NOTE				

4

3

2

1

THIS DRAWING IS UNPUBLISHED. RELEASED FOR PUBLICATION AUG ,2006.

© COPYRIGHT BY TYCO ELECTRONICS CORPORATION. ALL RIGHTS RESERVED.

LOC	DIST	REVISIONS			
P	LTR	DESCRIPTION	DATE	DWN	APVD
DW	—	SEE SHEET 1			

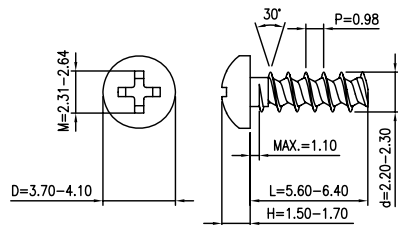
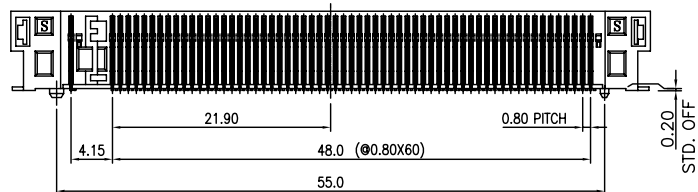
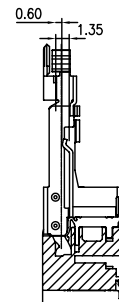
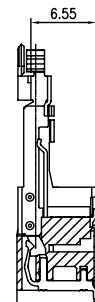
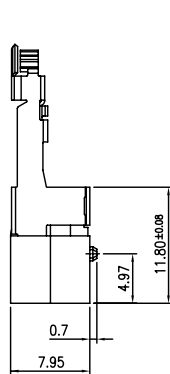
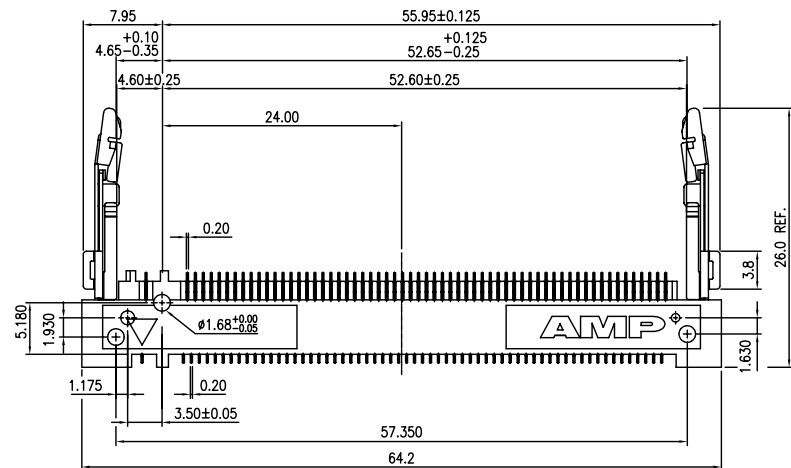
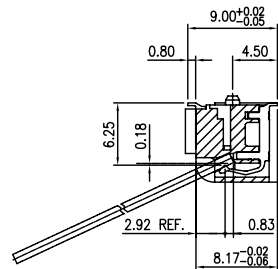
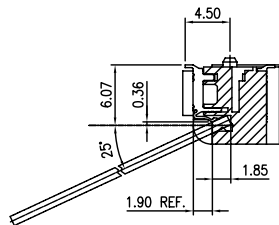
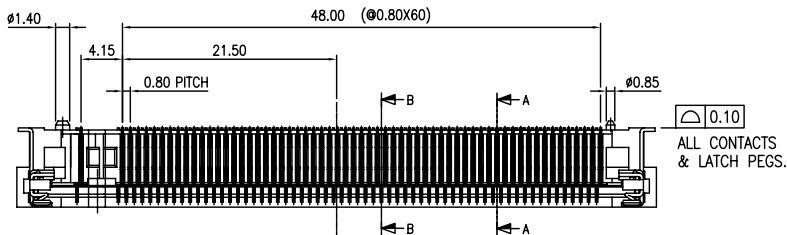

SCALE 4:1

M2.2X6 PT30 RECOMMENDED SCREW

- NOTE:
 1. SCREW LOCATION AS APPLICABLE PER CUSTOMER.
 2. RECOMMENDED SCREW : M2.2 X 6, PT 30 OR EQUIVALENT SCREW FOR THERMOPLASTIC.
 3. TORQUE SCREWS TO 38-48 OZF-IN.

w/	WHITE	1-440360-4
	TRANSPARENT	1-440360-2
HOLE	TRAY COLOR	PART NUMBER

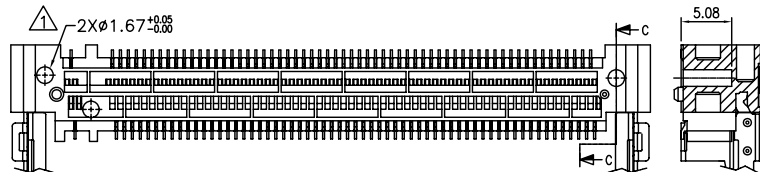

THIS DRAWING IS A CONTROLLED DOCUMENT.

DIMENSIONS: MM	TOLERANCES UNLESS OTHERWISE SPECIFIED:	DWN S. HOU 11MAR2008	Tyco Electronics Corporation Taipei, Taiwan
0 PLC ± -	1 PLC ± 0.15	CHK W. KODAMA 11MAR2008	
2 PLC ± 0.1	3 PLC ± 0.05	APVD W. KODAMA 11MAR2008	NAME
4 PLC ± -	ANGLES ± -	PRODUCT SPEC	108-57083
MATERIAL SEE NOTE	FINISH SEE NOTE	QUALIFICATION TEST REPORT	501-57035
		WEIGHT	5.75 GRAMS
		CUSTOMER DRAWING	A3 00779 C=440360

SIZE	CAGE CODE	DRAWING NO	RESTRICTED TO
A3	00779	C=440360	—
SCALE	SHEET	REV	
—	2 OF 6	M1	

LOC	DIST	REVISIONS			
P	LTR	DESCRIPTION	DATE	DWN	APVD
DW	-				
SEE SHEET 1					

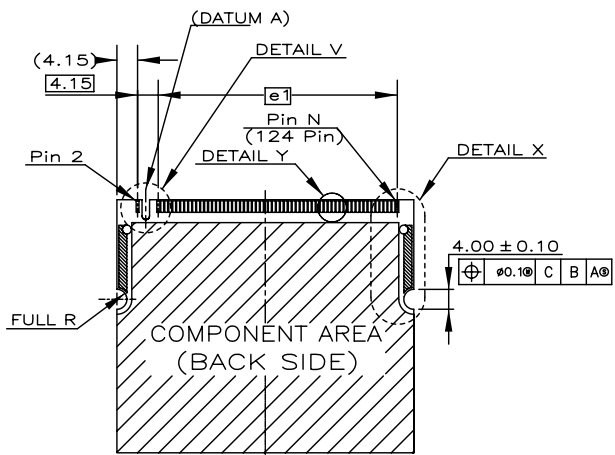
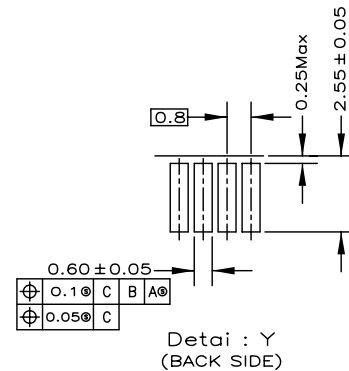
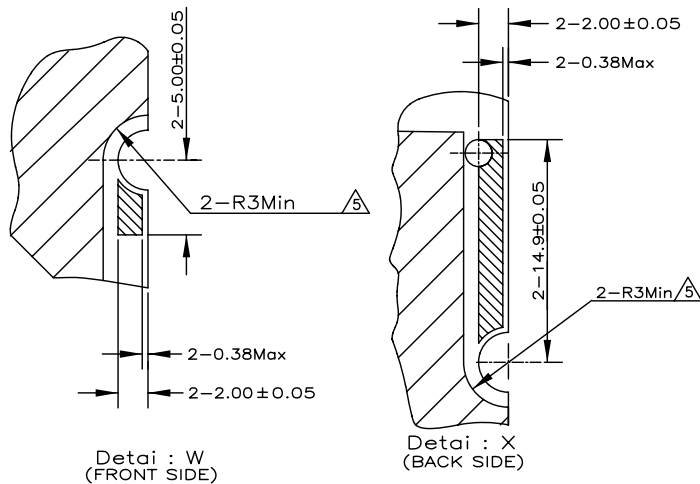
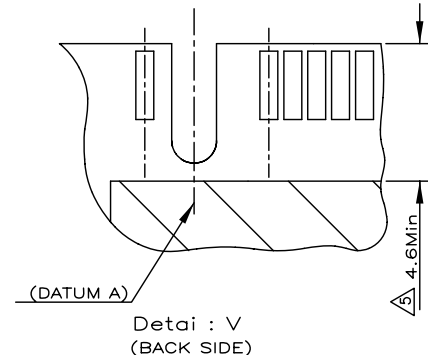
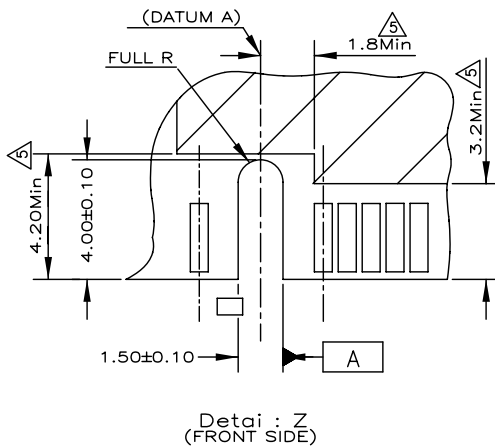
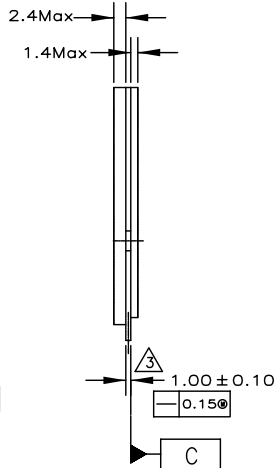
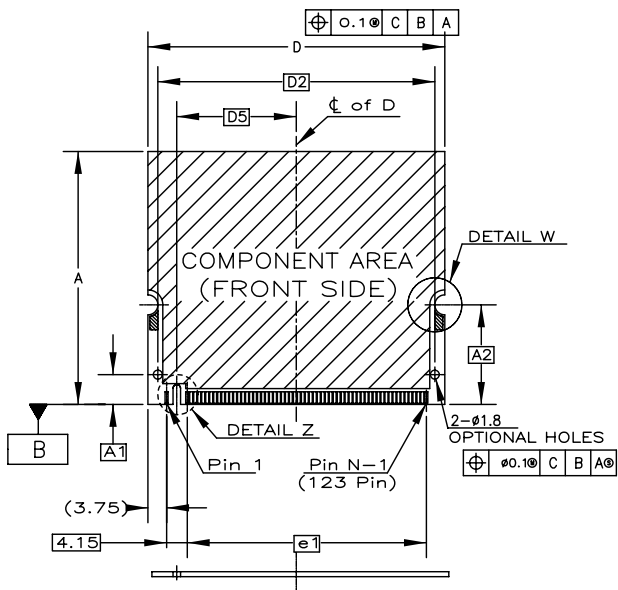

THIS DRAWING IS A CONTROLLED DOCUMENT.		DWN S. HOU 11MAR2008	Tyco Electronics Corporation Taipei, Taiwan													
DIMENSIONS: MM		CHK W. KODAMA 11MAR2008	NAME													
TOLERANCES UNLESS OTHERWISE SPECIFIED:		APVD W. KODAMA 11MAR2008														
<table border="1"> <tr><td>0 PLC</td><td>± -</td></tr> <tr><td>1 PLC</td><td>± -</td></tr> <tr><td>2 PLC</td><td>± -</td></tr> <tr><td>3 PLC</td><td>± -</td></tr> <tr><td>4 PLC</td><td>± -</td></tr> <tr><td>ANGLES</td><td>± -</td></tr> </table>		0 PLC	± -	1 PLC	± -	2 PLC	± -	3 PLC	± -	4 PLC	± -	ANGLES	± -	PRODUCT SPEC	0.8mm PITCH FAX MODEM SOCKET, 124 POSITIONS.	
0 PLC	± -															
1 PLC	± -															
2 PLC	± -															
3 PLC	± -															
4 PLC	± -															
ANGLES	± -															
MATERIAL		QUALIFICATION TEST REPORT	SIZE A3	CAGE CODE 00779												
		WEIGHT	DRAWING NO C=440360	RESTRICTED TO												
CUSTOMER DRAWING			SCALE -	SHEET 4 OF 6												
				REV M1												

4

3

2

1

THIS DRAWING IS UNPUBLISHED.

RELEASED FOR PUBLICATION

AUG ,2006.

© COPYRIGHT BY TYCO ELECTRONICS CORPORATION.

ALL RIGHTS RESERVED.

LOC DW

DIST -

REVISIONS

P	LTR	DESCRIPTION	DATE	DWN	APVD
		SEE SHEET 1			

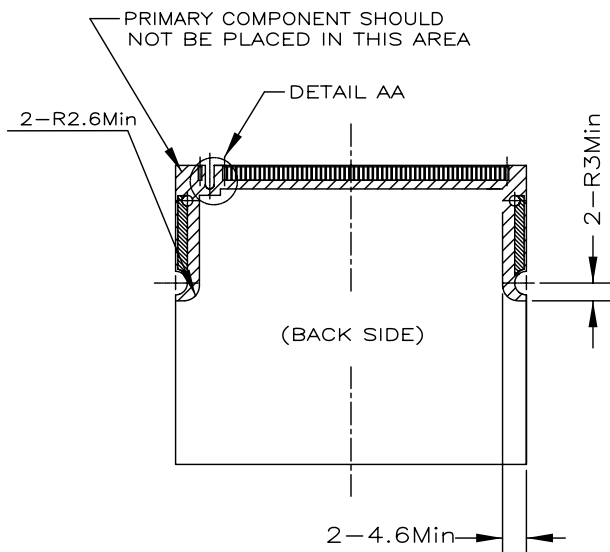
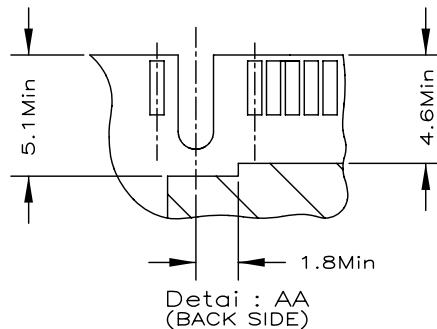
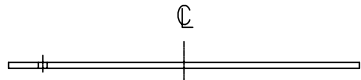
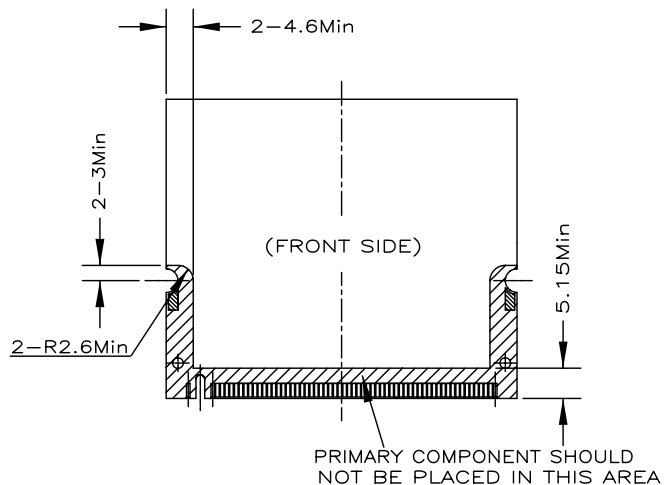

SOYMBOL	VARIATIONS ALL DIMENSIONS IN mm					
	NORMAL HEIGHT 44.45			NORMAL HEIGHT 50.80		
	AA			BA		
	MIN	NOM	MAX	MIN	NOM	MAX
A	44.3	44.45	44.60	50.65	50.80	50.95
A1	6.00	BSC		6.00	BSC	
A2	20.00	BSC		20.00	BSC	
D	59.45	59.6	59.75	59.45	59.6	59.75
D1	1.30	BSC		1.30	BSC	
D2	55.60	BSC		55.60	BSC	
D3	2.05	BSC		2.05	BSC	
D4	1.65	BSC		1.65	BSC	
D5	24.00	BSC		24.00	BSC	
e1	48.00	BSC		48.00	BSC	
N		124			124	

THIS DRAWING IS A CONTROLLED DOCUMENT.

DIMENSIONS: MM



TOLERANCES UNLESS OTHERWISE SPECIFIED:

- 0 PLC ± -
- 1 PLC ± -
- 2 PLC ± -
- 3 PLC ± -
- 4 PLC ± -
- ANGLES ± -

MATERIAL -

FINISH -

DWN S. HOU 11MAR2008

CHK W. KODAMA 11MAR2008

APVD W. KODAMA 11MAR2008

PRODUCT SPEC -

QUALIFICATION TEST REPORT -

WEIGHT -

CUSTOMER DRAWING



Tyco Electronics Corporation
Taipei, Taiwan

NAME

0.8mm PITCH FAX MODEM
SOCKET, 124 POSITIONS.

SIZE CAGE CODE DRAWING NO RESTRICTED TO

A3 00779 C=440360

SCALE SHEET 5 of 6 REV M1

4

3

2

1

THIS DRAWING IS UNPUBLISHED.

RELEASED FOR PUBLICATION

AUG ,2006.

© COPYRIGHT BY TYCO ELECTRONICS CORPORATION.

ALL RIGHTS RESERVED.

LOC DW

DIST -

REVISIONS

P	LTR	DESCRIPTION	DATE	DWN	APVD
		SEE SHEET 1			

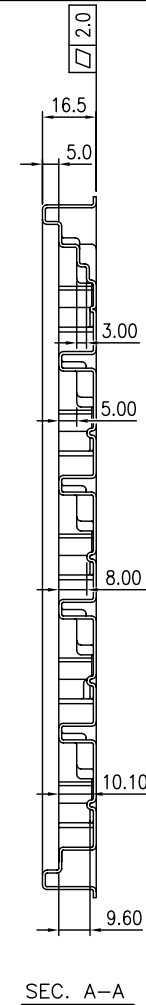
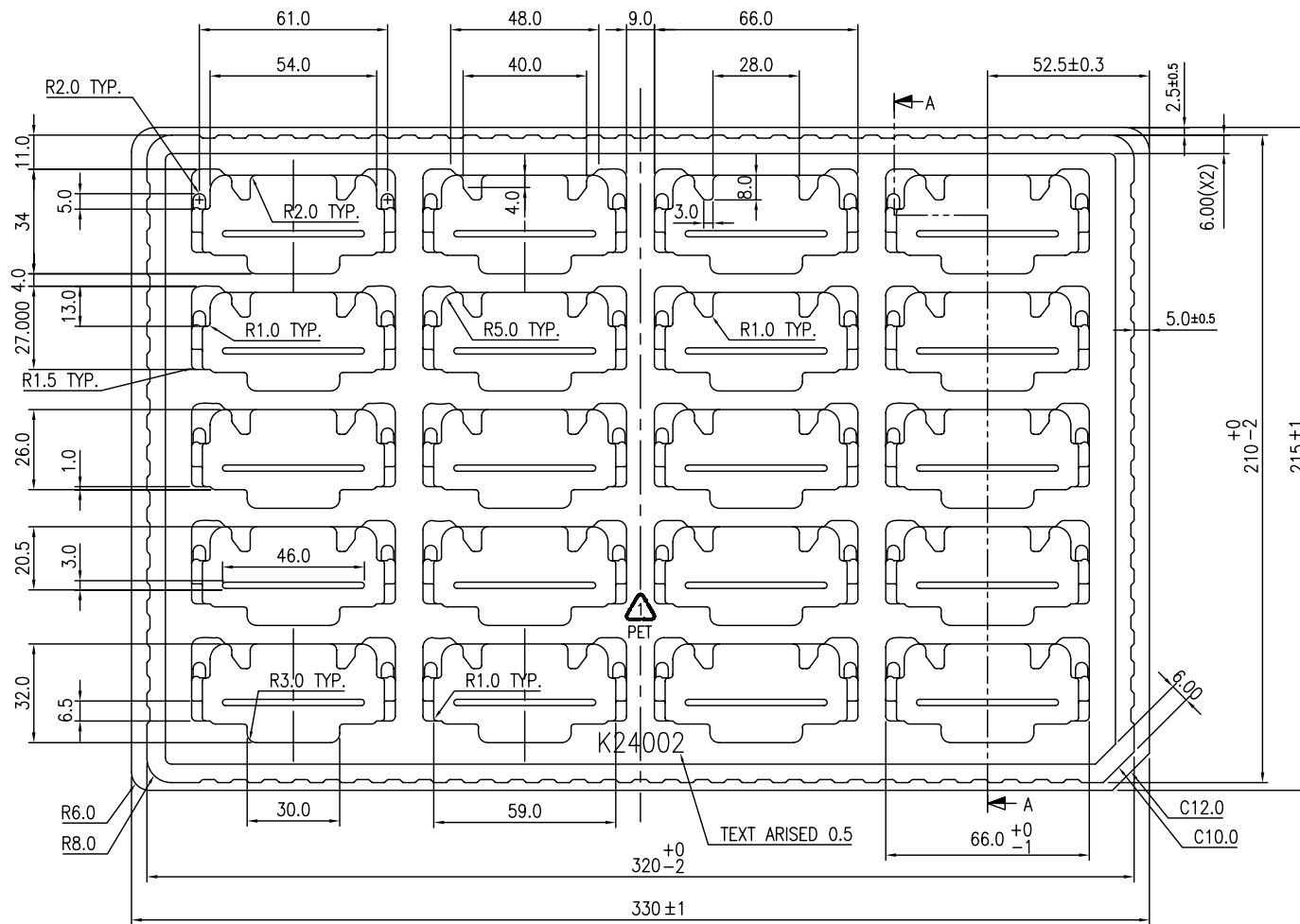

NOTES:

1. MATERIAL: PET, t=0.9 ± 0.20 mm.
2. ALLOWED RADIUS R0.5 UNLESS OTHERWISE SPECIFIED.
3. DRAFT ANGLE: 3° MAX.
4. PACKAGE: 30 TRAYS/CARTON, TOTAL: 600 PCS.

THIS DRAWING IS A CONTROLLED DOCUMENT.		DWN S. HOU 11MAR2008	Tyco Electronics Corporation Taipei, Taiwan	
DIMENSIONS: MM		CHK W. KODAMA 11MAR2008	NAME	
TOLERANCES UNLESS OTHERWISE SPECIFIED:		APVD W. KODAMA 11MAR2008	0.8mm PITCH FAX MODEM SOCKET, 124 POSITIONS.	
0 PLC ± -		PRODUCT SPEC	SIZE A3	CAGE CODE 00779
1 PLC ± -		QUALIFICATION TEST REPORT	DRAWING NO C=440360	RESTRICTED TO
2 PLC ± -		WEIGHT	SCALE -	SHEET 6 OF 6
3 PLC ± -		CUSTOMER DRAWING	REV M1	
4 PLC ± -				
ANGLES ± -				
FINISH				
MATERIAL				