

TITLE : PLCC SOCKET SURFACE MOUNT - WPLCC(XXX)-1ST iss2

DIM. mm

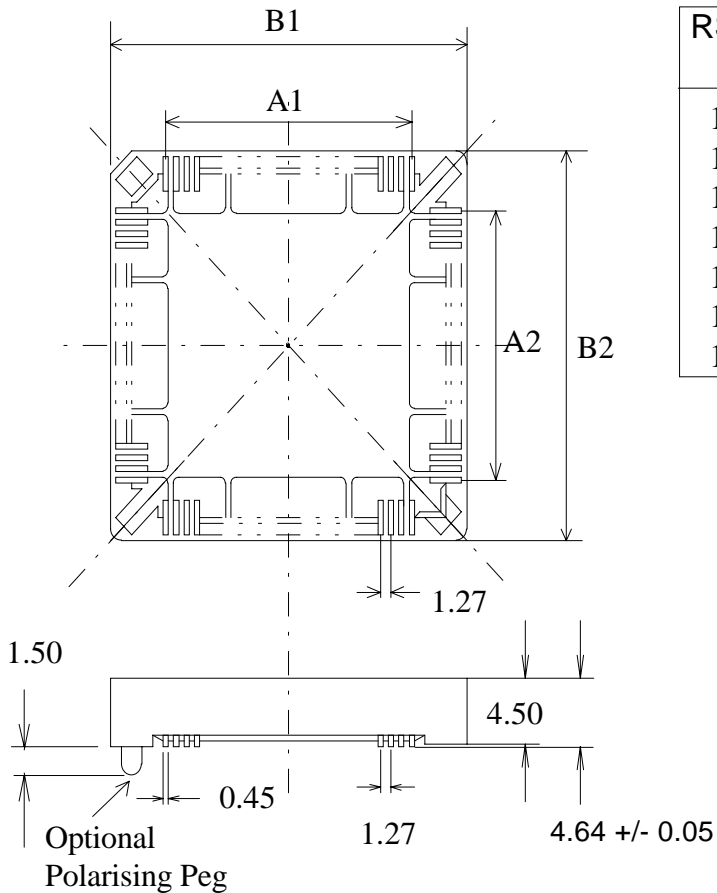

| RS Stock NO. | No. OF PINS | DIMENSIONS | | WINSLOW PART NO. |
|--------------|-------------|-------------|--------------|------------------|
| | | A | B | |
| 180 7644 | 20 | 5.08 | 15.58 | WPLCC020-1ST |
| 180 7650 | 28 | 7.62 | 18.12 | WPLCC028-1ST |
| 180 7666 | 32 | 7.62*10.16* | 18.12*20.66* | WPLCC032-1ST |
| 180 7672 | 44 | 12.70 | 23.20 | WPLCC044-1ST |
| 180 7694 | 52 | 15.24 | 25.74 | WPLCC052-1ST |
| 180 7701 | 68 | 20.32 | 30.82 | WPLCC068-1ST |
| 180 7717 | 84 | 25.40 | 35.90 | WPLCC084-1ST |

* Rectangular Socket

| | |
|-------------------------------|--------------------------|
| Voltage Rating | AC 100VRMS/ DC 150V |
| Current Rating | 1 Amp |
| Contact Resistanc | 30 m Ohm max |
| Insulation Resistance | 1000M Ohm min at DC 100V |
| Withstanding Voltage | AC 600VRMS for 1 minute |
| Operating Temp (PPS) | -55 deg C to +125 deg C |
| Operating Tmep (LCP) | -55 deg C to +230 deg C |
| Applied (Wave Soldering)(PPS) | +240 deg C (max 15 sec) |
| Applied (Wave Soldering)(LCP) | +275 deg C (max 15 sec) |
| Durability | 100 cycles |
| Vibration | 10 000 to 20 000 Hz, 5Gs |
| Contact Material | Phospher Bronze |

TOL.
 0 +/- 1
 0.0 +/- 0.1
 0.00 +/- 0.01
 0.000 +/- 0.001

DWN. JGW

DATE. 22/10/97

SCALE.
 NTS

ISSUE.
 RS 02

MODIFICATIONS.

NONE

WINSLOW INTERNATIONAL Ltd.

ADAPTICS HOUSE, BRECON ENTERPRISE PARK.
 BRECON. POWYS. LD3 8EF.

Tel : 0044 (0)1874 625555 Fax : 0044 (0)1874 625500

DEVICES. GENERIC
 for details of suitable devices please contact factory.