

The General Purpose Bearing – iglidur® G: the most sold iglidur® bearing worldwide



Over 650 sizes available ex stock

Maintenance-free, dry running

High wear resistance

Resistance to dust and dirt

Cost-effective

iglidur® G | The General Purpose Bearing

Most popular iglidur® material worldwide. iglidur® G bearings cover an extremely wide range of different requirements – they are truly “all round”. Typical applications include medium to high loads, medium sliding speeds and medium temperatures.



When to use it?

- Economical all-round performance bearing
- Maintenance-free, dry running
- Vibration dampening
- High wear resistance
- Resistance to dust and dirt
- Over 900 sizes available from stock
- Cost-effective
- For above average loads
- For low to average running speeds
- When the bearing needs to run on different shaft materials
- For oscillating and rotational movements



When not to use it?

- When mechanical reaming of the wall surface is necessary
 - ▶ iglidur® M250, page 111
- When the highest wear resistance is required
 - ▶ iglidur® W300, page 135
- When universal chemical resistance is required iglidur®X, page 157
- If temperatures are constantly greater than +130 °C
 - ▶ iglidur® H, page 337
 - ▶ iglidur® X, page 157
 - ▶ iglidur® H370, page 359
- For underwater use
 - ▶ iglidur® H370, page 359

Temperature

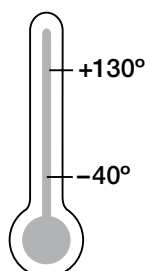

Product range

3 types
> 650 dimensions
Ø 1.5–150 mm



iglidur® G | Application Examples



Typical sectors of industry and application areas

- Agricultural machines
- Construction machinery
- Machine building
- Sports and leisure
- Automotive etc.

Improve technology and reduce costs – 310 exciting examples for iglidur® plain bearings online

► www.igus.eu/iglidur-applications



► www.igus.eu/hay-spreader



► www.igus.eu/vehicle-construction



► www.igus.eu/swing-arm



► www.igus.eu/veneer-assembling

Material properties table

General properties	Unit	iglidur® G	Testing method
Density	g/cm ³	1.46	
Colour		dark grey	
Max. moisture absorption at +23 °C/50 % r.h.	% weight	0.7	DIN 53495
Max. water absorption	% weight	4.0	
Coefficient of sliding friction, dynamic against steel	μ	0.08–0.15	
pv value, max. (dry)	MPa · m/s	0.42	
Mechanical properties			
Modulus of elasticity	MPa	7,800	DIN 53457
Tensile strength at +20 °C	MPa	210	DIN 53452
Compressive strength	MPa	78	
Max. recommended surface pressure (+20 °C)	MPa	80	
Shore D hardness		81	DIN 53505
Physical and thermal properties			
Max. long term application temperature	°C	+130	
Max. short term application temperature	°C	+220	
Min. application temperature	°C	-40	
Thermal conductivity	W/m · K	0.24	ASTM C 177
Coefficient of thermal expansion (at +23 °C)	K ⁻¹ · 10 ⁻⁵	9	DIN 53752
Electrical properties			
Specific volume resistance	Ωcm	> 10 ¹³	DIN IEC 93
Surface resistance	Ω	> 10 ¹¹	DIN 53482

Table 01: Material properties table

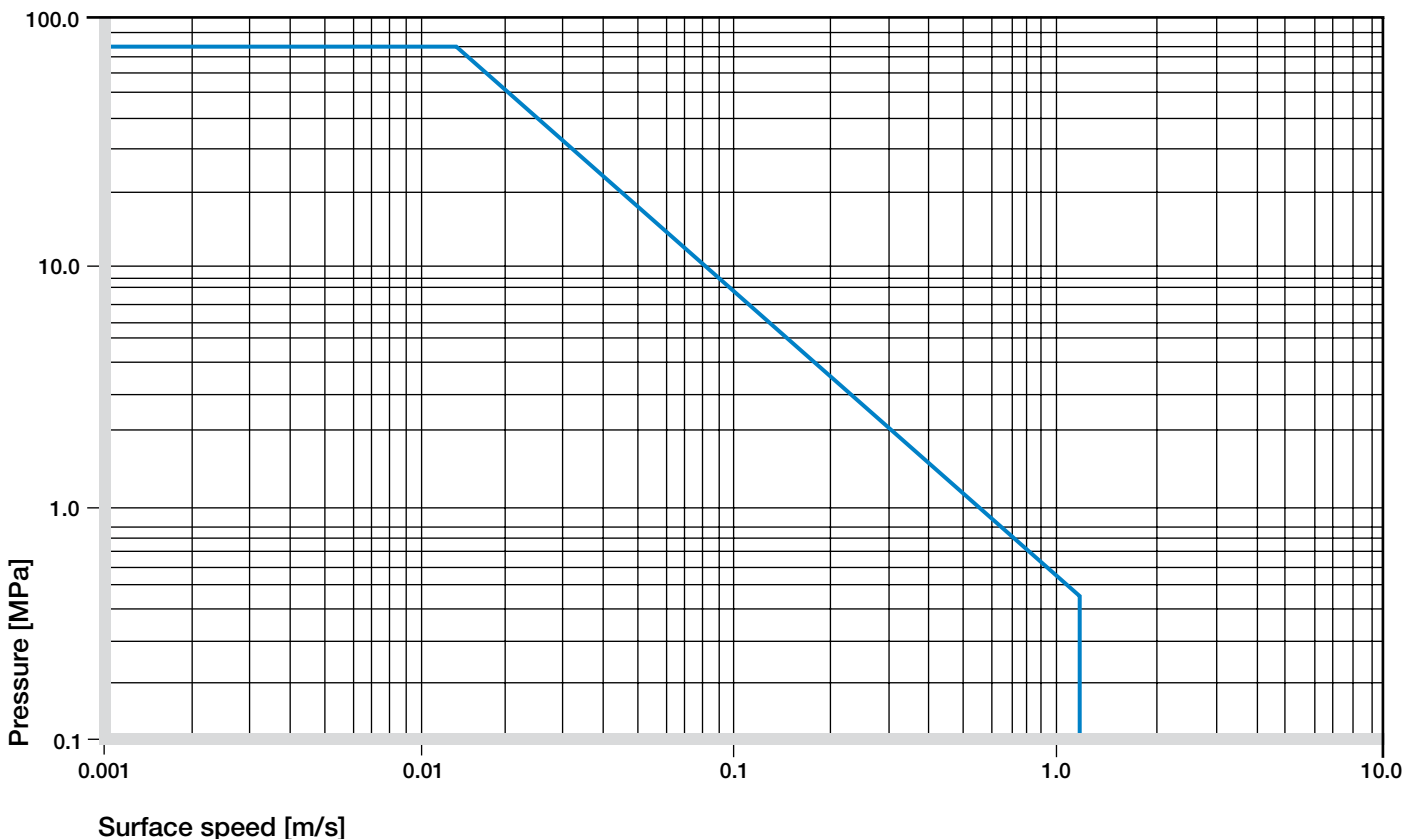

Graph 01: Permissible pv values for iglidur® G with a wall thickness of 1 mm dry running against a steel shaft at +20 °C, mounted in a steel housing

iglidur® G | Technical Data

iglidur® G is the decathlete among iglidur® materials. It performs exceedingly well in all technical disciplines and is the classic all-rounder, primarily with respect to the overall general, mechanical, thermal and tribological specifications.

Mechanical Properties

With increasing temperatures, the compressive strength of iglidur® G plain bearings decreases. The Graph 02 shows this inverse relationship. However, at the longterm maximum temperature of +130 °C the permissible surface pressure is almost 35 MPa. The recommended maximum surface pressure is a mechanical material parameter. No conclusions regarding the tribological properties can be drawn from this.

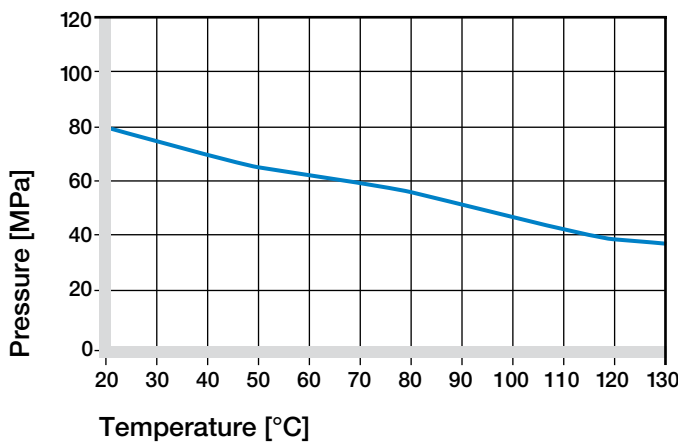

Graph 02: Recommended maximum surface pressure as a function of temperature (80 MPa at +20 °C)

Graph 03 shows the elastic deformation of iglidur® G during radial loading. At the recommended maximum surface pressure of 80 MPa the deformation is less than 4%. The plastic deformation is minimal up to a pressure of approximately 100 MPa. However, it is also dependant on the cycle time.

► Surface Pressure, page 47

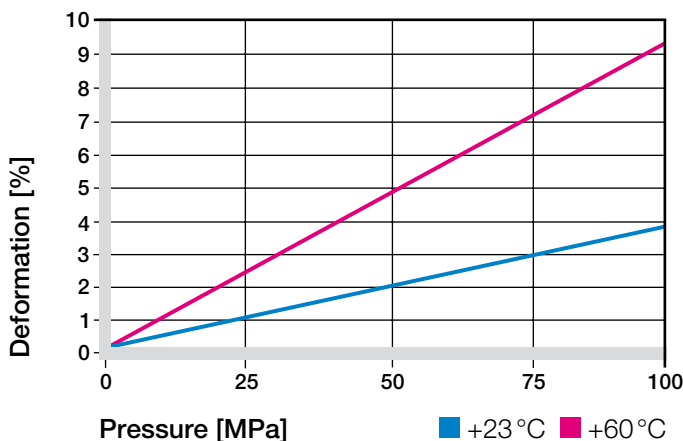

Graph 03: Deformation under pressure and temperature

Permissible Surface Speeds

iglidur® G has been developed for low to medium surface speeds.

The maximum values shown in table 02 can only be achieved at low pressures. At the given speeds, friction can cause a temperature increase to maximum permissible levels. In practice, though, this temperature level is rarely reached due to varying application conditions.

► Surface Speed, page 49

m/s	Rotating	Oscillating	Linear
Continuous	1	0.7	4
Short term	2	1.4	5

Table 02: Maximum running speed

Temperatures

Application temperatures greatly affect the properties of plain bearings.

The short term maximum temperature is +220 °C, this allows the use of iglidur® G plain bearings in heat treating applications in which the bearings are not subjected to additional loading.

The temperature in an application also has an effect on the bearing wear. With increasing temperatures, the wear increases and this effect is significant when temperatures rise over +120 °C.

► Application Temperatures, page 50

iglidur® G	Application temperature
Minimum	-40 °C
Max. long term	+130 °C
Max. short term	+220 °C
Add. securing is required from	+80 °C

Table 03: Temperature limits

Friction and Wear

Similar to wear resistance, the coefficient of friction μ also changes with the load. The coefficient of friction decreases with increasing pressures, whereas an increase in surface speed causes an increase of the coefficient of friction. This relationship explains the excellent results of iglidur® G plain bearings for high loads and low speeds (Graphs 04 and 05).

► Coefficients of Friction and Surfaces, **page 52**

► Wear Resistance, **page 53**

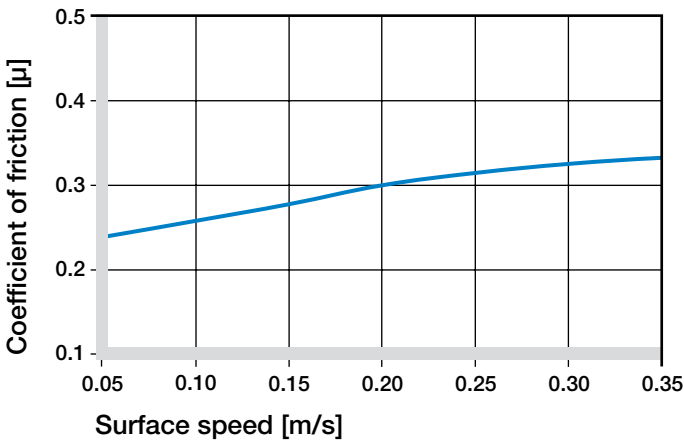

Graph 04: Coefficient of friction as a function of the running speed, $p = 0.75 \text{ MPa}$

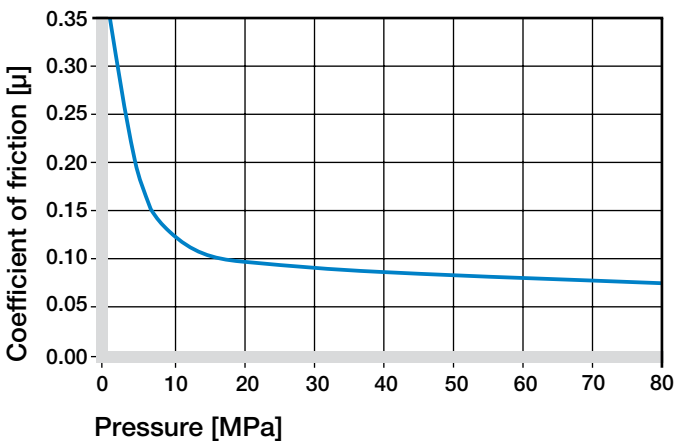

Graph 05: Coefficient of friction as a function of the pressure, $v = 0.01 \text{ m/s}$

Shaft Materials

The friction and wear are also dependent, to a large degree, on the shaft material. Shafts that are too smooth, increase both the coefficient of friction and the wear of the bearing. For iglidur® G a ground surface with an average roughness $R_a = 0.8 \mu\text{m}$ is recommended (Graph 06).

Graphs 07 to 09 show results of testing different shaft materials with plain bearings made of iglidur® G. In Graph 07 it shows that iglidur® G can be combined with various shaft materials. The simple shaft materials of free-cutting steel and HR carbon steel have proven best at low loads. This helps to design cost-effective systems, since both iglidur® G and the shaft are economically priced. It is important to notice that with increasing loads, the recommended hardness of the shaft increases. The “soft” shafts tend to wear more easily and thus the wear of the overall system. If the loads exceed 2 MPa it is important to recognize that the wear rate (the gradient of the curves) clearly decreases with the hard shaft materials. The comparison of rotational movements to oscillating movements shows that iglidur® G provides advantages in oscillating movements. The wear of the bearing is smaller for equivalent conditions. The higher the load, the greater the difference.

If the shaft material you plan on using is not shown in these test results, please contact us.

► Shaft Materials, **page 55**

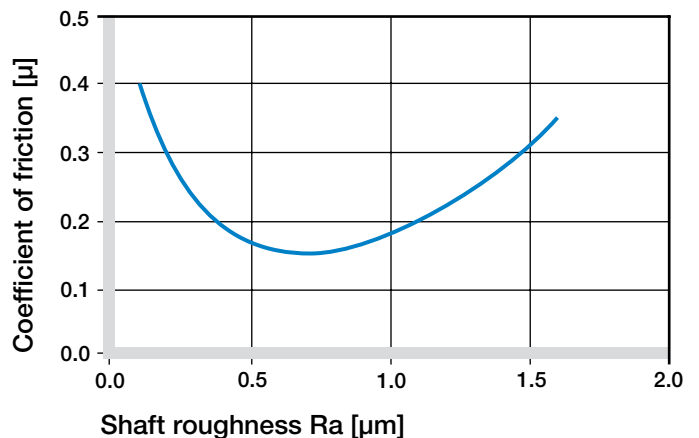

Graph 06: Coefficient of friction as function of the shaft surface (Cf53 hardened and ground steel)

iglidur® G | Technical Data

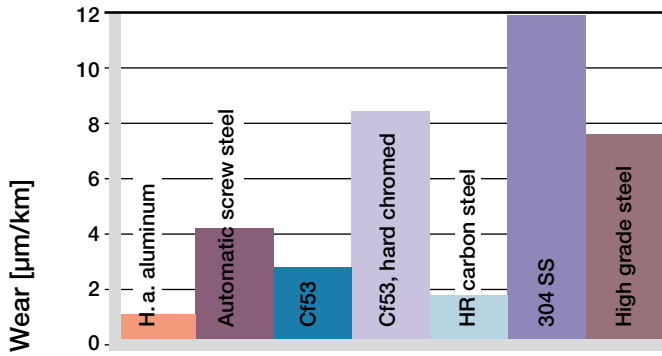

Graph 07: Wear, rotating with different shaft materials, pressure $p = 1 \text{ MPa}$, $v = 0.3 \text{ m/s}$

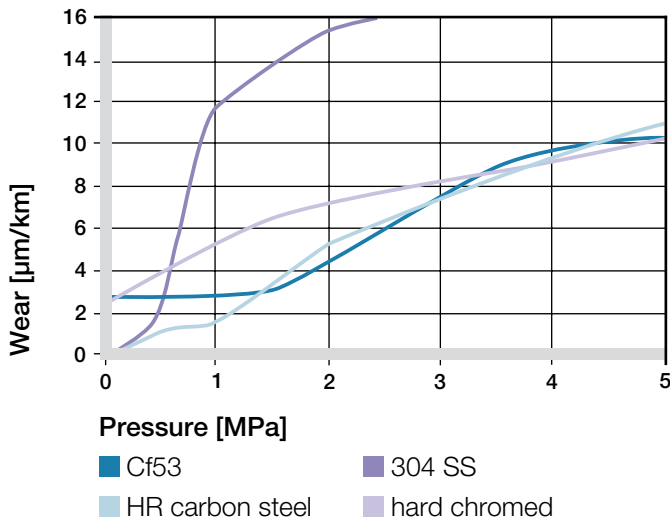

Graph 08: Wear with different shaft materials in rotational operation, as a function of the pressure

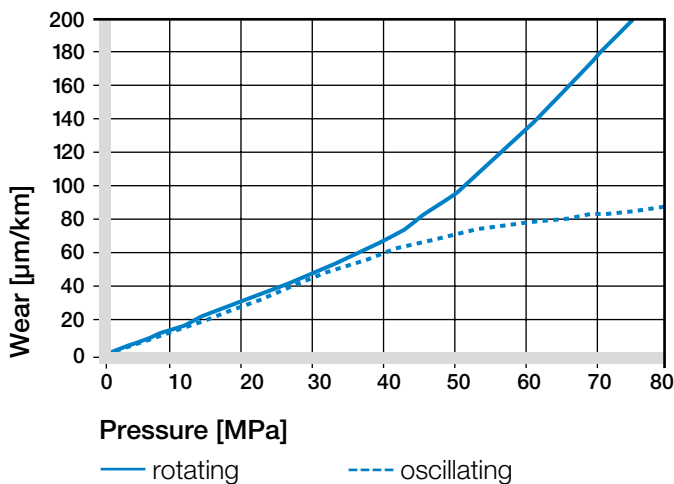

Graph 09: Wear for oscillating and rotating applications with shaft material Cf53 hardened and ground steel, as a function of the pressure

iglidur® G	Dry	Greases	Oil	Water
C.o.f. μ	0.08–0.15	0.09	0.04	0.04

Table 04: Coefficient of friction against steel ($R_a = 1 \text{ }\mu\text{m}$, 50 HRC)

Additional Properties

Chemical Resistance

iglidur® G plain bearings have strong resistance to chemicals. They are also resistant to most lubricants.

iglidur® G plain bearings are not attacked by most weak organic or inorganic acids.

► Chemical Table, page 1118

Medium	Resistance
Alcohol	+ to 0
Hydrocarbons	+
Greases, oils without additives	+
Fuels	+
Diluted acids	0 to –
Strong acids	–
Diluted alkalines	+
Strong alkalines	0

+ resistant 0 conditionally resistant – not resistant

All data given at room temperature [$+20 \text{ }^\circ\text{C}$]

Table 05: Chemical resistance

Radiation Resistance

Plain bearings made of iglidur® G are resistant to radiation up to an intensity of $3 \cdot 10^2 \text{ Gy}$.

UV Resistance

iglidur® G plain bearings are permanently resistant to UV radiation.

Vacuum

iglidur® G plain bearings outgas in a vacuum. Use in a vacuum environment is only possible with dehumidified bearings.

Electrical Properties

iglidur® G plain bearings are electrically insulating.

Volume resistance	$> 10^{13} \text{ }\Omega\text{cm}$
Surface resistance	$> 10^{11} \text{ }\Omega$

Moisture Absorption

The moisture absorption of iglidur® G plain bearings is approximately 0,7 % in standard atmosphere. The saturation limit submerged in water is 4 %. This must be taken into account for these types of applications.

Maximum moisture absorption

At +23 °C/50 % r.h. 0.7 % weight

Max. water absorption 4.0 % weight

Table 06: Moisture absorption

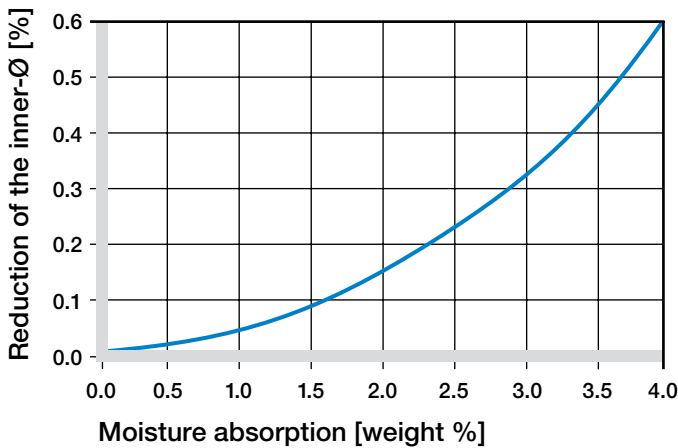

Graph 10: Effect of moisture absorption on plain bearings

Installation Tolerances

iglidur® G plain bearings are standard bearings for shafts with h-tolerance (recommended minimum h9). The bearings are designed for pressfit into a housing machined to a H7 tolerance. After being assembled into a nominal size housing, in standard cases the inner diameter automatically adjusts to the E10 tolerances. For particular dimensions the tolerance differs depending on the wall thickness (please see product range table).

► Testing Methods, page 59

Diameter d1 [mm]	Shaft h9 [mm]	iglidur® G E10 [mm]	Housing H7 [mm]
up to 3	0-0.025	+0.014 +0.054	0 +0.010
> 3 to 6	0-0.030	+0.020 +0.068	0 +0.012
> 6 to 10	0-0.036	+0.025 +0.083	0 +0.015
> 10 to 18	0-0.043	+0.032 +0.102	0 +0.018
> 18 to 30	0-0.052	+0.040 +0.124	0 +0.021
> 30 to 50	0-0.062	+0.050 +0.150	0 +0.025
> 50 to 80	0-0.074	+0.060 +0.180	0 +0.030
> 80 to 120	0-0.087	+0.072 +0.212	0 +0.035
> 120 to 180	0-0.100	+0.085 +0.245	0 +0.040

Table 07: Important tolerances for plain bearings according to ISO 3547-1 after pressfit

iglidur® G | Product Range

Sleeve Bearing

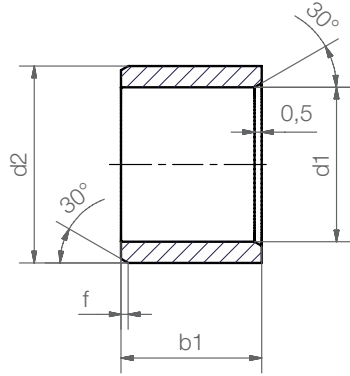

Order key

GSM-0103-02

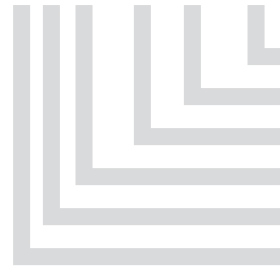

- Length b1
- Outer diameter d2
- Inner diameter d1
- Metric
- Type (Form S)
- Material iglidur® G

Dimensions according to ISO 3547-1 and special dimensions

Chamfer in relation to the d1

d1 [mm]:	Ø 1-6	Ø 6-12	Ø 12-30	Ø > 30
f [mm]:	0.3	0.5	0.8	1.2

Dimensions [mm]

Part number	d1	d1-Tolerance*	d2	b1 h13
GSM-0103-02	1.5	+0.014 +0.054	3.0	2.0
GSM-0203-03	2.0	+0.014 +0.054	3.5	3.0
GSM-02504-05	2.5	+0.014 +0.054	4.5	5.0
GSM-0304-03	3.0	+0.014 +0.054	4.5	3.0
GSM-0304-05	3.0	+0.014 +0.054	4.5	5.0
GSM-0304-06	3.0	+0.014 +0.054	4.5	6.0
GSM-0405-04	4.0	+0.020 +0.068	5.5	4.0
GSM-0405-06	4.0	+0.020 +0.068	5.5	6.0
GSM-0406-08	4.5	+0.020 +0.068	6.0	8.0
GSM-0407-05	4.0	+0.020 +0.068	7.0	5.5
GSM-0506-046	5.0	+0.010 +0.040	6.0	4.6
GSM-0506-05	5.0	+0.010 +0.040	6.0	5.0
GSM-0506-07	5.0	+0.010 +0.040	6.0	7.0
GSM-0507-05	5.0	+0.020 +0.068	7.0	5.0
GSM-0507-07	5.0	+0.020 +0.068	7.0	7.0
GSM-0507-08	5.0	+0.020 +0.068	7.0	8.0
GSM-0507-10	5.0	+0.020 +0.068	7.0	10.0
GSM-0607-06	6.0	+0.010 +0.040	7.0	6.0
GSM-0607-12	6.0	+0.010 +0.040	7.0	12.0
GSM-0607-17	6.0	+0.010 +0.040	7.0	17.0
GSM-0607-17.5	6.0	+0.010 +0.040	7.0	17.5
GSM-0607-19	6.0	+0.010 +0.040	7.0	19.0
GSM-0608-015	6.0	+0.020 +0.068	8.0	1.5
GSM-0608-025	6.0	+0.020 +0.068	8.0	2.5
GSM-0608-03	6.0	+0.020 +0.068	8.0	3.0

Part number	d1	d1-Tolerance*	d2	b1 h13
GSM-0608-04	6.0	+0.020 +0.068	8.0	4.0
GSM-0608-05	6.0	+0.020 +0.068	8.0	5.0
GSM-0608-055	6.0	+0.020 +0.068	8.0	5.5
GSM-0608-06	6.0	+0.020 +0.068	8.0	6.0
GSM-0608-08	6.0	+0.020 +0.068	8.0	8.0
GSM-0608-09	6.0	+0.020 +0.068	8.0	9.5
GSM-0608-10	6.0	+0.020 +0.068	8.0	10.0
GSM-0608-11	6.0	+0.020 +0.068	8.0	11.8
GSM-0608-13	6.0	+0.020 +0.068	8.0	13.8
GSM-0708-10	7.0	+0.013 +0.049	8.0	10.0
GSM-0708-19	7.0	+0.013 +0.049	8.0	19.0
GSM-0709-08	7.0	+0.025 +0.083	9.0	8.0
GSM-0709-09	7.0	+0.025 +0.083	9.0	9.0
GSM-0709-10	7.0	+0.025 +0.083	9.0	10.0
GSM-0709-12	7.0	+0.025 +0.083	9.0	12.0
GSM-0809-05	8.0	+0.013 +0.049	9.0	5.0
GSM-0809-06	8.0	+0.013 +0.049	9.0	6.0
GSM-0809-08	8.0	+0.013 +0.049	9.0	8.0
GSM-0809-12	8.0	+0.013 +0.049	9.0	12.0
GSM-0810-05	8.0	+0.025 +0.083	10.0	5.0
GSM-0810-06	8.0	+0.025 +0.083	10.0	6.0
GSM-0810-07	8.0	+0.025 +0.083	10.0	6.8
GSM-0810-08	8.0	+0.025 +0.083	10.0	8.0
GSM-0810-10	8.0	+0.025 +0.083	10.0	10.0
GSM-0810-12	8.0	+0.025 +0.083	10.0	12.0

* after pressfit. Testing methods ► page 59



delivery from stock
time



prices price list online
www.igus.eu/eu/g



Sleeve Bearing

Dimensions [mm]

Part number	d1	d1-Tolerance*	d2	b1 h13
GSM-0810-13	8.0	+0.025 +0.083	10.0	13.8
GSM-0810-15	8.0	+0.025 +0.083	10.0	15.0
GSM-0810-16	8.0	+0.025 +0.083	10.0	16.0
GSM-0810-20	8.0	+0.025 +0.083	10.0	20.0
GSM-0810-22	8.0	+0.025 +0.083	10.0	22.0
GSM-0810-25	8.0	+0.025 +0.083	10.1	25.0
GSM-0812-09	8.0	+0.040 +0.130	12.0	9.0
GSM-0910-12	9.0	+0.013 +0.049	10.0	12.0
GSM-0910-16	9.0	+0.013 +0.049	10.0	16.0
GSM-0911-06	9.0	+0.025 +0.083	11.0	6.0
GSM-0911-20	9.0	+0.025 +0.083	11.0	20.0
GSM-1011-06	10.0	+0.013 +0.049	11.0	6.0
GSM-1011-07	10.0	+0.013 +0.049	11.0	7.0
GSM-1011-10	10.0	+0.013 +0.049	11.0	10.0
GSM-1011-20	10.0	+0.013 +0.049	11.0	20.0
GSM-1011-25	10.0	+0.013 +0.049	11.0	25.0
GSM-1011-30	10.0	+0.013 +0.049	11.0	30.0
GSM-1012-04	10.0	+0.025 +0.083	12.0	4.0
GSM-1012-045	10.0	+0.025 +0.083	12.0	4.5
GSM-1012-05	10.0	+0.025 +0.083	12.0	5.0
GSM-1012-06	10.0	+0.025 +0.083	12.0	6.0
GSM-1012-07	10.0	+0.025 +0.083	12.0	7.0
GSM-1012-08	10.0	+0.025 +0.083	12.0	8.0
GSM-1012-09	10.0	+0.025 +0.083	12.0	9.0
GSM-1012-10	10.0	+0.025 +0.083	12.0	10.0
GSM-1012-12	10.0	+0.025 +0.083	12.0	12.0
GSM-1012-14	10.0	+0.025 +0.083	12.0	14.0
GSM-1012-15	10.0	+0.025 +0.083	12.0	15.0
GSM-1012-17	10.0	+0.025 +0.083	12.0	17.0
GSM-1012-20	10.0	+0.025 +0.083	12.0	20.0
GSM-1013-13	10.0	+0.025 +0.083	13.0	13.5
GSM-1014-10	10.0	+0.025 +0.115	14.0	10.0
GSM-1014-20	10.0	+0.025 +0.115	14.0	20.0
GSM-1016-10	10.0	+0.040 +0.130	16.0	10.0
GSM-1213-047	12.0	+0.016 +0.059	13.0	4.7
GSM-1213-10	12.0	+0.016 +0.059	13.0	10.0
GSM-1213-12	12.0	+0.016 +0.059	13.0	12.0
GSM-1213-15	12.0	+0.016 +0.059	13.0	15.0
GSM-1214-04	12.0	+0.032 +0.102	14.0	4.0
GSM-1214-05	12.0	+0.032 +0.102	14.0	5.0
GSM-1214-06	12.0	+0.032 +0.102	14.0	6.0
GSM-1214-08	12.0	+0.032 +0.102	14.0	8.0

Part number	d1	d1-Tolerance*	d2	b1 h13
GSM-1214-10	12.0	+0.032 +0.102	14.0	10.0
GSM-1214-12	12.0	+0.032 +0.102	14.0	12.0
GSM-1214-14	12.0	+0.032 +0.102	14.0	14.0
GSM-1214-15	12.0	+0.032 +0.102	14.0	15.0
GSM-1214-20	12.0	+0.032 +0.102	14.0	20.0
GSM-1214-25	12.0	+0.032 +0.102	14.0	25.0
GSM-1215-06	12.0	+0.032 +0.102	15.0	6.0
GSM-1215-22	12.0	+0.032 +0.102	15.0	22.0
GSM-1216-10	12.0	+0.050 +0.160	16.0	10.0
GSM-1216-20	12.0	+0.050 +0.160	16.0	20.0
GSM-1315-070	13.0	+0.032 +0.102	15.0	7.0
GSM-1315-075	13.0	+0.032 +0.102	15.0	7.5
GSM-1315-10	13.0	+0.032 +0.102	15.0	10.0
GSM-1315-15	13.0	+0.032 +0.102	15.0	15.0
GSM-1315-20	13.0	+0.032 +0.102	15.0	20.0
GSM-1315-25	13.0	+0.032 +0.102	15.0	25.0
GSM-1416-03	14.0	+0.032 +0.102	16.0	3.0
GSM-1416-06	14.0	+0.032 +0.102	16.0	6.0
GSM-1416-08	14.0	+0.032 +0.102	16.0	8.0
GSM-1416-10	14.0	+0.032 +0.102	16.0	10.0
GSM-1416-12	14.0	+0.032 +0.102	16.0	12.0
GSM-1416-15	14.0	+0.032 +0.102	16.0	15.0
GSM-1416-20	14.0	+0.032 +0.102	16.0	20.0
GSM-1416-25	14.0	+0.032 +0.102	16.0	25.0
GSM-1416-45	14.0	+0.032 +0.102	16.0	45.0
GSM-1516-10	15.0	+0.016 +0.059	16.0	10.0
GSM-1516-15	15.0	+0.016 +0.059	16.0	15.0
GSM-1517-04	15.0	+0.032 +0.102	17.0	4.0
GSM-1517-10	15.0	+0.032 +0.102	17.0	10.0
GSM-1517-12	15.0	+0.032 +0.102	17.0	12.0
GSM-1517-15	15.0	+0.032 +0.102	17.0	15.0
GSM-1517-20	15.0	+0.032 +0.102	17.0	20.0
GSM-1517-25	15.0	+0.032 +0.102	17.0	25.0
GSM-1618-055	16.0	+0.032 +0.102	18.0	5.5
GSM-1618-08	16.0	+0.032 +0.102	18.0	8.0
GSM-1618-10	16.0	+0.032 +0.102	18.0	10.0
GSM-1618-12	16.0	+0.032 +0.102	18.0	12.0
GSM-1618-13.5	16.0	+0.032 +0.102	18.0	13.5
GSM-1618-15	16.0	+0.032 +0.102	18.0	15.0
GSM-1618-20	16.0	+0.032 +0.102	18.0	20.0
GSM-1618-25	16.0	+0.032 +0.102	18.0	25.0
GSM-1618-30	16.0	+0.032 +0.102	18.0	30.0

* after pressfit. Testing methods ► page 59

Dimensions [mm]

Part number	d1	d1-Tolerance*	d2	b1 h13
GSM-1618-50	16.0	+0.032 +0.102	18.0	50.0
GSM-1819-15	18.0	+0.016 +0.059	19.0	15.0
GSM-1820-06	18.0	+0.032 +0.102	20.0	6.0
GSM-1820-10	18.0	+0.032 +0.102	20.0	10.0
GSM-1820-12	18.0	+0.032 +0.102	20.0	12.0
GSM-1820-15	18.0	+0.032 +0.102	20.0	15.0
GSM-1820-20	18.0	+0.032 +0.102	20.0	20.0
GSM-1820-25	18.0	+0.032 +0.102	20.0	25.0
GSM-1820-34	18.0	+0.032 +0.102	20.0	34
GSM-1820-38	18.0	+0.032 +0.102	20.0	38
GSM-1820-45	18.0	+0.032 +0.102	20.0	45.0
GSM-1822-30	18.0	+0.032 +0.102	22.0	30.0
GSM-1922-06	19.0	+0.040 +0.124	22.0	6.0
GSM-1922-28	19.0	+0.040 +0.124	22.0	28.0
GSM-1922-35	19.0	+0.040 +0.124	22.0	35.0
GSM-2021-20	20.0	+0.020 +0.072	21.0	20.0
GSM-2022-03	20.0	+0.040 +0.124	22.0	3.0
GSM-2022-08	20.0	+0.040 +0.124	22.0	8.0
GSM-2022-105	20.0	+0.040 +0.124	22.0	10.5
GSM-2022-15	20.0	+0.040 +0.124	22.0	15.0
GSM-2022-20	20.0	+0.040 +0.124	22.0	20.0
GSM-2022-22	20.0	+0.040 +0.124	22.0	22.0
GSM-2022-28	20.0	+0.040 +0.124	22.0	28.0
GSM-2022-30	20.0	+0.040 +0.124	22.0	30.0
GSM-2022-47	20.0	+0.040 +0.124	22.0	47.0
GSM-2023-10	20.0	+0.040 +0.124	23.0	10.0
GSM-2023-15	20.0	+0.040 +0.124	23.0	15.0
GSM-2023-20	20.0	+0.040 +0.124	23.0	20.0
GSM-2023-23	20.0	+0.040 +0.124	23.0	23.0
GSM-2023-24	20.0	+0.040 +0.124	23.0	24.0
GSM-2023-25	20.0	+0.040 +0.124	23.0	25.0
GSM-2023-30	20.0	+0.040 +0.124	23.0	30.0
GSM-2023-35	20.0	+0.040 +0.124	23.0	35.0
GSM-2224-08	22.0	+0.040 +0.124	24.0	8.0
GSM-2224-10	22.0	+0.040 +0.124	24.0	10.0
GSM-2224-12	22.0	+0.040 +0.124	24.0	12.0
GSM-2224-15	22.0	+0.040 +0.124	24.0	15.0
GSM-2224-17	22.0	+0.040 +0.124	24.0	17.0
GSM-2224-20	22.0	+0.040 +0.124	24.0	20.0
GSM-2224-30	22.0	+0.040 +0.124	24.0	30.0
GSM-2224-48	22.0	+0.040 +0.124	24.0	48.0

Part number	d1	d1-Tolerance*	d2	b1 h13
GSM-2225-15	22.0	+0.040 +0.124	25.0	15.0
GSM-2225-20	22.0	+0.040 +0.124	25.0	20.0
GSM-2225-25	22.0	+0.040 +0.124	25.0	25.0
GSM-2225-30	22.0	+0.040 +0.124	25.0	30.0
GSM-2425-25	24.0	+0.020 +0.072	25.0	25.0
GSM-2427-06	24.0	+0.040 +0.124	27.0	6.0
GSM-2427-15	24.0	+0.040 +0.124	27.0	15.0
GSM-2427-20	24.0	+0.040 +0.124	27.0	20.0
GSM-2427-24	24.0	+0.040 +0.124	27.0	24.0
GSM-2427-25	24.0	+0.040 +0.124	27.0	25.0
GSM-2427-30	24.0	+0.040 +0.124	27.0	30.0
GSM-2526-23	25.0	+0.020 +0.072	26.0	23.0
GSM-2526-25	25.0	+0.020 +0.072	26.0	25.0
GSM-2528-12	25.0	+0.040 +0.124	28.0	12.0
GSM-2528-15	25.0	+0.040 +0.124	28.0	15.0
GSM-2528-20	25.0	+0.040 +0.124	28.0	20.0
GSM-2528-24	25.0	+0.040 +0.124	28.0	24.0
GSM-2528-25	25.0	+0.040 +0.124	28.0	25.0
GSM-2528-30	25.0	+0.040 +0.124	28.0	30.0
GSM-2528-35	25.0	+0.040 +0.124	28.0	35.0
GSM-2528-50	25.0	+0.040 +0.124	28.0	50.0
GSM-2630-16	26.0	+0.040 +0.124	30.0	16.0
GSM-2730-05	27.0	+0.040 +0.124	30.0	5.0
GSM-2832-105	28.0	+0.040 +0.124	32.0	10.5
GSM-2832-12	28.0	+0.040 +0.124	32.0	12.0
GSM-2832-15	28.0	+0.040 +0.124	32.0	15.0
GSM-2832-20	28.0	+0.040 +0.124	32.0	20.0
GSM-2832-23	28.0	+0.040 +0.124	32.0	23.0
GSM-2832-25	28.0	+0.040 +0.124	32.0	25.0
GSM-2832-30	28.0	+0.040 +0.124	32.0	30.0
GSM-2835-19	28.0	+0.065 +0.195	35.0	19.0
GSM-2835-28	28.0	+0.065 +0.195	35.0	28.0
GSM-2933-06	29.0	+0.040 +0.124	33.0	6.0
GSM-3031-05	30.0	+0.020 +0.072	31.0	5.0
GSM-3031-12	30.0	+0.020 +0.072	31.0	12.0
GSM-3031-30	30.0	+0.020 +0.072	31.0	30.0
GSM-3034-15	30.0	+0.040 +0.124	34.0	15.0
GSM-3034-20	30.0	+0.040 +0.124	34.0	20.0
GSM-3034-24	30.0	+0.040 +0.124	34.0	24.0
GSM-3034-25	30.0	+0.040 +0.124	34.0	25.0
GSM-3034-30	30.0	+0.040 +0.124	34.0	30.0

* after pressfit. Testing methods ► page 59

delivery from stock
time

prices price list online
www.igus.eu/eu/g



Sleeve Bearing

Dimensions [mm]

Part number	d1	d1-Tolerance*	d2	b1 h13
GSM-3034-35	30.0	+0.040 +0.124	34.0	35.0
GSM-3034-40	30.0	+0.040 +0.124	34.0	40.0
GSM-3034-525	30.0	+0.040 +0.124	34.0	52.5
GSM-3236-15	32.0	+0.050 +0.150	36.0	15.0
GSM-3236-20	32.0	+0.050 +0.150	36.0	20.0
GSM-3236-30	32.0	+0.050 +0.150	36.0	30.0
GSM-3236-40	32.0	+0.050 +0.150	36.0	40.0
GSM-3539-14	35.0	+0.050 +0.150	39.0	14.0
GSM-3539-20	35.0	+0.050 +0.150	39.0	20.0
GSM-3539-25	35.0	+0.050 +0.150	39.0	25.0
GSM-3539-30	35.0	+0.050 +0.150	39.0	30.0
GSM-3539-40	35.0	+0.050 +0.150	39.0	40.0
GSM-3539-50	35.0	+0.050 +0.150	39.0	50.0
GSM-3541-50	35.0	+0.050 +0.150	41.0	50.0
GSM-3640-20	36.0	+0.050 +0.150	40.0	20.0
GSM-3741-20	37.0	+0.050 +0.150	41.0	20.0
GSM-3842-25	38.0	+0.050 +0.150	42.0	25.0
GSM-4044-10	40.0	+0.050 +0.150	44.0	10.0
GSM-4044-16	40.0	+0.050 +0.150	44.0	16.5
GSM-4044-20	40.0	+0.050 +0.150	44.0	20.0
GSM-4044-30	40.0	+0.050 +0.150	44.0	30.0
GSM-4044-40	40.0	+0.050 +0.150	44.0	40.0
GSM-4044-50	40.0	+0.050 +0.150	44.0	50.0
GSM-4044-525	40.0	+0.050 +0.150	44.0	52.5
GSM-4246-40	42.0	+0.050 +0.150	46.0	40.0
GSM-4448-20	44.0	+0.050 +0.150	48.0	20.0
GSM-4550-22	45.0	+0.050 +0.150	50.0	22.0
GSM-4550-235	45.0	+0.050 +0.150	50.0	23.5
GSM-4550-30	45.0	+0.050 +0.150	50.0	30.0
GSM-4550-38	45.0	+0.050 +0.150	50.0	38.0
GSM-4550-40	45.0	+0.050 +0.150	50.0	40.0
GSM-4550-50	45.0	+0.050 +0.150	50.0	50.0
GSM-5055-20	50.0	+0.050 +0.150	55.0	20.0
GSM-5055-25	50.0	+0.050 +0.150	55.0	25.0
GSM-5055-30	50.0	+0.050 +0.150	55.0	30.0
GSM-5055-40	50.0	+0.050 +0.150	55.0	40.0
GSM-5055-50	50.0	+0.050 +0.150	55.0	50.0
GSM-5257-20	52.0	+0.060 +0.180	57.0	20.0

Part number	d1	d1-Tolerance*	d2	b1 h13
GSM-5560-20	55.0	+0.060 +0.180	60.0	20.0
GSM-5560-40	55.0	+0.060 +0.180	60.0	40.0
GSM-5560-50	55.0	+0.060 +0.180	60.0	50.0
GSM-5560-60	55.0	+0.060 +0.180	60.0	60.0
GSM-6065-30	60.0	+0.060 +0.180	65.0	30.0
GSM-6065-40	60.0	+0.060 +0.180	65.0	40.0
GSM-6065-50	60.0	+0.060 +0.180	65.0	50.0
GSM-6065-60	60.0	+0.060 +0.180	65.0	60.0
GSM-6065-70	60.0	+0.060 +0.180	65.0	70.0
GSM-6267-35	62.0	+0.100 +0.250	67.0	35.0
GSM-6267-72	62.0	+0.060 +0.180	67.0	72.0
GSM-6570-104	65.0	+0.060 +0.180	70.0	104.0
GSM-6570-30	65.0	+0.060 +0.180	70.0	30.0
GSM-6570-50	65.0	+0.060 +0.180	70.0	50.0
GSM-6873-60	68.0	+0.060 +0.180	73.0	60.0
GSM-7075-60	70.0	+0.060 +0.180	75.0	60.0
GSM-7277-245	72.0	+0.060 +0.180	77.0	24.5
GSM-7277-76	72.0	+0.060 +0.180	77.0	76.0
GSM-7580-40	75.0	+0.060 +0.180	80.0	40.0
GSM-7580-60	75.0	+0.060 +0.180	80.0	60.0
GSM-8085-60	80.0	+0.060 +0.180	85.0	60.0
GSM-8085-100	80.0	+0.060 +0.180	85.0	100.0
GSM-8590-100	85.0	+0.072 +0.212	90.0	100.0
GSM-9095-100	90.0	+0.072 +0.212	95.0	100.0
GSM-95100-100	95.0	+0.072 +0.212	100.0	100.0
GSM-100105-215	100.0	+0.072 +0.212	105.0	21.5
GSM-100105-30	100.0	+0.072 +0.212	105.0	30.0
GSM-100105-32	100.0	+0.072 +0.212	105.0	32.0
GSM-100105-100	100.0	+0.072 +0.212	105.0	100.0
GSM-110115-100	110.0	+0.072 +0.212	115.0	100.0
GSM-120125-100	120.0	+0.072 +0.212	125.0	100.0
GSM-125130-100	125.0	+0.085 +0.245	130.0	100.0
GSM-130135-100	130.0	+0.085 +0.245	135.0	100.0
GSM-135140-80	135.0	+0.085 +0.245	140.0	80.0
GSM-140145-100	140.0	+0.085 +0.245	145.0	100.0
GSM-140145-104	140.0	+0.085 +0.245	145.0	104.0
GSM-150155-100	150.0	+0.085 +0.245	155.0	100.0

* after pressfit. Testing methods ► page 59



Even more dimensions from stock

More than 300 dimensions are now available. Search online for your required bearing.

► www.igus.eu/igidur-specialbearings

iglidur® G | Product Range

Flange Bearing

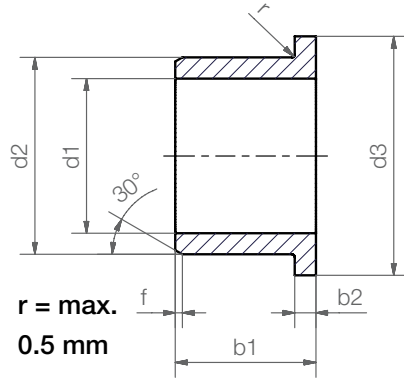

Order key

GFM-0304-02

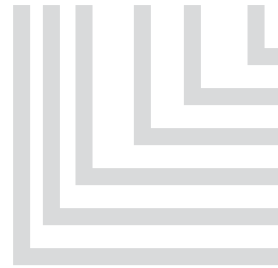

Length b1
Outer diameter d2
Inner diameter d1
Metric
Type (Form F)
Material iglidur® G

Dimensions according to ISO 3547-1 and special dimensions

Chamfer in relation to the d1

d1 [mm]:	Ø 1-6	Ø 6-12	Ø 12-30	Ø > 30
f [mm]:	0.3	0.5	0.8	1.2

Dimensions [mm]

Part number	d1	d1-Tolerance*	d2	d3 d13	b1	b2
					h13	-0.14
GFM-03040-15	3.0	+0.010 +0.040	4.0	7.5	15.0	0.5
GFM-0304-02	3.0	+0.014 +0.054	4.5	7.5	2.0	0.5
GFM-0304-0275	3.0	+0.014 +0.054	4.5	7.5	2.7	0.75
GFM-0304-03	3.0	+0.014 +0.054	4.5	7.5	3.0	0.75
GFM-0304-05	3.0	+0.014 +0.054	4.5	7.5	5.0	0.75
GFM-0304-15	3.0	+0.014 +0.054	4.5	7.5	15.0	0.75
GFM-030407-05	3.0	+0.014 +0.054	4.5	7.0	5.0	0.75
GFM-0405-03	4.0	+0.020 +0.068	5.5	9.5	3.0	0.75
GFM-0405-04	4.0	+0.020 +0.068	5.5	9.5	4.0	0.75
GFM-0405-06	4.0	+0.020 +0.068	5.5	9.5	6.0	0.75
GFM-0405-0255	4.0	+0.020 +0.068	5.5	9.5	2.5	0.75
GFM-04050-04	4.0	+0.010 +0.040	5.0	9.5	4.0	0.5
GFM-04050-06	4.0	+0.010 +0.040	5.0	9.5	6.0	0.5
GFM-040508-10	4.0	+0.020 +0.068	5.5	8.0	10.0	1.0
GFM-0506-035	5.0	+0.010 +0.040	6.0	10.0	3.5	0.5
GFM-0506-04	5.0	+0.010 +0.040	6.0	10.0	4.0	0.5
GFM-0506-05	5.0	+0.010 +0.040	6.0	10.0	5.0	0.5
GFM-0506-06	5.0	+0.010 +0.040	6.0	10.0	6.0	0.5
GFM-0506-15	5.0	+0.010 +0.040	6.0	10.0	15.3	0.5
GFM-0507-03	5.0	+0.020 +0.068	7.0	11.0	3.5	1.0
GFM-0507-04	5.0	+0.020 +0.068	7.0	11.0	4.0	1.0
GFM-0507-05	5.0	+0.020 +0.068	7.0	11.0	5.0	1.0
GFM-0507-07	5.0	+0.020 +0.068	7.0	11.0	7.0	1.0
GFM-0507-11	5.0	+0.020 +0.068	7.0	11.0	11.0	1.0
GFM-0507-145	5.0	+0.020 +0.068	7.0	11.0	14.5	1.0

* after pressfit. Testing methods ► page 59



delivery from stock
time



prices price list online
www.igus.eu/eu/g



Flange Bearing

Dimensions [mm]

Part number	d1	d1-Tolerance*	d2	d3 d13	b1 h13	b2 -0.14
GFM-0507-30	5.0	+0.020 +0.068	7.0	11.0	5.0	1.0
GFM-050709-05	5.0	+0.020 +0.068	7.0	9.5	5.0	1.0
GFM-050715-04	5.0	+0.020 +0.068	7.0	15.0	4.0	1.0
GFM-0607-024	6.0	+0.010 +0.040	7.0	11.0	2.4	0.5
GFM-0607-029	6.0	+0.010 +0.040	7.0	11.0	2.9	0.5
GFM-0607-045	6.0	+0.010 +0.040	7.0	11.0	4.5	0.5
GFM-0607-055	6.0	+0.010 +0.040	7.0	11.0	5.5	0.5
GFM-0607-06	6.0	+0.010 +0.040	7.0	11.0	6.0	0.5
GFM-0607-08	6.0	+0.010 +0.040	7.0	11.0	8.0	0.5
GFM-0607-10	6.0	+0.010 +0.040	7.0	11.0	10.0	0.5
GFM-060709-045	6.0	+0.010 +0.040	7.0	9.0	4.5	0.5
GFM-060709-10	6.0	+0.010 +0.040	7.0	9.0	10.0	0.5
GFM-0608-025	6.0	+0.020 +0.068	8.0	12.0	2.5	1.0
GFM-0608-04	6.0	+0.020 +0.068	8.0	12.0	4.0	1.0
GFM-0608-048	6.0	+0.020 +0.068	8.0	12.0	4.8	1.0
GFM-0608-05	6.0	+0.020 +0.068	8.0	12.0	5.0	1.0
GFM-0608-06	6.0	+0.020 +0.068	8.0	12.0	6.0	1.0
GFM-0608-07	6.0	+0.020 +0.068	8.0	12.0	7.0	1.0
GFM-0608-08	6.0	+0.020 +0.068	8.0	12.0	8.0	1.0
GFM-0608-10	6.0	+0.020 +0.068	8.0	12.0	10.0	1.0
GFM-0608-25	6.0	+0.020 +0.068	8.0	12.0	25.0	1.0
GFM-0608-35	6.0	+0.020 +0.068	8.0	12.0	35.0	1.0
GFM-060810-08	6.0	+0.020 +0.068	8.0	10.0	8.0	1.0
GFM-060814-028	6.0	+0.020 +0.068	8.0	14.0	2.8	1.0
GFM-060814-12	6.0	+0.020 +0.068	8.0	14.0	12.0	1.0
GFM-0708-017	7.0	+0.013 +0.049	8.0	12.0	1.7	0.5
GFM-0708-03	7.0	+0.013 +0.049	8.0	12.0	3.0	0.5
GFM-0708-08	7.0	+0.013 +0.049	8.0	12.0	8.0	0.5
GFM-0709-06	7.0	+0.025 +0.083	9.0	15.0	6.0	1.0
GFM-0709-10	7.0	+0.025 +0.083	9.0	15.0	10.0	1.0
GFM-0709-12	7.0	+0.025 +0.083	9.0	15.0	12.0	1.0
GFM-0709-035	7.0	+0.025 +0.083	9.0	15.0	3.5	1.0
GFM-070919-10	7.0	+0.025 +0.083	9.0	19.0	10.0	1.0
GFM-0809-03	8.0	+0.013 +0.049	9.0	15.0	3.0	0.5
GFM-0809-035	8.0	+0.013 +0.049	9.0	13.0	3.5	0.5
GFM-0809-055	8.0	+0.013 +0.049	9.0	13.0	5.5	0.5
GFM-0809-08	8.0	+0.013 +0.049	9.0	13.0	8.0	0.5
GFM-0809-12	8.0	+0.013 +0.049	9.0	13.0	12.0	0.5
GFM-0810-03	8.0	+0.025 +0.083	10.0	15.0	3.0	1.0
GFM-0810-11	8.0	+0.025 +0.083	10.0	14.0	11.0	1.0
GFM-0810-035	8.0	+0.025 +0.083	10.0	15.0	3.5	1.0
GFM-0810-04	8.0	+0.025 +0.083	10.0	15.0	4.0	1.0

* after pressfit. Testing methods ► page 59

Dimensions [mm]

Part number	d1	d1-Tolerance*	d2	d3 d13	b1 h13	b2 -0.14
GFM-0810-050	8.0	+0.025 +0.083	10.0	15.0	5.0	1.0
GFM-0810-05	8.0	+0.025 +0.083	10.0	15.0	5.5	1.0
GFM-0810-065	8.0	+0.025 +0.083	10.0	15.0	6.5	1.0
GFM-0810-07	8.0	+0.025 +0.083	10.0	15.0	7.5	1.0
GFM-0810-09	8.0	+0.025 +0.083	10.0	15.0	9.5	1.0
GFM-0810-10	8.0	+0.025 +0.083	10.0	14.0	10.0	1.0
GFM-0810-15	8.0	+0.025 +0.083	10.0	15.0	15.0	1.0
GFM-0810-25	8.0	+0.025 +0.083	10.0	15.0	25.0	1.0
GFM-0810-30	8.0	+0.025 +0.083	10.0	15.0	30.0	1.0
GFM-081012-125	8.0	+0.025 +0.083	10.0	12.0	12.5	1.0
GFM-081013-08	8.0	+0.025 +0.083	10.0	13.0	8.0	1.0
GFM-081014-05	8.0	+0.040 +0.098	10.0	14.0	5.0	1.0
GFM-081014-06	8.0	+0.025 +0.083	10.0	14.0	6.0	1.0
GFM-081014-08	8.0	+0.025 +0.083	10.0	14.0	8.0	1.0
GFM-081014-10	8.0	+0.040 +0.098	10.0	14.0	10.0	1.0
GFM-081016-11	8.0	+0.025 +0.083	10.0	16.0	11.5	1.5
GFM-081016-15	8.0	+0.025 +0.083	10.0	16.0	15.5	1.5
GFM-081017-15	8.0	+0.025 +0.083	10.0	17.0	15.0	1.0
GFM-081018-03	8.0	+0.025 +0.083	10.0	18.0	3.0	1.0
GFM-0812-06	8.0	+0.040 +0.130	12.0	16.0	6.0	2.0
GFM-081221-08	8.0	+0.040 +0.130	12.0	21.0	8.0	2.0
GFM-0910-065	9.0	+0.013 +0.049	10.0	15.0	6.5	0.5
GFM-0910-17	9.0	+0.013 +0.049	10.0	15.0	17.5	0.5
GFM-1011-03	10.0	+0.013 +0.046	11.0	20.0	3.5	0.5
GFM-1011-044	10.0	+0.013 +0.049	11.0	15.0	4.4	0.5
GFM-1011-10	10.0	+0.013 +0.049	11.0	15.0	10.0	0.5
GFM-1012-035	10.0	+0.025 +0.083	12.0	18.0	3.5	1.0
GFM-1012-04	10.0	+0.025 +0.083	12.0	18.0	4.0	1.0
GFM-1012-05	10.0	+0.025 +0.083	12.0	18.0	5.0	1.0
GFM-1012-06	10.0	+0.025 +0.083	12.0	18.0	6.0	1.0
GFM-1012-07	10.0	+0.025 +0.083	12.0	18.0	7.0	1.0
GFM-1012-09	10.0	+0.025 +0.083	12.0	18.0	9.0	1.0
GFM-1012-10	10.0	+0.025 +0.083	12.0	18.0	10.0	1.0
GFM-1012-12	10.0	+0.025 +0.083	12.0	18.0	12.0	1.0
GFM-1012-15	10.0	+0.025 +0.083	12.0	18.0	15.0	1.0
GFM-1012-17	10.0	+0.025 +0.083	12.0	18.0	17.0	1.0
GFM-101214-07	10.0	+0.025 +0.083	12.0	14.0	7.0	1.0
GFM-101215-12	10.0	+0.025 +0.083	12.0	15.0	12.0	1.0
GFM-101216-06	10.0	+0.025 +0.083	12.0	16.0	6.0	1.0
GFM-101216-09	10.0	+0.025 +0.083	12.0	16.0	9.0	1.0
GFM-101216-15	10.0	+0.025 +0.083	12.0	16.0	15.0	1.0
GFM-1112-06	11.0	+0.016 +0.059	12.0	16.0	6.0	0.5

* after pressfit. Testing methods ► page 59

delivery from stock
time

prices price list online
www.igus.eu/eu/g



Flange Bearing

Dimensions [mm]

Part number	d1	d1-Tolerance*	d2	d3 d13	b1 h13	b2 -0.14
GFM-1213-03	12.0	+0.016 +0.059	13.0	17.0	3.0	0.5
GFM-121315-12	12.0	+0.016 +0.059	13.0	15.0	12.0	0.5
GFM-1213-12	12.0	+0.016 +0.059	13.0	17.0	12.0	0.5
GFM-1214-03	12.0	+0.032 +0.102	14.0	20.0	3.0	1.0
GFM-1214-05	12.0	+0.032 +0.102	14.0	20.0	5.0	1.0
GFM-1214-06	12.0	+0.032 +0.102	14.0	20.0	6.0	1.0
GFM-1214-07	12.0	+0.032 +0.102	14.0	20.0	7.0	1.0
GFM-1214-09	12.0	+0.032 +0.102	14.0	20.0	9.0	1.0
GFM-1214-10	12.0	+0.032 +0.102	14.0	20.0	10.0	1.0
GFM-1214-11	12.0	+0.032 +0.102	14.0	20.0	11.0	1.0
GFM-1214-12	12.0	+0.032 +0.102	14.0	20.0	12.0	1.0
GFM-1214-15	12.0	+0.032 +0.102	14.0	20.0	15.0	1.0
GFM-1214-17	12.0	+0.032 +0.102	14.0	20.0	17.0	1.0
GFM-1214-20	12.0	+0.032 +0.102	14.0	20.0	20.0	1.0
GFM-1214-24	12.0	+0.032 +0.102	14.0	20.0	24.0	1.0
GFM-1214-31	12.0	+0.032 +0.102	14.0	20.0	31.0	1.0
GFM-1214-40	12.0	+0.032 +0.102	14.0	20.0	40.0	1.0
GFM-121418-04	12.0	+0.032 +0.102	14.0	18.0	4.0	1.0
GFM-121418-08	12.0	+0.032 +0.102	14.0	18.0	8.0	1.0
GFM-121418-10	12.0	+0.032 +0.102	14.0	18.0	10.0	1.0
GFM-121418-12	12.0	+0.032 +0.102	14.0	18.0	12.0	1.0
GFM-121418-15	12.0	+0.032 +0.102	14.0	18.0	15.0	1.0
GFM-121418-20	12.0	+0.032 +0.102	14.0	18.0	20.0	1.0
GFM-1315-06	13.0	+0.032 +0.102	15.0	22.0	6.0	1.0
GFM-1315-08	13.0	+0.032 +0.102	15.0	22.0	8.0	1.0
GFM-1416-03	14.0	+0.032 +0.102	16.0	22.0	3.0	1.0
GFM-1416-04	14.0	+0.032 +0.102	16.0	22.0	4.0	1.0
GFM-1416-06	14.0	+0.032 +0.102	16.0	22.0	6.0	1.0
GFM-1416-08	14.0	+0.032 +0.102	16.0	22.0	8.0	1.0
GFM-1416-10	14.0	+0.032 +0.102	16.0	22.0	10.0	1.0
GFM-1416-12	14.0	+0.032 +0.102	16.0	22.0	12.0	1.0
GFM-1416-17	14.0	+0.032 +0.102	16.0	22.0	17.0	1.0
GFM-1416-21	14.0	+0.032 +0.102	16.0	22.0	21.0	1.0
GFM-1516-02	15.0	+0.016 +0.059	16.0	20.0	2.0	0.5
GFM-1516-025	15.0	+0.016 +0.059	16.0	20.0	2.5	0.5
GFM-1516-03	15.0	+0.016 +0.059	16.0	20.0	3.0	0.5
GFM-1516-15	15.0	+0.016 +0.059	16.0	20.0	15.0	0.5
GFM-1517-04	15.0	+0.032 +0.102	17.0	23.0	4.0	1.0
GFM-1517-045	15.0	+0.032 +0.102	17.0	23.0	4.5	1.0
GFM-1517-05	15.0	+0.032 +0.102	17.0	23.0	5.0	1.0
GFM-1517-09	15.0	+0.032 +0.102	17.0	23.0	9.0	1.0
GFM-1517-12	15.0	+0.032 +0.102	17.0	23.0	12.0	1.0

* after pressfit. Testing methods ► page 59

Dimensions [mm]

Part number	d1	d1-Tolerance*	d2	d3 d13	b1 h13	b2 -0.14
GFM-1517-17	15.0	+0.032 +0.102	17.0	23.0	17.0	1.0
GFM-1517-20	15.0	+0.032 +0.102	17.0	23.0	20.0	1.0
GFM-151824-32	15.0	+0.032 +0.102	18.0	24.0	32.0	1.5
GFM-1618-04	16.0	+0.032 +0.102	18.0	24.0	4.0	1.0
GFM-1618-05	16.0	+0.032 +0.102	18.0	24.0	5.0	1.0
GFM-1618-06	16.0	+0.032 +0.102	18.0	24.0	6.0	1.0
GFM-1618-09	16.0	+0.032 +0.102	18.0	24.0	9.0	1.0
GFM-1618-12	16.0	+0.032 +0.102	18.0	24.0	12.0	1.0
GFM-1618-16	16.0	+0.032 +0.102	18.0	24.0	16.0	1.0
GFM-1618-17	16.0	+0.032 +0.102	18.0	24.0	17.0	1.0
GFM-1618-21	16.0	+0.032 +0.102	18.0	24.0	21.0	1.0
GFM-1719-09	17.0	+0.032 +0.102	19.0	25.0	9.0	1.0
GFM-1719-25	17.0	+0.032 +0.102	19.0	25.0	25.0	1.0
GFM-1820-04	18.0	+0.032 +0.102	20.0	26.0	4.0	1.0
GFM-1820-06	18.0	+0.032 +0.102	20.0	26.0	6.0	1.0
GFM-1820-09	18.0	+0.032 +0.102	20.0	26.0	9.0	1.0
GFM-1820-11	18.0	+0.032 +0.102	20.0	26.0	11.0	1.0
GFM-1820-12	18.0	+0.032 +0.102	20.0	26.0	12.0	1.0
GFM-1820-17	18.0	+0.032 +0.102	20.0	26.0	17.0	1.0
GFM-1820-22	18.0	+0.032 +0.102	20.0	26.0	22.0	1.0
GFM-1820-30	18.0	+0.032 +0.102	20.0	26.0	30.0	1.0
GFM-1820-32	18.0	+0.032 +0.102	20.0	26.0	32.0	1.0
GFM-182022-06	18.0	+0.032 +0.102	20.0	22.0	6.0	1.0
GFM-1822-28	18.0	+0.032 +0.102	22.0	26.0	28.0	2.0
GFM-2021-035	20.0	+0.020 +0.072	21.0	26.0	3.5	0.5
GFM-2021-15	20.0	+0.020 +0.072	21.0	25.0	15.0	0.5
GFM-2021-20	20.0	+0.020 +0.072	21.0	25.0	20.0	0.5
GFM-2023-07	20.0	+0.040 +0.124	23.0	30.0	7.0	1.5
GFM-2023-11	20.0	+0.040 +0.124	23.0	30.0	11.5	1.5
GFM-2023-16	20.0	+0.040 +0.124	23.0	30.0	16.5	1.5
GFM-2023-21	20.0	+0.040 +0.124	23.0	30.0	21.5	1.5
GFM-202326-07	20.0	+0.040 +0.124	23.0	26.0	7.0	1.5
GFM-202326-21	20.0	+0.040 +0.124	23.0	26.0	21.5	1.5
GFM-202328-15	20.0	+0.040 +0.124	23.0	28.0	15.0	1.5
GFM-202329-20	20.0	+0.040 +0.124	23.0	29.0	20.0	1.5
GFM-2224-25	22.0	+0.040 +0.124	24.0	30.0	25.0	1.0
GFM-222529-045	22.0	+0.040 +0.124	25.0	29.0	4.5	1.5
GFM-222535-315	22.0	+0.040 +0.124	25.0	35.0	31.5	1.5
GFM-2427-07	24.0	+0.040 +0.124	27.0	32.0	7.0	1.5
GFM-2427-10	24.0	+0.040 +0.124	27.0	32.0	10.0	1.5
GFM-2526-25	25.0	+0.020 +0.072	26.0	30.0	25.0	0.5
GFM-2527-07	25.0	+0.040 +0.124	27.0	32.0	7.0	1.0

* after pressfit. Testing methods ► page 59

delivery from stock
time

prices price list online
www.igus.eu/eu/g



Flange Bearing

Dimensions [mm]

Part number	d1	d1-Tolerance*	d2	d3 d13	b1 h13	b2 -0.14
GFM-2527-48	25.0	+0.040 +0.124	27.0	32.0	48.0	1.0
GFM-252830-10	25.0	+0.040 +0.124	28.0	30.0	10.0	1.5
GFM-2528-11	25.0	+0.040 +0.124	28.0	35.0	11.5	1.5
GFM-2528-16	25.0	+0.040 +0.124	28.0	35.0	16.5	1.5
GFM-2528-21	25.0	+0.040 +0.124	28.0	35.0	21.5	1.5
GFM-2630-12	26.0	+0.040 +0.124	30.0	37.0	12.0	2.0
GFM-2730-20	27.0	+0.040 +0.124	30.0	38.0	20.0	1.5
GFM-2830-10	28.0	+0.040 +0.124	30.0	36.0	10.0	1.0
GFM-2830-36	28.0	+0.040 +0.124	30.0	35.0	36.0	1.0
GFM-2830-48	28.0	+0.040 +0.124	30.0	35.0	48.0	1.0
GFM-283036-31	28.0	+0.040 +0.124	30.0	36.0	31.0	1.0
GFM-283239-20	28.0	+0.040 +0.124	32.0	39.0	20.0	2.0
GFM-283250-35	28.0	+0.040 +0.124	32.0	50.0	35.0	2.0
GFM-3031-20	30.0	+0.040 +0.124	31.0	36.0	20.0	0.5
GFM-3031-30	30.0	+0.040 +0.124	31.0	35.0	30.0	0.5
GFM-3032-04	30.0	+0.040 +0.124	32.0	37.0	4.0	1.0
GFM-3032-12	30.0	+0.040 +0.124	32.0	37.0	12.0	1.0
GFM-3032-17	30.0	+0.040 +0.124	32.0	37.0	17.5	1.0
GFM-3032-22	30.0	+0.040 +0.124	32.0	37.0	22.0	1.0
GFM-3034-09	30.0	+0.040 +0.124	34.0	42.0	9.0	2.0
GFM-3034-16	30.0	+0.040 +0.124	34.0	42.0	16.0	2.0
GFM-3034-20	30.0	+0.040 +0.124	34.0	42.0	20.0	2.0
GFM-3034-26	30.0	+0.040 +0.124	34.0	42.0	26.0	2.0
GFM-3034-37	30.0	+0.040 +0.124	34.0	42.0	37.0	2.0
GFM-303440-10	30.0	+0.040 +0.124	34.0	40.0	10.0	2.0
GFM-3236-16	32.0	+0.050 +0.150	36.0	40.0	16.0	2.0
GFM-3236-26	32.0	+0.050 +0.150	36.0	40.0	26.0	2.0
GFM-343850-35	34.0	+0.050 +0.150	38.0	50.0	35.0	2.0
GFM-3539-058	35.0	+0.050 +0.150	39.0	47.0	5.8	2.0
GFM-3539-07	35.0	+0.050 +0.150	39.0	47.0	7.0	2.0
GFM-3539-12	35.0	+0.050 +0.150	39.0	47.0	12.0	2.0
GFM-3539-16	35.0	+0.050 +0.150	39.0	47.0	16.0	2.0
GFM-3539-26	35.0	+0.050 +0.150	39.0	47.0	26.0	2.0
GFM-3539-36	35.0	+0.050 +0.150	39.0	47.0	36.0	2.0
GFM-3842-22	38.0	+0.050 +0.150	42.0	54.0	22.0	2.0
GFM-4044-07	40.0	+0.050 +0.150	44.0	52.0	7.0	2.0
GFM-4044-14	40.0	+0.050 +0.150	44.0	52.0	14.0	2.0
GFM-4044-20	40.0	+0.050 +0.150	44.0	52.0	20.0	2.0
GFM-4044-30	40.0	+0.050 +0.150	44.0	52.0	30.0	2.0
GFM-4044-40	40.0	+0.050 +0.150	44.0	52.0	40.0	2.0
GFM-4044-50	40.0	+0.050 +0.150	44.0	52.0	50.0	2.0
GFM-4046-20	40.0	+0.050 +0.150	46.0	50.0	20.0	2.0

* after pressfit. Testing methods ► page 59



Flange Bearing

Dimensions [mm]

Part number	d1	d1-Tolerance*	d2	d3 d13	b1 h13	b2 -0.14
GFM-4246-19	42.0	+0.050 +0.150	46.0	53.0	19.0	2.0
GFM-4550-25	45.0	+0.050 +0.150	50.0	58.0	25.0	2.0
GFM-4550-30	45.0	+0.050 +0.150	50.0	58.0	30.0	2.0
GFM-4550-50	45.0	+0.050 +0.150	50.0	58.0	50.0	2.0
GFM-5055-07	50.0	+0.050 +0.150	55.0	63.0	7.0	2.0
GFM-5055-10	50.0	+0.050 +0.150	55.0	63.0	10.0	2.0
GFM-5055-25	50.0	+0.050 +0.150	55.0	63.0	25.0	2.0
GFM-5055-40	50.0	+0.050 +0.150	55.0	63.0	40.0	2.0
GFM-5055-50	50.0	+0.050 +0.150	55.0	63.0	50.0	2.0
GFM-6065-07	60.0	+0.060 +0.180	65.0	73.0	7.0	2.0
GFM-6065-22	60.0	+0.060 +0.180	65.0	73.0	22.0	2.0
GFM-6065-30	60.0	+0.060 +0.180	65.0	73.0	30.0	2.0
GFM-6065-50	60.0	+0.060 +0.180	65.0	73.0	50.0	2.0
GFM-606580-62	60.0	+0.060 +0.180	65.0	80.0	62.0	2.0
GFM-6570-50	65.0	+0.060 +0.180	70.0	78.0	50.0	2.0
GFM-7075-50	70.0	+0.060 +0.180	75.0	83.0	50.0	2.0
GFM-7580-50	75.0	+0.060 +0.180	80.0	88.0	50.0	2.0
GFM-8085-50	80.0	+0.060 +0.180	85.0	93.0	50.0	2.5
GFM-8085-100	80.0	+0.060 +0.180	85.0	93.0	100.0	2.5
GFM-8590-100	85.0	+0.072 +0.212	90.0	98.0	100.0	2.5
GFM-9095-100	90.0	+0.072 +0.212	95.0	103.0	100.0	2.5
GFM-95100-100	95.0	+0.072 +0.212	100.0	108.0	100.0	2.5
GFM-100105-425	100.0	+0.072 +0.212	105.0	113.0	42.5	2.5
GFM-100105-100	100.0	+0.072 +0.212	105.0	113.0	100.0	2.5
GFM-110115-100	110.0	+0.072 +0.212	115.0	123.0	100.0	2.5
GFM-120125-80	120.0	+0.072 +0.212	125.0	133.0	80.0	2.5
GFM-120125-100	120.0	+0.072 +0.212	125.0	133.0	100.0	2.5
GFM-125130-100	125.0	+0.085 +0.245	130.0	138.0	100.0	2.5
GFM-130135-100	130.0	+0.085 +0.245	135.0	143.0	100.0	2.5
GFM-140145-100	140.0	+0.085 +0.245	145.0	153.0	100.0	2.5
GFM-150155-40	150.0	+0.085 +0.245	155.0	163.0	40.0	2.5
GFM-150155-100	150.0	+0.085 +0.245	155.0	163.0	100.0	2.5
GFM-195205240-65	195.0	+0.100 +0.285	205.0	240.0	65.0	5.0

* after pressfit. Testing methods ► page 59



Don't find your size?

Do you need another length, other dimensions or tolerances? You search a particular geometry or alternative for your application? Please call us. igus® takes in consideration your needs and provides you a solution in a very short time.



delivery from stock
time



prices price list online
www.igus.eu/eu/g

Thrust Washer

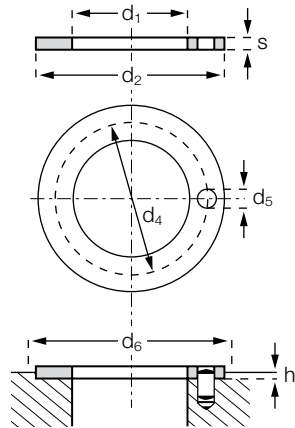

Order key

GTM-0509-006



Thickness s
Outer diameter d2
Inner diameter d1
Metric
Type (Form T)
Material iglidur® G

Dimensions according to ISO 3547-1 and special dimensions

Dimensions [mm]

Part number	d1	d2	s	d4	d5	h	d6
	+0.25	-0.25	-0.05	-0.12 +0.12	+0.375 +0.125	+0.2 -0.2	+0.12
GTM-0408-005	4.0	8.0	0.5	**	**	0.2	
GTM-0409-006	4.0	9.0	0.6	**	**	0.3	
GTM-0410-005	4.0	10.0	0.5	**	**	0.2	
GTM-0411-005	4.0	11.0	0.5 (-0.06)	**	**	0.2	
GTM-0509-006	5.0	9.5	0.6	**	**	0.3	9.5
GTM-0611-010	6.0	11.0	1.0	**	**	0.7	
GTM-0612-015	6.0	12.0	1.5	**	**	1.0	
GTM-0615-015	6.0	15.0	1.5	**	**	1.0	15
GTM-0620-015	6.0	20.0	1.5	13.0	1.5	1.0	20
GTM-0712-005	7.0	12.0	0.5	**	**	0.2	
GTM-0713-005	7.0	13.0	0.5	**	**	0.2	13
GTM-0815-005	8.0	15.0	0.5	**	**	0.2	15
GTM-0815-015	8.0	15.0	1.5	**	**	1.0	15
GTM-0818-010	8.0	18.0	1.0	**	**	0.7	18
GTM-0818-015	8.0	18.0	1.5	13.0	1.5	1.0	18
GTM-0818-020	8.0	18.0	2.0	**	**	1.5	
GTM-0913-010	9.0	13.0	1.0	**	**	0.7	
GTM-0918-015	9.0	18.0	1.5	13.5	1.5	1.0	18
GTM-1018-005	10.0	17.8	0.5	**	**	0.2	
GTM-1018-010	10.0	18.0	1.0	**	**	0.7	18
GTM-1018-015	10.0	18.0	1.5	**	**	1.0	
GTM-1018-020	10.0	18.0	2.0	**	**	1.5	18
GTM-1020-015	10.0	20.0	1.5	**	**	0.7	
GTM-1115-010	11.0	15.0	1.0	**	**	0.7	

** Design without fixing bore



delivery from stock
time



prices price list online
www.igus.eu/eu/g



Thrust Washer

Dimensions [mm]

Part number	d1	d2	s	d4	d5	h	d6
	+0.25	-0.25	-0.05	-0.12 +0.12	+0.375 +0.125	+0.2 -0.2	+0.12
GTM-1127-005	11.0	27.0	0.5	**	**	0.2	
GTM-1224-015	12.0	24.0	1.5	18.0	1.5	1.0	24
GTM-1230-015	12.0	30.0	1.5	**	**	1.0	
GTM-1420-015	14.0	20.0	1.5	**	**	1.0	20
GTM-1426-015	14.0	26.0	1.5	20.0	2.0	1.0	26
GTM-1522-008	15.0	22.0	0.8	**	**	0.5	22
GTM-1519-008	15.0	19.0	0.8	**	**	0.5	
GTM-1524-015	15.0	24.0	1.5	19.5	1.5	1.0	24
GTM-1524-0275	15.0	24.0	2.75	**	**	2.0	24
GTM-1628-010	16.0	28.0	1.0	**	**	0.7	
GTM-1630-015	16.0	30.0	1.5	22.0	2.0	1.0	30
GTM-1832-015	18.0	32.0	1.5	25.0	2.0	1.0	32
GTM-2036-015	20.0	36.0	1.5	28.0	3.0	1.0	36
GTM-2230-015	22.0	30.0	1.5	**	**	1.0	
GTM-2238-015	22.0	38.0	1.5	30.0	3.0	1.0	38
GTM-2442-015	24.0	42.0	1.5	33.0	3.0	1.0	42
GTM-2644-015	26.0	44.0	1.5	35.0	3.0	1.0	44
GTM-2835-005	28.5	35.8	0.5	**	**	0.2	35.8
GTM-2848-015	28.0	48.0	1.5	38.0	4.0	1.0	48
GTM-3246-010	32.0	45.8	1.0	**	**	0.7	
GTM-3254-015	32.0	54.0	1.5	43.0	4.0	1.0	54
GTM-3862-015	38.0	62.0	1.5	50.0	4.0	1.0	62
GTM-4266-015	42.0	66.0	1.5	54.0	4.0	1.0	66
GTM-4874-020	48.0	74.0	2.0	61.0	4.0	1.5	74
GTM-52569-020	52.5	69.0	2.0	**	**	1.5	
GTM-5278-020	52.0	78.0	2.0	65.0	4.0	1.5	78
GTM-6278-020	62.0	78.0	2.0	**	**	1.5	
GTM-6290-010	62.0	90.0	1.0	**	**	0.7	
GTM-6290-020	62.0	90.0	2.0	76.0	4.0	1.5	90
GTM-6881-020	68.0	81.0	2.0	**	**	1.5	81
GTM-78114-015	78.0	114.0	1.5	**	**	1.0	
GTM-80114-015	80.5	114.0	1.5	**	**	1.0	

** Design without fixing bore



Even more dimensions from stock

More than 300 dimensions are now available. Search online for your required bearing.

► www.igus.eu/iglidur-specialbearings

Sleeve Bearing

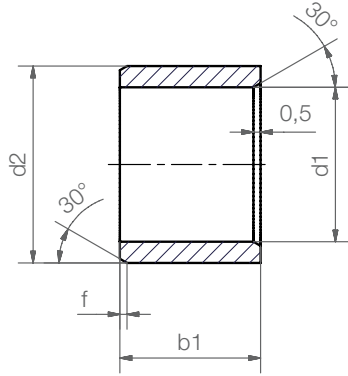

Order key

GSI-0203-03

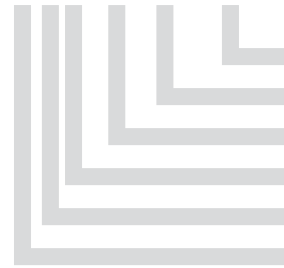

Length b1
Outer diameter d2
Inner diameter d1
Inch
Type (Form S)
Material iglidur® G

Chamfer in relation to the d1

d1 [Inch]:	Ø 0.040–0.236	Ø 0.236–0.472	Ø 0.472–1.18	Ø > 1.18
f [Inch]:	0.012	0.019	0.031	0.047

Dimensions [Inch]

Part number	d1	d2	b1	d1*		Housing Bore		Shaft Size	
				max.	min.	max.	min.	max.	min.
GSI-0203-03	1/8	3/16	3/16	.1269	.1251	.1878	.1873	.1243	.1236
GSI-0203-04	1/8	3/16	1/4	.1269	.1251	.1878	.1873	.1243	.1236
GSI-0203-06	1/8	3/16	3/8	.1269	.1251	.1878	.1873	.1243	.1236
GSI-0304-04	3/16	1/4	1/4	.1892	.1873	.2503	.2497	.1865	.1858
GSI-0304-06	3/16	1/4	3/8	.1892	.1873	.2503	.2497	.1865	.1858
GSI-0304-08	3/16	1/4	1/2	.1892	.1873	.2503	.2497	.1865	.1858
GSI-0405-04	1/4	5/16	1/4	.2521	.2498	.3128	.3122	.2490	.2481
GSI-0405-05	1/4	5/16	5/16	.2521	.2498	.3128	.3122	.2490	.2481
GSI-0405-06	1/4	5/16	3/8	.2521	.2498	.3128	.3122	.2490	.2481
GSI-0405-08	1/4	5/16	1/2	.2521	.2498	.3128	.3122	.2490	.2481
GSI-0405-10	1/4	5/16	5/8	.2521	.2498	.3128	.3122	.2490	.2481
GSI-0405-12	1/4	5/16	3/4	.2521	.2498	.3128	.3122	.2490	.2481
GSI-0506-04	5/16	3/8	1/4	.3148	.3125	.3753	.3747	.3115	.3106
GSI-0506-06	5/16	3/8	3/8	.3148	.3125	.3753	.3747	.3115	.3106
GSI-0506-08	5/16	3/8	1/2	.3148	.3125	.3753	.3747	.3115	.3106
GSI-0506-12	5/16	3/8	3/4	.3148	.3125	.3753	.3747	.3115	.3106
GSI-0607-04	3/8	15/32	1/4	.3773	.3750	.4691	.4684	.3740	.3731
GSI-0607-06	3/8	15/32	3/8	.3773	.3750	.4691	.4684	.3740	.3731
GSI-0607-08	3/8	15/32	1/2	.3773	.3750	.4691	.4684	.3740	.3731
GSI-0607-12	3/8	15/32	3/4	.3773	.3750	.4691	.4684	.3740	.3731
GSI-0608-08	3/8	8/16	1/2	.3783	.3760	.5015	.5010	.3750	.3741
GSI-0608-12	3/8	8/16	3/4	.3773	.3750	.5015	.5010	.3750	.3741
GSI-0708-04	7/16	17/32	1/4	.4406	.4379	.5316	.5309	.4365	.4355
GSI-0708-08	7/16	17/32	1/2	.4406	.4379	.5316	.5309	.4365	.4355
GSI-0809-03	1/2	19/32	3/16	.5030	.5003	.5941	.5934	.4990	.4980

* after pressfit. Testing methods ► page 59



delivery from stock
time



prices price list online
www.igus.eu/eu/g



Sleeve Bearing

Dimensions [Inch]

Part number	d1	d2	b1	d1*		Housing Bore		Shaft Size	
				max.	min.	max.	min.	max.	min.
GSI-0809-04	1/2	19/32	1/4	.5030	.5003	.5941	.5934	.4990	.4980
GSI-0809-06	1/2	19/32	3/8	.5030	.5003	.5941	.5934	.4990	.4980
GSI-0809-08	1/2	19/32	1/2	.5030	.5003	.5941	.5934	.4990	.4980
GSI-0809-10	1/2	19/32	5/8	.5030	.5003	.5941	.5934	.4990	.4980
GSI-0809-16	1/2	19/32	1	.5030	.5003	.5941	.5934	.4990	.4980
GSI-0810-08	1/2	5/8	1/2	.5040	.5013	.6260	.6250	.5000	.4990
GSI-0810-12	1/2	5/8	3/4	.5040	.5013	.6260	.6250	.5000	.4990
GSI-0910-06	9/16	21/32	3/8	.5655	.5627	.6566	.6559	.5615	.5605
GSI-0910-08	9/16	21/32	1/2	.5655	.5627	.6566	.6559	.5615	.5605
GSI-0910-10	9/16	21/32	5/8	.5655	.5627	.6566	.6559	.5615	.5605
GSI-1011-06	5/8	23/32	3/8	.6280	.6253	.7192	.7184	.6240	.6230
GSI-1011-08	5/8	23/32	1/2	.6280	.6253	.7192	.7184	.6240	.6230
GSI-1011-10	5/8	23/32	5/8	.6280	.6253	.7192	.7184	.6240	.6230
GSI-1011-12	5/8	23/32	3/4	.6280	.6253	.7192	.7184	.6240	.6230
GSI-1011-16	5/8	23/32	1	.6280	.6253	.7192	.7184	.6240	.6230
GSI-1011-20	5/8	23/32	1 1/4	.6280	.6253	.7192	.7184	.6240	.6230
GSI-1011-30	5/8	23/32	1 7/8	.6280	.6253	.7192	.7184	.6240	.6230
GSI-1012-08	5/8	3/4	1/2	.6290	.6263	.7510	.7500	.6250	.6240
GSI-1012-16	5/8	3/4	1	.6290	.6263	.7510	.7500	.6250	.6240
GSI-1112-14	11/16	25/32	7/8	.6906	.6879	.7817	.7809	.6865	.6855
GSI-1214-02	3/4	7/8	1/8	.7541	.7505	.8755	.8747	.7491	.7479
GSI-1214-06	3/4	7/8	3/8	.7541	.7505	.8755	.8747	.7491	.7479
GSI-1214-08	3/4	7/8	1/2	.7541	.7505	.8755	.8747	.7491	.7479
GSI-1214-12	3/4	7/8	3/4	.7541	.7505	.8755	.8747	.7491	.7479
GSI-1214-16	3/4	7/8	1	.7541	.7505	.8755	.8747	.7491	.7479
GSI-1214-20	3/4	7/8	1 1/4	.7541	.7505	.8755	.8747	.7491	.7479
GSI-1214-24	3/4	7/8	1 1/2	.7541	.7505	.8755	.8747	.7491	.7479
GSI-1416-06	7/8	1	3/8	.8791	.8757	1.0005	.9997	.8741	.8729
GSI-1416-08	7/8	1	1/2	.8791	.8757	1.0005	.9997	.8741	.8729
GSI-1416-10	7/8	1	5/8	.8791	.8757	1.0005	.9997	.8741	.8729
GSI-1416-12	7/8	1	3/4	.8791	.8757	1.0005	.9997	.8741	.8729
GSI-1416-16	7/8	1	1	.8791	.8757	1.0005	.9997	.8741	.8729
GSI-1416-24	7/8	1	1 1/2	.8791	.8757	1.0005	.9997	.8741	.8729
GSI-1618-08	1	1 1/8	1/2	1.0041	1.0007	1.1255	1.1247	.9991	.9979
GSI-1618-12	1	1 1/8	3/4	1.0041	1.0007	1.1255	1.1247	.9991	.9979
GSI-1618-16	1	1 1/8	1	1.0041	1.0007	1.1255	1.1247	.9991	.9979
GSI-1618-20	1	1 1/8	1 1/4	1.0041	1.0007	1.1255	1.1247	.9991	.9979
GSI-1618-24	1	1 1/8	1 1/2	1.0041	1.0007	1.1255	1.1247	.9991	.9979
GSI-1618-33	1	1 1/8	2 1/16	1.0041	1.0007	1.1255	1.1247	.9991	.9979
GSI-1820-12	1 1/8	1 9/32	3/4	1.1288	1.1254	1.2818	1.2808	1.1238	1.1226
GSI-1820-24	1 1/8	1 9/32	1 1/2	1.1288	1.1254	1.2818	1.2808	1.1238	1.1226
GSI-2022-12	1 1/4	1 13/32	3/4	1.2548	1.2508	1.4068	1.4058	1.2488	1.2472

* after pressfit. Testing methods ► page 59



Sleeve Bearing

Dimensions [Inch]

Part number	d1	d2	b1	d1*		Housing Bore		Shaft Size	
				max.	min.	max.	min.	max.	min.
GSI-2022-14	1 1/4	1 13/32	7/8	1.2548	1.2508	1.4068	1.4058	1.2488	1.2472
GSI-2022-16	1 1/4	1 13/32	1	1.2548	1.2508	1.4068	1.4058	1.2488	1.2472
GSI-2022-20	1 1/4	1 13/32	1 1/4	1.2548	1.2508	1.4068	1.4058	1.2488	1.2472
GSI-2022-24	1 1/4	1 13/32	1 1/2	1.2548	1.2508	1.4068	1.4058	1.2488	1.2472
GSI-2224-16	1 3/8	1 17/32	1	1.3798	1.3758	1.5318	1.5308	1.3738	1.3722
GSI-2224-24	1 3/8	1 17/32	1 1/2	1.3798	1.3758	1.5318	1.5308	1.3738	1.3722
GSI-2224-26	1 3/8	1 17/32	1 5/8	1.3798	1.3758	1.5318	1.5308	1.3738	1.3722
GSI-2426-06	1 1/2	1 21/32	3/8	1.5048	1.5008	1.6568	1.6558	1.4988	1.4972
GSI-2426-07	1 1/2	1 21/32	7/16	1.5048	1.5008	1.6568	1.6558	1.4988	1.4972
GSI-2426-08	1 1/2	1 21/32	1/2	1.5048	1.5008	1.6568	1.6558	1.4988	1.4972
GSI-2426-12	1 1/2	1 21/32	3/4	1.5048	1.5008	1.6568	1.6558	1.4988	1.4972
GSI-2426-16	1 1/2	1 21/32	1	1.5048	1.5008	1.6568	1.6558	1.4988	1.4972
GSI-2426-24	1 1/2	1 21/32	1 1/2	1.5048	1.5008	1.6568	1.6558	1.4988	1.4972
GSI-2629-20	1 5/8	1 25/32	1 1/4	1.6297	1.6258	1.7818	1.7808	1.6238	1.6222
GSI-2831-16	1 3/4	1 15/16	1	1.7547	1.7505	1.9381	1.9371	1.7487	1.7471
GSI-2831-24	1 3/4	1 15/16	1 1/2	1.7547	1.7505	1.9381	1.9371	1.7487	1.7471
GSI-2831-32	1 3/4	1 15/16	2	1.7547	1.7505	1.9381	1.9371	1.7487	1.7471
GSI-2831-40	1 3/4	1 15/16	2 1/2	1.7547	1.7505	1.9381	1.9371	1.7487	1.7471
GSI-2831-48	1 3/4	1 15/16	3	1.7547	1.7505	1.9381	1.9371	1.7487	1.7471
GSI-3235-16	2	2 3/16	1	2.0057	2.0011	2.1883	2.1871	1.9981	1.9969
GSI-3235-24	2	2 3/16	1 1/2	2.0057	2.0011	2.1883	2.1871	1.9981	1.9969
GSI-3235-32	2	2 3/16	2	2.0057	2.0011	2.1883	2.1871	1.9981	1.9969
GSI-3639-32	2 1/4	2 7/16	2	2.2577	2.2531	2.4377	2.4365	2.2507	2.2489
GSI-4043-32	2 2/4	2 11/16	2	2.5082	2.5035	2.6881	2.6869	2.5000	2.4999
GSI-4447-32	2 3/4	2 15/16	2	2.7570	2.7523	2.9370	2.9358	2.7500	2.7490
GSI-4851-32	3	3 3/16	2	3.0070	3.0023	3.1870	3.1858	3.0000	2.9990

* after pressfit. Testing methods ► page 59

iglidur® G | Product Range | Inch

Flange Bearing

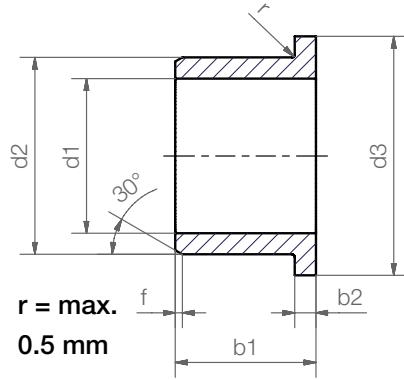

Order key

GFI-0203-02



- Length b1
- Outer diameter d2
- Inner diameter d1
- Inch
- Type (Form F)
- Material iglidur® G

Chamfer in relation to the d1

d1 [Inch]:	Ø 0.040–0.236	Ø 0.236–0.472	Ø 0.472–1.18	Ø > 1.18
f [Inch]:	0.012	0.019	0.031	0.047

Dimensions [Inch]

Part number	d1	d2	b1	d3	b2	d1*		Housing Bore		Shaft Size	
						max.	min.	max.	min.	max.	min.
GFI-0203-02	1/8	3/16	1/8	.312	.032	.1269	.1251	.1878	.1873	.1243	.1236
GFI-0203-03	1/8	3/16	3/16	.312	.032	.1269	.1251	.1878	.1873	.1243	.1236
GFI-0203-04	1/8	3/16	1/4	.312	.032	.1269	.1251	.1878	.1873	.1243	.1236
GFI-0203-06	1/8	3/16	3/8	.312	.032	.1269	.1251	.1878	.1873	.1243	.1236
GFI-0304-04	3/16	1/4	1/4	.375	.032	.1892	.1873	.2503	.2497	.1865	.1858
GFI-0304-06	3/16	1/4	3/8	.375	.032	.1892	.1873	.2503	.2497	.1865	.1858
GFI-0304-08	3/16	1/4	1/2	.375	.032	.1892	.1873	.2503	.2497	.1865	.1858
GFI-0405-04	1/4	5/16	1/4	.500	.032	.2521	.2498	.3128	.3122	.2490	.2481
GFI-0405-05	1/4	5/16	5/16	.500	.032	.2521	.2498	.3128	.3122	.2490	.2481
GFI-0405-06	1/4	5/16	3/8	.500	.032	.2521	.2498	.3128	.3122	.2490	.2481
GFI-0405-08	1/4	5/16	1/2	.500	.032	.2521	.2498	.3128	.3122	.2490	.2481
GFI-0405-12	1/4	5/16	3/4	.500	.032	.2521	.2498	.3128	.3122	.2490	.2481
GFI-0506-04	5/16	3/8	1/4	.562	.032	.3148	.3125	.3753	.3747	.3115	.3106
GFI-0506-06	5/16	3/8	3/8	.562	.032	.3148	.3125	.3753	.3747	.3115	.3106
GFI-0506-08	5/16	3/8	1/2	.562	.032	.3148	.3125	.3753	.3747	.3115	.3106
GFI-0506-12	5/16	3/8	3/4	.562	.032	.3148	.3125	.3753	.3747	.3115	.3106
GFI-0607-04	3/8	15/32	1/4	.687	.046	.3773	.3750	.4691	.4684	.3740	.3731
GFI-0607-05	3/8	15/32	5/16	.687	.046	.3773	.3750	.4691	.4684	.3740	.3731
GFI-0607-06	3/8	15/32	3/8	.687	.046	.3773	.3750	.4691	.4684	.3740	.3731
GFI-0607-08	3/8	15/32	1/2	.687	.046	.3773	.3750	.4691	.4684	.3740	.3731
GFI-0607-12	3/8	15/32	3/4	.687	.046	.3773	.3750	.4691	.4684	.3740	.3731
GFI-0607-14	3/8	15/32	7/8	.687	.046	.3773	.3750	.4691	.4684	.3740	.3731
GFI-0708-04	7/16	17/32	1/4	.750	.046	.4406	.4379	.5316	.5309	.4365	.4355
GFI-0708-08	7/16	17/32	1/2	.750	.046	.4406	.4379	.5316	.5309	.4365	.4355
GFI-0809-04	1/2	19/32	1/4	.875	.046	.5030	.5003	.5941	.5934	.4990	.4980

* after pressfit. Testing methods ► page 59



delivery from stock
time



prices price list online
www.igus.eu/eu/g



Flange Bearing

Dimensions [Inch]

Part number	d1	d2	b1	d3	b2	d1*		Housing Bore		Shaft Size	
						max.	min.	max.	min.	max.	min.
GFI-0809-05	1/2	19/32	5/16	.875	.046	.5030	.5003	.5941	.5934	.4990	.4980
GFI-0809-06	1/2	19/32	3/8	.875	.046	.5030	.5003	.5941	.5934	.4990	.4980
GFI-0809-08	1/2	19/32	1/2	.875	.046	.5030	.5003	.5941	.5934	.4990	.4980
GFI-0809-12	1/2	19/32	3/4	.875	.046	.5030	.5003	.5941	.5934	.4990	.4980
GFI-0809-16	1/2	19/32	1	.875	.046	.5030	.5003	.5941	.5934	.4990	.4980
GFI-1011-06	5/8	23/32	3/8	.937	.046	.6280	.6253	.7192	.7184	.6240	.6230
GFI-1011-08	5/8	23/32	1/2	.937	.046	.6280	.6253	.7192	.7184	.6240	.6230
GFI-1011-12	5/8	23/32	3/4	.937	.046	.6280	.6253	.7192	.7184	.6240	.6230
GFI-1011-14	5/8	23/32	7/8	.937	.046	.6280	.6253	.7192	.7184	.6240	.6230
GFI-1011-16	5/8	23/32	1	.937	.046	.6280	.6253	.7192	.7184	.6240	.6230
GFI-1011-24	5/8	23/32	1 1/2	.937	.046	.6280	.6253	.7192	.7184	.6240	.6230
GFI-1214-02	3/4	7/8	1/8	1.125	.062	.7541	.7505	.8755	.8747	.7491	.7479
GFI-1214-06	3/4	7/8	3/8	1.125	.062	.7541	.7505	.8755	.8747	.7491	.7479
GFI-1214-08	3/4	7/8	1/2	1.125	.062	.7541	.7505	.8755	.8747	.7491	.7479
GFI-1214-10	3/4	7/8	5/8	1.125	.062	.7541	.7505	.8755	.8747	.7491	.7479
GFI-1214-12	3/4	7/8	3/4	1.125	.062	.7541	.7505	.8755	.8747	.7491	.7479
GFI-1214-16	3/4	7/8	1	1.125	.062	.7541	.7505	.8755	.8747	.7491	.7479
GFI-1214-24	3/4	7/8	1 1/2	1.125	.062	.7541	.7505	.8755	.8747	.7491	.7479
GFI-1416-08	7/8	1	1/2	1.250	.062	.8791	.8757	1.0005	.9997	.8741	.8729
GFI-1416-12	7/8	1	3/4	1.250	.062	.8791	.8757	1.0005	.9997	.8741	.8729
GFI-1416-16	7/8	1	1	1.250	.062	.8791	.8757	1.0005	.9997	.8741	.8729
GFI-1416-20	7/8	1	1 1/4	1.250	.062	.8791	.8757	1.0005	.9997	.8741	.8729
GFI-1416-24	7/8	1	1 1/2	1.250	.062	.8791	.8757	1.0005	.9997	.8741	.8729
GFI-1618-08	1	1 1/8	1/2	1.375	.062	1.0041	1.0007	1.1255	1.1247	.9991	.9979
GFI-1618-12	1	1 1/8	3/4	1.375	.062	1.0041	1.0007	1.1255	1.1247	.9991	.9979
GFI-1618-16	1	1 1/8	1	1.375	.062	1.0041	1.0007	1.1255	1.1247	.9991	.9979
GFI-1618-20	1	1 1/8	1 1/4	1.375	.062	1.0041	1.0007	1.1255	1.1247	.9991	.9979
GFI-1618-24	1	1 1/8	1 1/2	1.375	.062	1.0041	1.0007	1.1255	1.1247	.9991	.9979
GFI-1820-12	1 1/8	1 9/32	3/4	1.562	.078	1.1288	1.1254	1.2818	1.2808	1.1238	1.1226
GFI-1820-24	1 1/8	1 9/32	1 1/2	1.562	.078	1.1288	1.1254	1.2818	1.2808	1.1238	1.1226
GFI-2022-06	1 1/4	1 13/32	3/8	1.687	.078	1.2548	1.2508	1.4068	1.4058	1.2488	1.2472
GFI-2022-12	1 1/4	1 13/32	3/4	1.687	.078	1.2548	1.2508	1.4068	1.4058	1.2488	1.2472
GFI-2022-14	1 1/4	1 13/32	7/8	1.687	.078	1.2548	1.2508	1.4068	1.4058	1.2488	1.2472
GFI-2022-16	1 1/4	1 13/32	1	1.687	.078	1.2548	1.2508	1.4068	1.4058	1.2488	1.2472
GFI-2022-20	1 1/4	1 13/32	1 1/4	1.687	.078	1.2548	1.2508	1.4068	1.4058	1.2488	1.2472
GFI-2022-24	1 1/4	1 13/32	1 1/2	1.687	.078	1.2548	1.2508	1.4068	1.4058	1.2488	1.2472
GFI-2224-16	1 3/8	1 17/32	1	1.875	.078	1.3798	1.3758	1.5318	1.5308	1.3738	1.3722
GFI-2426-12	1 1/2	1 21/32	3/4	2.000	.078	1.5048	1.5008	1.6568	1.6558	1.4988	1.4972
GFI-2426-16	1 1/2	1 21/32	1	2.000	.078	1.5048	1.5008	1.6568	1.6558	1.4988	1.4972
GFI-2426-24	1 1/2	1 21/32	1 1/2	2.000	.078	1.5048	1.5008	1.6568	1.6558	1.4988	1.4972
GFI-2831-16	1 3/4	1 15/16	1	2.375	.093	1.7547	1.7505	1.9381	1.9371	1.7487	1.7471
GFI-2831-24	1 3/4	1 15/16	1 1/2	2.375	.093	1.7547	1.7505	1.9381	1.9371	1.7487	1.7471

* after pressfit. Testing methods ► page 59



Flange Bearing

Dimensions [Inch]

Part number	d1	d2	b1	d3	b2	d1*		Housing Bore		Shaft Size	
						max.	min.	max.	min.	max.	min.
GFI-2831-32	1 3/4	1 15/16	2	2.375	.093	1.7547	1.7505	1.9381	1.9371	1.7487	1.7471
GFI-3235-16	2	2 3/16	1	2.625	.093	2.0057	2.0011	2.1883	2.1871	1.9981	1.9969
GFI-3235-24	2	2 3/16	1 1/2	2.625	.093	2.0057	2.0011	2.1883	2.1871	1.9981	1.9969
GFI-3235-32	2	2 3/16	2	2.625	.093	2.0057	2.0011	2.1883	2.1871	1.9981	1.9969
GFI-3639-32	2 1/4	2 7/16	2	2.750	.093	2.2577	2.2531	2.4377	2.4365	2.2507	2.2489
GFI-4043-32	2 1/2	2 11/16	2	3.125	.093	2.5082	2.5035	2.6881	2.6869	2.5000	2.4999
GFI-4447-32	2 3/4	2 15/16	2	3.375	.093	2.7570	2.7523	2.9370	2.9358	2.7500	2.7490

* after pressfit. Testing methods ► page 59



delivery from stock
time



prices price list online
www.igus.eu/eu/g

Thrust Washer

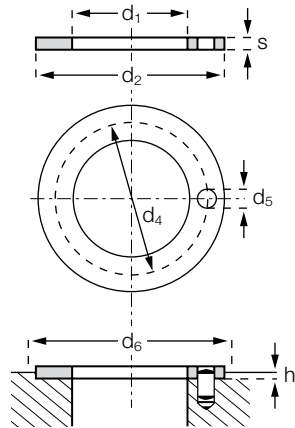

Order key

GTI-0814-01

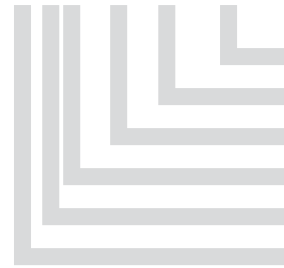

Thickness s
Outer diameter d2
Inner diameter d1
Inch
Type (Form T)
Material iglidur® G

Dimensions according to ISO 3547-1 and special dimensions

Dimensions [Inch]

Part number	d1 +.010	d2 -.010	s -.0020	d4 ±.005	d5 .015 + .005	h +.008	d6 +.005
GTI-0814-01	.500	.875	.0585	.692	.067	.040	.875
GTI-1018-01	.625	1.125	.0585	.880	.099	.040	1,125
GTI-1220-01	.750	1.250	.0585	1,005	.099	.040	1,250
GTI-1424-01	.875	1.500	.0585	1,192	.130	.040	1,500
GTI-1628-01	1.000	1.750	.0585	1,380	.130	.040	1,750
GTI-2034-01	1.250	2.125	.0585	1,692	.161	.040	2,125
GTI-2440-01	1.500	2.500	.0585	2,005	.192	.040	2,500
GTI-2844-01	1.750	2.750	.0585	2,255	.192	.040	2,750
GTI-3248-01	2.000	3.000	.0895	2,505	.192	.070	3,000



delivery from stock
time



prices price list online
www.igus.eu/eu/g