

Nuts

Single Nut with Flange FEM-E-C

Standard series

Mounting dimensions
per DIN 69 051, Part 5
Flange type C

With standard seals
Reinforced seals, see page 112
With backlash, reduced backlash,
preload 2%; 3%; 5%
For precision-rolled screws SN-R
of tolerance grade T5, T7, T9

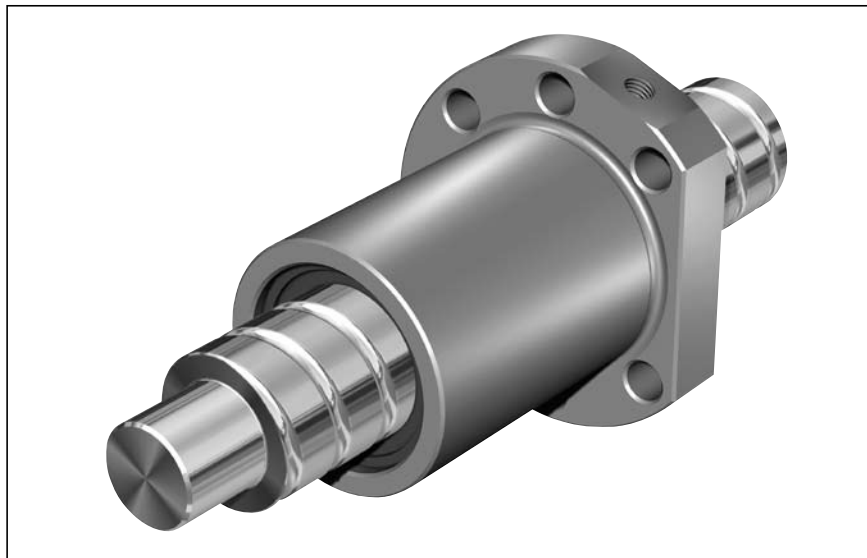

Ordering code: **FEM-E-C** 20 x 5R x 3-4 1 2 T7 R 82Z120 41Z120 1250 0 1

d_0 = nominal diameter
 P = lead
(R = right-hand, L = left-hand)
 D_w = ball diameter
 i = number of ball track turns

Category	Size $d_0 \times P \times D_w - i$	Part number	Load ratings		Linear speed ¹⁾ v_{max} (m/min)
			dyn. C (N)	stat. C_0 (N)	
A	16 x 5R x 3 - 4	R1502 010 65	12300	16100	30
A	16 x 10R x 3 - 3	R1502 040 85	9600	12300	60
A	16 x 16R x 3 - 3	R1502 060 65	9300	12000	96
A	20 x 5R x 3 - 4	R1502 110 85	14300	21500	30
A	20 x 20R x 3.5 - 3	R1502 170 65	13300	18800	120
A	25 x 5R x 3 - 4	R1502 210 85	15900	27200	30
A	25 x 10R x 3 - 4	R1502 240 85	15700	27000	60
A	25 x 25R x 3.5 - 3	R1502 280 65	14700	23300	150
A	32 x 5R x 3.5 - 4	R1502 310 85	21600	40000	23
A	32 x 10R x 3.969 - 5	R1502 340 86	31700	58300	47
A	32 x 20R x 3.969 - 3	R1502 370 65	19700	33700	94
A	32 x 32R x 3.969 - 3	R1502 390 65	19500	34000	150
B	40 x 5R x 3.5 - 5	R1502 410 86	29100	64100	19
A	40 x 10R x 6 - 4	R1502 440 85	50000	86400	38
C	40 x 12R x 6 - 4	R1502 450 65	49900	86200	45
A	40 x 16R x 6 - 4	R1502 460 65	49700	85900	60
A	40 x 20R x 6 - 3	R1502 470 85	37900	62800	75
A	40 x 40R x 6 - 3	R1502 490 65	37000	62300	150
B	50 x 5R x 3.5 - 5	R1502 510 86	32000	81300	15
A	50 x 10R x 6 - 6	R1502 540 86	79700	166500	30
C	50 x 12R x 6 - 6	R1502 550 66	79600	166400	36
B	50 x 16R x 6 - 6	R1502 560 66	79400	166000	48
A	50 x 20R x 6.5 - 5	R1502 570 86	75700	149700	60
B	50 x 40R x 6.5 - 3	R1502 590 65	46500	85900	120
B	63 x 10R x 6 - 6	R1502 640 86	88800	214300	24
B	63 x 20R x 6.5 - 5	R1502 670 86	83900	190300	48
C	63 x 40R x 6.5 - 3	R1502 690 65	53400	114100	95
C	80 x 10R x 6.5 - 6	R1502 740 86	108400	291700	19
B	80 x 20R x 12.7 - 6 ²⁾	R1502 770 96	262700	534200	30

1) See page 101 Characteristic speed $d_0 \cdot n$ and page 124 Critical speed n_{cr}

2) Nuts 80 x 20R x 12.7 - 6 available up to a thread length of 2500 mm, with preload

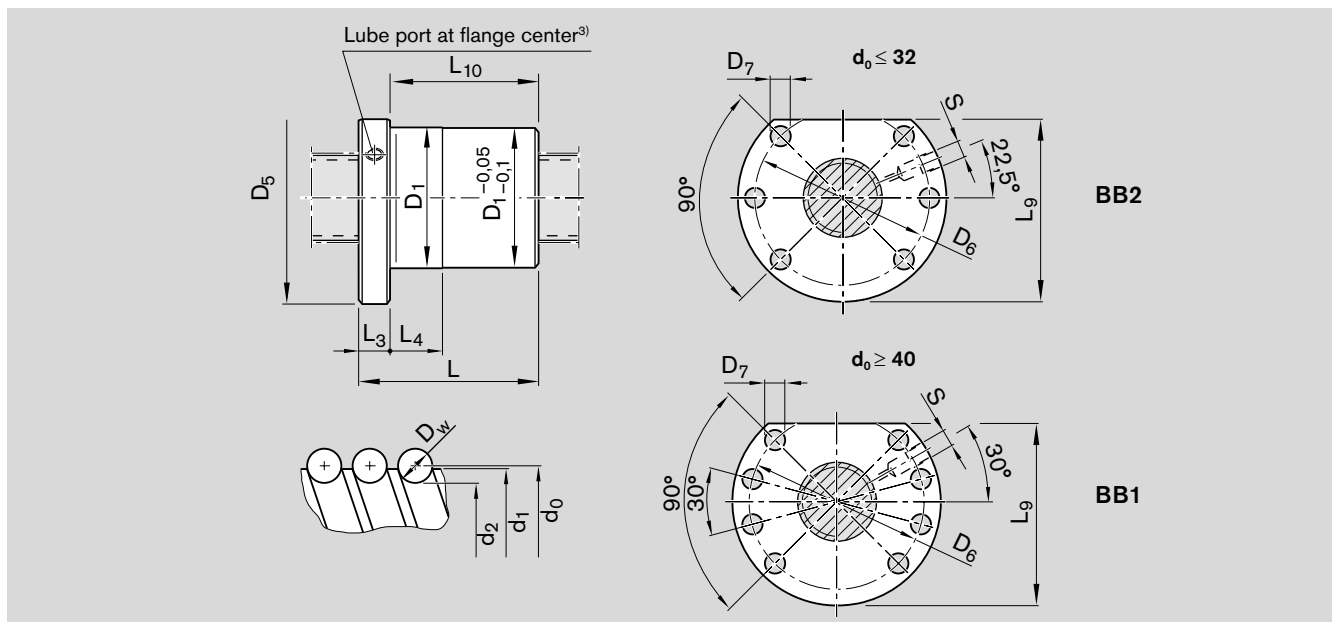

Size $d_0 \times P \times D_w - i$	Dimensions (mm)													Weight m (kg)
	d_1	d_2	D_1 g6	D_5	Hole pattern	D_6	D_7	L	L_3	L_4	L_9	L_{10}	$S^3)$	
16 x 5R x 3 - 4	15.0	12.9	28	48	BB2	38	5.5	38	12	10	44.0	26	M6	0.19
16 x 10R x 3 - 3	15.0	12.9	28	48	BB2	38	5.5	45	12	16	44.0	33	M6	0.21
16 x 16R x 3 - 3	15.0	12.9	28	48	BB2	38	5.5	61	12	20	44.0	49	M6	0.26
20 x 5R x 3 - 4	19.0	16.9	36	58	BB2	47	6.6	40	12	10	51.0	28	M6	0.31
20 x 20R x 3.5 - 3	19.3	16.7	36	58	BB2	47	6.6	77	12	25	51.0	65	M6	0.49
25 x 5R x 3 - 4	24.0	21.9	40	62	BB2	51	6.6	45	12	10	55.0	33	M6	0.36
25 x 10R x 3 - 4	24.0	21.9	40	62	BB2	51	6.6	64	12	16	55.0	52	M6	0.47
25 x 25R x 3.5 - 3	24.0	21.4	40	62	BB2	51	6.6	95	12	30	55.0	83	M6	0.63
32 x 5R x 3.5 - 4	31.0	28.4	50	80	BB2	65	9.0	48	13	10	71.0	35	M6	0.62
32 x 10R x 3.969 - 5	31.0	27.9	50	80	BB2	65	9.0	77	13	16	71.0	64	M6	0.84
32 x 20R x 3.969 - 3	31.0	27.9	50	80	BB2	65	9.0	84	13	25	71.0	71	M6	0.90
32 x 32R x 3.969 - 3	31.0	27.9	50	80	BB2	65	9.0	120	13	40	71.0	107	M6	1.21
40 x 5R x 3.5 - 5	39.0	36.4	63	93	BB1	78	9.0	54	15	10	81.5	39	M8x1	1.03
40 x 10R x 6 - 4	38.0	33.8	63	93	BB1	78	9.0	70	15	16	81.5	55	M8x1	1.19
40 x 12R x 6 - 4	38.0	33.8	63	93	BB1	78	9.0	75	15	25	81.5	60	M8x1	1.27
40 x 16R x 6 - 4	38.0	33.8	63	93	BB1	78	9.0	90	15	25	81.5	75	M8x1	1.51
40 x 20R x 6 - 3	38.0	33.8	63	93	BB1	78	9.0	88	15	25	81.5	73	M8x1	1.44
40 x 40R x 6 - 3	38.0	33.8	63	93	BB1	78	9.0	142	15	45	81.5	127	M8x1	2.16
50 x 5R x 3.5 - 5	49.0	46.4	75	110	BB1	93	11.0	54	15	10	97.5	39	M8x1	1.39
50 x 10R x 6 - 6	48.0	43.8	75	110	BB1	93	11.0	90	18	16	97.5	72	M8x1	2.14
50 x 12R x 6 - 6	48.0	43.8	75	110	BB1	93	11.0	105	18	25	97.5	87	M8x1	2.38
50 x 16R x 6 - 6	48.0	43.8	75	110	BB1	93	11.0	128	18	25	97.5	110	M8x1	2.75
50 x 20R x 6.5 - 5	48.0	43.4	75	110	BB1	93	11.0	132	18	25	97.5	114	M8x1	2.73
50 x 40R x 6.5 - 3	48.0	43.4	75	110	BB1	93	11.0	149	18	45	97.5	131	M8x1	3.04
63 x 10R x 6 - 6	61.0	56.8	90	125	BB1	108	11.0	90	22	16	110.0	68	M8x1	2.56
63 x 20R x 6.5 - 5	61.0	56.4	95	135	BB1	115	13.5	132	22	25	117.5	110	M8x1	4.51
63 x 40R x 6.5 - 3	61.0	56.4	95	135	BB1	115	13.5	149	22	45	117.5	127	M8x1	5.04
80 x 10R x 6.5 - 6	78.0	73.3	105	145	BB1	125	13.5	95	22	16	127.5	73	M8x1	3.40
80 x 20R x 12.7 - 6	76.0	67.0	125	165	BB1	145	13.5	170	25	25	147.5	145	M8x1	10.20

3) Lube port machining: flat surface $L_3 \leq 13$ mm, countersink $L_3 > 14$ mm