

# igidur® Clips2 – Suitable for High Loads



Low bearing clearance, high precision

Easy installation due to chamfered edge

Material: iglidur® M250

Maintenance-free and predictable service life

igidur® Clips2

Phone +44 (0) 16 04 - 67 72 40  
Fax +44 (0) 16 04 - 67 72 45

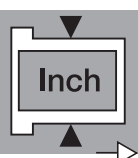



## iglidur® Clips2 | Flange Bearing

These iglidur® M250 self lubricating plain bearings are defined by their impact strength, vibration dampening, and wear resistant properties. They excel in applications in which vibration dampening is necessary, for example, in fitness and packaging machines.

iglidur® Clips2

1 style  
> 10 dimensions  
Ø 4–25 mm



### Special properties:

- Low bearing clearance, high precision
- Easy installation due to chamfered edge
- iglidur® M250 material
- Maintenance-free and predictable service life

Phone +44 (0) 16 04 - 67 72 40  
Fax +44 (0) 16 04 - 67 72 45

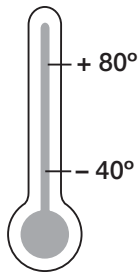

### Material Table

General properties	Unit	iglidur® M250	Testing method
Density	g/cm <sup>3</sup>	1,14	
Colour		Charcoal	
Max. moisture absorption at 23°C / 50% r.F.	% weight	1,4	DIN 53495
Max. moisture absorption	% weight	7,6	
Coefficient of sliding friction, dynamic against steel $\mu$		0,18 - 0,40	
p x v Value, max. (dry)	MPa x m/s	0,12	
<b>Mechanical properties</b>			
Modulus of elasticity	MPa	2.700	DIN 53457
Tensile strength at 20°C	MPa	112	DIN 53452
Compressive strength	MPa	52	
Max. recommended surface pressure (20°C)	MPa	20	
Shore D hardness		79	DIN 53505
<b>Physical and thermal properties</b>			
Max. long term operating temperature	°C	88	
Max. short term operating temperature	°C	170	
Min. operating temperature	°C	-40	
Thermal conductivity	W/m x K	0,24	ASTM C 177
Coefficient of thermal expansion	K <sup>-1</sup> x 10 <sup>-5</sup>	10	DIN 53752
<b>Electrical properties</b>			
Specific volume resistance	$\Omega$ cm	> 10 <sup>13</sup>	DIN IEC 93
Surface resistance	$\Omega$	> 10 <sup>11</sup>	DIN 53482

iglus® UK Ltd.



Material:  
iglidur® M250  
▶ chapter 4

Internet [www.igus.co.uk](http://www.igus.co.uk)  
E-mail [sales@igus.co.uk](mailto:sales@igus.co.uk)

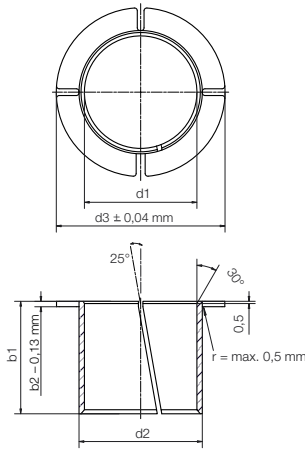

Data in mm

Structure – part no.

**MY M-04-04**

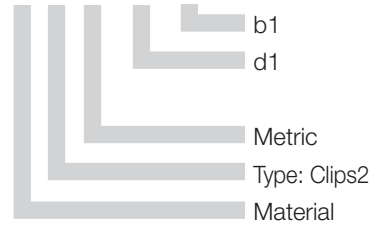

### Dimensions [mm]

iglidur® Clips2

Part No.	d1	d1* Tolerance	d2**	d3 ±0,40	b1 -0,40	b2 -0,13
MYM-04-04	4	+0,025/+0,075	5,20	7,00	4,00	0,60
MYM-05-05	5	+0,025/+0,075	6,20	8,00	5,00	0,60
MYM-06-06	6	+0,025/+0,075	7,20	9,50	6,00	0,60
MYM-08-08	8	+0,025/+0,075	9,60	12,00	8,00	0,80
MYM-10-10	10	+0,025/+0,075	11,60	15,00	10,00	0,80
MYM-12-12	12	+0,025/+0,075	13,60	18,00	12,00	0,80
MYM-14-14	14	+0,025/+0,075	15,60	21,00	14,00	0,80
MYM-16-16	16	+0,025/+0,075	17,60	24,00	16,00	0,80
MYM-20-20	20	+0,025/+0,075	21,60	30,00	20,00	0,80
MYM-25-25	25	+0,025/+0,075	27,40	37,50	25,00	1,20

\* d1 measurement is measured with a plug gauge after fitting into a reference housing d2 +0.005 mm.

\*\* Recommended housing bore tolerance: H9

Phone +44 (0) 1604 - 67 72 40  
Fax +44 (0) 1604 - 67 72 45



### Order example

Our price breaks are defined by the order quantity.

1- 9	25-49	100-199	500- 999	2500-4999
10-24	50-99	200-499	1000-2499	

For the current prices please visit the igus®-Homepage [www.igus.co.uk](http://www.igus.co.uk)

No minimum order quantities, no surcharges.



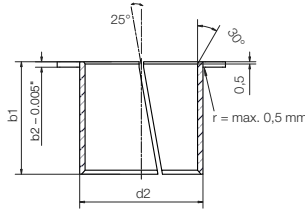
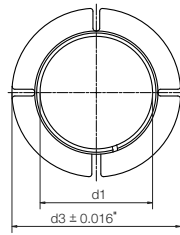

Data in mm

Structure – part no.

**MY I-03-03**

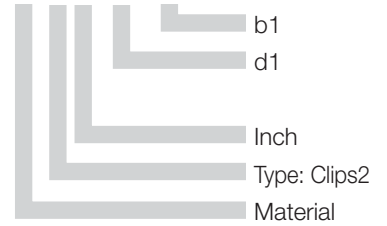

iglidur® Clips2

Phone +44 (0) 16 04 - 67 72 40  
Fax +44 (0) 16 04 - 67 72 45

iglus® UK Ltd.

Internet [www.igus.co.uk](http://www.igus.co.uk)  
E-mail [sales@igus.co.uk](mailto:sales@igus.co.uk)

### Dimensions [inch]

iglidur® Clips2

Part No.	d1	shaft diameter		d2	housing bore		d3	b1 tolerance		
		Min.	Max.		Min.	Max.				
MYI-03-03	3/16	,1875	,1865	0,2339	,2351	,2339	19/61	3/16	-0,016	0,0252
MYI-04-04	1/4	,0025	,2490	0,2965	,2979	,2965	13/32	1/4	-0,016	0,0252
MYI-05-05	5/16	,3125	,3115	0,3744	,3758	,3744	1/2	5/16	-0,017	0,0299
MYI-06-06	3/8	,3750	,3740	0,4370	,4387	,4370	19/32	3/8	-0,017	0,0299
MYI-07-07	7/16	,4375	,4365	0,4996	,5013	,4996	21/32	7/16	-0,017	0,0299
MYI-08-06	1/2	,5000	,4990	0,5618	,5635	,5618	3/8	3/4	-0,018	0,0299
MYI-08-08	1/2	,5000	,4990	0,5618	,5635	,5618	3/4	1/2	-0,018	0,0299
MYI-10-07	5/8	,6250	,6240	0,6870	,6887	,6870	15/16	7/16	-0,018	0,0299
MYI-10-10	5/8	,6250	,6240	0,6870	,6887	,6870	15/16	5/8	-0,018	0,0299
MYI-10-18	5/8	,6250	,6240	0,6870	,6887	,6870	15/16	1 1/8	-0,018	0,0299
MYI-12-12	3/4	,7500	,7490	0,8118	,8139	,8118	1 1/8	3/4	-0,019	0,0299
MYI-12-18	3/4	,7500	,7490	0,8118	,8139	,8118	1 1/8	1 1/8	-0,019	0,0299
MYI-14-7,5	7/8	,8750	,8740	0,9370	,9391	,9370	1 5/16	15/32	-0,019	0,0299
MYI-14-14	7/8	,8750	,8740	0,9370	,9391	,9370	1 5/16	7/8	-0,019	0,0299
MYI-16-14	1	1,0000	,9985	1,0933	1,0954	1,0933	1 1/2	7/8	-0,020	0,0449
MYI-16-16	1	1,0000	,9985	1,0933	1,0954	1,0933	1	1	-0,020	0,0449