

THIS DRAWING IS UNPUBLISHED. RELEASED FOR PUBLICATION 20
 © COPYRIGHT 20 BY TYCO ELECTRONICS CORPORATION. ALL RIGHTS RESERVED.

LOC	DIST	REVISIONS					
CM	00	P	LTR	DESCRIPTION	DATE	DWN	APVD
			A	REVISED PER ECR-10-025509	15DEC2010	HMR	DD

- 1 MATERIALS AND FINISH:
 - HOUSING: LCP, COLOR: NATURAL
 - CONTACTS: COPPER ALLOY, FINISH: Sn OVER Ni
- 2. COMPLY WITH DIRECTIVE 2002/95/EC (ROHS).
- 3. THIS PRODUCT HAS NOT COMPLETED VALIDATION TESTING.
- 4. 18-22AWG SOLID OR STRANDED WIRE, PRE-BONDED, 19 STRANDS OR LESS:
 - 18AWG MAX INSULATION OD: 2.20
 - 20AWG MAX INSULATION OD: 1.90
 - 22AWG MAX INSULATION OD: 1.70
 - 24AWG MAX INSULATION OD: 1.45
- 5. PACKAGE IN TAPE AND REEL PER EIA-481 SPECIFICATION, EXCEPT I POSITION CONNECTOR.
- 6 WIRE SIZE MARKING IN APPROXIMATE LOCATION SHOWN.
- 7 DATUMS AND BASIC DIMENSIONS ESTABLISHED BY CUSTOMER.
- 8 COLOR CODE MARKING, STRAIGHT LINE.
- 9 I POSITION ASSEMBLY DOES NOT COMPLY WITH EIA 481 SPECIFICATION.
- 10 PART NUMBER, NOT UL RECOGNIZED

COLOR CODE	DIM D	WIRE SIZE	POSN	COLOR	PART NUMBER
BLUE	9.70	20 AWG	2	BLACK	5-2106003-2 ¹⁰
RED	17.70	24 AWG	4	NATURAL	3-2106003-4
	13.70	24 AWG	3	NATURAL	3-2106003-3
	9.70	24 AWG	2	NATURAL	3-2106003-2
	5.70	24 AWG	1	NATURAL	3-2106003-1
GREEN	17.70	22 AWG	4	NATURAL	2-2106003-4 ⁹
	13.70	22 AWG	3	NATURAL	2-2106003-3
	9.70	22 AWG	2	NATURAL	2-2106003-2
	5.70	22 AWG	1	NATURAL	2-2106003-1 ⁹
BLUE	17.70	20 AWG	4	NATURAL	1-2106003-4
	13.70	20 AWG	3	NATURAL	1-2106003-3
	9.70	20 AWG	2	NATURAL	1-2106003-2
	5.70	20 AWG	1	NATURAL	1-2106003-1 ⁹
YELLOW	17.70	18 AWG	4	NATURAL	2106003-4
	13.70	18 AWG	3	NATURAL	2106003-3
	9.70	18 AWG	2	NATURAL	2106003-2
	5.70	18 AWG	1	NATURAL	2106003-1 ⁹

THIS DRAWING IS A CONTROLLED DOCUMENT FOR TYCO ELECTRONICS CORPORATION. IT IS SUBJECT TO CHANGE AND THE CONTROLLING ENGINEERING ORGANIZATION SHOULD BE CONTACTED FOR THE LATEST REVISION.		DWN C DAILY 09DEC2008	Tyco Electronics Tyco Electronics Harrisburg, PA 17105-3608	
DIMENSIONS: mm		CHK J DYER 09DEC2008	NAME ASSEMBLY, IDC SSL CONNECTOR, SMT, CLOSED END	
TOLERANCES UNLESS OTHERWISE SPECIFIED: 0 PLC ± 1 PLC ±0.5 2 PLC ±0.13 3 PLC ± 4 PLC ± ANGLES ± FINISH		APVD -	PRODUCT SPEC 108-2404	RESTRICTED TO -
MATERIAL		APPLICATION SPEC 114-13266	SIZE A2	CAGE CODE 00779
CUSTOMER DRAWING		WEIGHT -	DRAWING NO 2106003	REV A
		SCALE 2:1		SHEET 1 OF 4

4

3

2

1

THIS DRAWING IS UNPUBLISHED. RELEASED FOR PUBLICATION 20
 © COPYRIGHT 20 BY TYCO ELECTRONICS CORPORATION. ALL RIGHTS RESERVED.

LOC	DIST	REVISIONS					
CM	00	P	LTR	DESCRIPTION	DATE	DWN	APVD
		-		SEE SHEET 1			

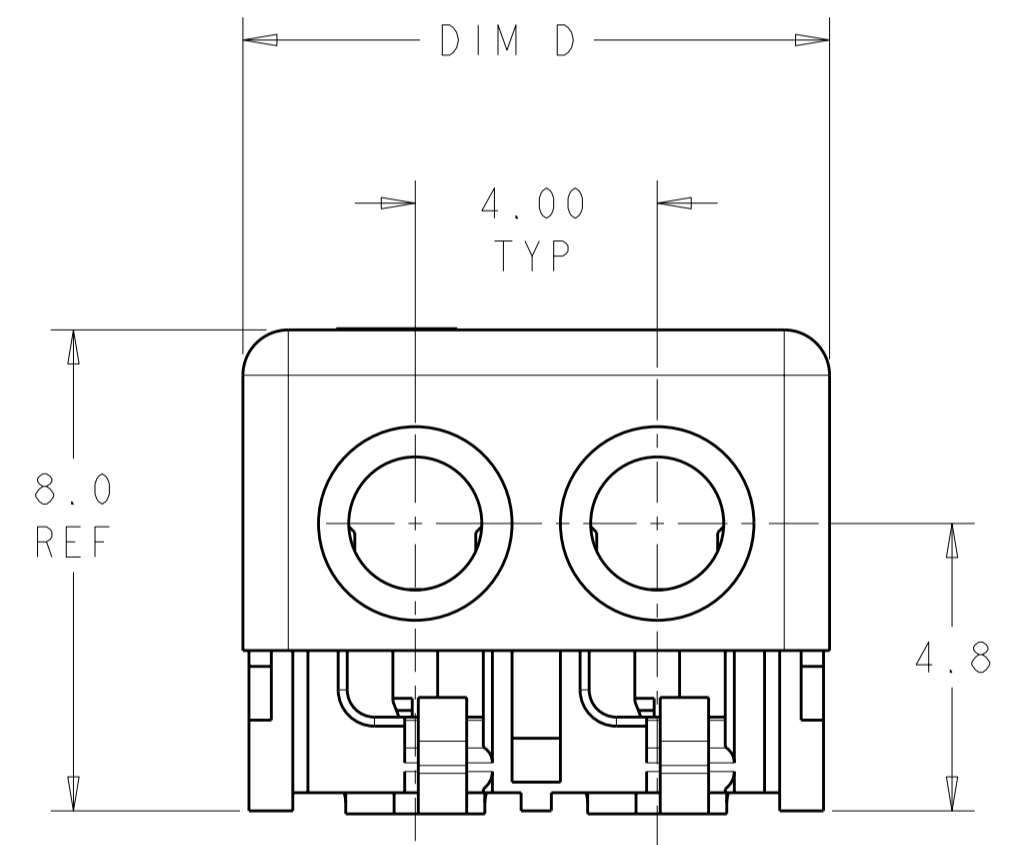
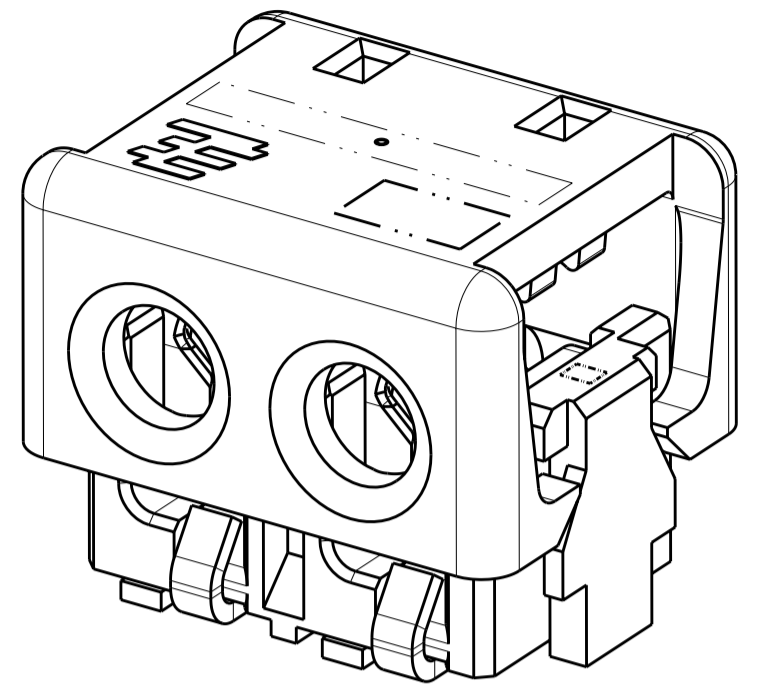
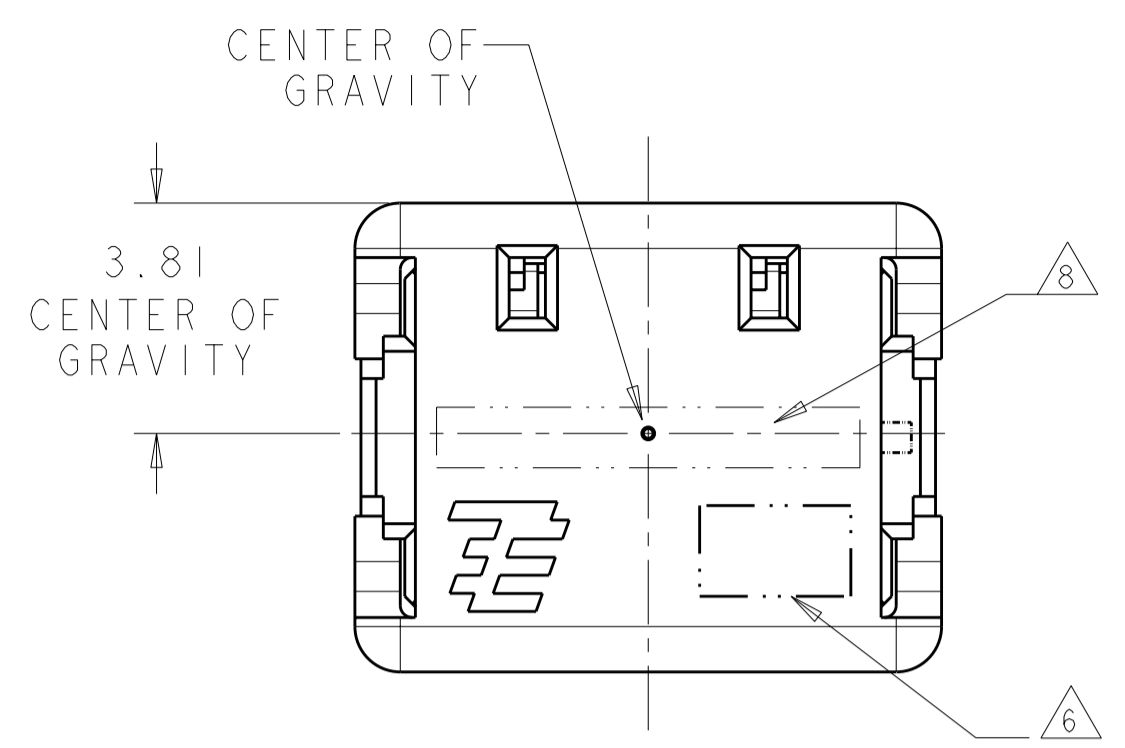

2 POSITION
SHOWN AS SHIPPED

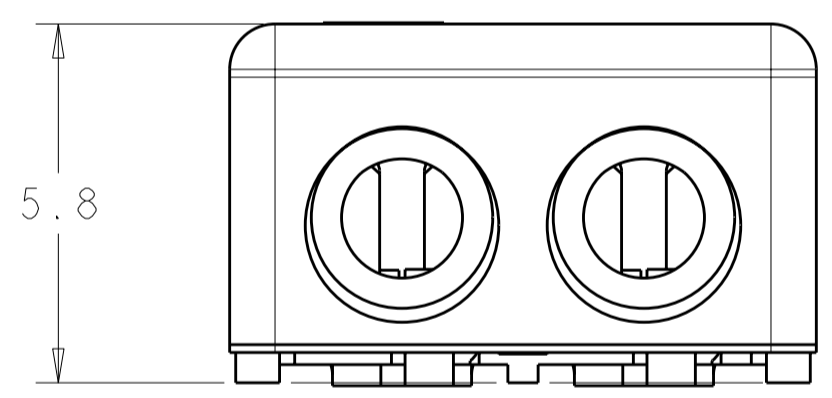
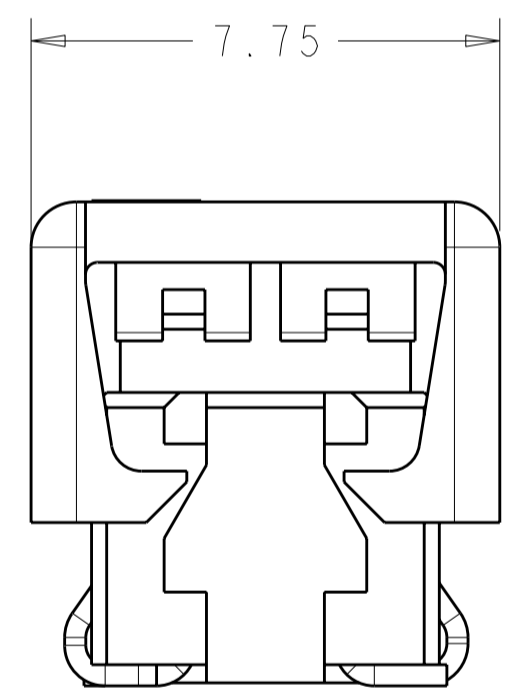

2 POSITION
SHOWN CLOSED
SCALE 8:1

THIS DRAWING IS A CONTROLLED DOCUMENT FOR TYCO ELECTRONICS CORPORATION IT IS SUBJECT TO CHANGE AND THE CONTROLLING ENGINEERING ORGANIZATION SHOULD BE CONTACTED FOR THE LATEST REVISION.		DWN C DAILY 09DEC2008	Tyco Electronics Harrisburg, PA 17105-3608	
DIMENSIONS: mm		CHK J DYER 09DEC2008	NAME ASSEMBLY, IDC SSL CONNECTOR, SMT, CLOSED END	
TOLERANCES UNLESS OTHERWISE SPECIFIED:		APVD -	RESTRICTED TO -	
0 PLC ±-		PRODUCT SPEC 108-2404	SIZE A200779	
1 PLC ±0.5		APPLICATION SPEC 114-13266	CAGE CODE C-2106003	
2 PLC ±0.13		WEIGHT -	DRAWING NO -	
3 PLC ±-		SCALE 2:1 SHEET 2 OF 4 REV A		
4 PLC ±-		CUSTOMER DRAWING		
ANGLES ±-				
FINISH ±-				

THIS DRAWING IS UNPUBLISHED. RELEASED FOR PUBLICATION 20
 © COPYRIGHT 20 BY TYCO ELECTRONICS CORPORATION. ALL RIGHTS RESERVED.

LOC	DIST	REVISIONS			
P	LTR	DESCRIPTION	DATE	DWN	APVD
-	-	SEE SHEET 1	-	-	-

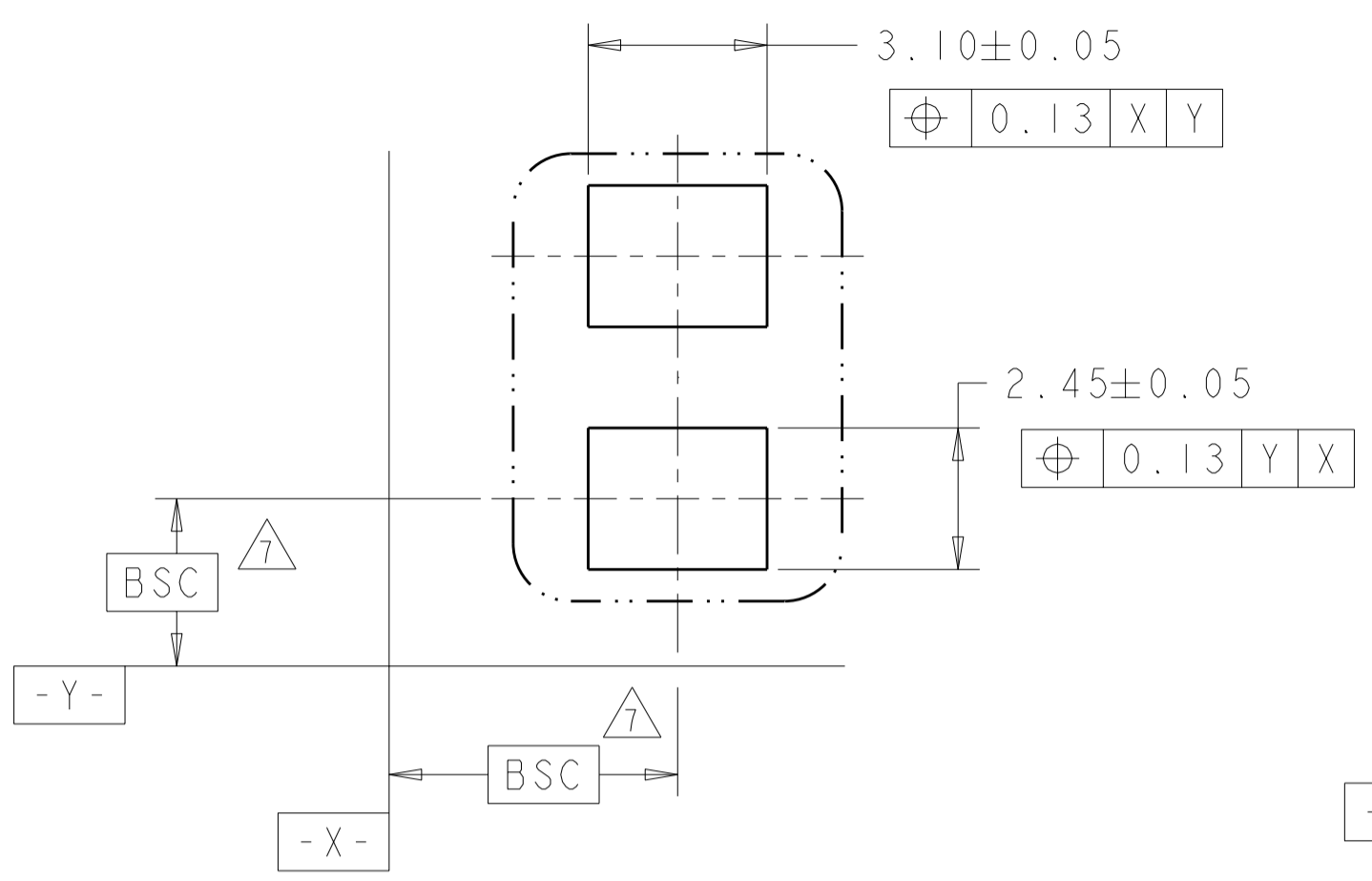

1 POSITION
RECOMMENDED PAD LAYOUT
SCALE 8:1

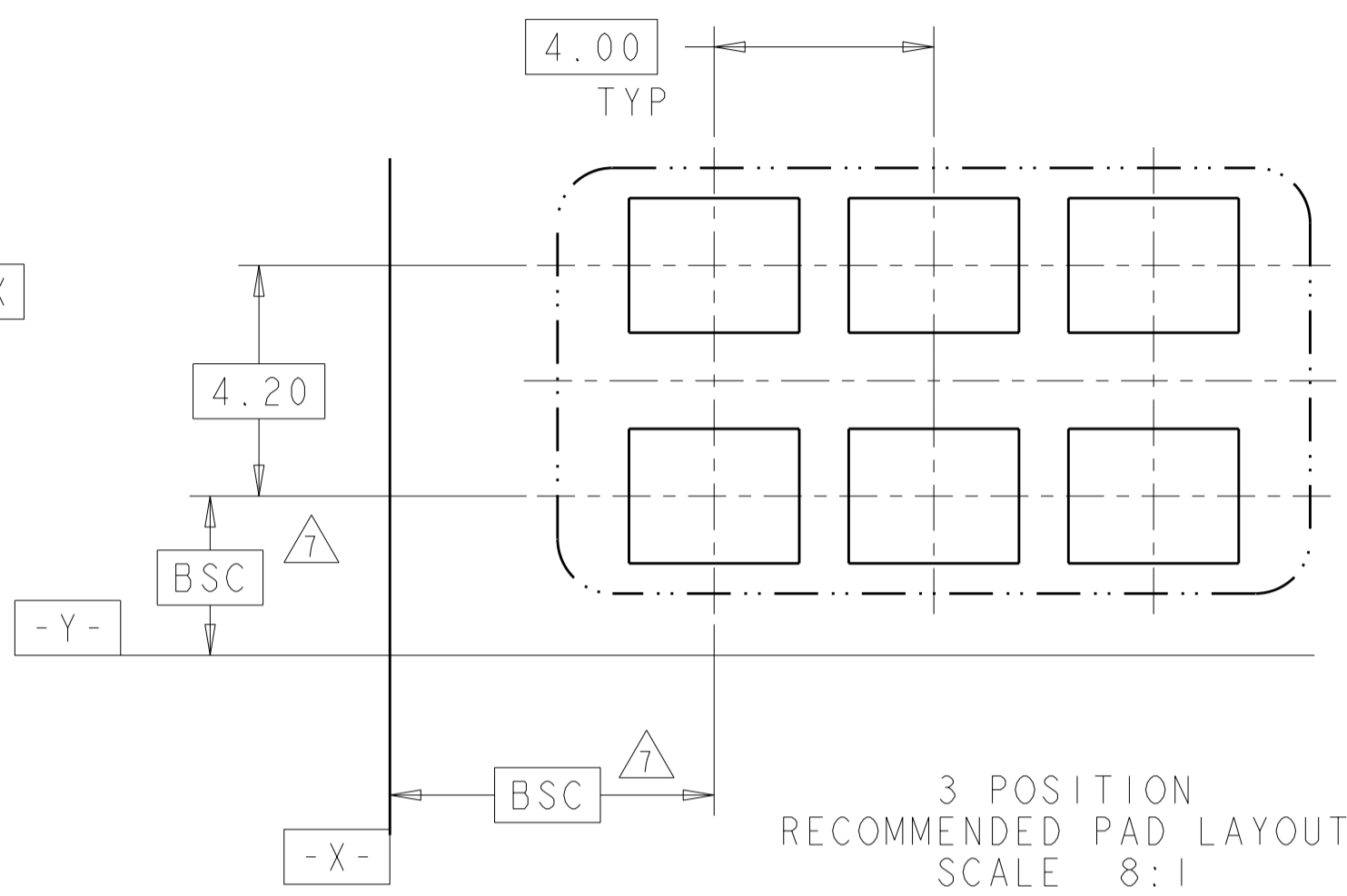

3 POSITION
RECOMMENDED PAD LAYOUT
SCALE 8:1

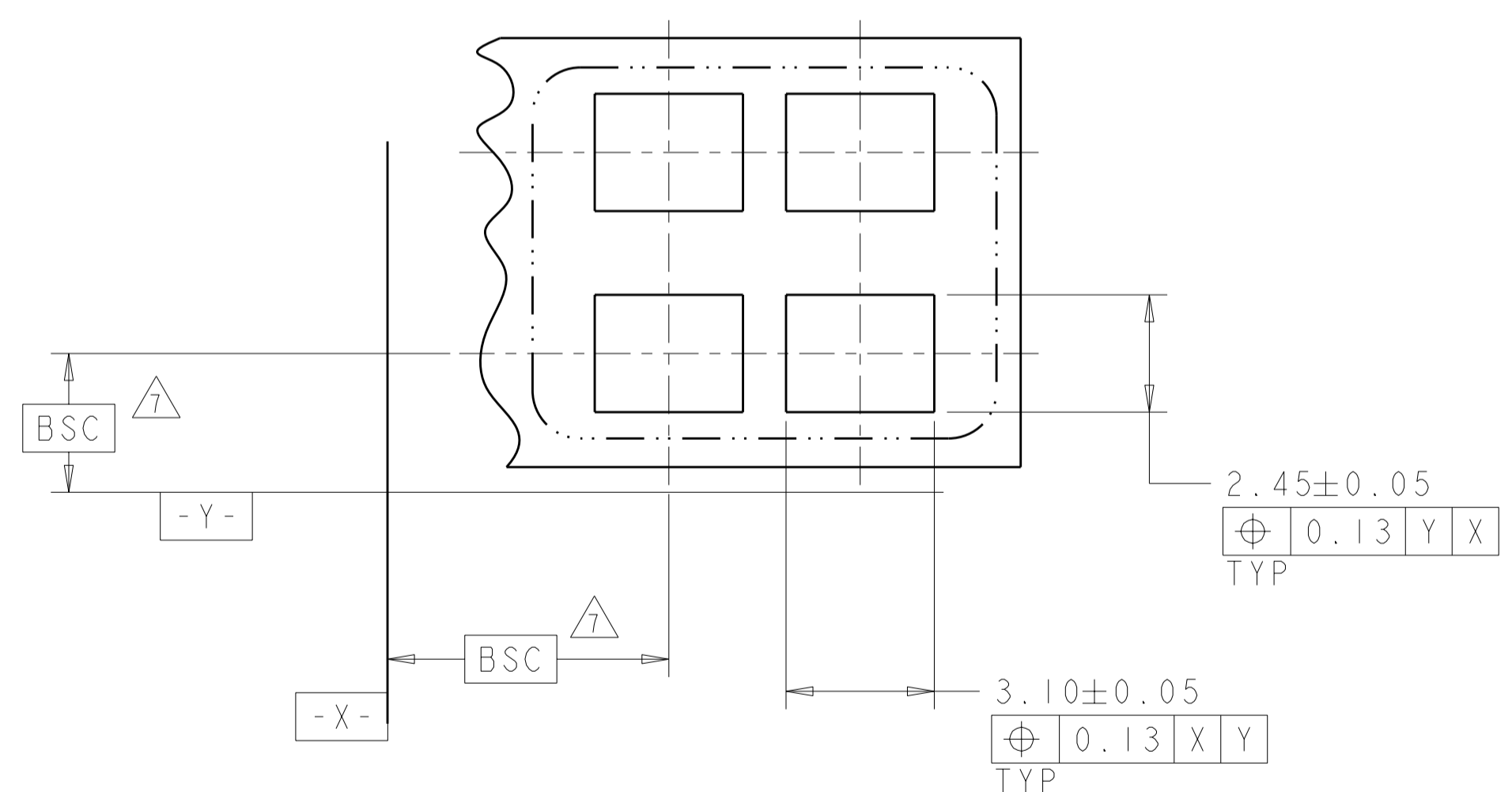

2 POSITION
RECOMMENDED PAD LAYOUT
SCALE 8:1

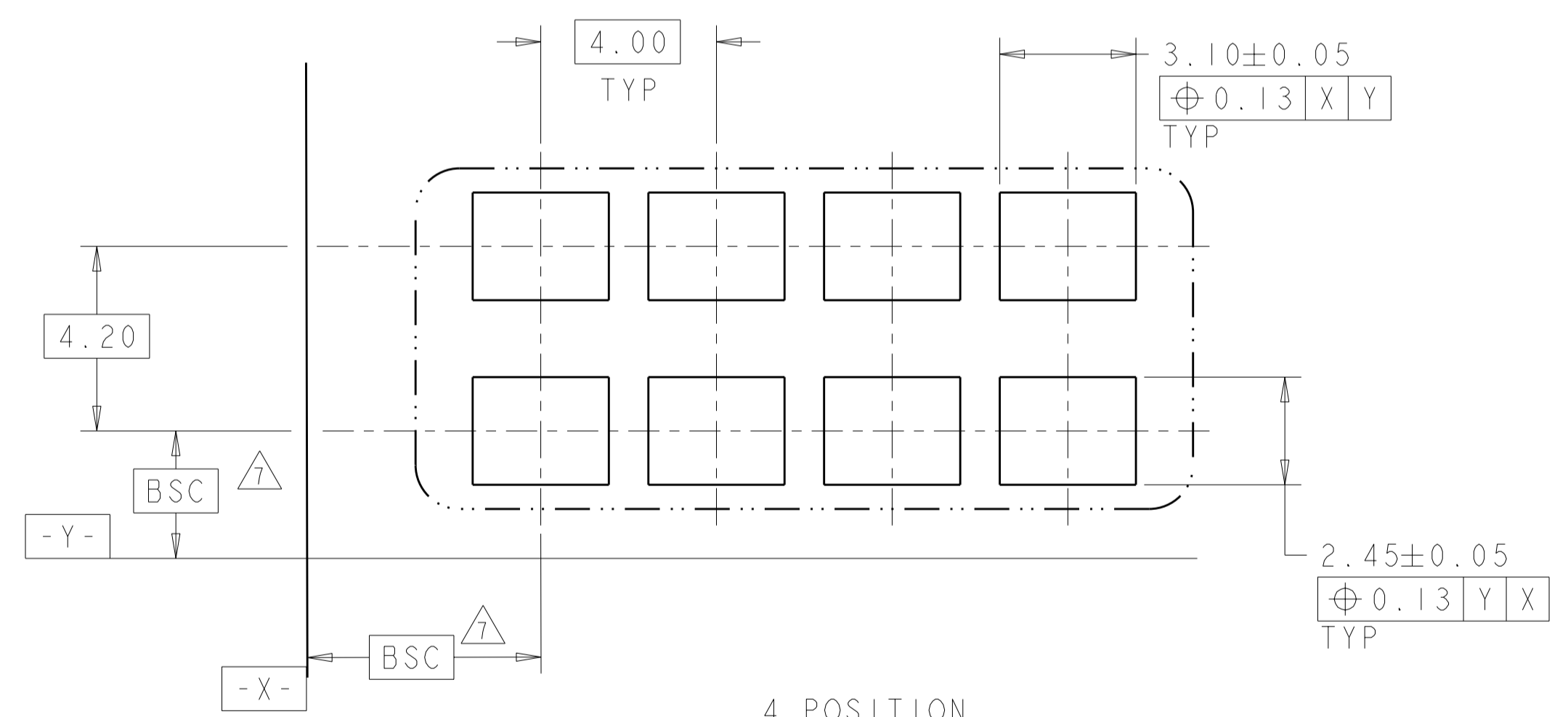

4 POSITION
RECOMMENDED PAD LAYOUT
SCALE 8:1

THIS DRAWING IS A CONTROLLED DOCUMENT FOR TYCO ELECTRONICS CORPORATION. IT IS SUBJECT TO CHANGE AND THE CONTROLLING ENGINEERING ORGANIZATION SHOULD BE CONTACTED FOR THE LATEST REVISION.		DWN C DAILY 09DEC2008	Tyco Electronics Harrisburg, PA 17105-3608	
DIMENSIONS: mm		CHK J DYER 09DEC2008	NAME ASSEMBLY, IDC SSL CONNECTOR, SMT, CLOSED END	
TOLERANCES UNLESS OTHERWISE SPECIFIED: 0 PLC ± 1 PLC ±0.5 2 PLC ±0.13 3 PLC ± 4 PLC ± ANGLES ± FINISH		APVD -	PRODUCT SPEC 108-2404	RESTRICTED TO -
MATERIAL		APPLICATION SPEC 114-13266	SIZE A2b0779	DRAWING NO C=2106003
		WEIGHT -	SCALE 2:1	SHEET 3 OF 4
		CUSTOMER DRAWING	REV A	

THIS DRAWING IS UNPUBLISHED. RELEASED FOR PUBLICATION 20
 © COPYRIGHT 20 BY TYCO ELECTRONICS CORPORATION. ALL RIGHTS RESERVED.

LOC	DIST	REVISIONS					
CM	00	P	LTR	DESCRIPTION	DATE	DWN	APVD
		-		SEE SHEET 1			

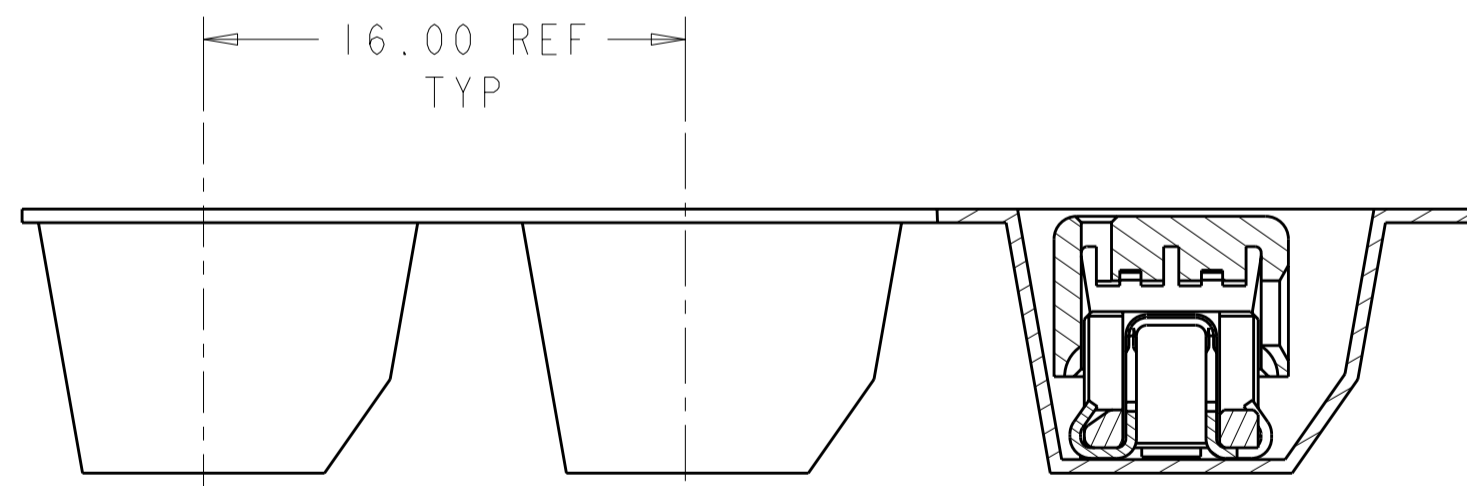
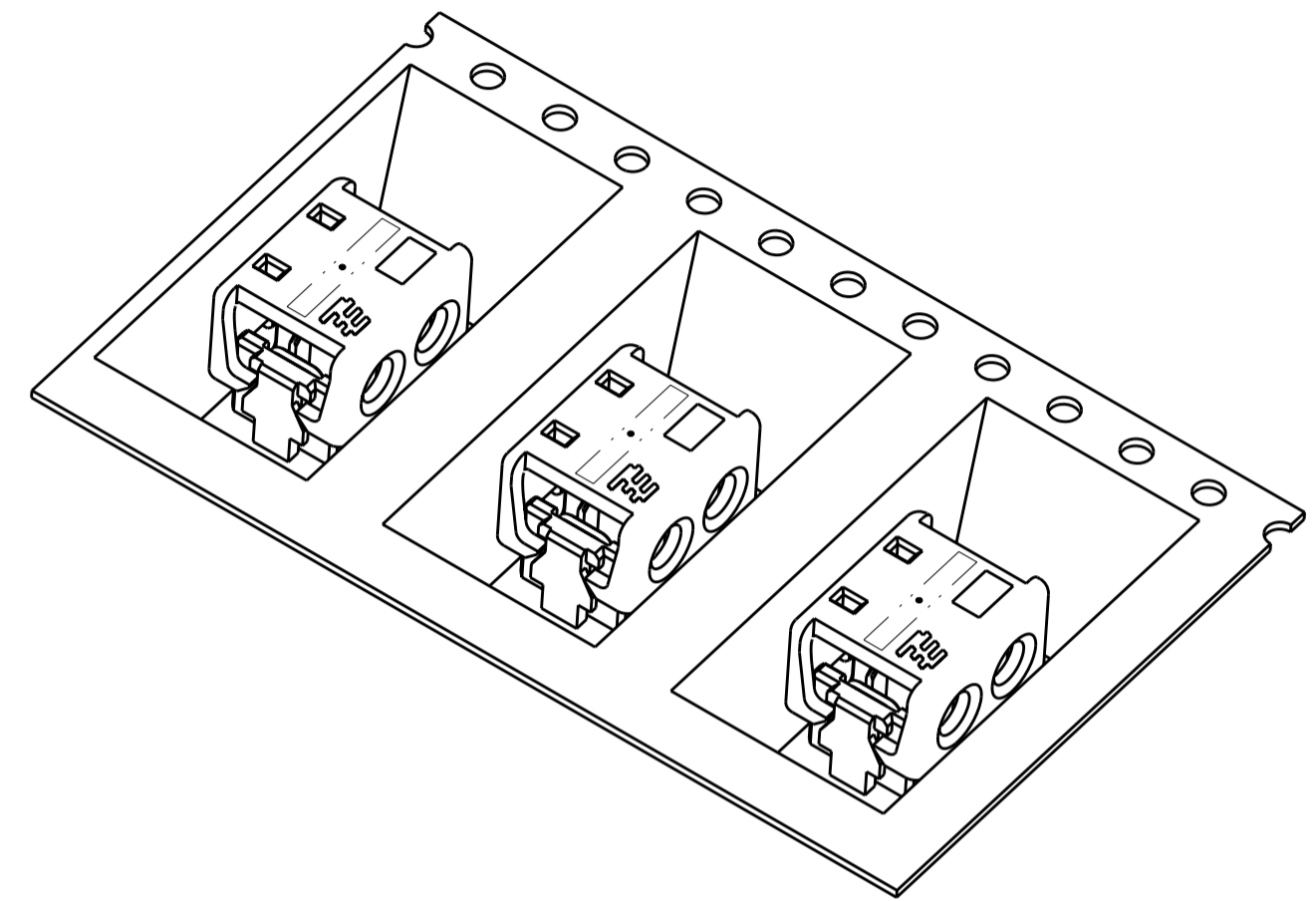
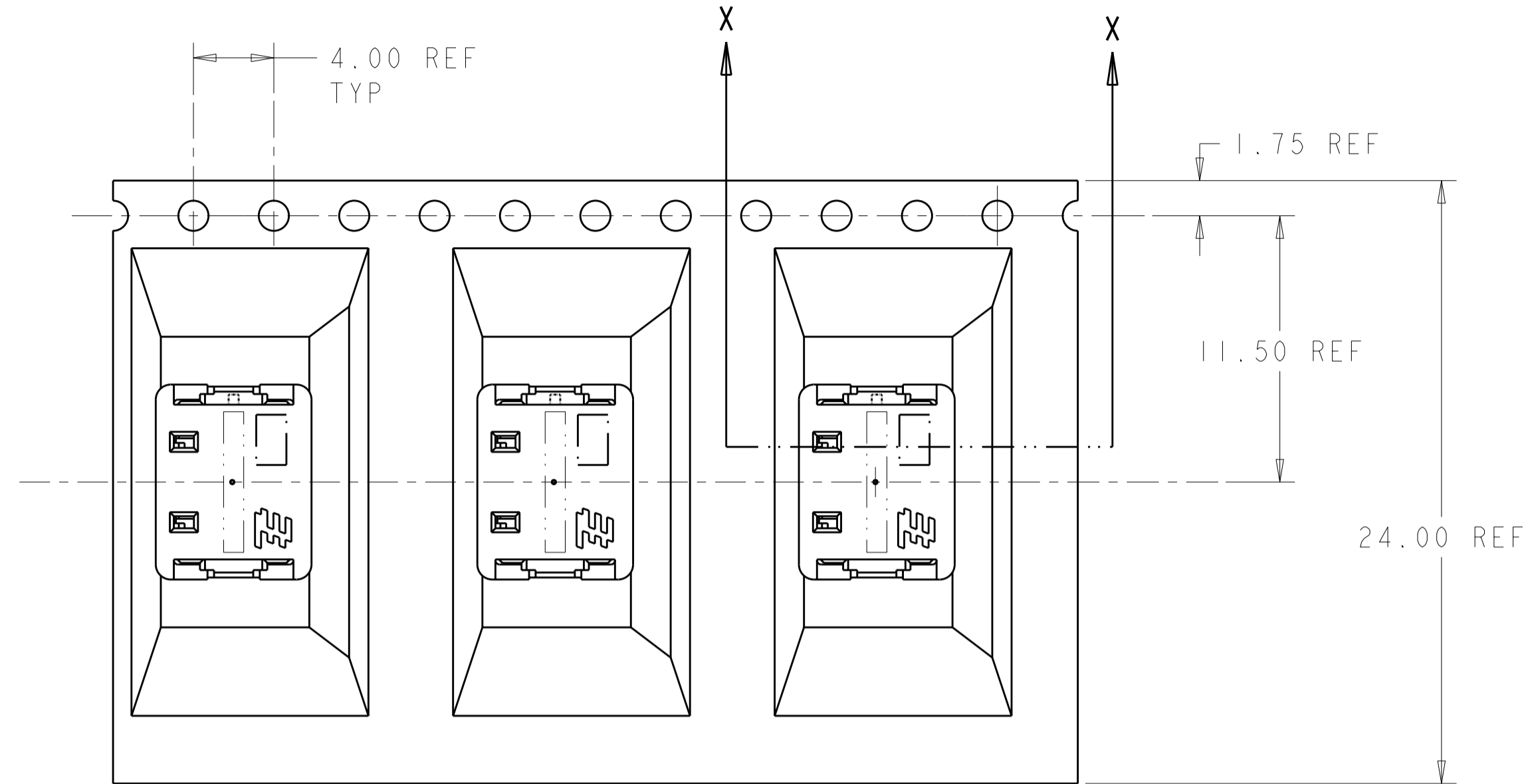

SECTION X-X

2106003-2 SHOWN IN POCKET TAPE

<small>THIS DRAWING IS A CONTROLLED DOCUMENT FOR TYCO ELECTRONICS CORPORATION. IT IS SUBJECT TO CHANGE AND THE CONTROLLING ENGINEERING ORGANIZATION SHOULD BE CONTACTED FOR THE LATEST REVISION.</small>		DWN C. DAILY 09DEC2008 CHK J. DYER 09DEC2008 APVD -	Tyco Electronics Tyco Electronics Harrisburg, PA 17105-3608
DIMENSIONS: mm 	TOLERANCES UNLESS OTHERWISE SPECIFIED: 0 PLC ± 1 PLC ±0.5 2 PLC ±0.13 3 PLC ± 4 PLC ± ANGLES ± FINISH ±	PRODUCT SPEC 108-2404 APPLICATION SPEC 114-13266 WEIGHT -	NAME ASSEMBLY, IDC SSL CONNECTOR, SMT, CLOSED END SIZE CAGE CODE DRAWING NO RESTRICTED TO A200779 C-2106003 -
MATERIAL		CUSTOMER DRAWING	SCALE 4:1 SHEET 4 OF 4 REV A